

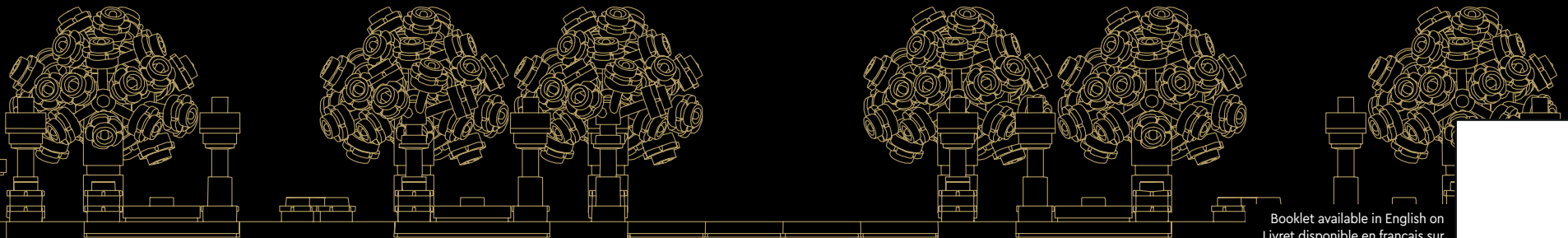

Eiffel tower

Book 1 · Livre 1 · Libro 1



Booklet available in English on
Livret disponible en français sur
Folleto disponible en español en

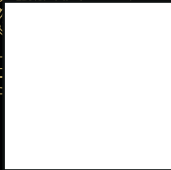



We're making our packaging more sustainable

We're transitioning from single-use plastic to paper-based packaging. As we progress, you may find a mix of paper and plastic in our boxes.

Nous rendons nos emballages plus durables

Nous passons des emballages en plastique à usage unique aux emballages à base de papier. Durant la transition, vous pourriez trouver un mélange de papier et de plastique dans nos boîtes.

Queremos hacer más sustentables nuestros materiales de embalaje

Estamos cambiando las bolsas de plástico desechables por bolsas con base de papel. Conforme avanzamos en este propósito, puedes encontrar una mezcla de papel y de plástico en nuestras cajas.

[LEGO.com/sustainable-packaging](https://www.lego.com/sustainable-packaging)

Eiffel tower

The Eiffel tower (La tour Eiffel) is the striking, iron lattice structure located on the Champ de Mars in the French capital. It's named after the engineer, Gustave Eiffel, whose company designed and built the tower as the impressive entrance to the 1889 Exposition Universelle, or World's Fair. Rising 1,063 ft. (324 m) into the air, it's one of the most recognizable structures in the world and an iconic symbol of both the city of Paris and France.

La tour Eiffel

La tour Eiffel est une impressionnante structure en treillis métallique située sur le Champ-de-Mars, dans la capitale française. Elle doit son nom à l'ingénieur Gustave Eiffel, dont l'entreprise a conçu et construit la tour comme entrée imposante de l'Exposition universelle de 1889. S'élevant à 324 m, la tour est l'une des plus célèbres structures du monde et représente un symbole emblématique de la ville de Paris et de la France.

Torre Eiffel

La torre Eiffel (en francés, *la tour Eiffel*) es la impresionante estructura de hierro ubicada en el Campo de Marte de la capital francesa. Su nombre rinde homenaje al ingeniero Gustave Eiffel, cuya empresa diseñó y construyó la torre como una espectacular puerta de acceso a la Exposition Universelle (Exposición Universal) de 1889. Con 324 m de altura, se trata de una de las estructuras más conocidas del mundo y se ha convertido en un símbolo tanto de París como de Francia.



The original idea

When it was decided to mark the 100-year anniversary of the French Revolution with a World Fair, an official competition was launched to find a suitable centerpiece for the exhibition. From the 107 different projects that were submitted, the committee selected Gustave Eiffel's vision for a 985-ft. (300 m) tall iron tower.

Two of his engineers, Maurice Koechlin and Emile Nouguier, already had an idea for a large pylon with four separated columns of latticework girders coming together at the top.

Company architect Stephen Sauvestre then proposed stonework pedestals to dress the legs and decorative arches to link the columns at the first level.

Gustave Eiffel hoped the structure would come to symbolize *"not only the art of the modern engineer, but also the century of Industry and Science in which we are living."*

L'idée originale

Lorsqu'il a été décidé de marquer le centenaire de la Révolution française par une exposition universelle, un concours officiel a été lancé pour trouver une pièce maîtresse convenable pour l'exposition. Parmi les 107 projets présentés, le comité a sélectionné le projet de Gustave Eiffel, à savoir une tour en fer de 300 m de haut.

Deux de ses ingénieurs, Maurice Koechlin et Émile Nouguier, imaginaient déjà un grand pylône avec quatre colonnes séparées de poutres en treillis se rejoignant au sommet.

L'architecte de l'entreprise, Stephen Sauvestre, proposa des piliers en maçonnerie pour habiller les jambes et des arches décoratives pour relier les colonnes au premier niveau.

Gustave Eiffel souhaitait que la structure devienne le symbole *« non seulement de l'art de l'ingénieur moderne, mais aussi du siècle de l'industrie et de la science dans lequel nous vivons »*.

La idea original

A raíz de la decisión de conmemorar el 100 aniversario de la Revolución francesa con una feria mundial, se organizó un concurso con el fin de encontrar el elemento central apropiado para la muestra. De los 107 proyectos enviados, el comité seleccionó el plan presentado por Gustave Eiffel, que consistía en crear una torre de hierro de 300 m de altura.

Dos de sus ingenieros, Maurice Koechlin y Émile Nouguier, habían concebido un diseño basado en un gran pórtico con cuatro columnas de vigas entrelazadas unidas por el

extremo superior. Stephen Sauvestre, arquitecto de la empresa, propuso pedestales de mampostería para cubrir las patas y unir las columnas del primer nivel con arcos decorativos.

Gustave Eiffel esperaba que la estructura llegara a simbolizar *"no solo la capacidad artística del ingeniero moderno, sino también el siglo de progreso industrial y científico en el que vivimos"*.

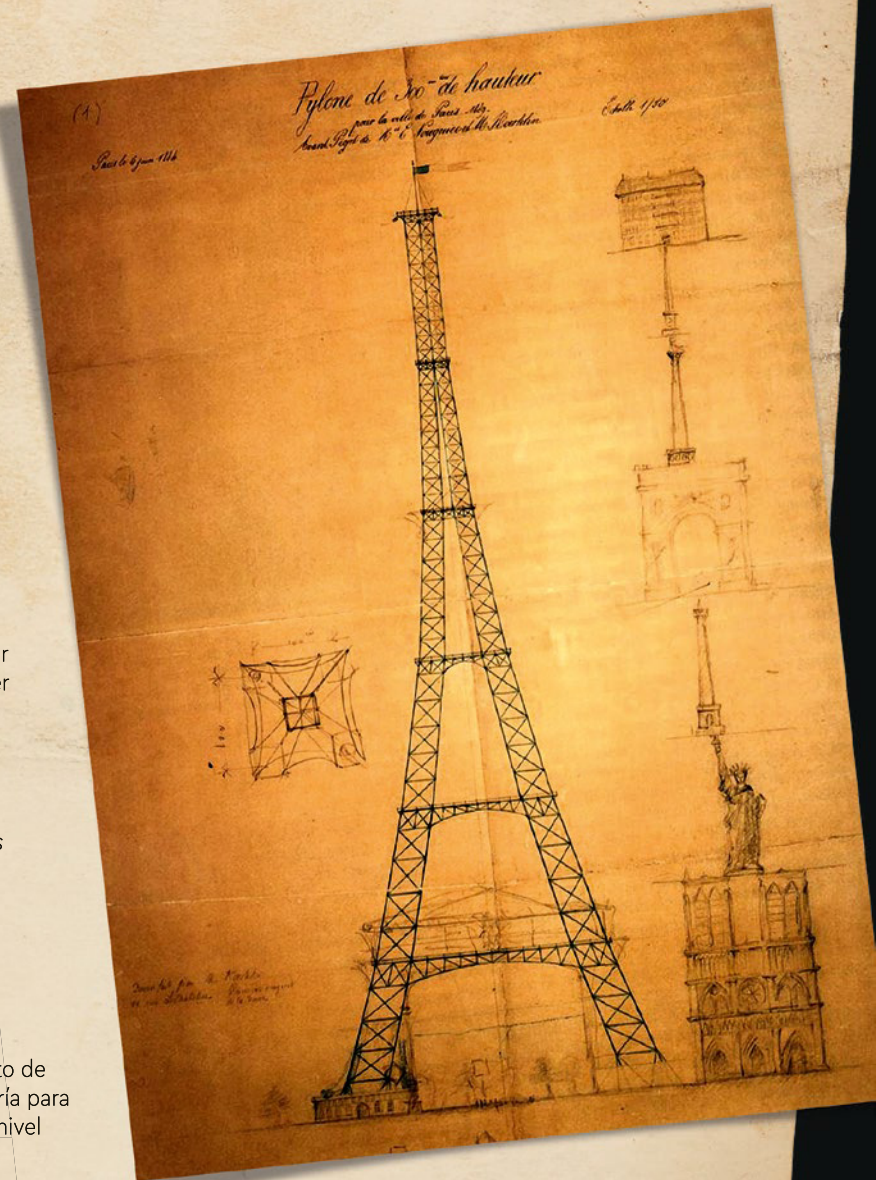

An early sketch of the tower from circa 1884.

Une esquisse préliminaire de la tour datant de 1884 environ.

Uno de los primeros bocetos de la torre, de alrededor de 1884.

“I ought to be jealous of the tower. She is more famous than I am.”

GUSTAVE EIFFEL

Gustave Eiffel **(1832 – 1923)**

Born on December 15, 1832, in Dijon, France, Gustave Eiffel was an exceptionally gifted engineer and builder. He graduated from the École Centrale des Arts et Manufactures in 1855 and established his own construction company in 1864.

He made his name creating a large and varied number of metal structures, including everything from railway bridges and viaducts to the internal framework for the Statue of Liberty. He and his company were known for their ingenuity and inventiveness, which culminated with the construction of the Eiffel tower.

Gustave Eiffel **(1832 – 1923)**

Né le 15 décembre 1832 à Dijon, en France, Gustave Eiffel était un ingénieur et un constructeur exceptionnellement doué. Il est diplômé de l'École centrale des arts et manufactures en 1855 et crée sa propre entreprise de construction en 1864.

Il s'est fait un nom en créant un éventail vaste et varié de structures métalliques, allant des ponts et des viaducs ferroviaires à la charpente interne de la statue de la Liberté. Lui et son entreprise étaient connus pour leur ingéniosité et leur inventivité, qui ont culminé avec la construction de la tour Eiffel.

Gustave Eiffel **(1832-1923)**

Nacido el 15 de diciembre de 1832 en Dijon (Francia), Gustave Eiffel fue un genial ingeniero y constructor. Se graduó en la École Centrale des Arts et Manufactures en 1855 y estableció su propia empresa de construcción en 1864.

Se hizo de una reputación creando una gran cantidad de estructuras metálicas para los usos más diversos, desde puentes y viaductos ferroviarios hasta la armazón interna de la Estatua de la Libertad. Él y su empresa eran reconocidos por su ingenio e inventiva, lo que culminó con la construcción de la torre Eiffel.

**« Je devrais être jaloux de la tour.
Elle est plus célèbre que moi. »**

GUSTAVE EIFFEL

**“Debería sentir celos de la torre.
Es más famosa que yo”.**

GUSTAVE EIFFEL



Under construction

Gustave Eiffel's company produced over five thousand drawings in preparation for joining the 18,038 individual pieces together to form the tower. Work on the foundations started in January 1887 and the assembly of the tower began on July 1 of that year.

All the elements were prepared in Eiffel's factory located at Levallois-Perret on the outskirts of Paris. The pieces were hauled up by steam cranes, which themselves climbed up the tower as the construction continued.

En construction

L'entreprise de Gustave Eiffel a réalisé plus de cinq mille dessins en vue de l'assemblage des 18 038 pièces individuelles qui forment la tour. La construction des fondations a commencé en janvier 1887 et le montage de la tour a débuté le 1er juillet de la même année.

Tous les éléments furent préparés dans l'usine d'Eiffel située à Levallois-Perret, dans la banlieue de Paris. Les pièces étaient hissées par des grues à vapeur, qui elles-mêmes gravissaient la tour au fur et à mesure de la construction.

En construcción

Como parte de los preparativos para unir las 18.038 piezas que conforman la torre, la empresa de Gustave Eiffel produjo más de cinco mil dibujos. El trabajo en los cimientos comenzó en enero de 1887 y la estructura empezó a ensamblarse el 1 de julio de ese año.

Todos los elementos se prepararon en la fábrica de Eiffel, ubicada en Levallois-Perret, a las afueras de París. Las piezas se subían utilizando grúas de vapor que tenían la capacidad de ascender por la torre una vez que la construcción avanzaba lo suficiente.

After two years, two months and five days the structure was completed and in March 1889, Eiffel led a group of government officials and the press to the top of the tallest structure in the world. Since the elevators were not yet in operation, the ascent was made by foot and took over an hour. Here Eiffel unfurled a large Tricolore to the accompaniment of a 25-gun salute.

Après deux ans, deux mois et cinq jours, la structure est achevée et en mars 1889, Eiffel emmène un groupe de membres du gouvernement, accompagnés de journalistes, au sommet de la plus haute structure du monde. Les ascenseurs ne fonctionnaient pas encore, et l'ascension à pied dura plus d'une heure. Eiffel déploya au sommet un grand drapeau tricolore, au son de 25 coups de fusil.

La edificación se completó luego de dos años, dos meses y cinco días, y, en marzo de 1889, Eiffel condujo a un grupo de funcionarios del Gobierno e integrantes de la prensa a la parte superior de la estructura más alta del mundo. Dado que los elevadores aún no funcionaban, tuvieron que subir a pie, lo cual les llevó más de una hora. Una vez arriba, Eiffel desplegó una gigantesca bandera de Francia al tiempo que 25 cañones ejecutaban una salva.

Gustave Eiffel constructed and reserved a small apartment for himself at the top of the tower to entertain guests. It's now open to the public, complete with period decorations and lifelike mannequins of Eiffel and some of his notable guests.

Gustave Eiffel construit et se réserve un petit appartement au sommet de la tour pour recevoir des invités. Il est désormais ouvert au public et présente des décorations d'époque et des mannequins réalistes d'Eiffel et de certains de ses invités célèbres.

Gustave Eiffel construyó un pequeño departamento en la parte superior de la torre y lo reservó para sí y para albergar a sus invitados. Hoy en día se encuentra abierto al público, decorado con artículos de aquella época y maniqués a tamaño natural de Eiffel y algunos de sus visitantes más notables.

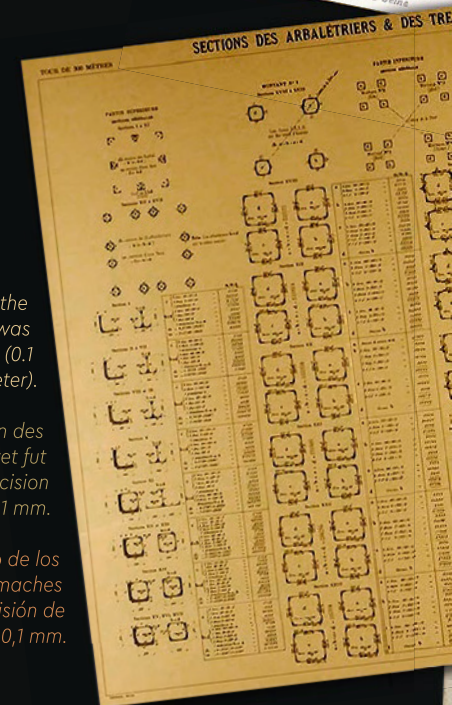

The position of each of the 2,500,000 rivet holes was specified to within 0.04 inch (0.1 millimeter).

La posición de chacun des 2 500 000 trous de rivet fut spécifiée avec une précision de 0,1 mm.

La posición de cada uno de los 2.500.000 orificios de los remaches se especificó con una precisión de 0,1 mm.

de Monsieur Eiffel
horizontale co
n° 0008 p. m.



ILLIS - DONNÉES POUR LE CALCUL DE L'OSSATURE

Technical drawing page with tables and diagrams. Includes a vertical elevation of the tower and various data tables.

TABLEAU DES HAUTEURS	
Hauteur	Distance
100	100
200	200
300	300
400	400
500	500
600	600
700	700
800	800
900	900
1000	1000

TABLEAU DES DISTANCES

Distance	Hauteur
100	100
200	200
300	300
400	400
500	500
600	600
700	700
800	800
900	900
1000	1000



December 7, 1887
7 décembre 1887
7 de diciembre de 1887



March 20, 1888
20 mars 1888
20 de marzo de 1888

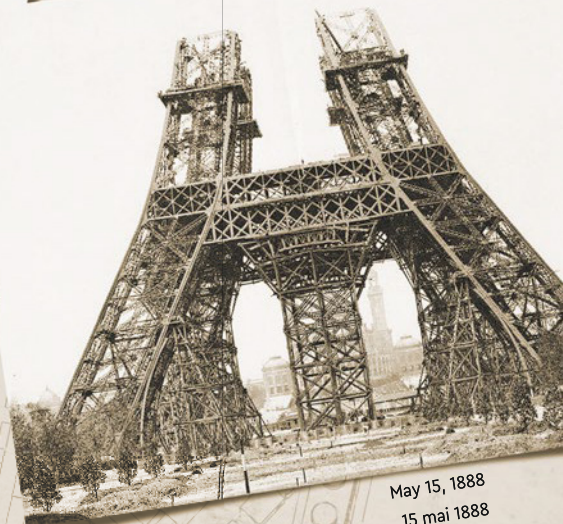

May 15, 1888
15 mai 1888
15 de mayo de 1888



August 21, 1888
21 août 1888
21 de agosto de 1888

December 26, 1888
26 décembre 1888
26 de diciembre de 1888

March 15, 1889
15 mars 1889
15 de marzo de 1889



The tower as a gateway to the World's Fair.

La tour comme entrée de l'Exposition universelle.

La torre como puerta de acceso a la Exposición Universal.

Exposition Universelle 1889

The 1889 World's Fair contained over 61,000 individual exhibitors, 25,000 of whom were from outside France, and covered subjects such as science, technology, industrial engineering and fine arts. The Exposition stretched over two large sites in the city and attracted 32 million visitors in the six months it ran. The Eiffel tower itself proved an

immediate success with the public and lengthy queues formed to make the ascent. Tickets cost two francs for the first level, three for the second and five for the top, with half-price admission on Sundays. By the end of the Fair in October 1889, the tower alone had had nearly two million visitors.

Exposition universelle 1889

L'Exposition universelle de 1889 comptait plus de 61 000 exposants individuels, dont 25 000 venus de l'étranger, et abordait des sujets tels que la science, la technologie, le génie industriel et les beaux-arts. L'Exposition couvrait deux grands sites de la ville et a attiré 32 millions de visiteurs pendant ses six mois d'existence. La tour remporta un succès

immédiat auprès du public et de longues files d'attente se formèrent pour effectuer l'ascension. Les billets coûtaient deux francs pour le premier étage, trois pour le deuxième et cinq pour le sommet, avec un billet à moitié prix le dimanche. À la fin de l'Exposition, en octobre 1889, la tour avait accueilli à elle seule près de deux millions de visiteurs.

Exposition Universelle de 1889

Esta feria mundial celebrada en 1889 contó con la participación de 61.000 expositores individuales, 25.000 provenientes de fuera de Francia, y contempló temas como ciencia, tecnología, ingeniería industrial y bellas artes. La exposición ocupó dos grandes sedes en la ciudad y atrajo a 32 millones de visitantes a lo largo de los seis meses que duró. La torre Eiffel misma fue un éxito inmediato

entre el público y no tardaron en formarse inmensas colas para realizar el ascenso. Las entradas costaban dos francos para el primer nivel, tres para el segundo y cinco para la cúspide, y podían adquirirse a mitad de precio los domingos. Para cuando concluyó la feria en octubre de 1889, la torre había sido visitada por casi dos millones de personas.





The tallest structure in the world

Builders, architects and engineers have always had a desire to reach for the stars and create tall buildings. As tools and technologies improved through time, so did the scale and magnitude of these efforts. The Eiffel tower was the first structure in the world to surpass both the 656-ft. (200-meter) and 984-ft. (300-meter) mark in height and became the tallest man-made structure when it was completed in 1889. It would remain so until 1930 when the 1,046-ft. (319-m) tall Chrysler Building in New York, USA, opened.

La plus haute structure du monde

Les constructeurs, les architectes et les ingénieurs ont toujours eu le désir de se hisser vers les étoiles et de créer de grands bâtiments. Les outils et les technologies se sont améliorés au fil du temps, tout comme l'échelle et l'ampleur de ces efforts. La tour Eiffel a été la première structure au monde à dépasser à la fois la barre des 200 mètres et celle des 300 mètres, devenant ainsi la plus haute structure construite par l'homme lors de son achèvement en 1889. Elle le resta jusqu'en 1930, année de l'inauguration du Chrysler Building de 319 mètres de haut à New York, aux États-Unis.

La estructura más alta del mundo

Los constructores, arquitectos e ingenieros son personas de grandes miras que siempre han soñado con construir edificios más y más altos. El paso del tiempo nos ha dado herramientas y tecnologías cada vez mejores, lo que impulsa la magnitud de sus esfuerzos. La torre Eiffel fue la primera edificación del mundo en superar las marcas de 200 y 300 m de altura y, cuando se completó en 1889, se convirtió en la estructura más alta hecha por el hombre. Así sería hasta 1930, cuando el Edificio Chrysler, que se alza 319 m sobre el suelo de Nueva York (EE. UU.), abrió sus puertas.

From then until now

Eiffel had a permit for the tower to stand for twenty years after which it was to be dismantled. He successfully argued the structure was valuable for communication and scientific purposes and the tower was allowed to stand. A meteorology lab and a small wind tunnel were installed and over 5,000 scientific tests were carried out. With the advent of wireless telegraphy, the top of the tower would be modified to accommodate an ever-growing number of antennas, plus a television mast that extended the height of the tower to 1,063 ft. (324 meters).

Today the Eiffel tower also welcomes more visitors than any other paid monument in the world – an estimated seven million people per year. Some five hundred employees are responsible for its daily operation, ensuring that eager crowds enjoy panoramic views of the city.

De ce jour à aujourd'hui

Eiffel avait obtenu l'autorisation de laisser la tour érigée pendant vingt ans, après quoi elle devait être démantelée. Il a réussi à faire valoir que la structure était précieuse tant pour la communication que pour des raisons scientifiques, et la tour a pu rester en place. Un laboratoire de météorologie et une petite soufflerie ont été installés, et plus de 5 000 tests scientifiques y ont été réalisés. Avec l'avènement de la télégraphie sans fil, le sommet de la tour est modifié pour accueillir un nombre toujours plus grand d'antennes, ainsi qu'un mât de télévision qui porte la hauteur de la tour à 324 mètres.

Aujourd'hui, la tour Eiffel accueille plus de visiteurs que tout autre monument payant au monde, environ sept millions de personnes par an. Cinq cents employés assurent son fonctionnement quotidien, permettant à des foules enthousiastes d'admirer des vues panoramiques sur la ville.

Desde entonces hasta hoy

Eiffel obtuvo permiso para que la torre permaneciera en pie durante veinte años, plazo después del cual debía ser desmantelada. Su defensa de que la estructura resultaba valiosa para fines científicos y de comunicaciones tuvo éxito, y la torre pudo quedarse en pie. Se instalaron un laboratorio de meteorología y un pequeño túnel de viento, y se efectuaron más de 5000 pruebas científicas. Con la llegada de la telegrafía inalámbrica, la parte superior de la torre sería modificada para alojar un número siempre creciente de antenas, además de un mástil de televisión que aumentó su altura a 324 m.

En la actualidad, la torre Eiffel también da la bienvenida a más visitantes que cualquier otro monumento de pago del mundo (se estima un total de siete millones de personas por año). Unos quinientos empleados gestionan el día a día de la torre, asegurándose de que las impacientes multitudes puedan disfrutar de las vistas panorámicas de la ciudad.





“Can one think that because we are engineers, beauty does not preoccupy us or that we do not try to build beautiful, as well as solid and long-lasting structures?”

GUSTAVE EIFFEL

« Parce que nous sommes des ingénieurs, croit-on donc que la beauté ne nous préoccupe pas dans nos constructions et qu'en même temps que nous faisons solide et durable, nous ne nous efforçons pas de faire élégant ? »

GUSTAVE EIFFEL

“¿Quién puede pensar que, solo porque seamos ingenieros, no nos preocupe la belleza o que no intentemos siempre construir estructuras tan bellas como sólidas y perdurables?”.

GUSTAVE EIFFEL



“I was lucky enough to have been on top of the Eiffel tower twice as a boy.”

ROK ZGALIN KOBE

From the Design Team

Senior LEGO® Designer, Rok Zgalin Kobe was part of the team that brought this LEGO version of the iconic Eiffel tower to life.

“My goal was to blend great LEGO execution with the design principles of the original tower. I tried to follow the structural principles of the real tower as closely as the LEGO System would allow. For example, the load-bearing trusses on the model are placed just like on the original. And just like the original structure, the critical stage of LEGO construction is joining the legs at the first level.

The biggest challenge of a set this size is to make it stable and buildable, and to translate the final model into the logical flow of a LEGO building instructions guide. To ensure it is easy enough to follow without mistakes, yet still challenging enough to be engaging throughout the building process.

I am humbled to play a part in translating one of the most recognizable structures in human history into a LEGO model. I've made smaller versions of the tower before, but this one – the tallest LEGO model to date – is very different scale-wise!”

« J’ai eu la chance d’être au sommet de la tour Eiffel deux fois quand j’étais petit. »

ROK ZGALIN KOBE

Un mot de l’équipe de conception

Le concepteur principal LEGO®, Rok Zgalin Kobe, faisait partie de l'équipe qui a donné vie à cette version LEGO de l'emblématique tour Eiffel.

« Mon objectif était de combiner une excellente réalisation LEGO avec les principes de conception de la tour originale. J'ai essayé de suivre les principes structurels de la vraie tour aussi fidèlement que le permettait le système LEGO. Par exemple, les fermes porteuses du modèle sont placées exactement comme sur l'originale. Et tout comme pour la structure originale, l'étape critique de la construction LEGO est de joindre les jambes au premier niveau.

Le plus grand défi à relever pour un ensemble de cette taille est de le rendre stable et montable, et de traduire le modèle final dans le flux logique d'un guide d'instructions de construction LEGO. Pour faire en sorte qu'il soit suffisamment facile à suivre sans faire d'erreurs, tout en étant suffisamment stimulant pour que le processus de construction soit intéressant.

Je suis honoré de jouer un rôle dans la conversion de l'une des structures les plus reconnaissables de l'histoire humaine en un modèle LEGO. J'ai déjà réalisé des versions plus petites de la tour, mais celle-ci (le plus haut modèle LEGO à ce jour) est très différente au niveau de l'échelle ! »

“Tuve la fortuna de estar en la cima de la torre Eiffel dos veces cuando era niño”.

ROK ZGALIN KOBE

Impresiones del equipo de diseño

Rok Žgalin Kobe, diseñador sénior de LEGO®, formó parte del equipo que dio vida a esta versión LEGO de la icónica torre Eiffel.

“Mi objetivo era combinar armoniosamente la fantástica manera de construir con LEGO y los principios de diseño de la torre original. Intenté seguir los principios estructurales del monumento de verdad tan de cerca como lo permitieran los elementos LEGO. Por ejemplo, los entramados de carga del modelo están colocados de la misma forma que en la original. Y al igual que en esta, la etapa crítica de la construcción con LEGO es cuando se unen las patas en el primer nivel.

Entre los desafíos más grandes que implica un set de esta magnitud están hacer que este sea estable y construible y traducir el modelo final al proceso lógico de una guía de instrucciones de construcción LEGO. Lo que buscamos es asegurarnos de que la secuencia de pasos sea fácil de seguir sin cometer errores y, al mismo tiempo, represente un desafío que mantenga el interés a lo largo de todo el proceso de construcción.

Es un honor para mí poder contribuir para traducir una de las estructuras más conocidas de la historia de la humanidad en un modelo LEGO. Antes había construido otros modelos de la torre, más pequeños. Pero, en cuanto a escala, este es en verdad muy diferente, ¡es el modelo LEGO más alto que se haya hecho!”.



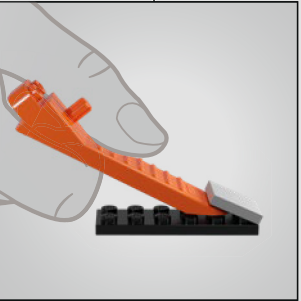
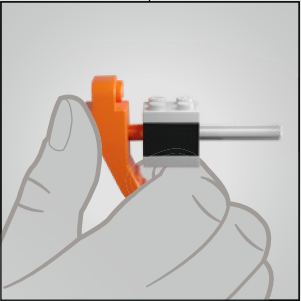
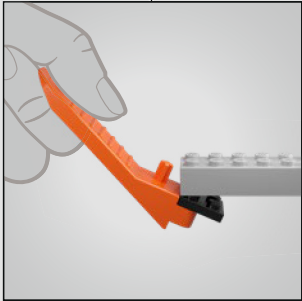
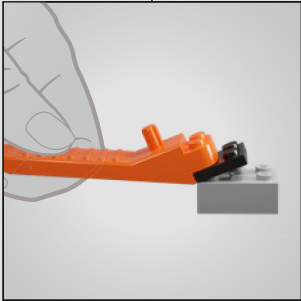
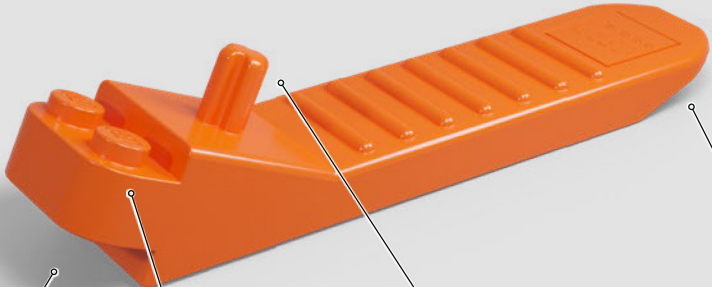

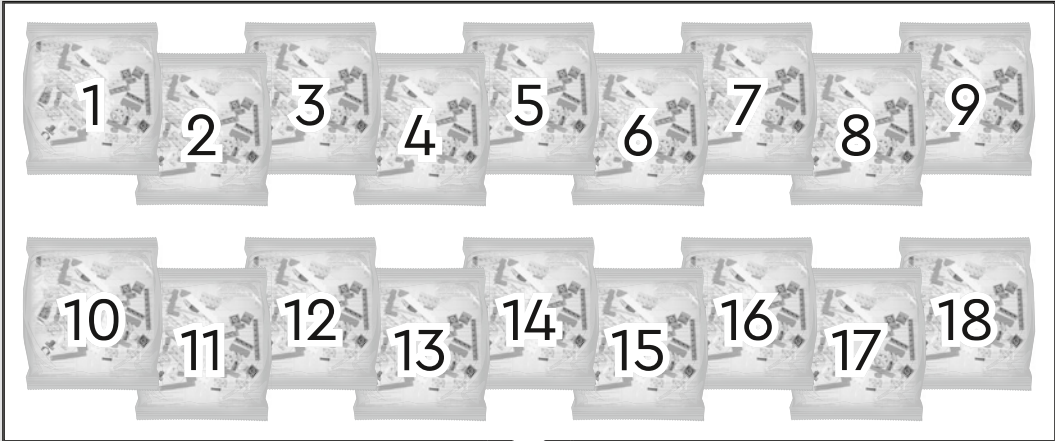

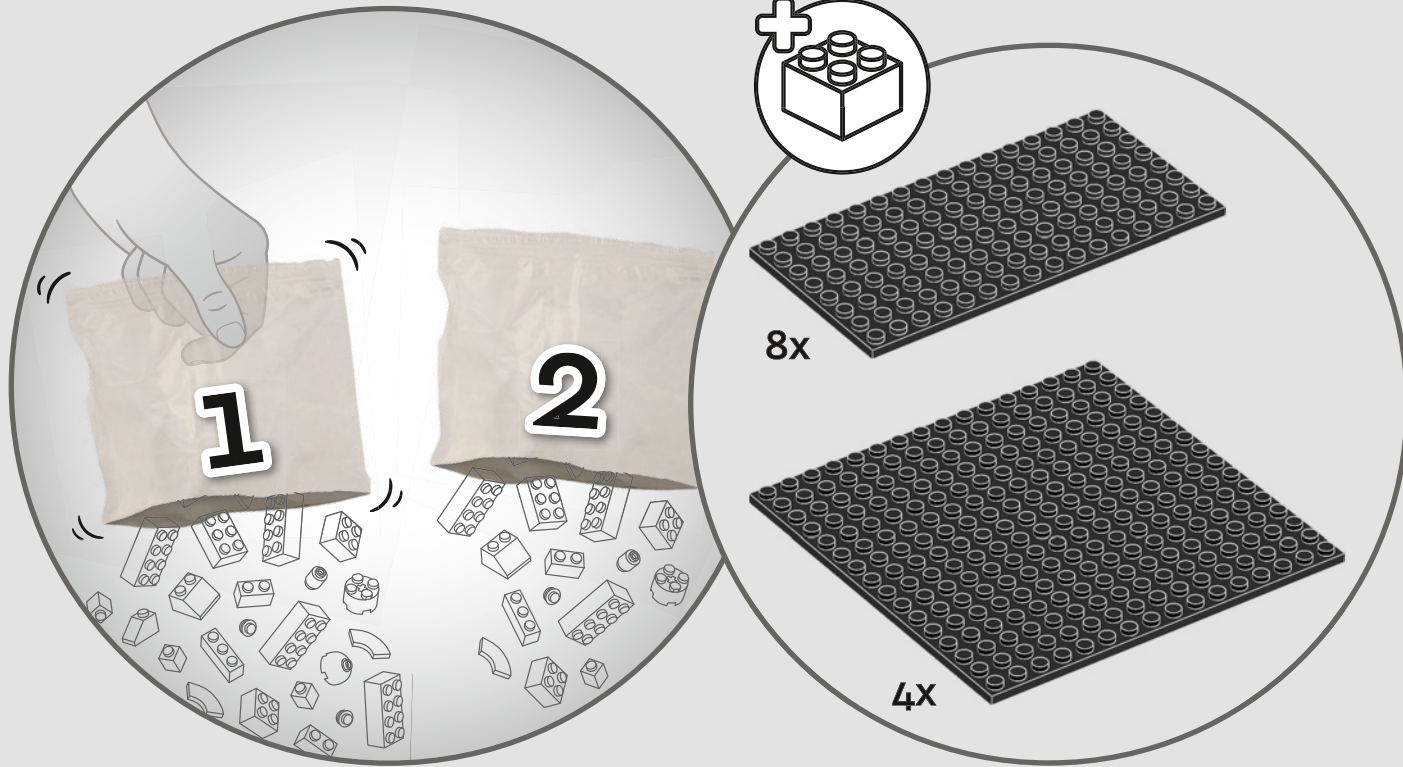



The Eiffel tower cost almost 8 million gold francs, or \$1.5 million US to build.

La construction de la tour Eiffel a coûté près de 8 millions de francs-or, soit 1,5 million de dollars américains.

Construir la Torre Eiffel costó casi 8 millones de francos oro (unos 1,5 millones de dólares estadounidenses).

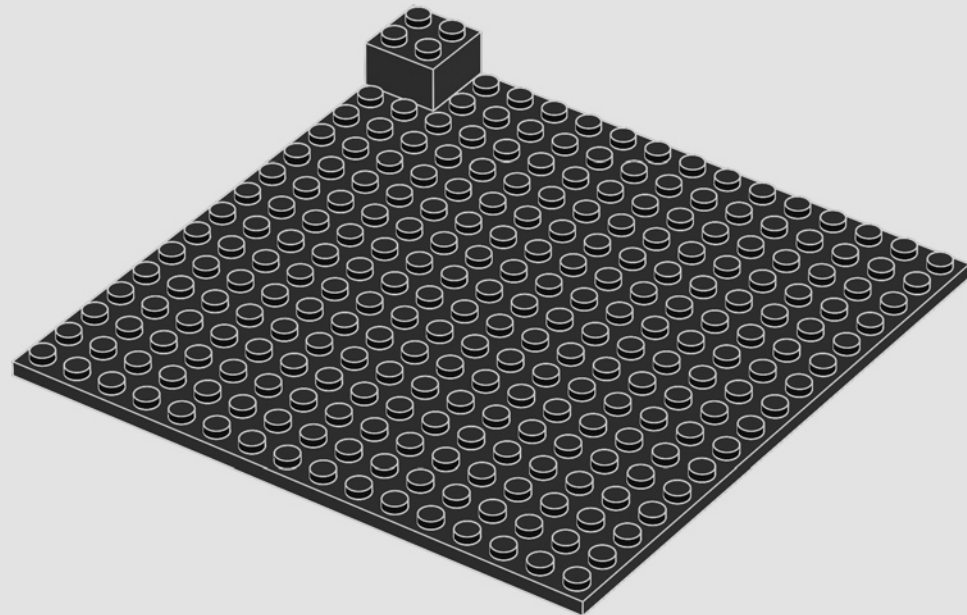
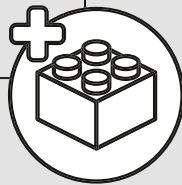
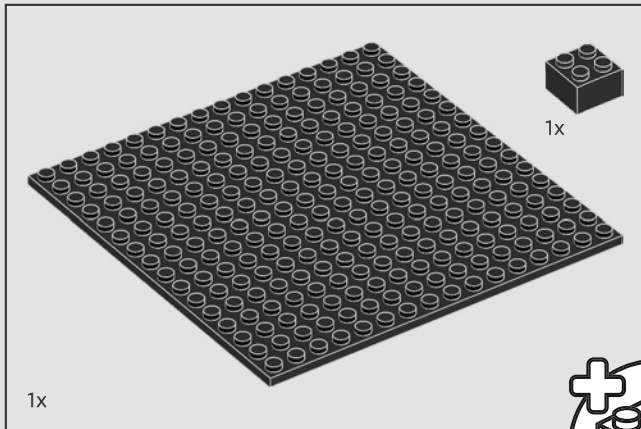
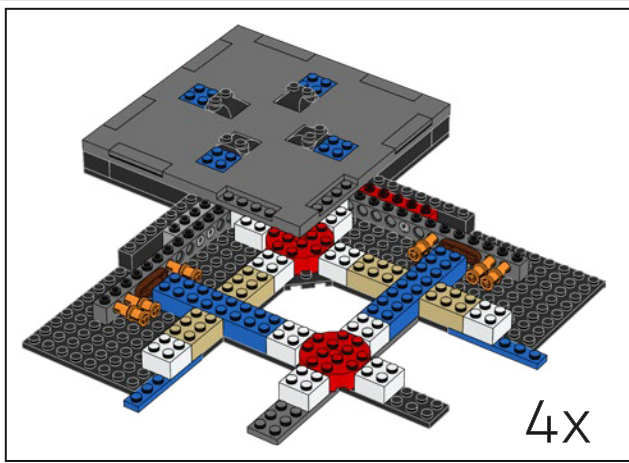

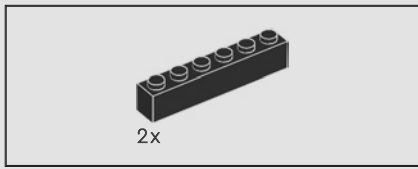

2

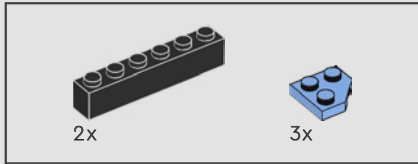
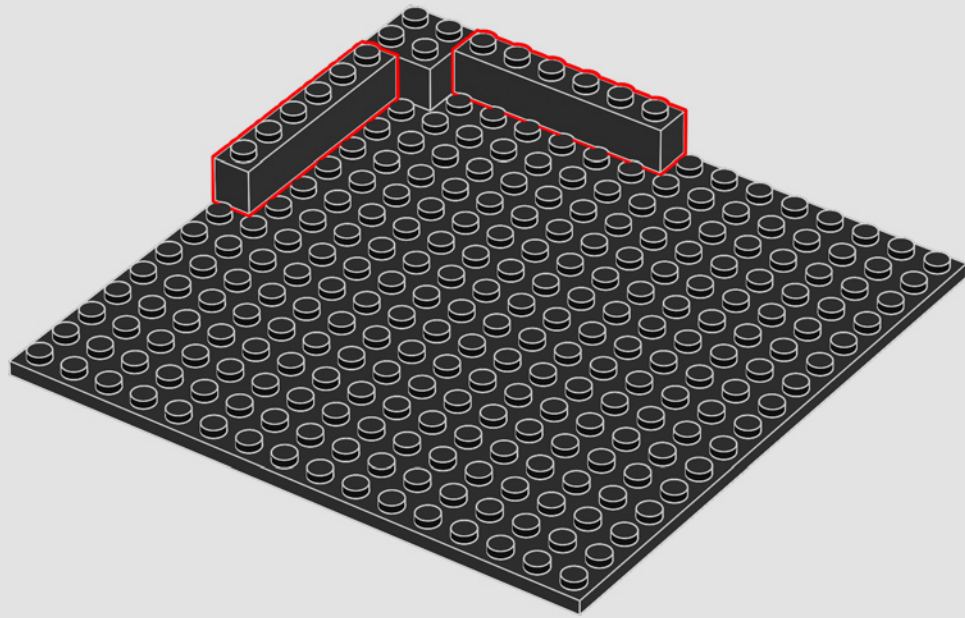

3

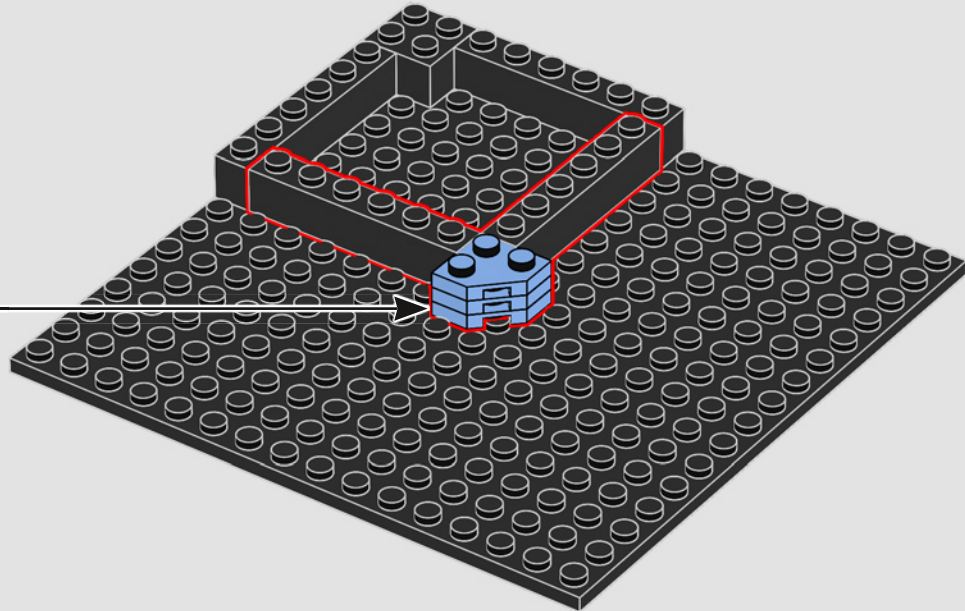
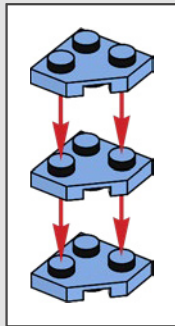

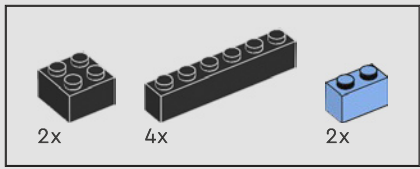

4

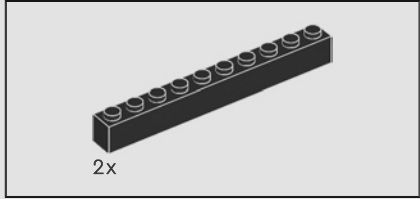
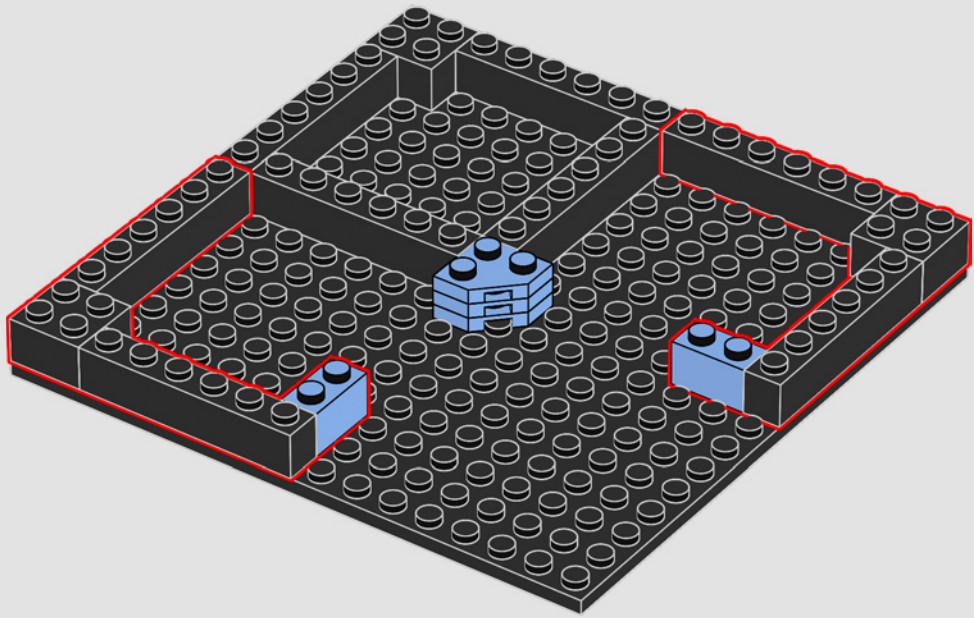

5

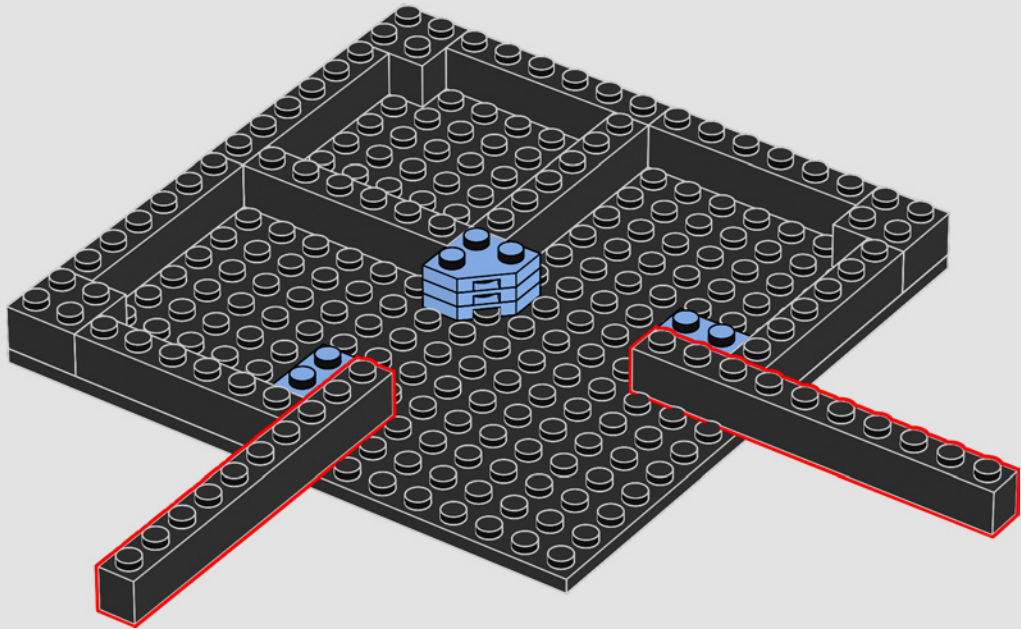

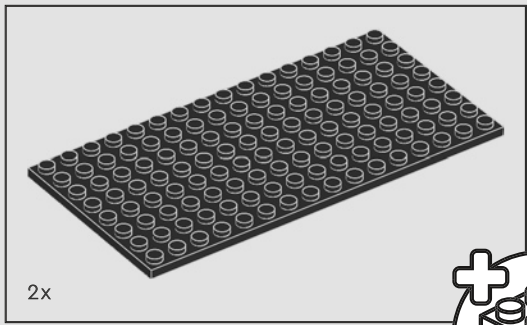

2x

6

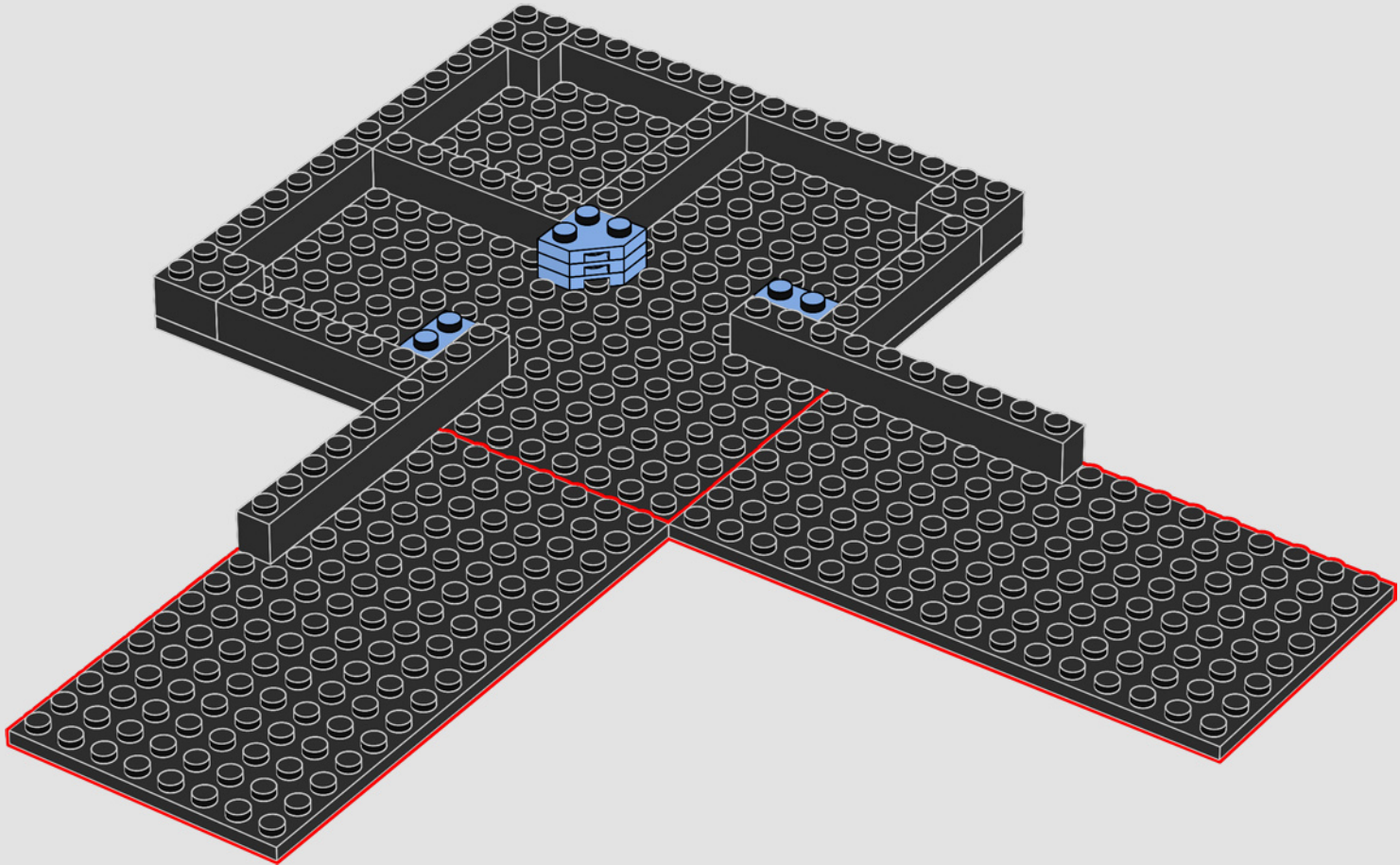
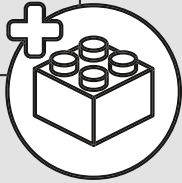

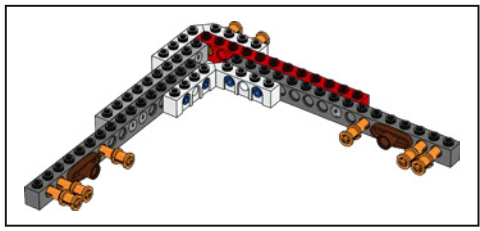

1

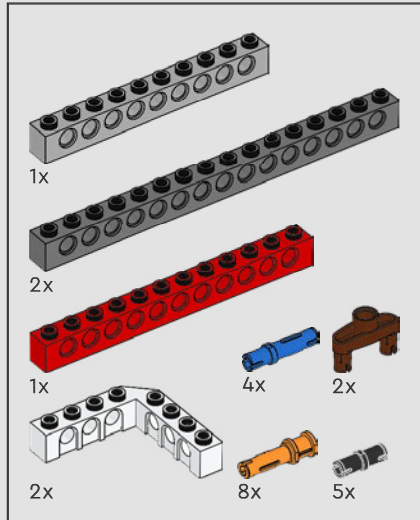
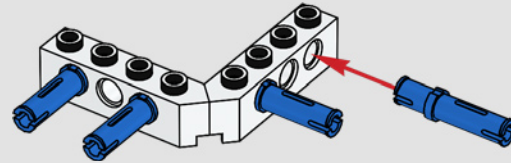

7

2

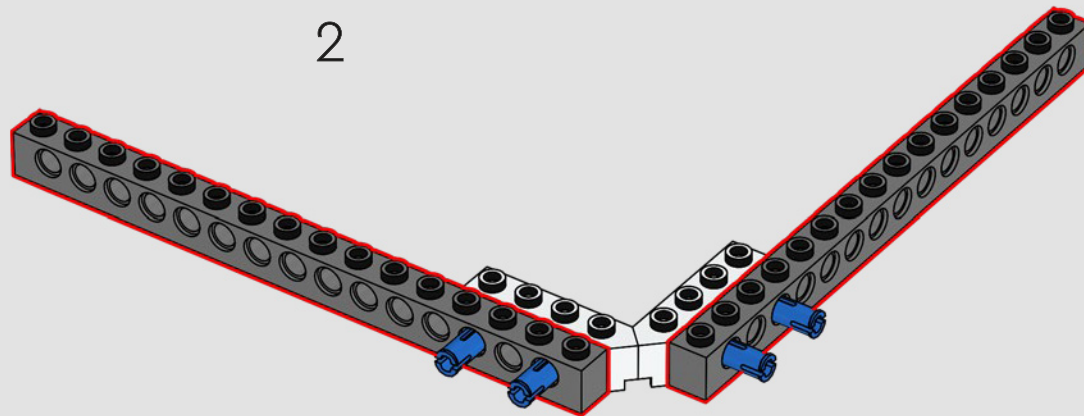

3

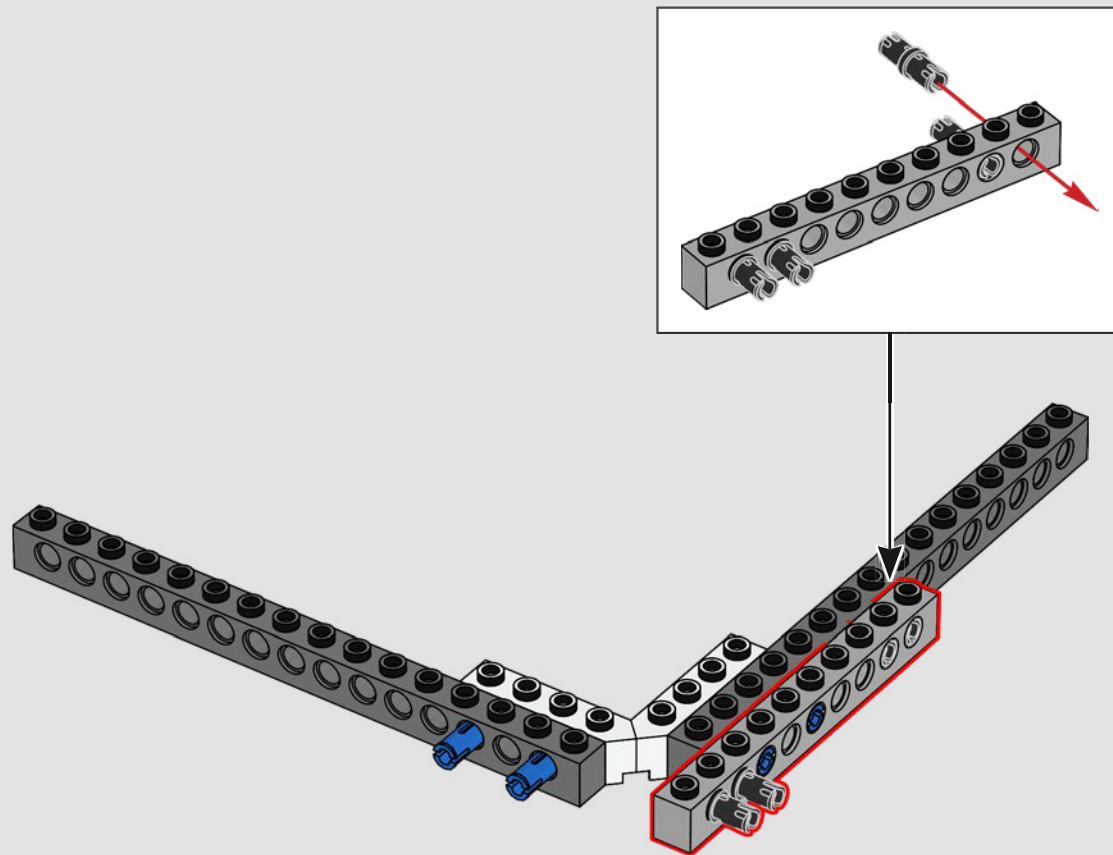

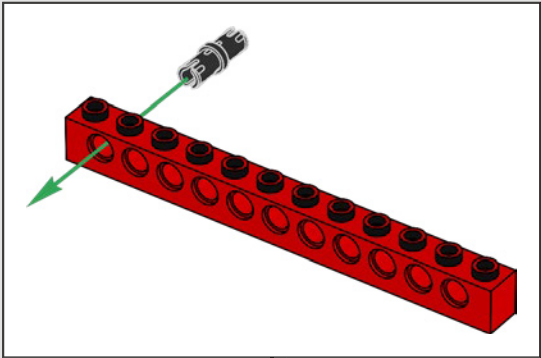

4

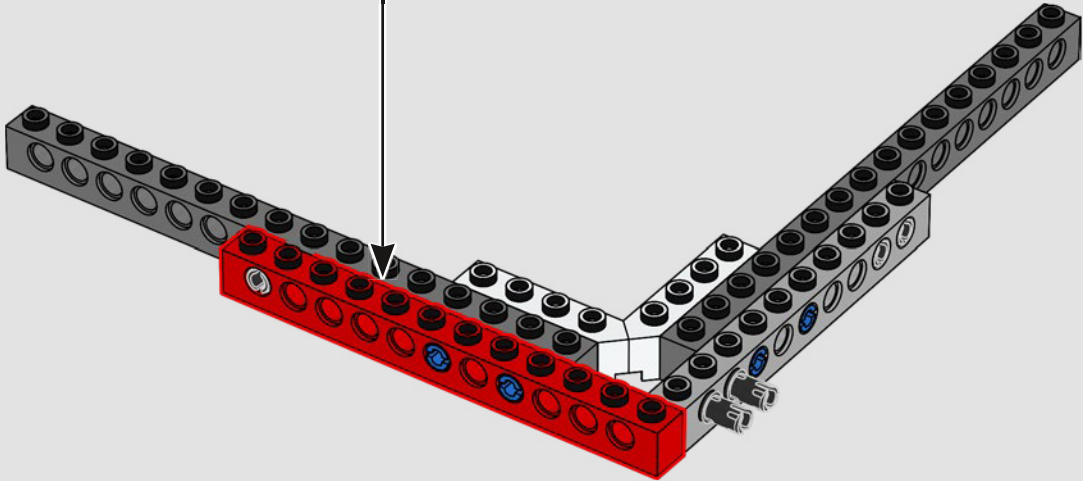

5

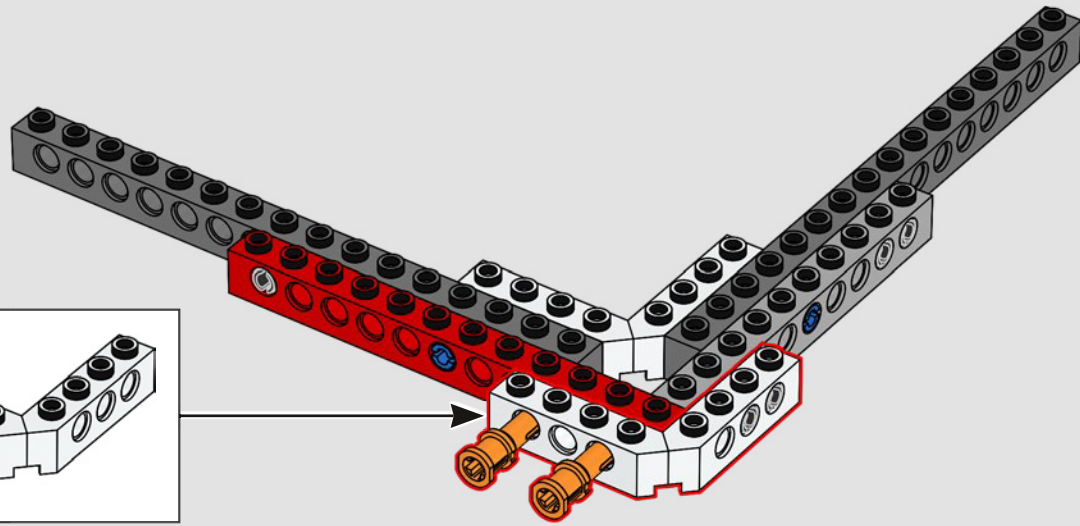
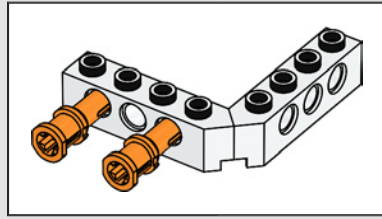

6

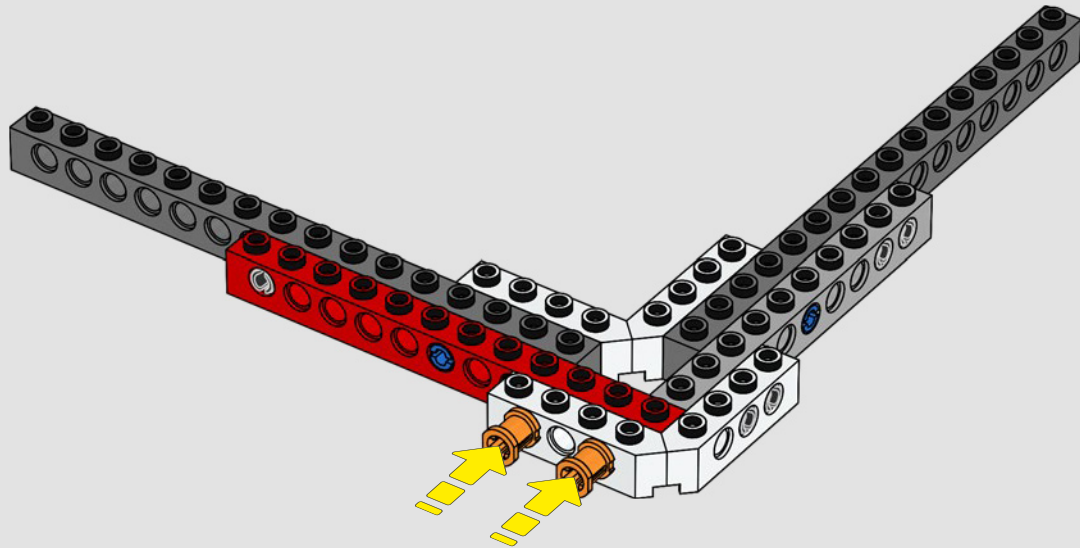



7

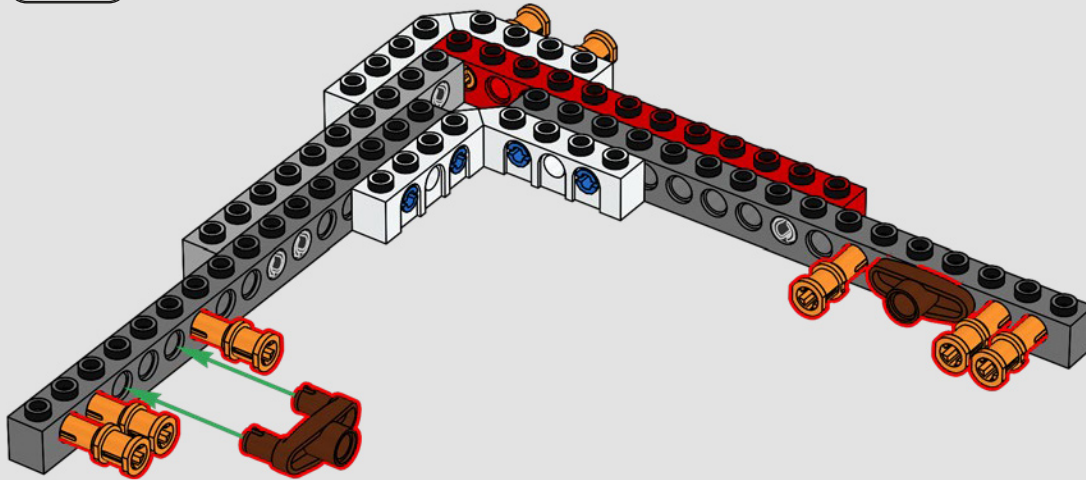

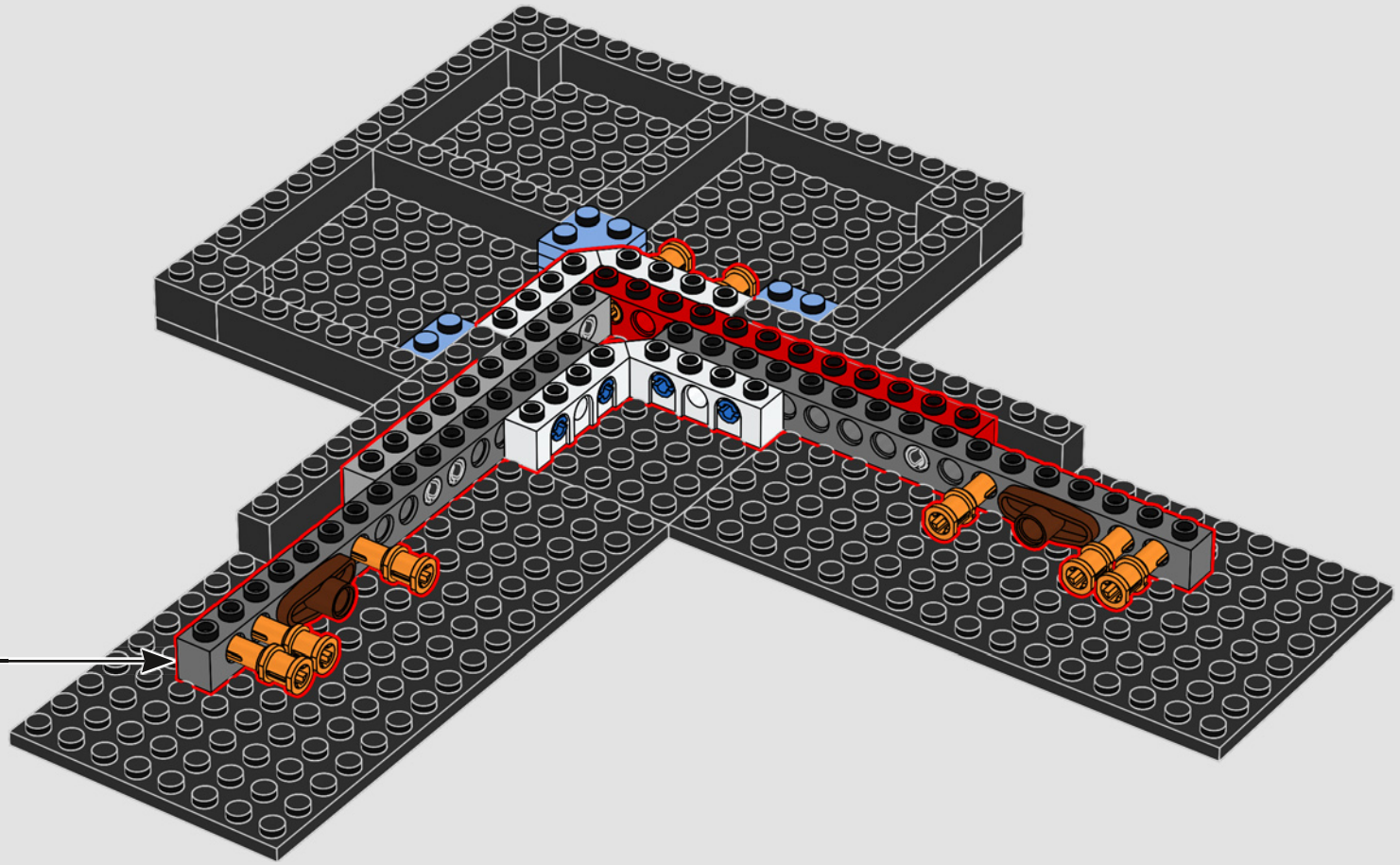



2x

8

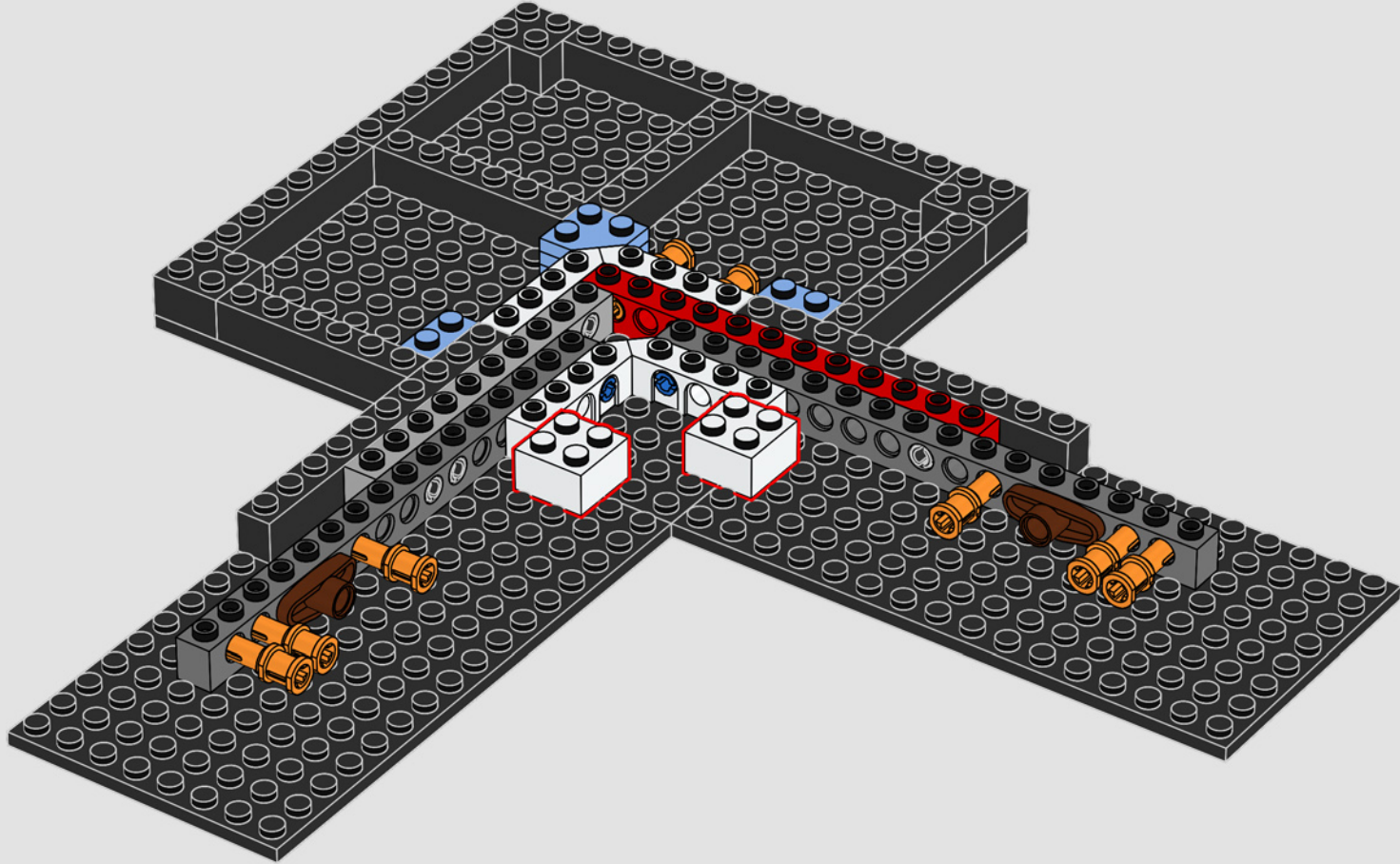

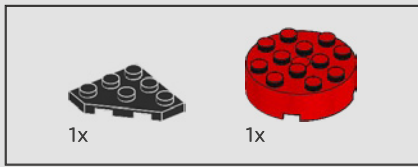

9

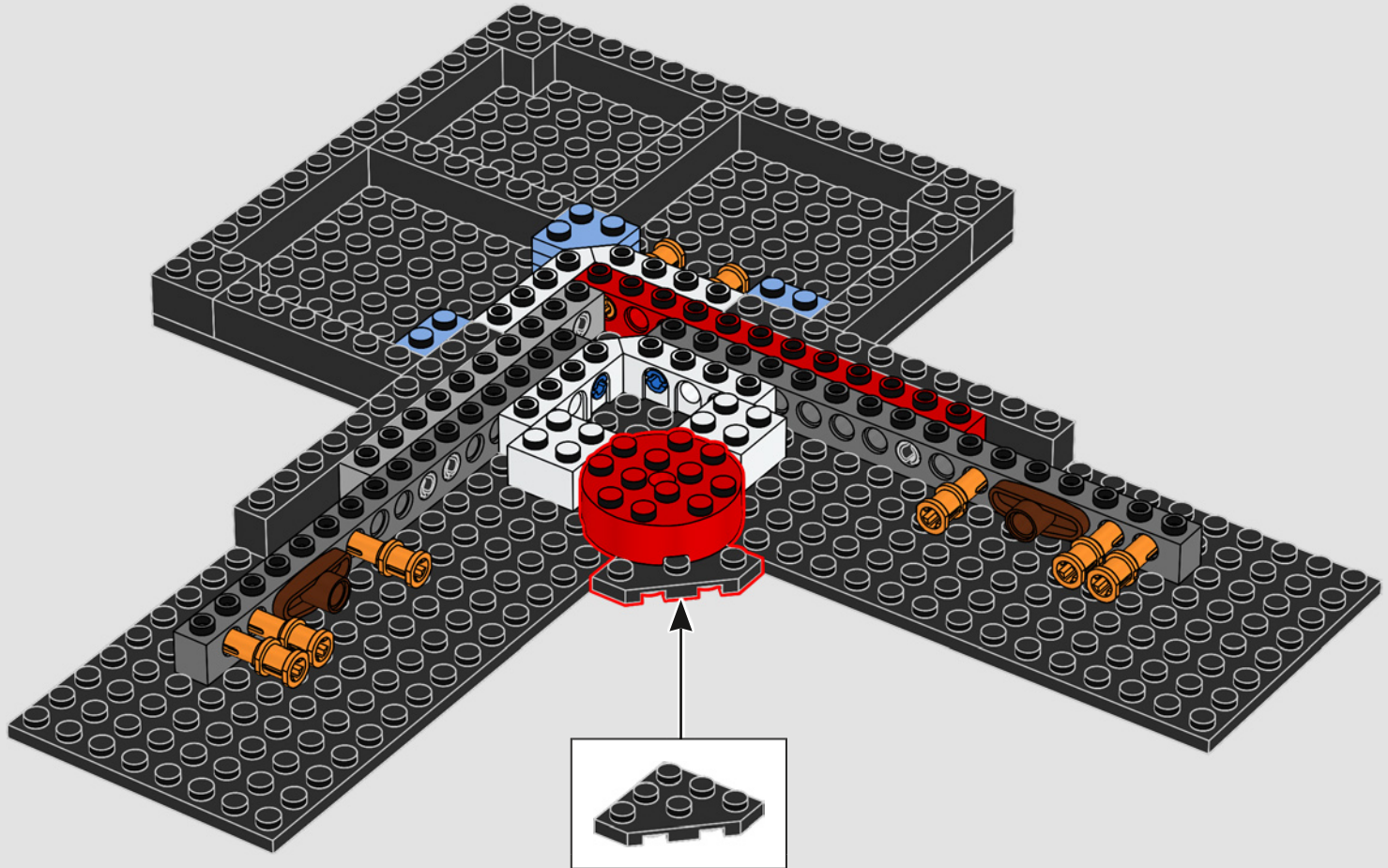

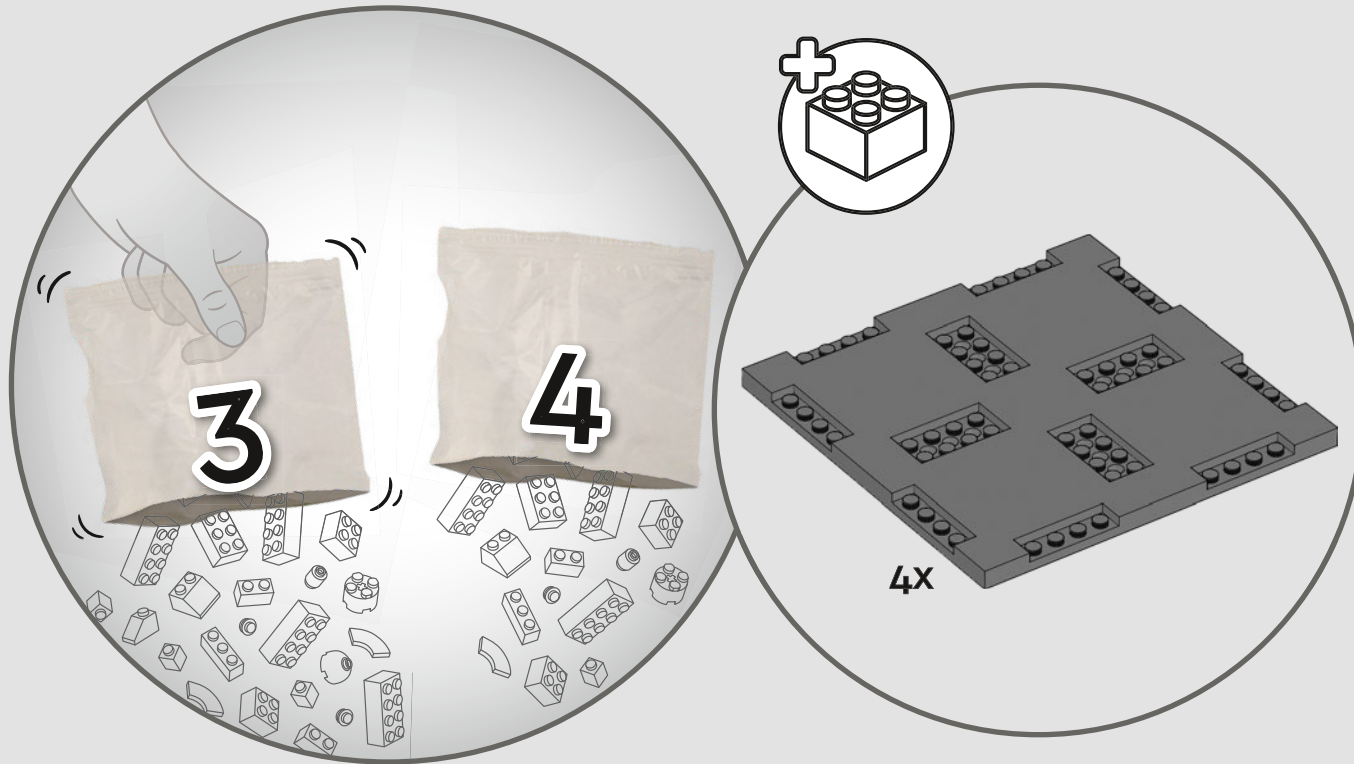

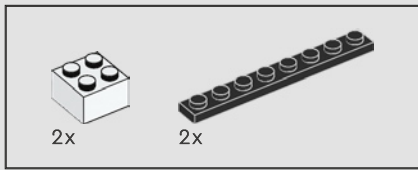

10

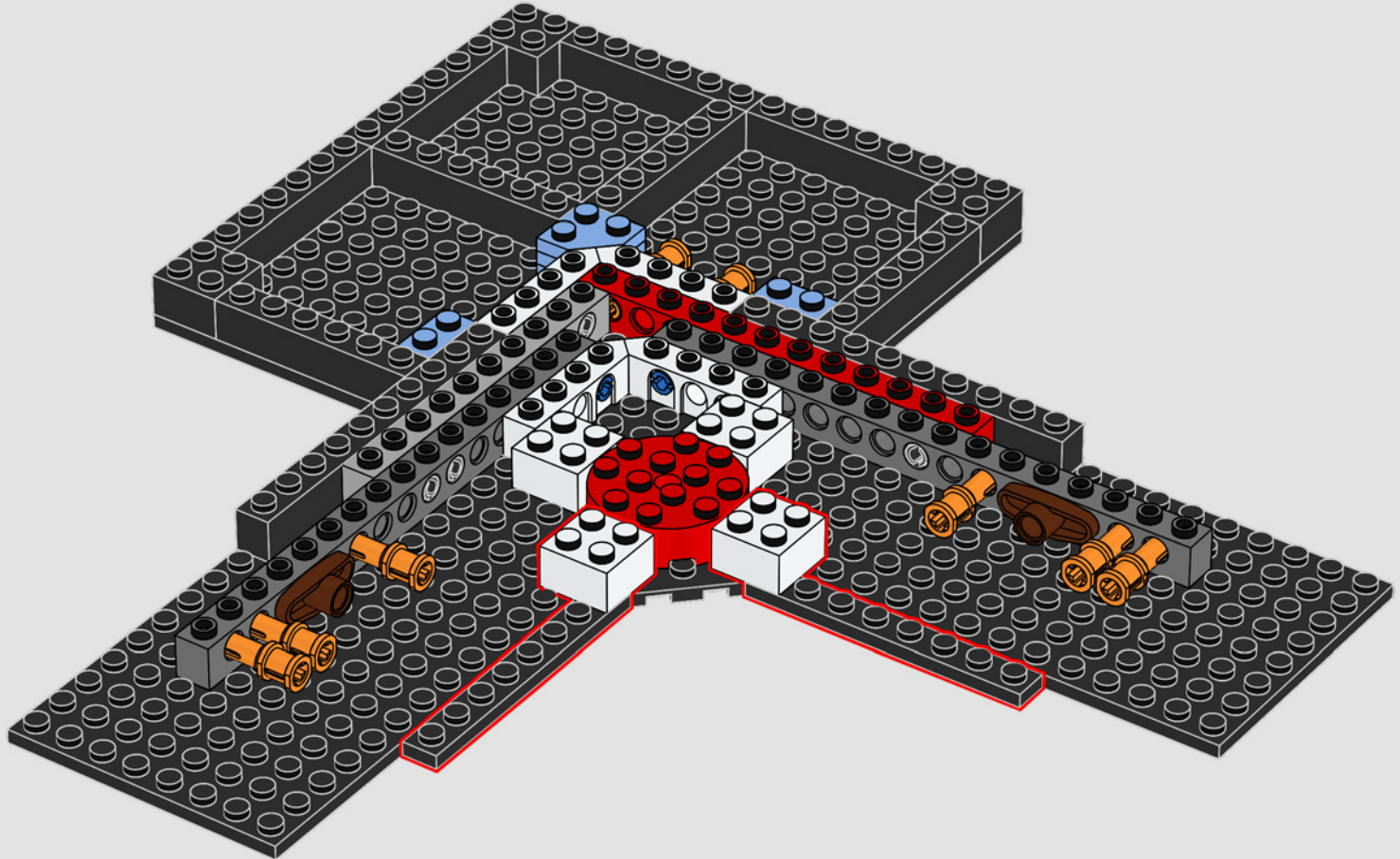

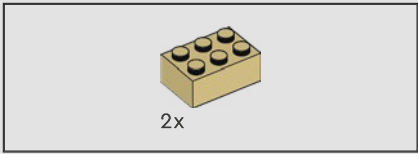

11

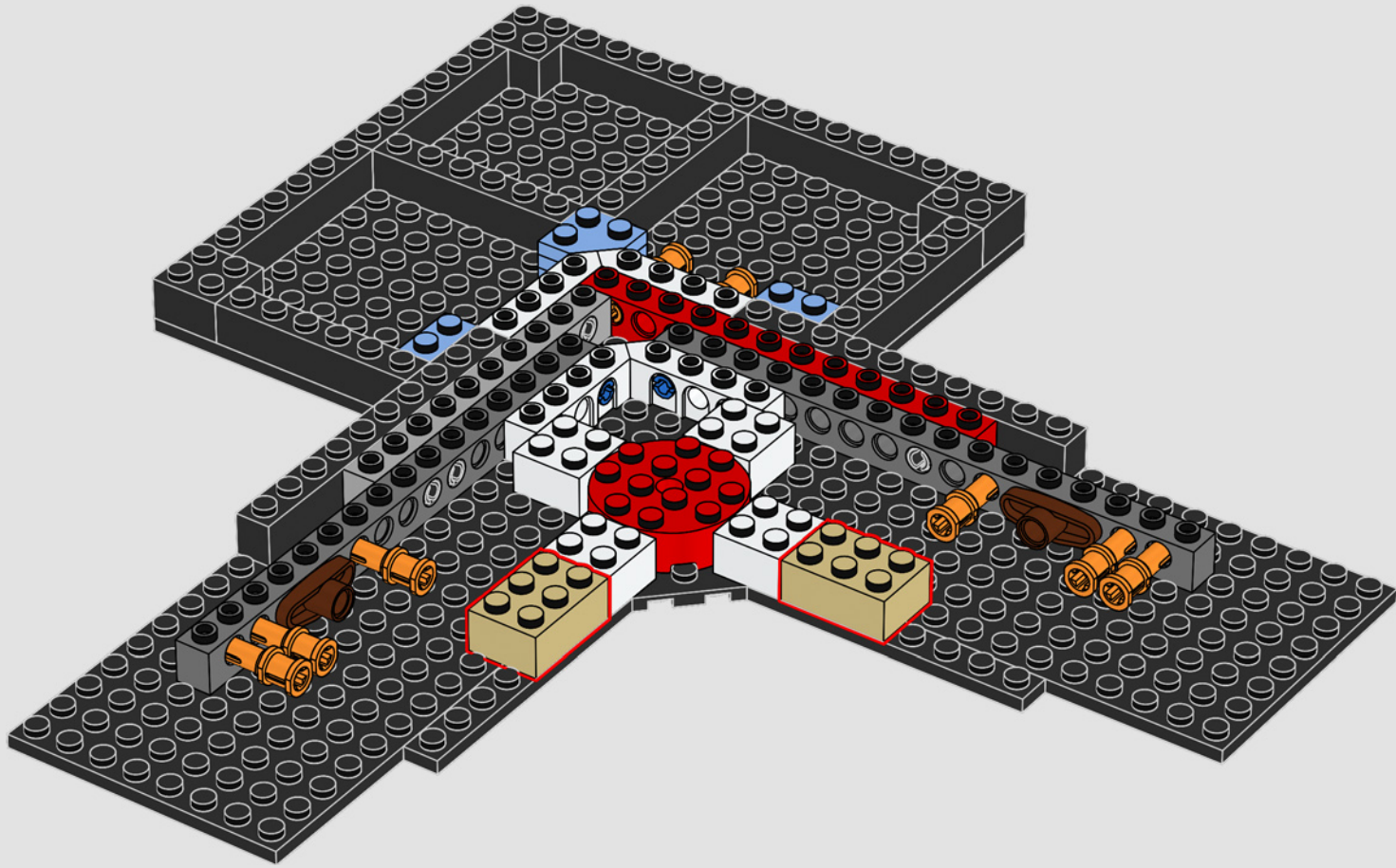

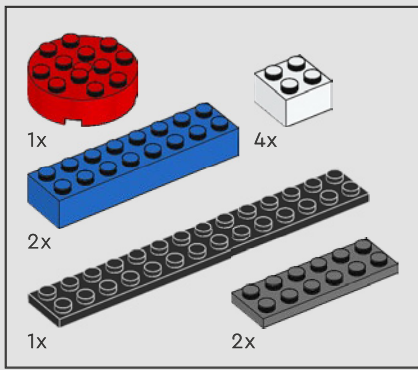

12

1

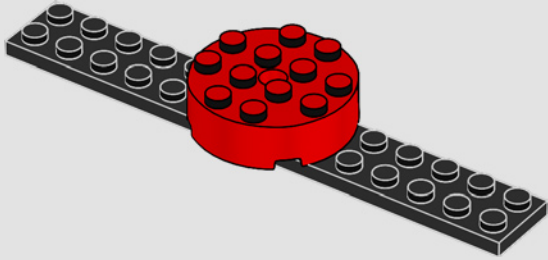

2

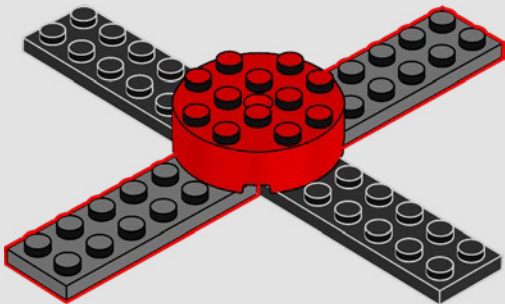

3

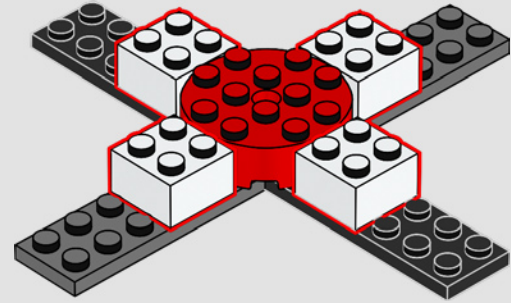

4

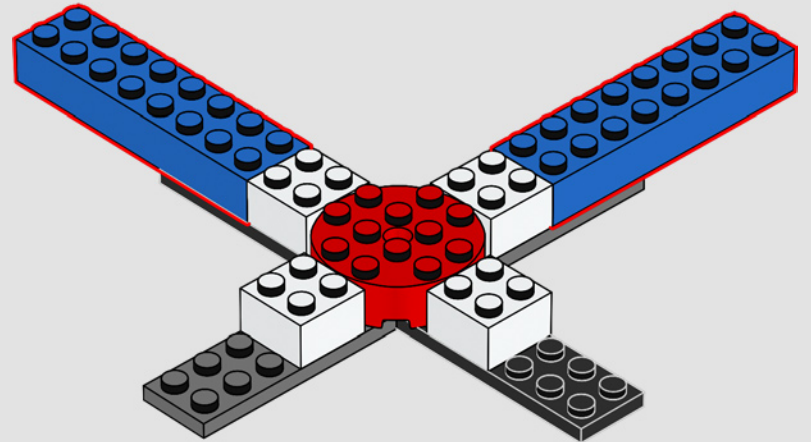

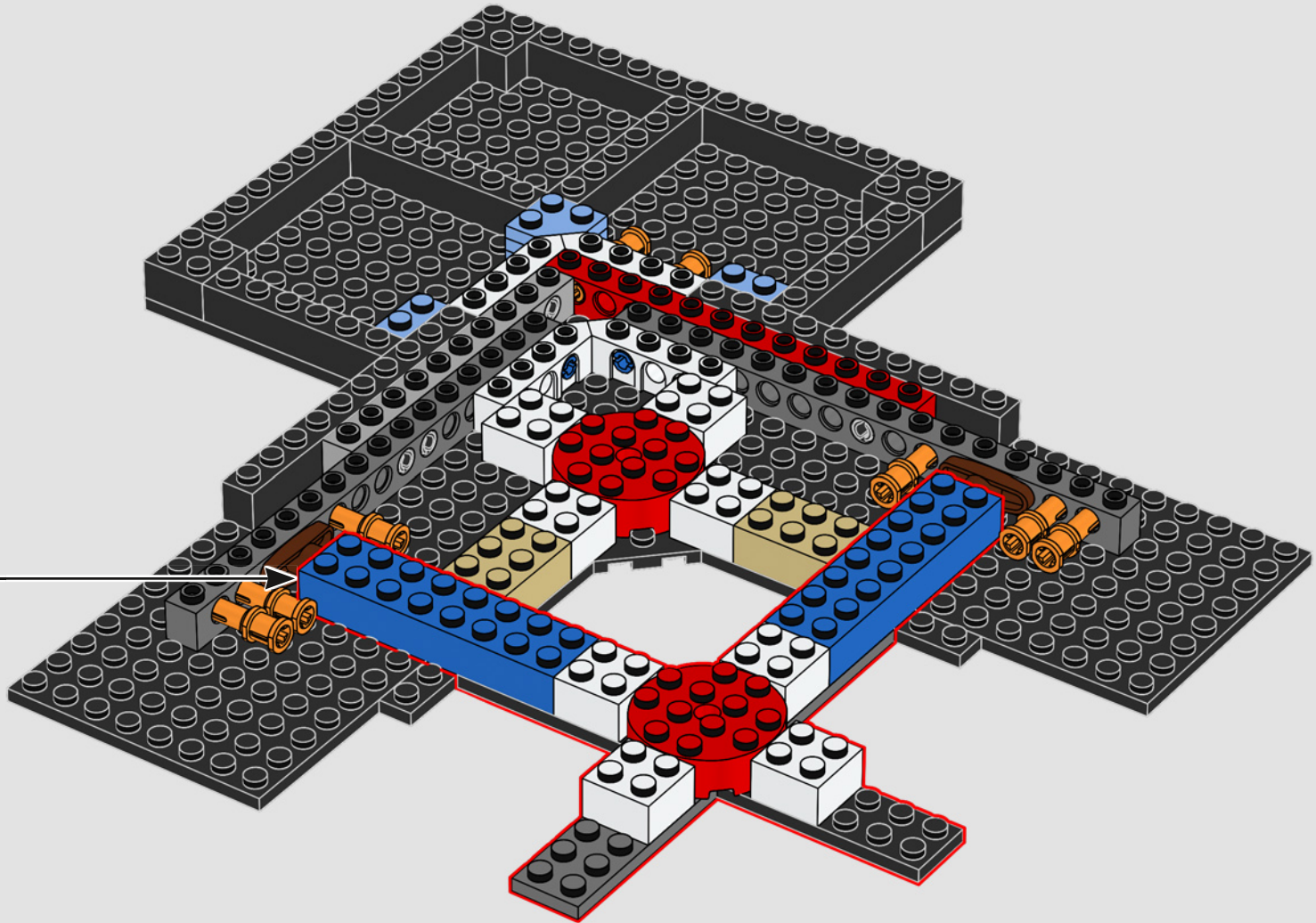

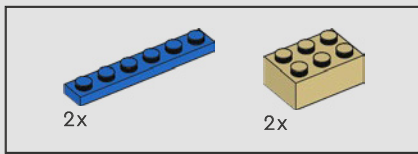

13

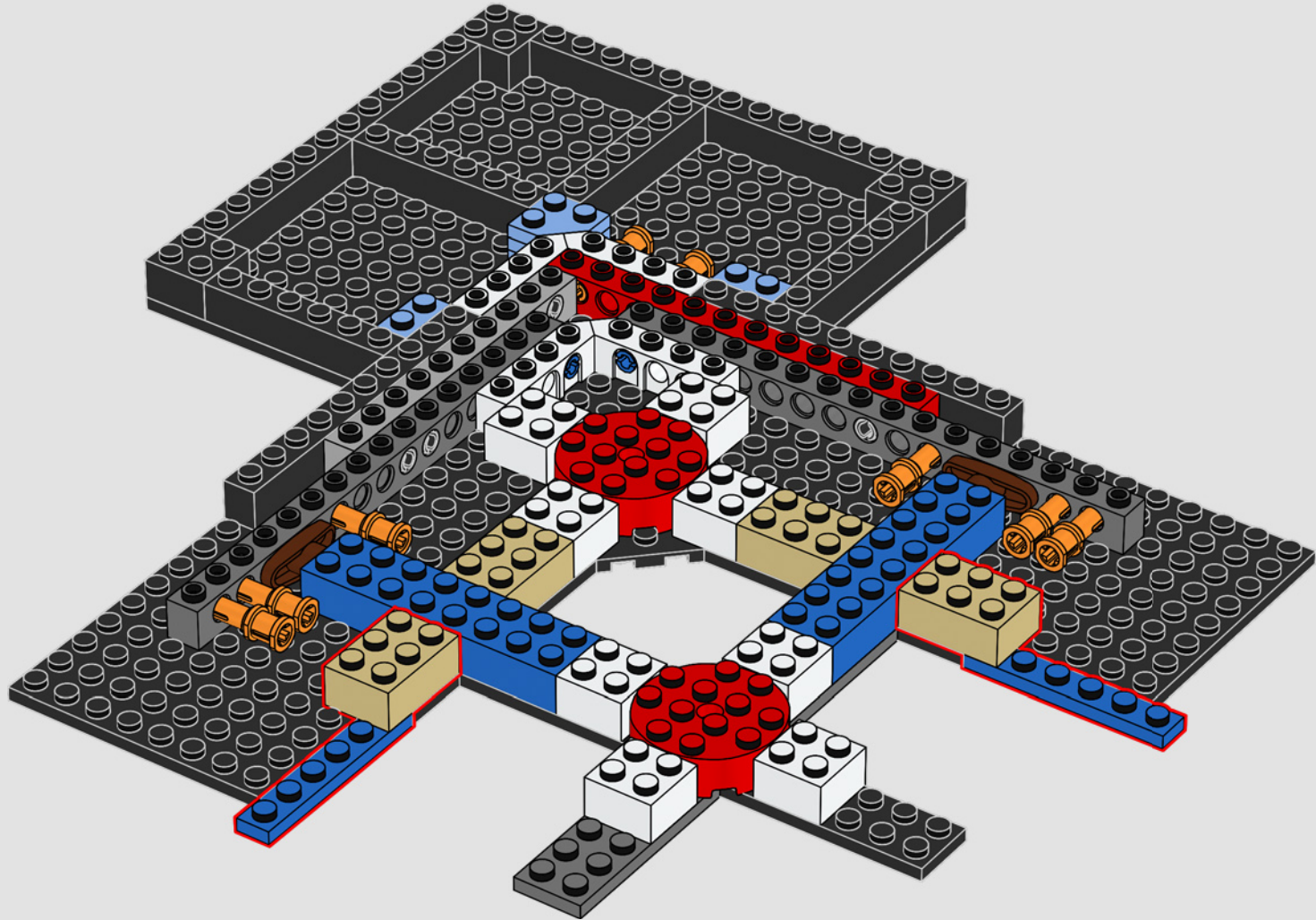

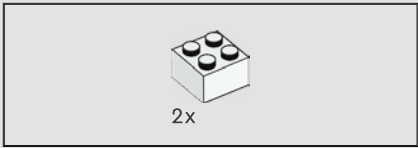

14

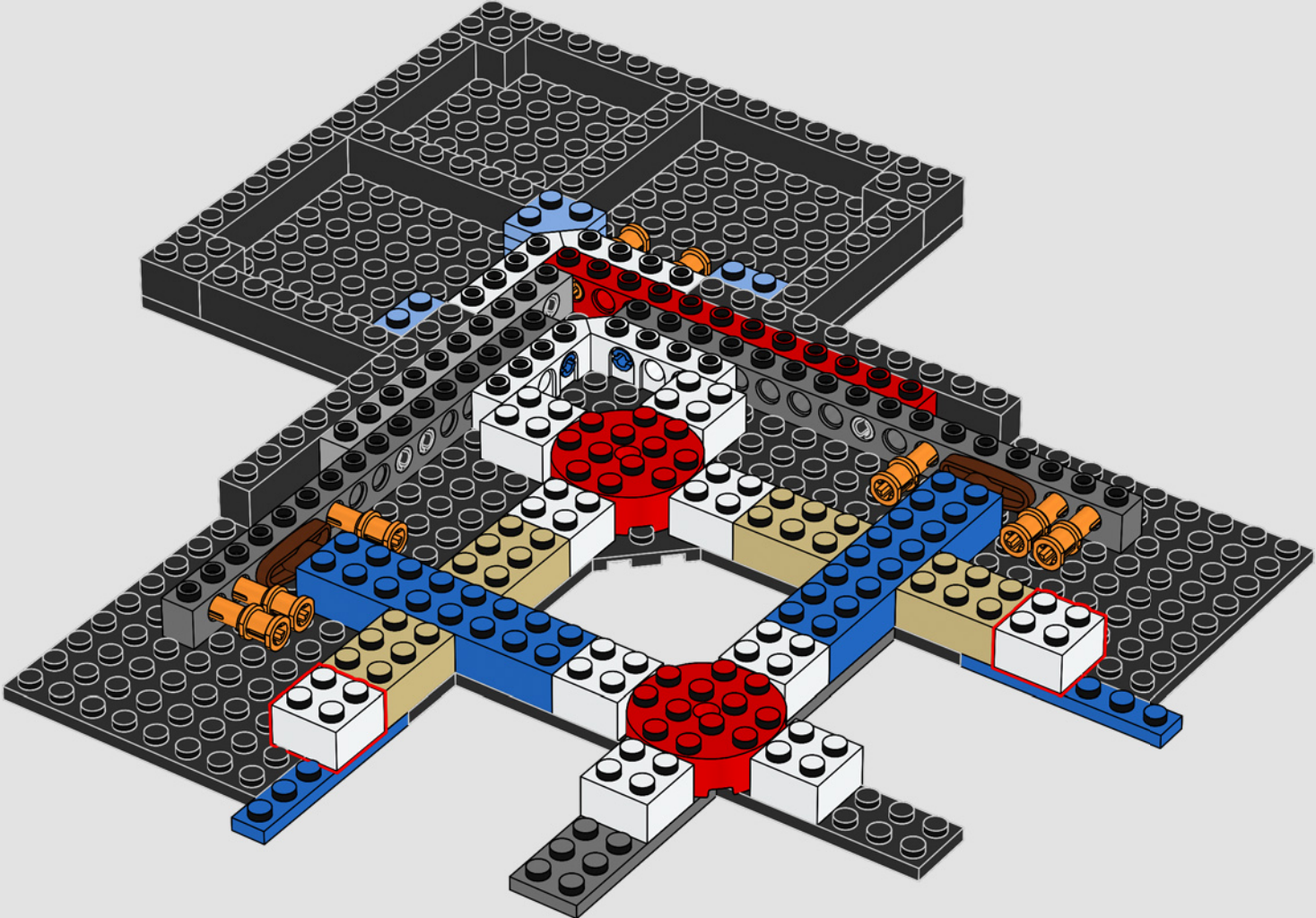

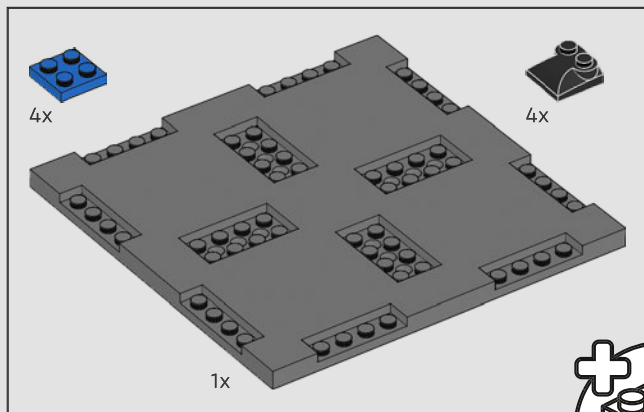

15

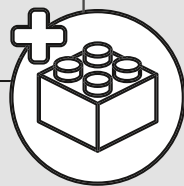

1

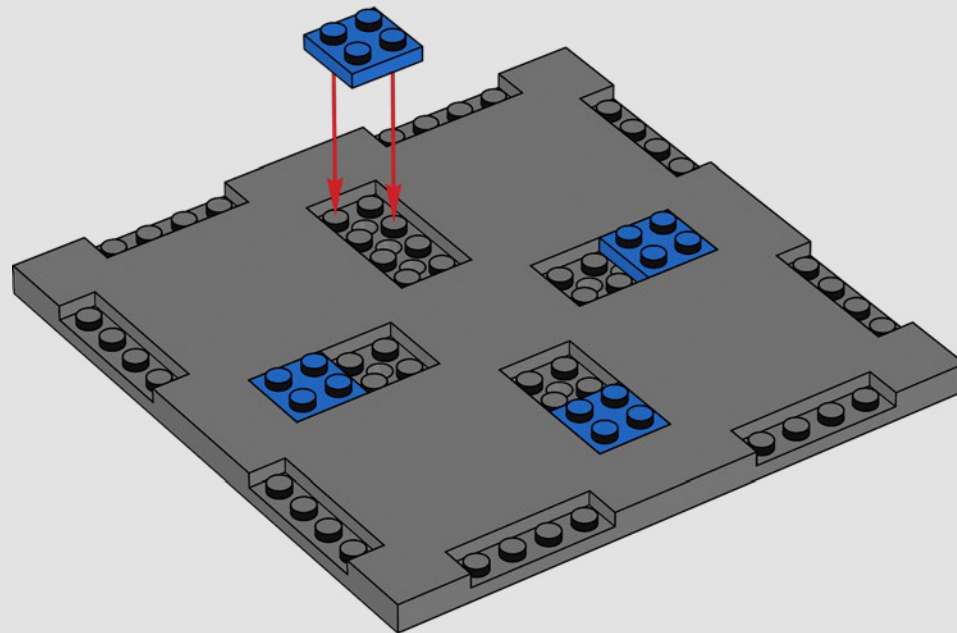

2

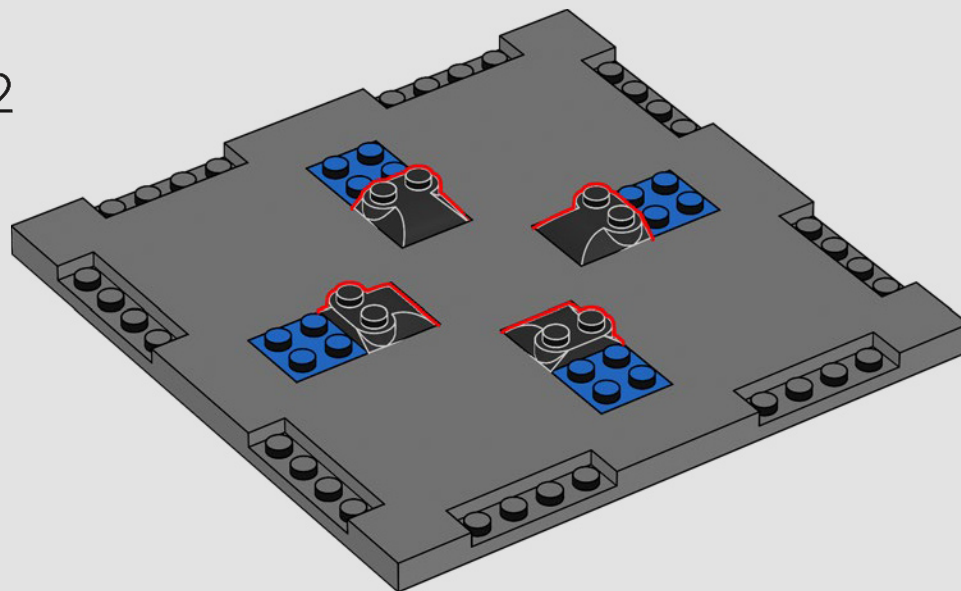

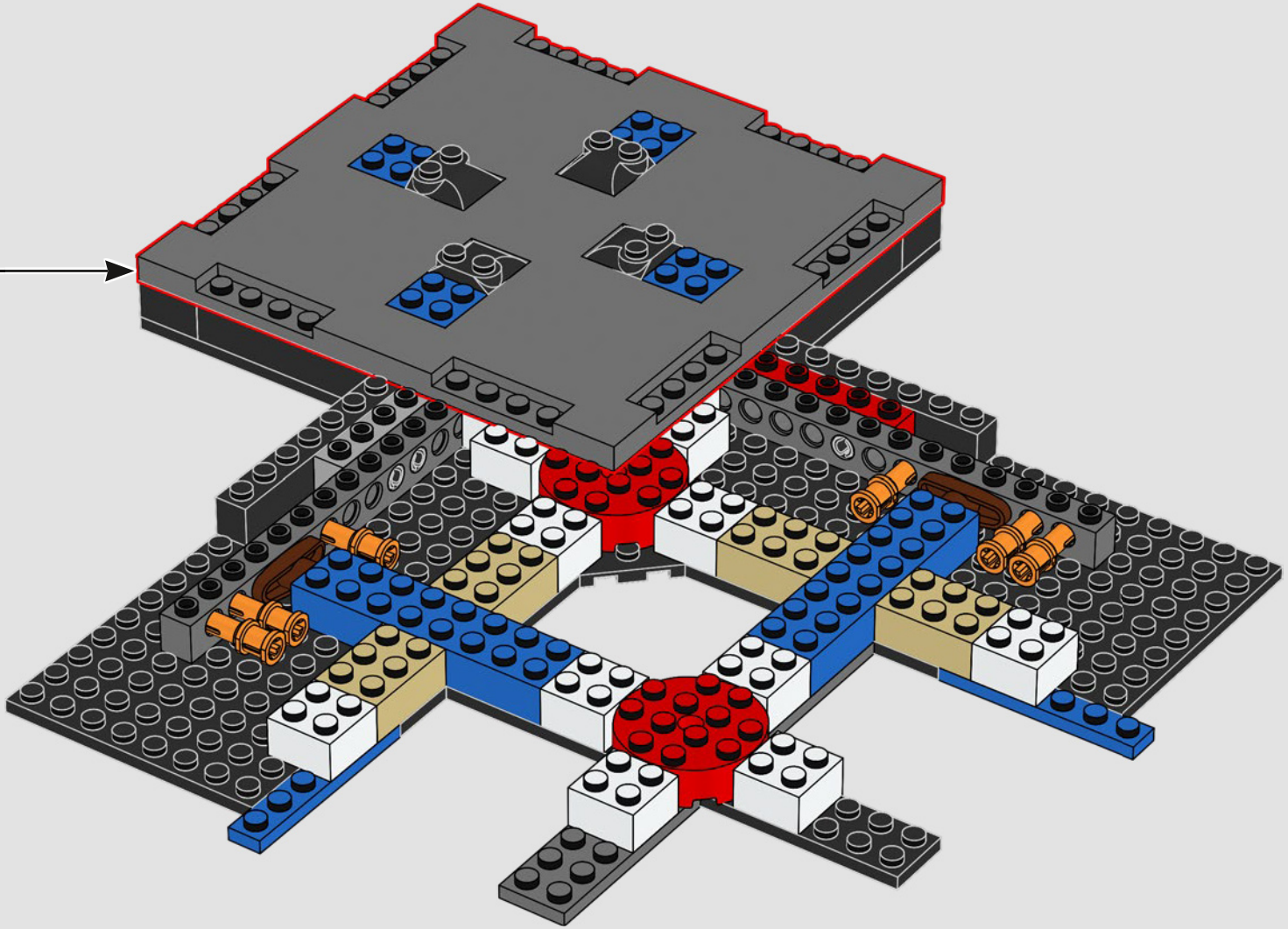

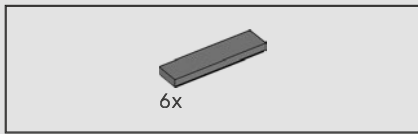

16

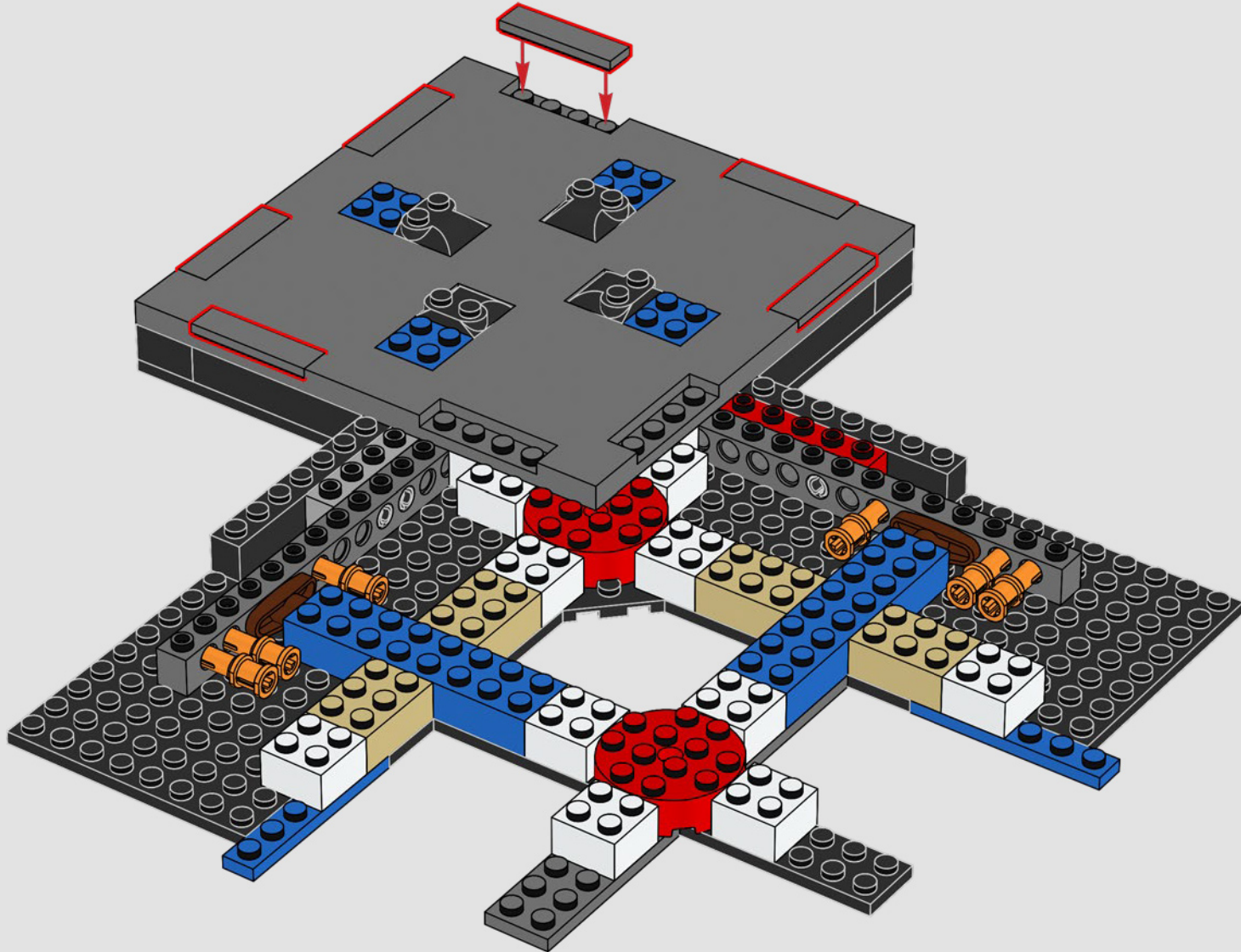

4x

17

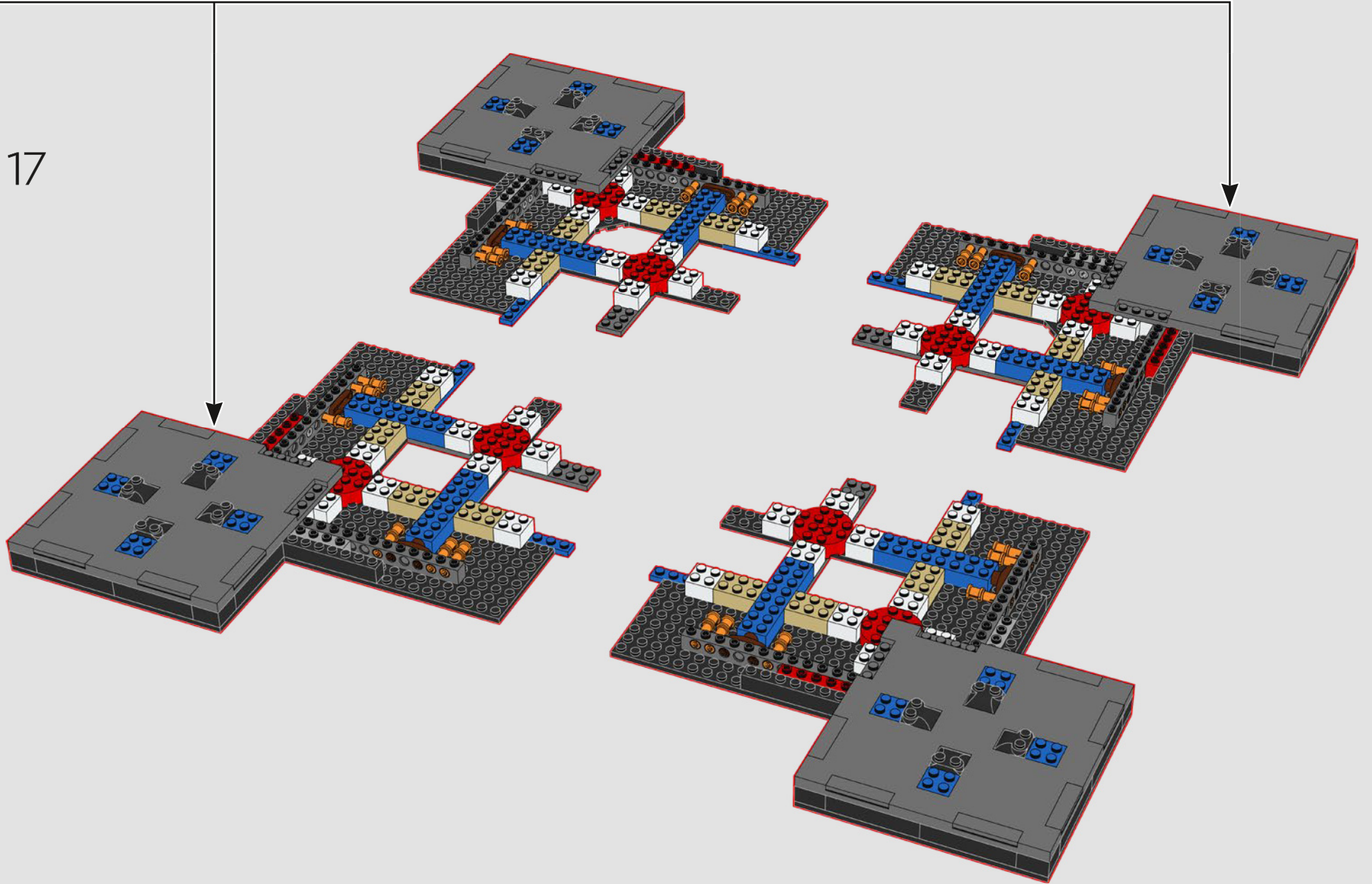



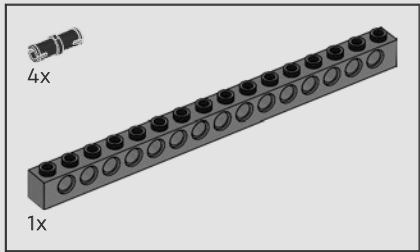
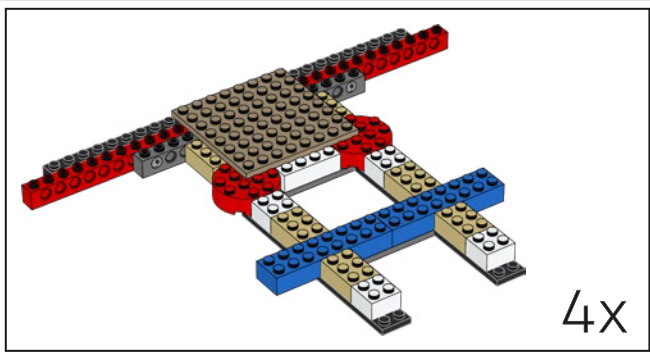

18

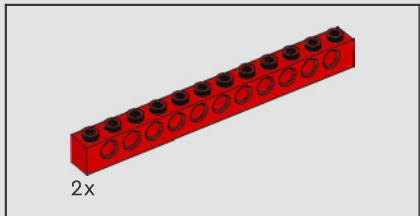
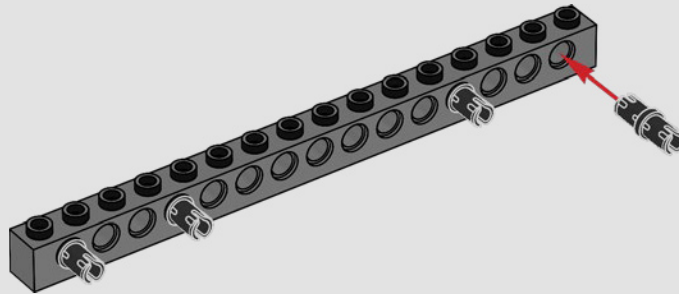

19

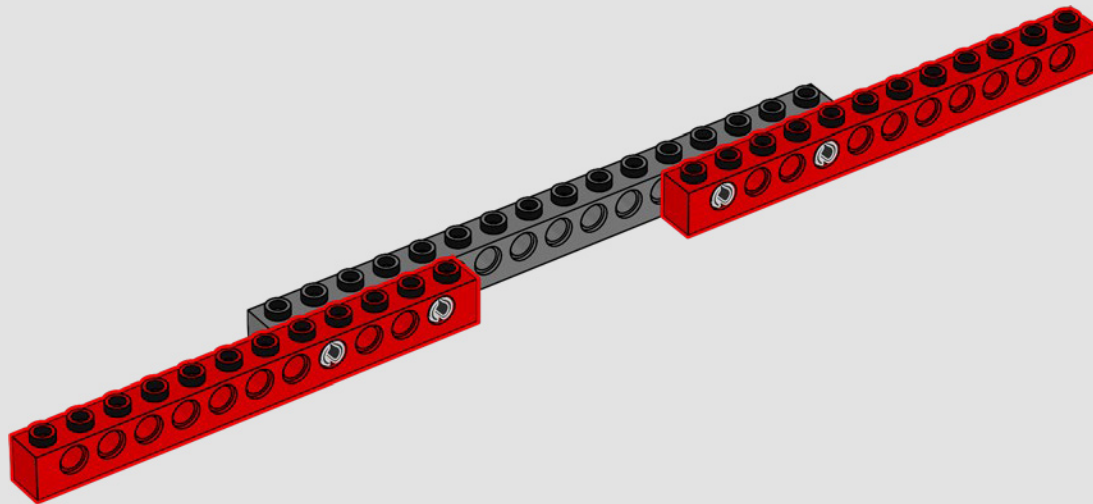

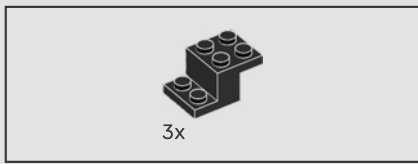

20

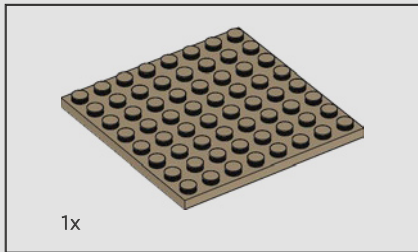
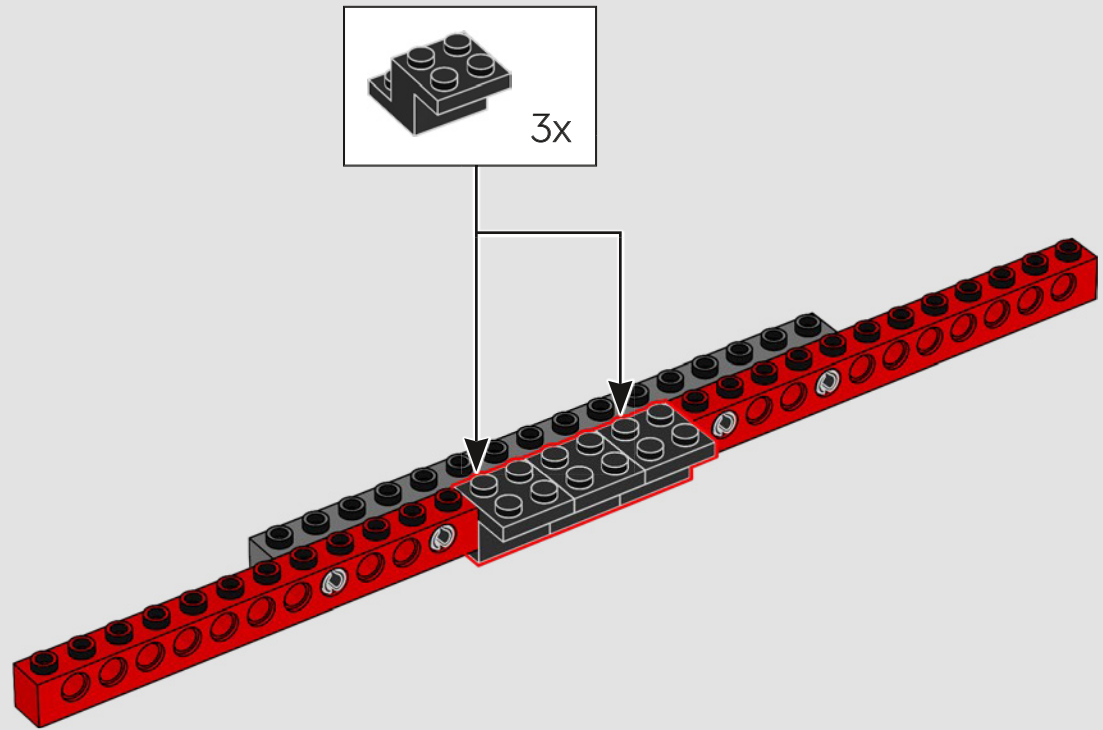

21

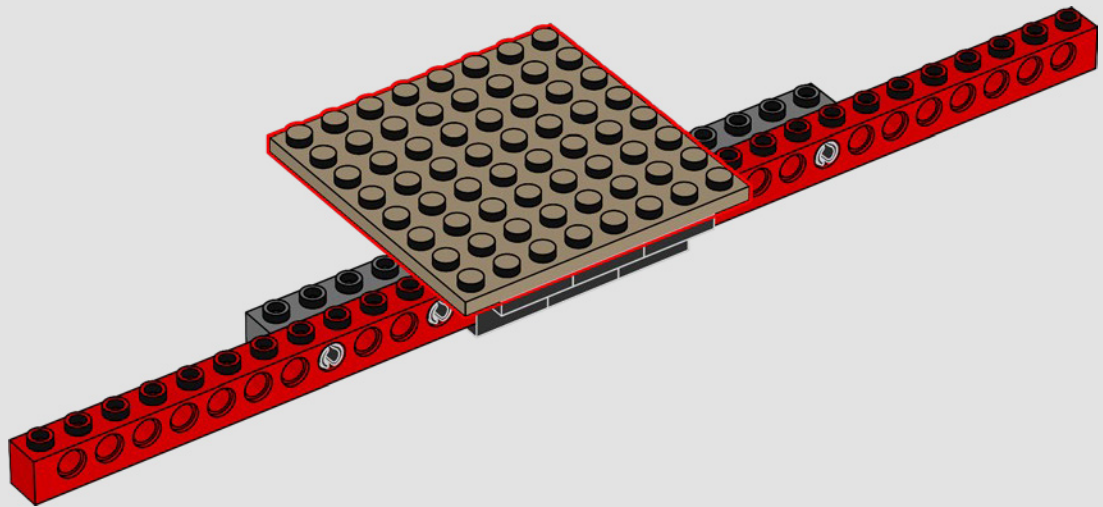

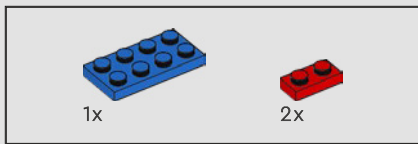

22

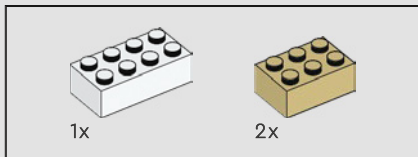
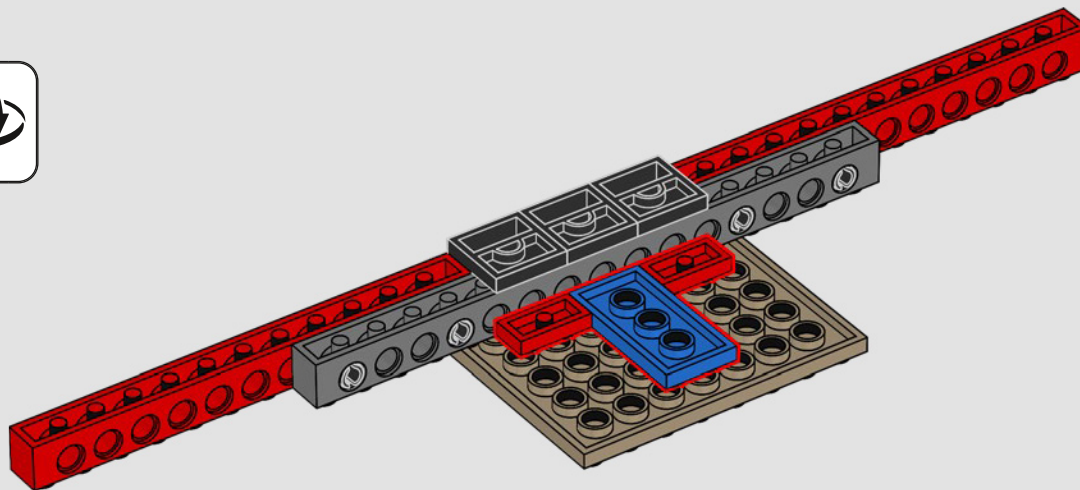

23

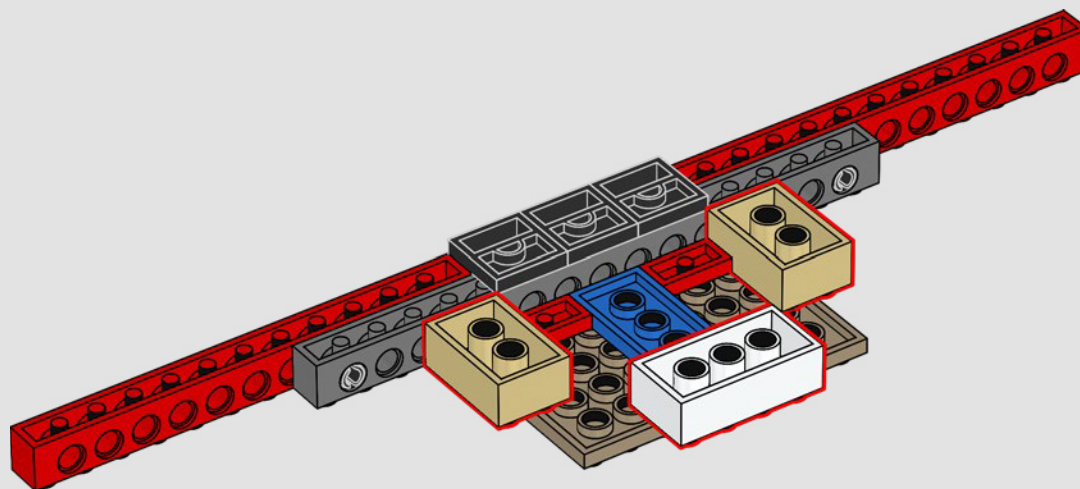



24

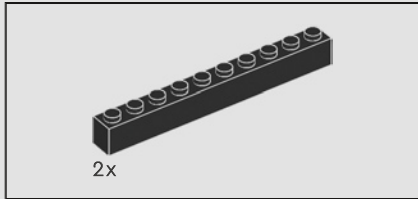
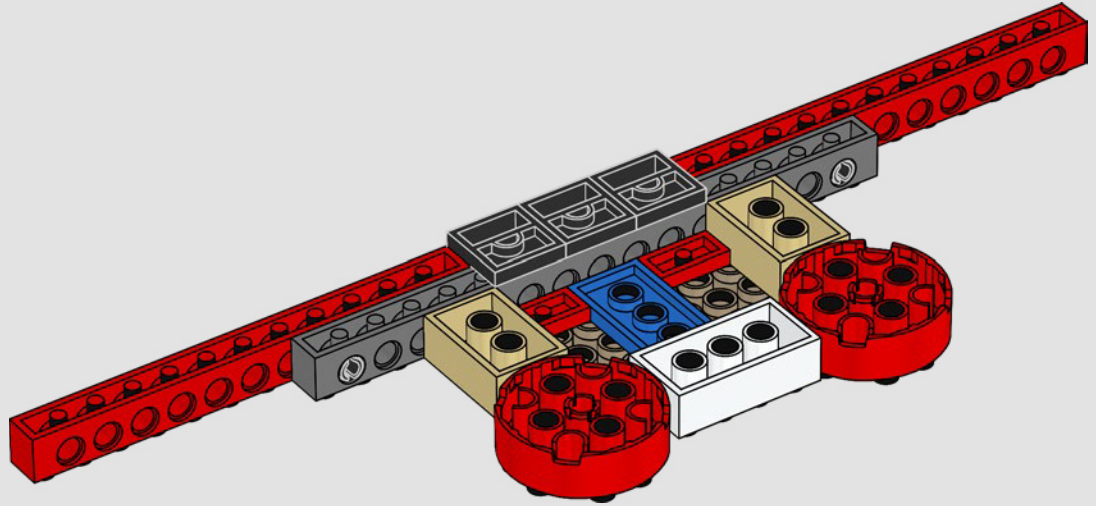

25

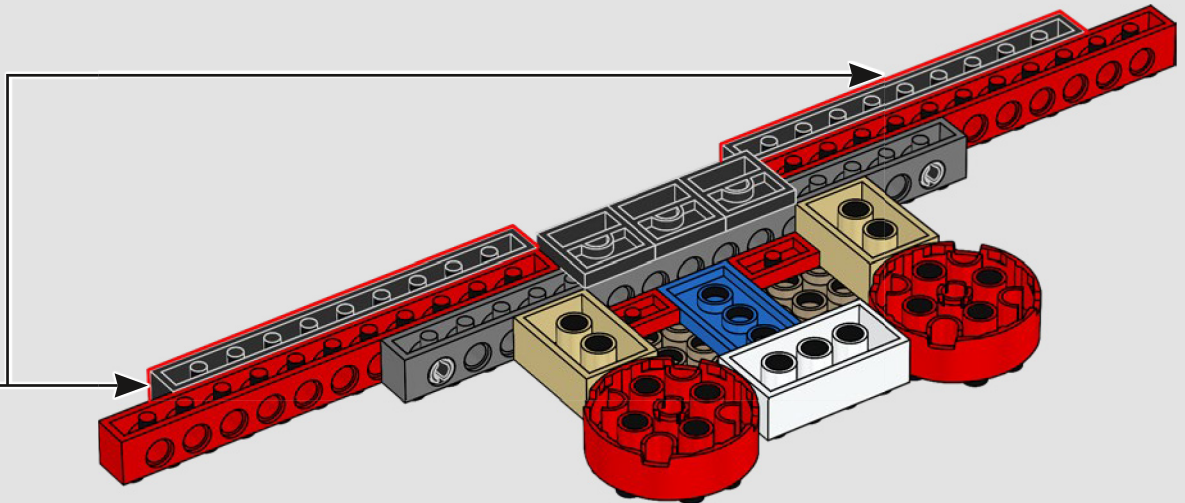
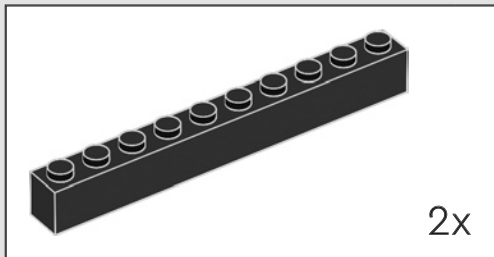

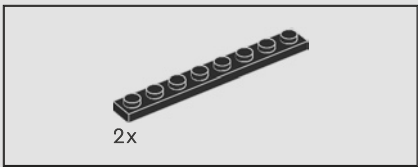

26

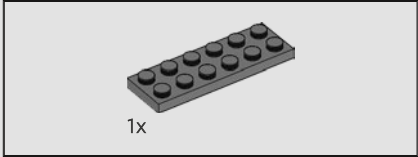
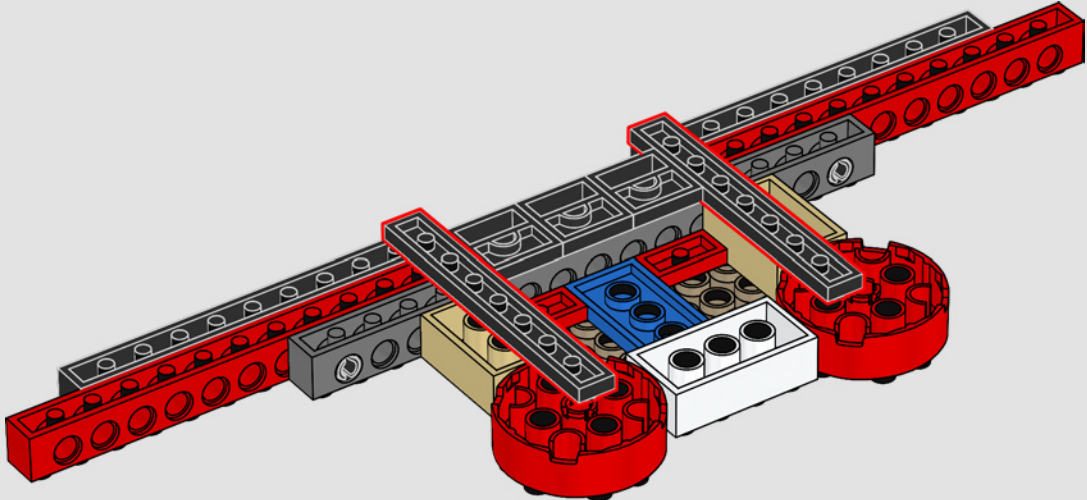

27

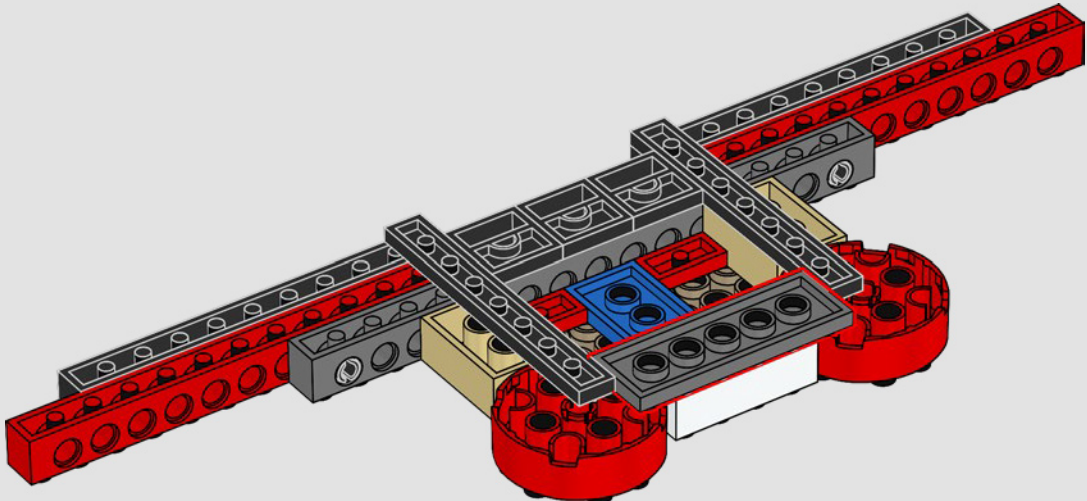

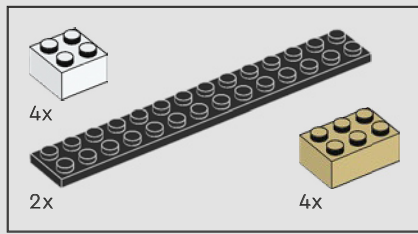

28

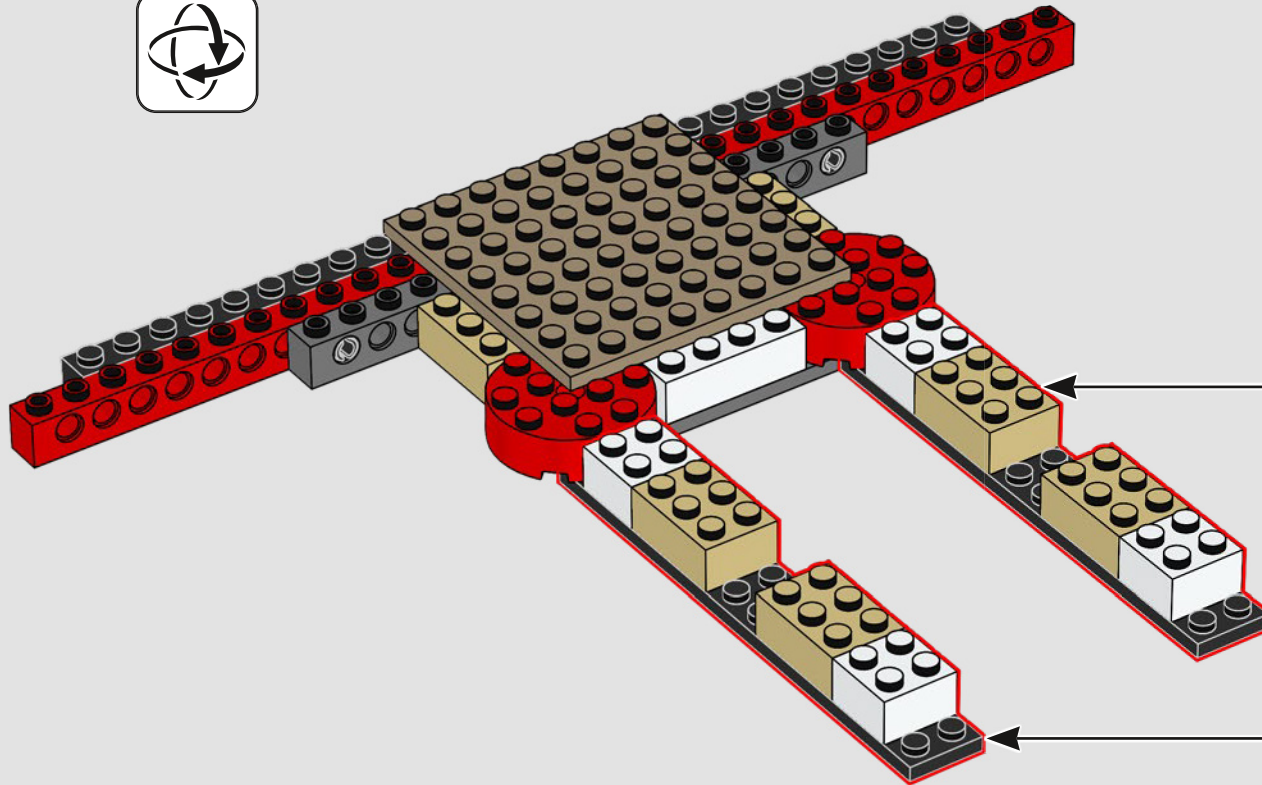
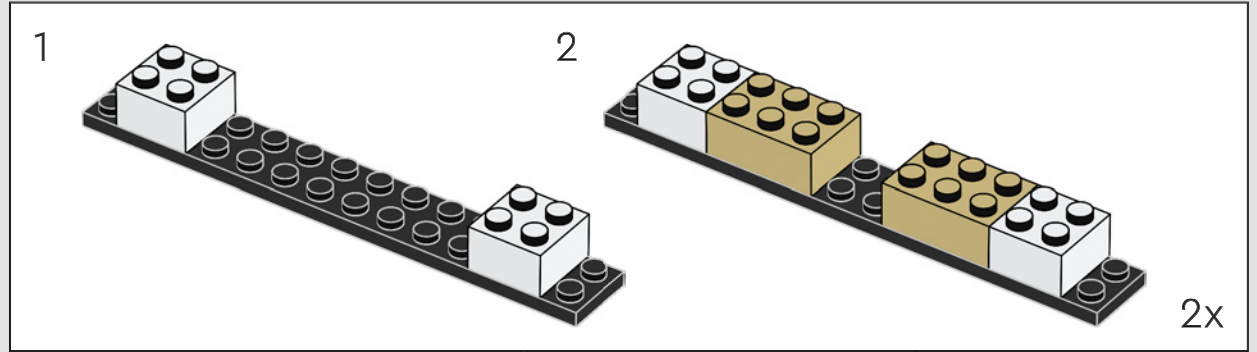

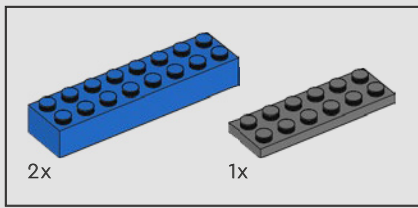

29

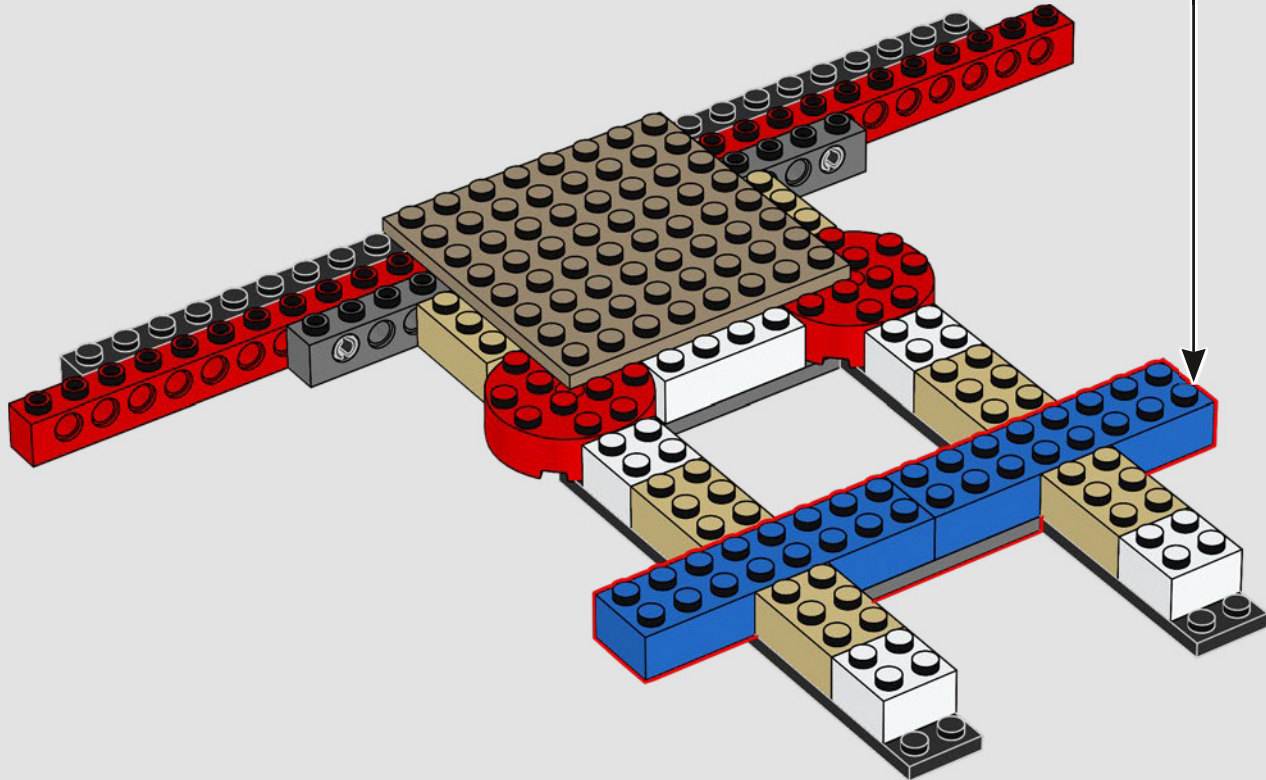
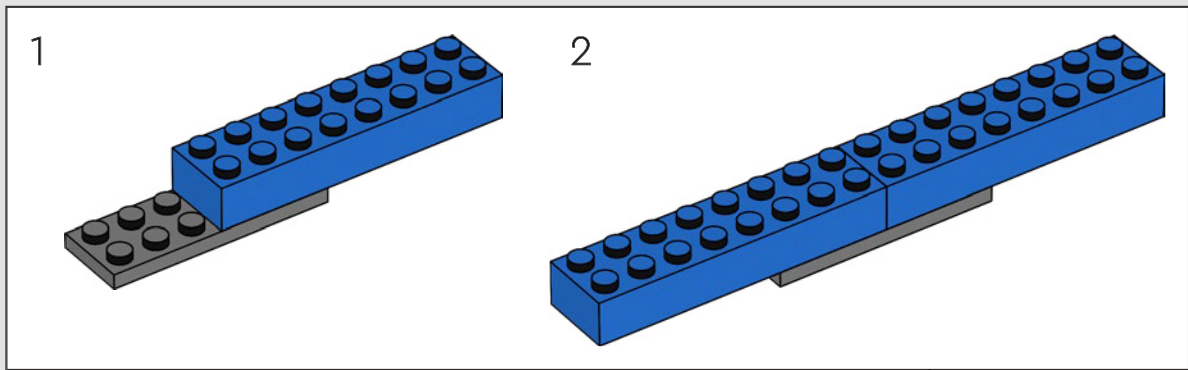

30

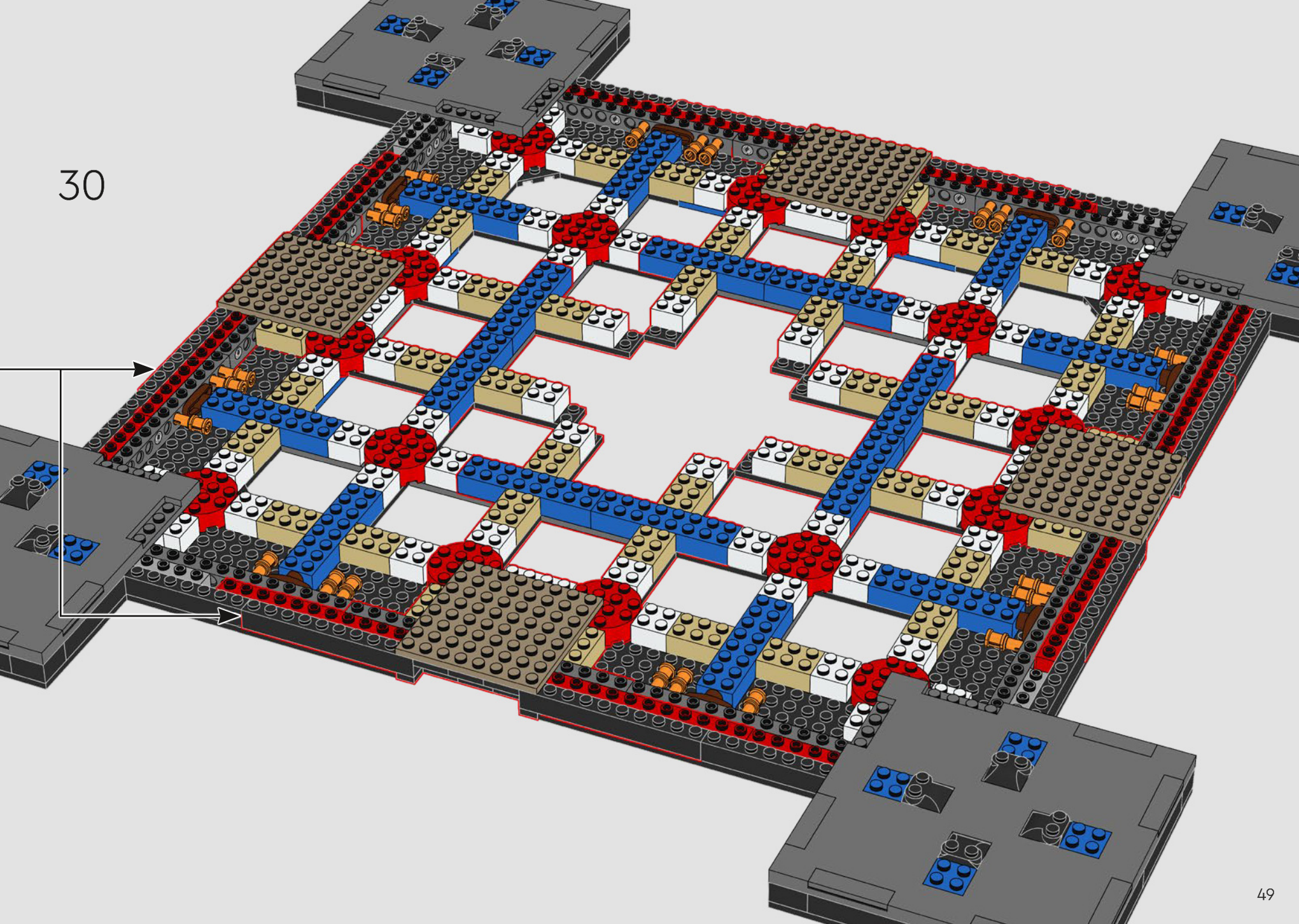

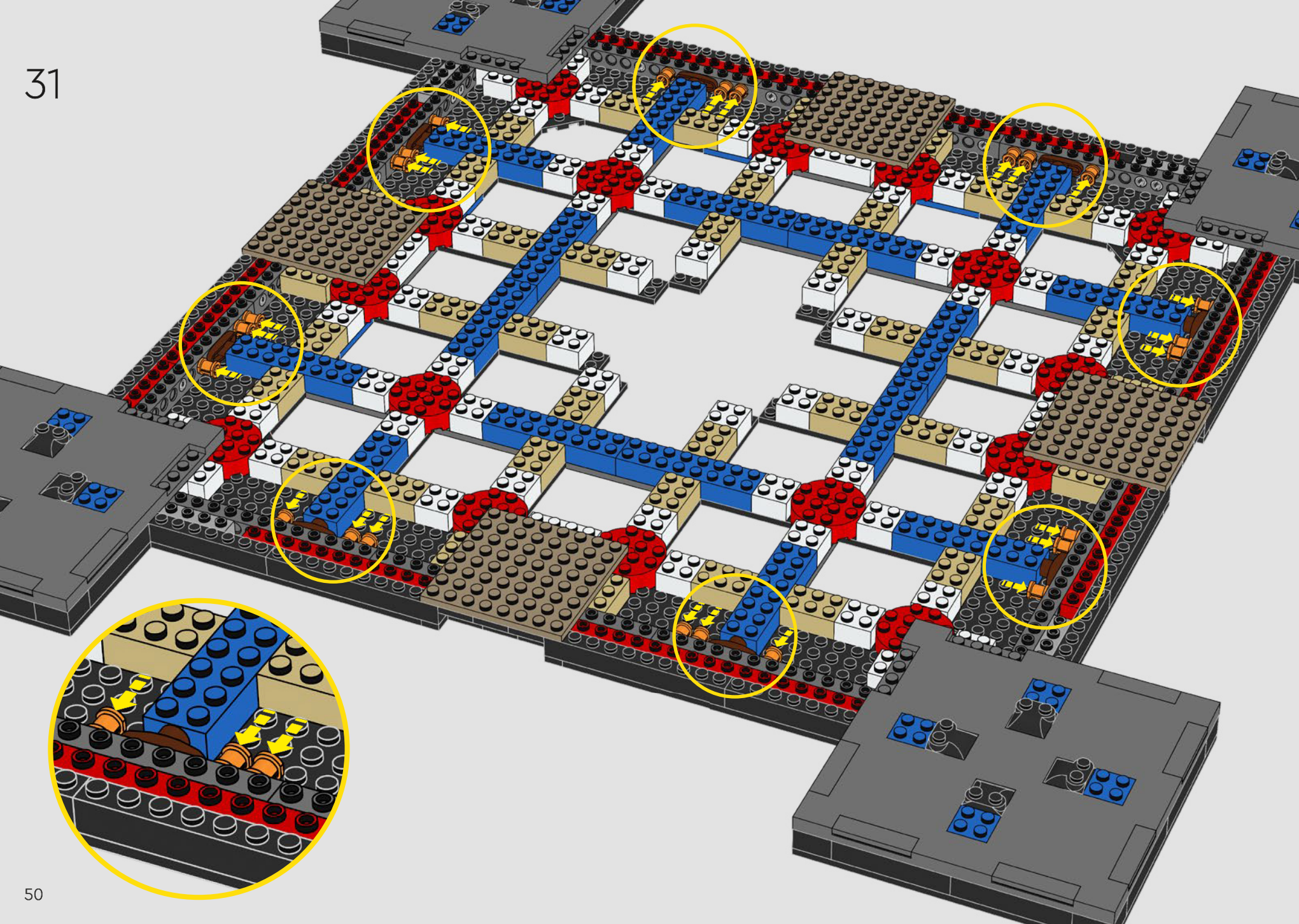

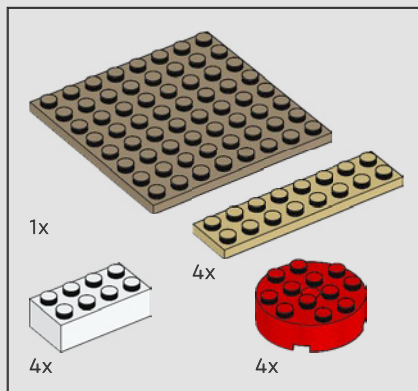

32

1

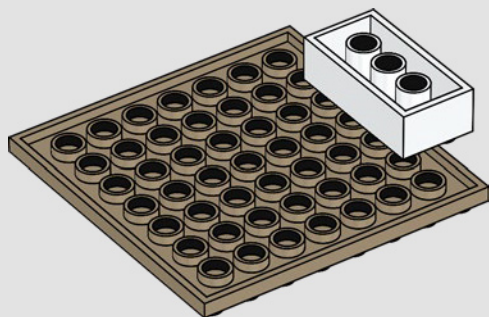

2

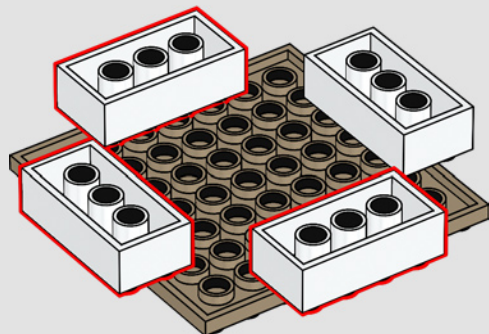

3

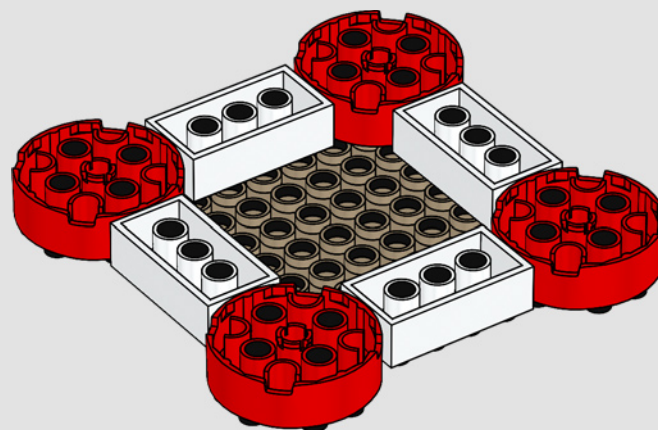

4

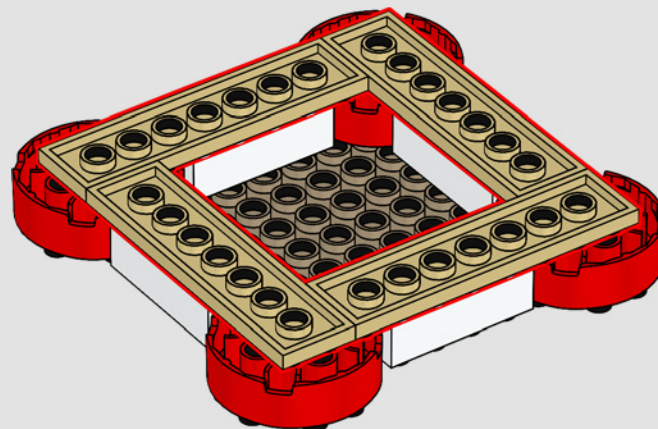

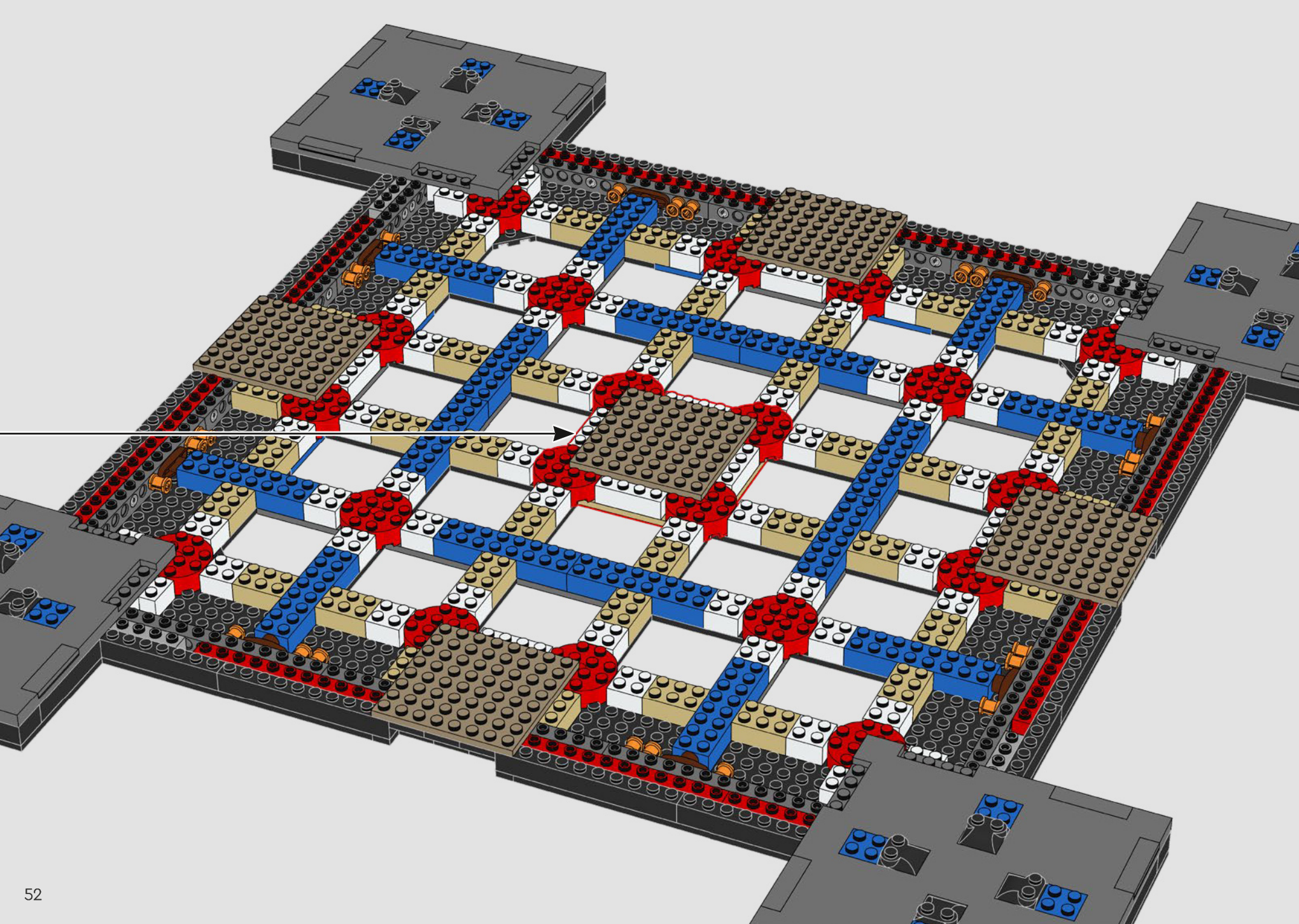

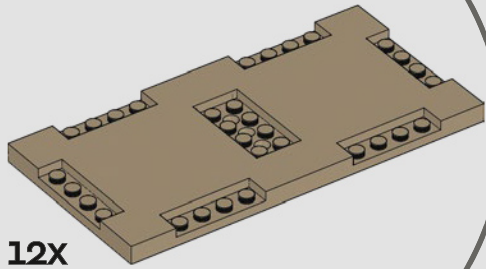
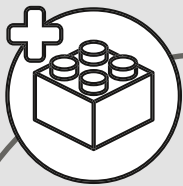

12X

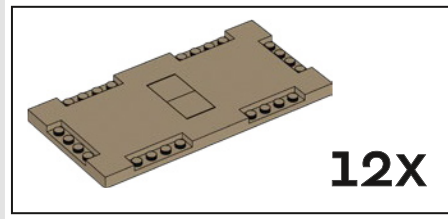

12X

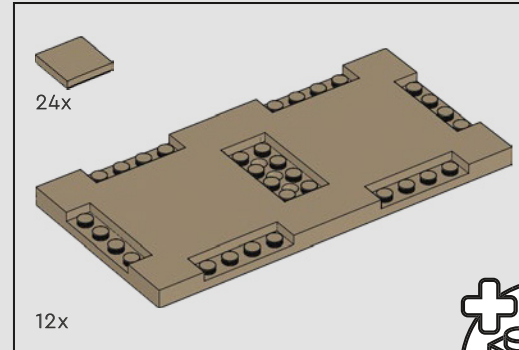

24x

12x

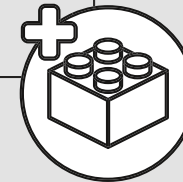

33

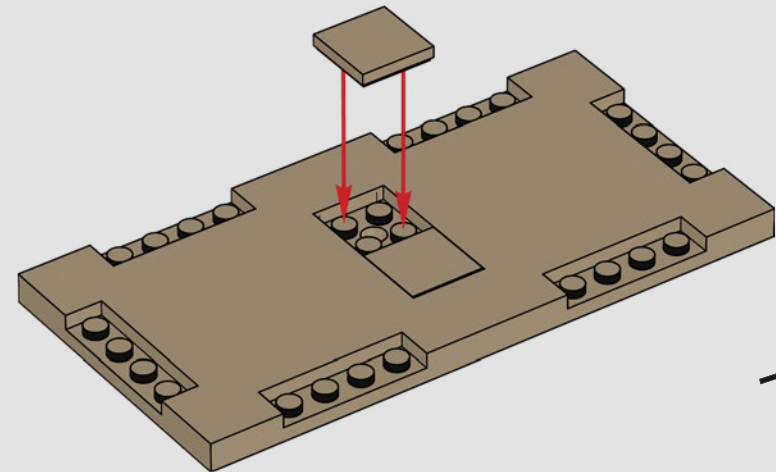
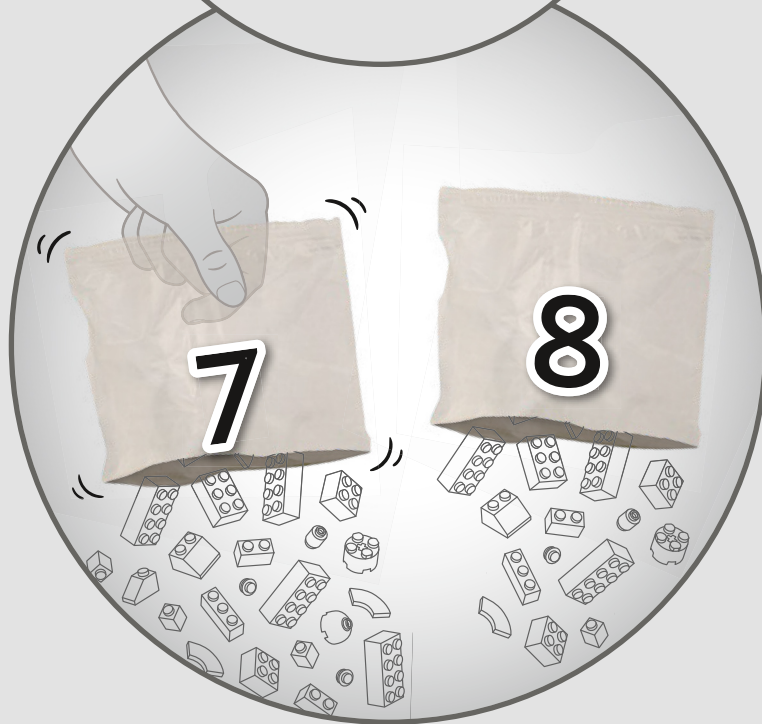

12x

34

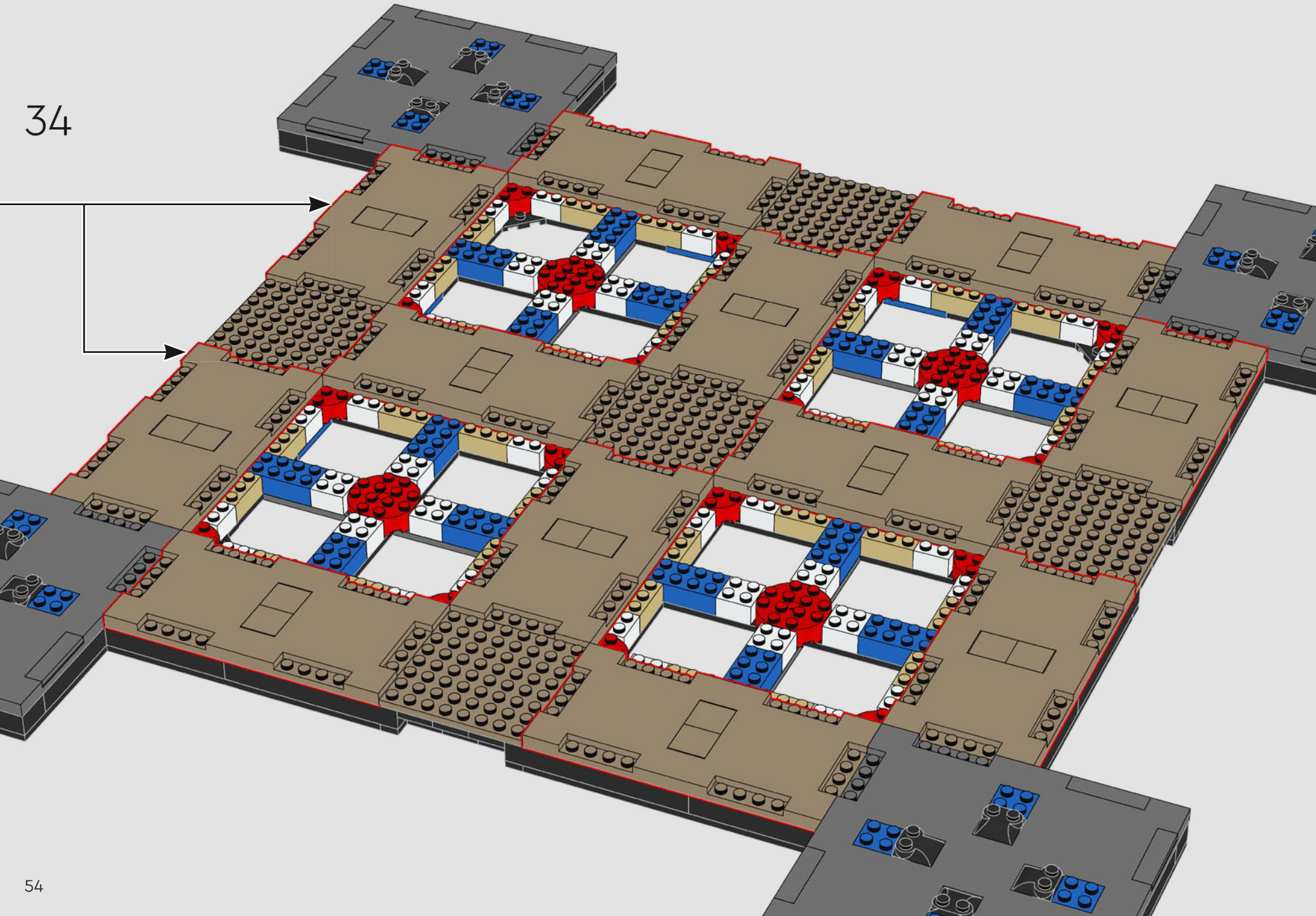

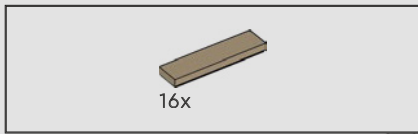

35

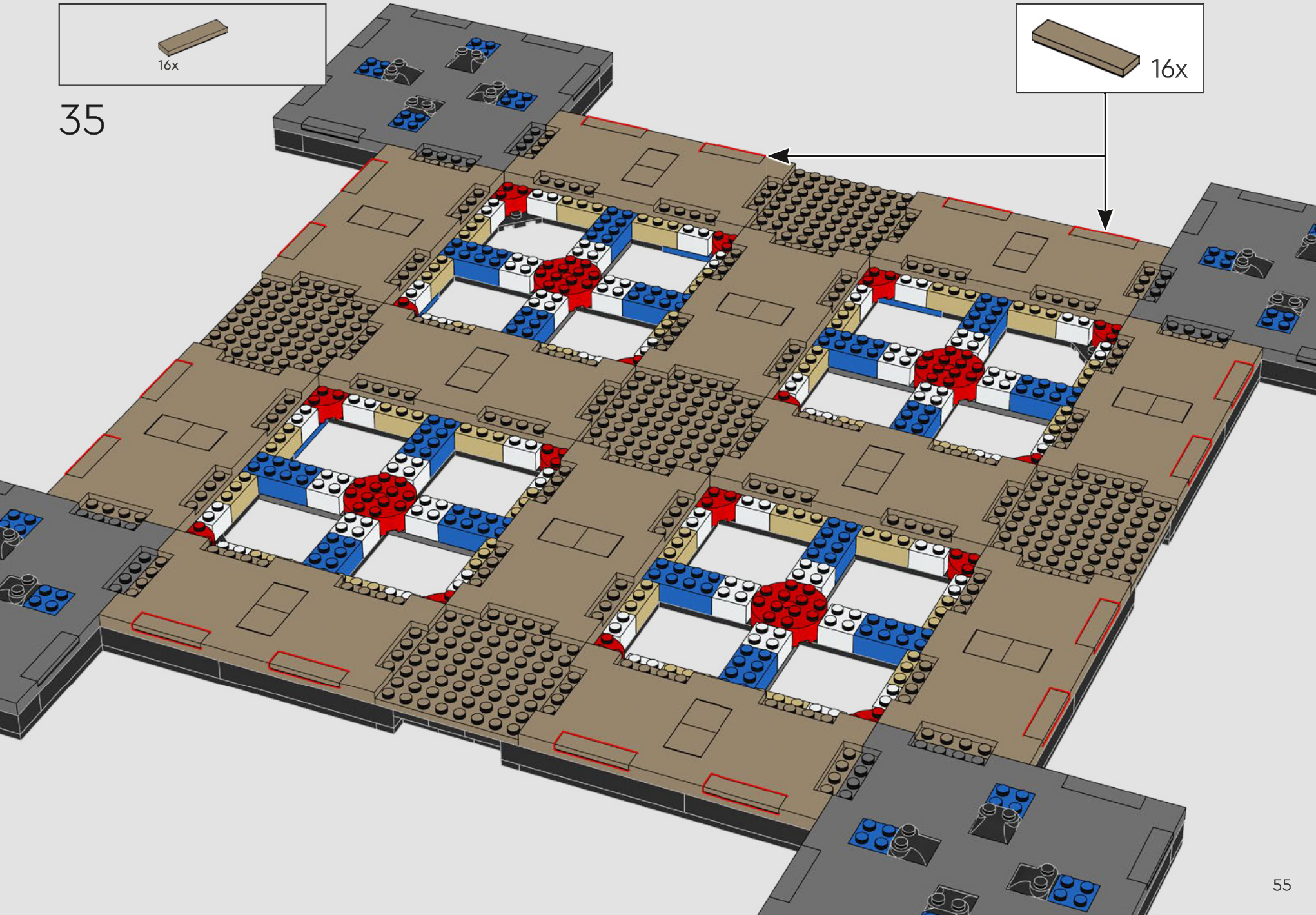
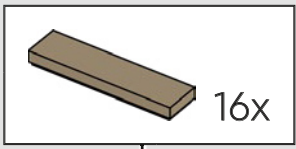

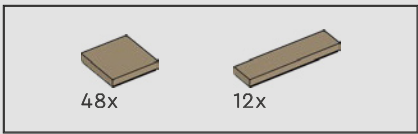

36

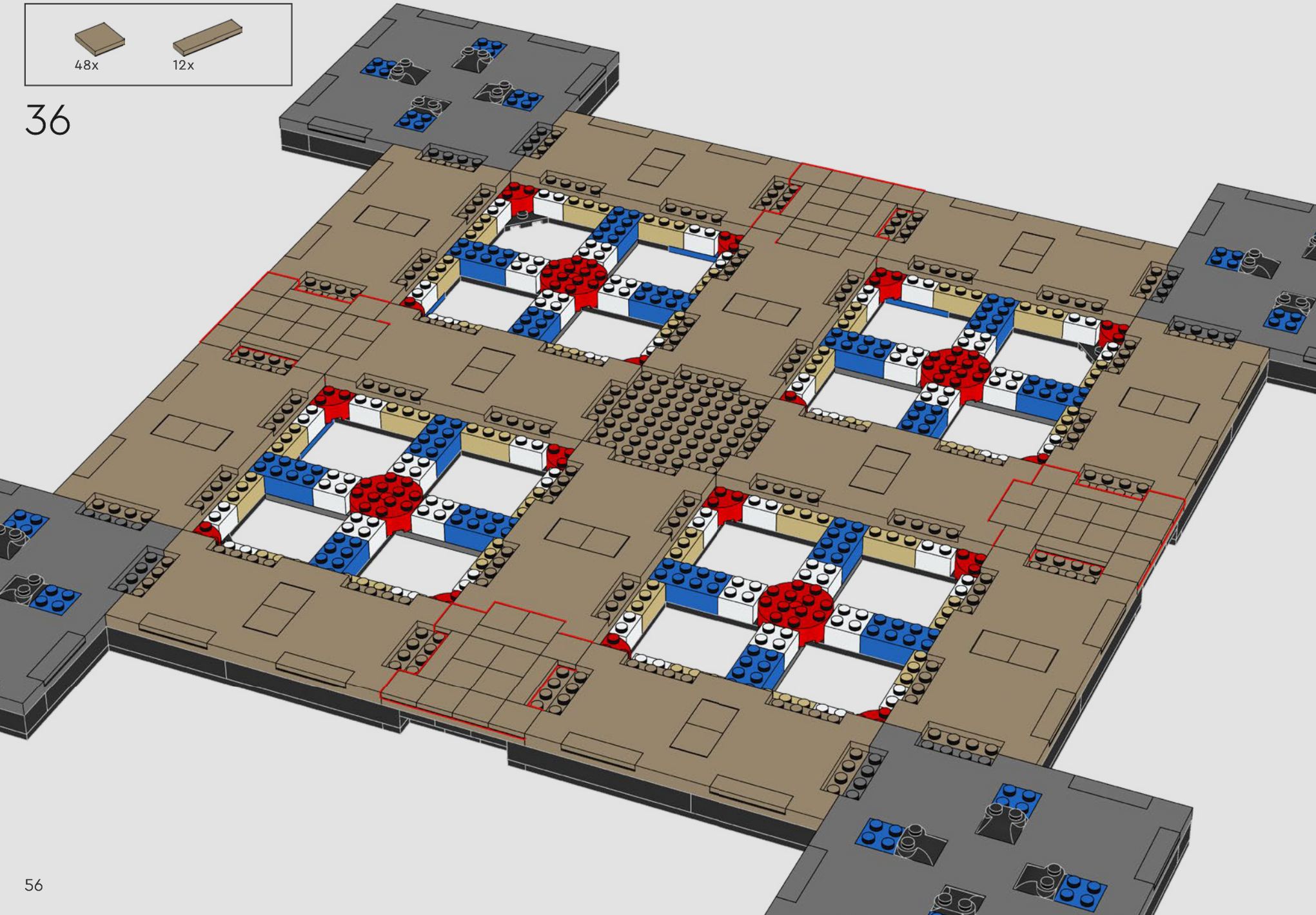

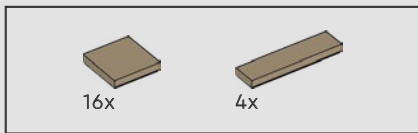

37

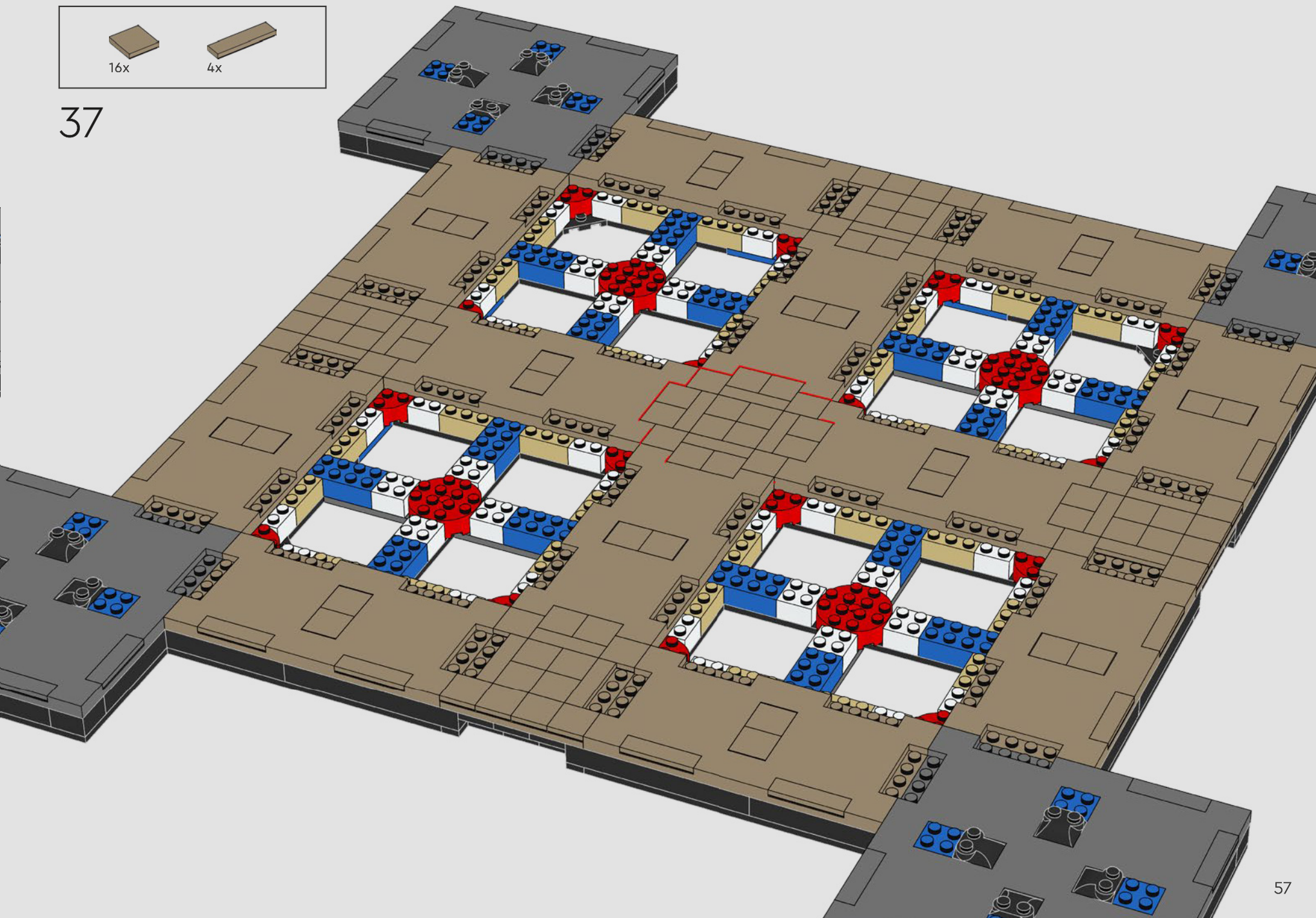



16x

38



16x

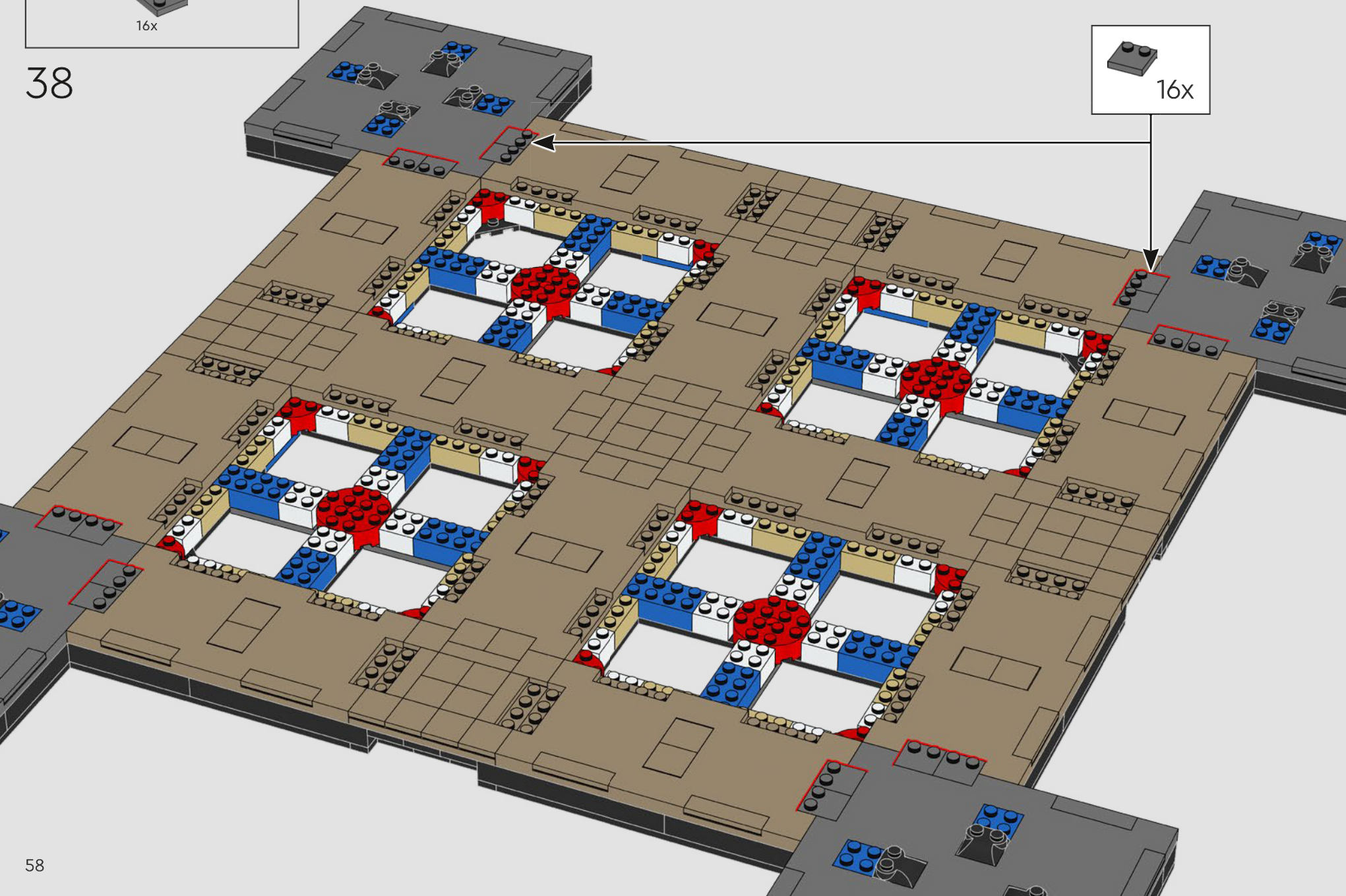

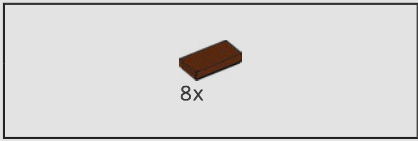

39

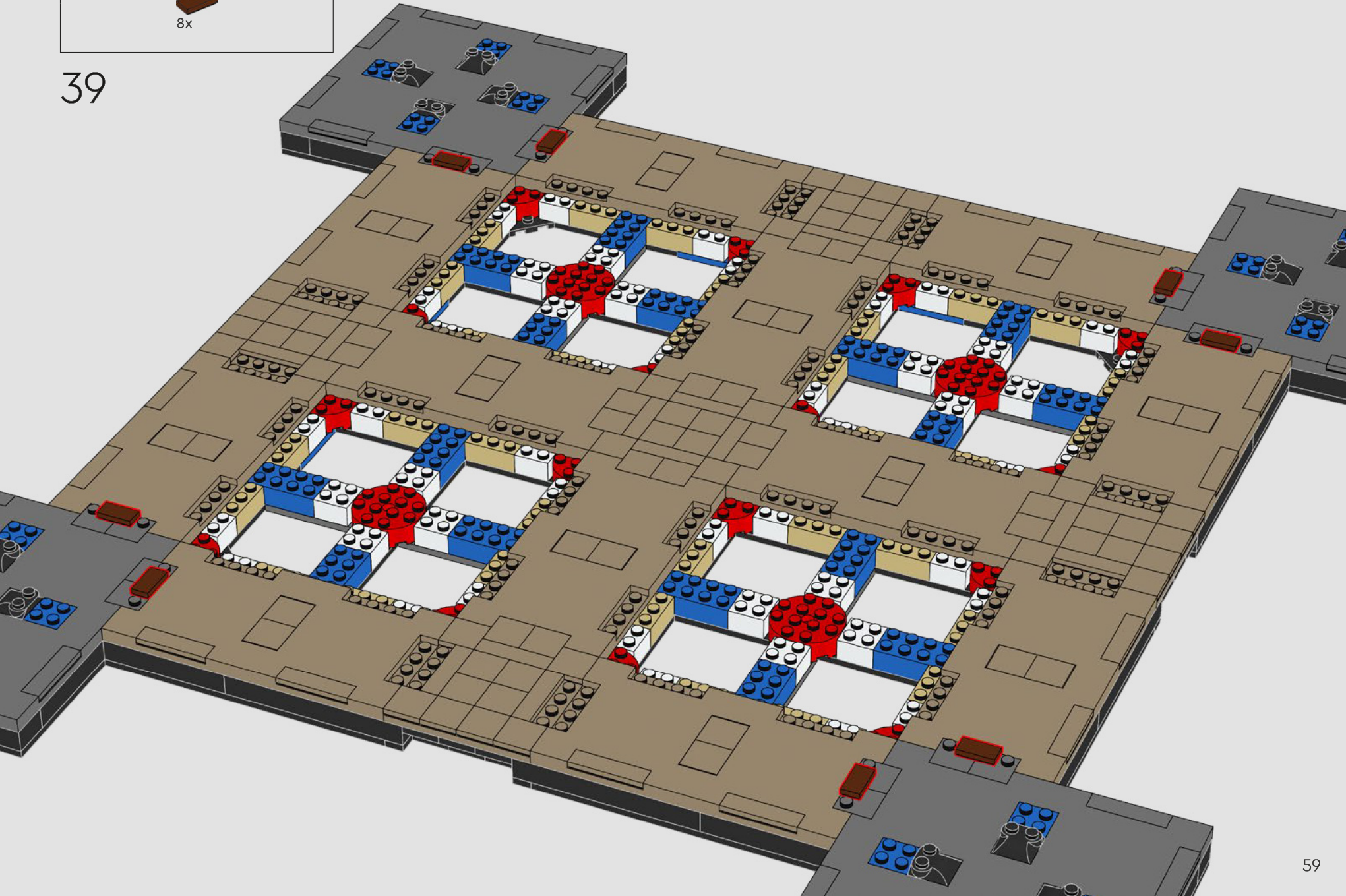

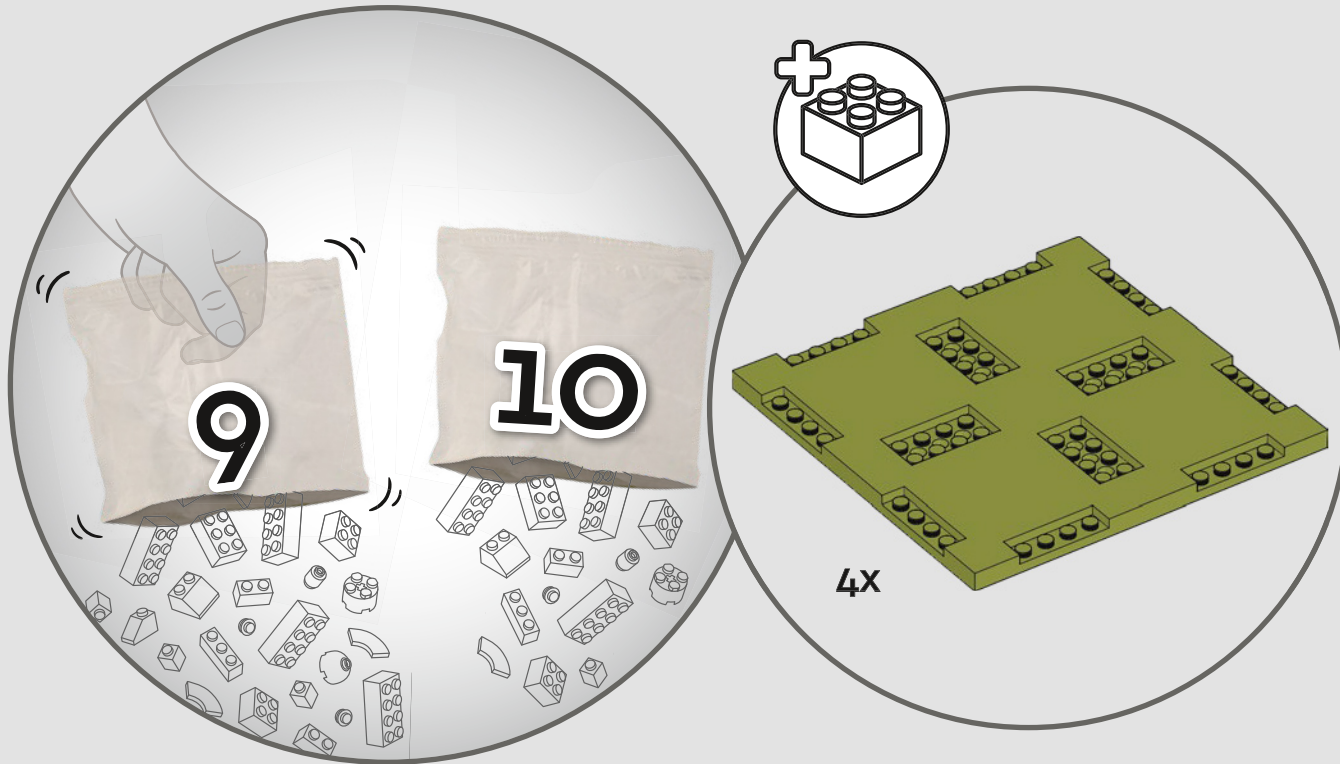

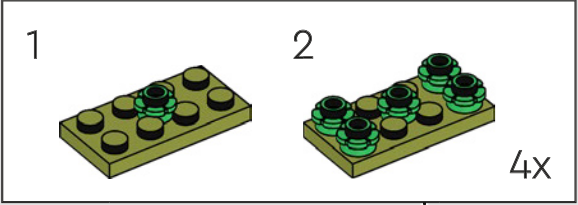
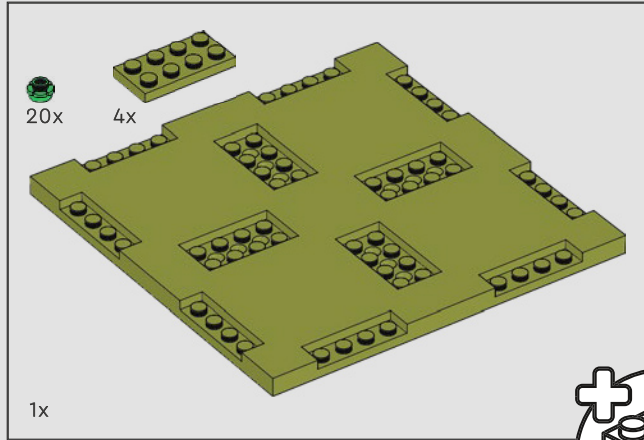
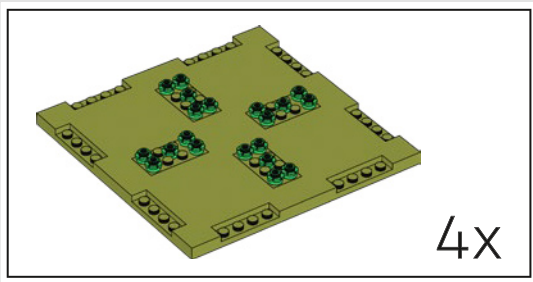

40

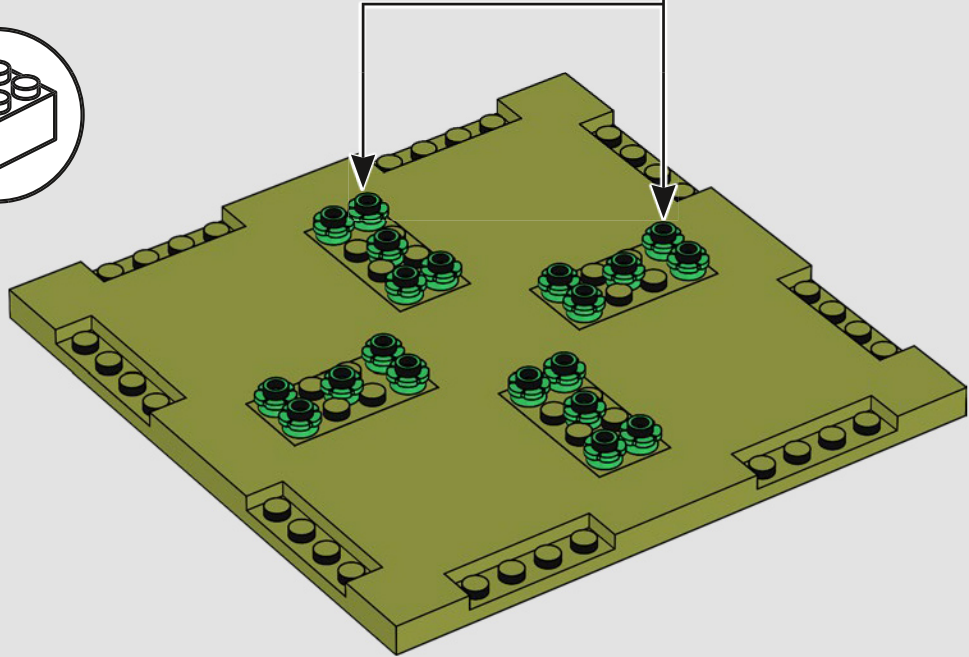
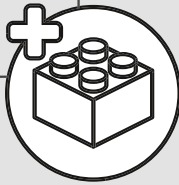

41

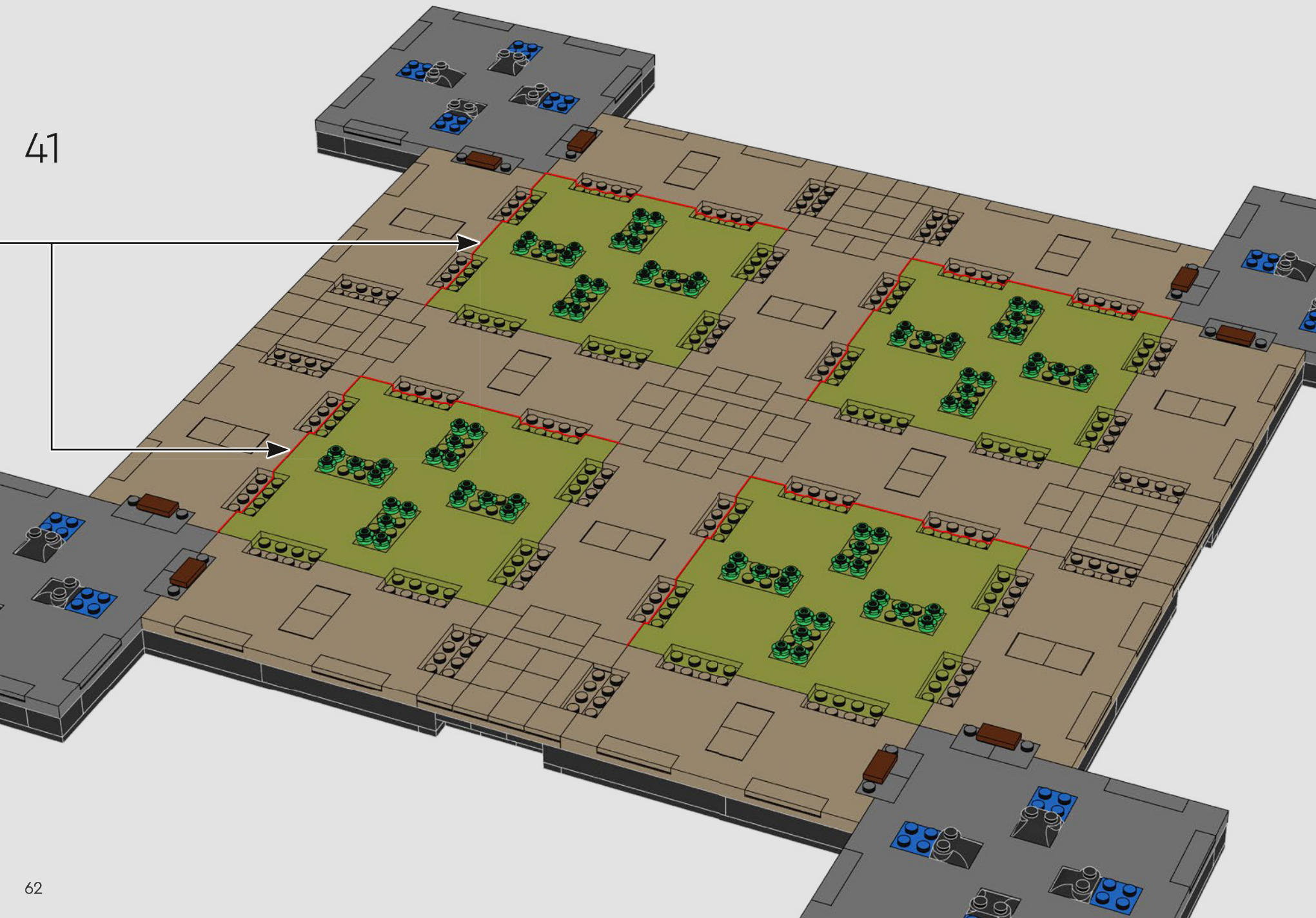

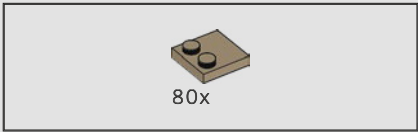

42





40x

43

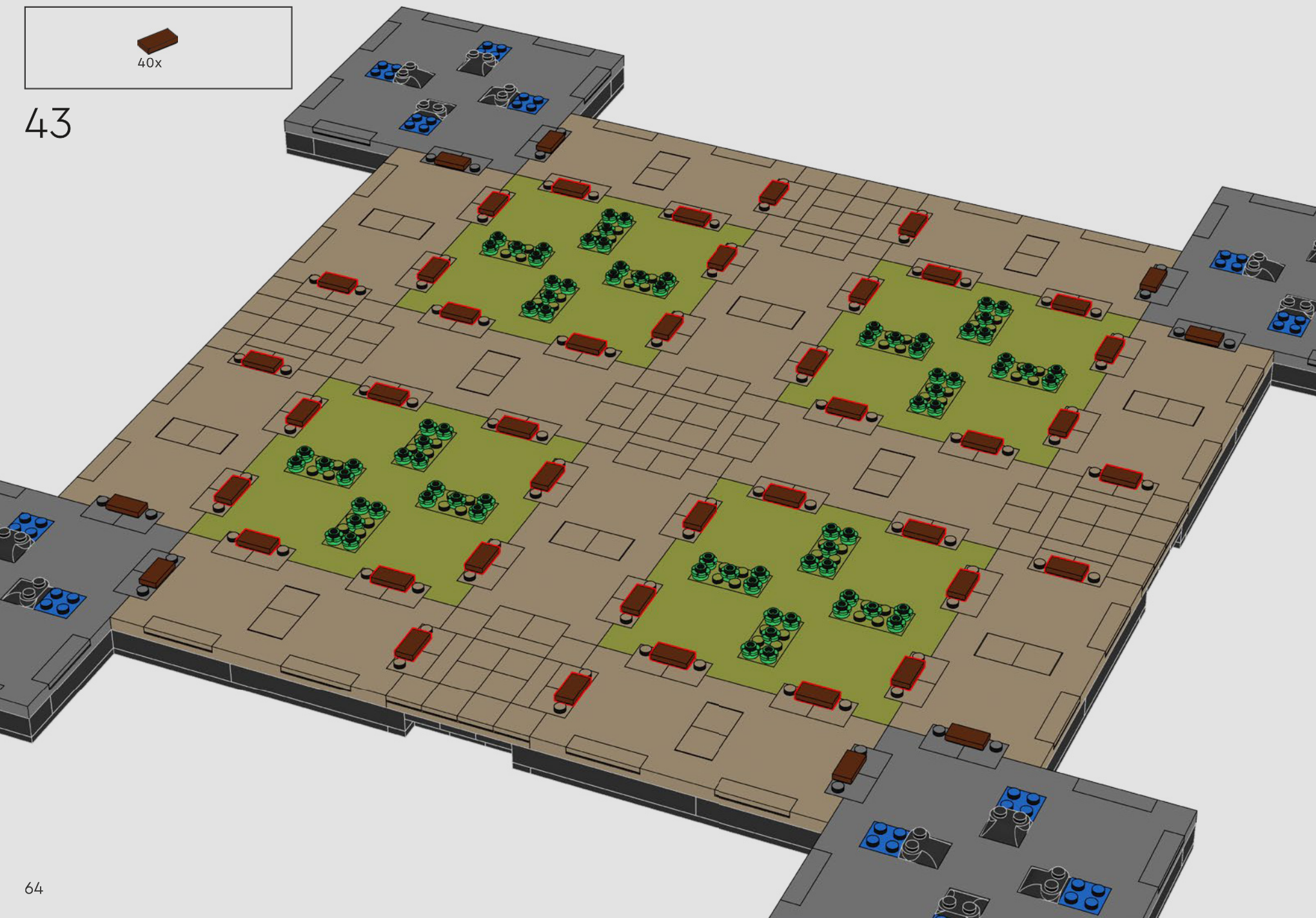

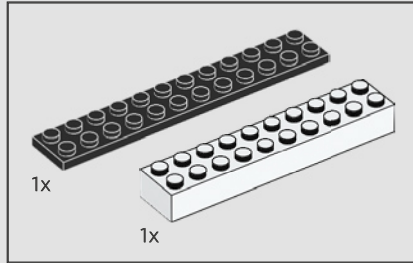
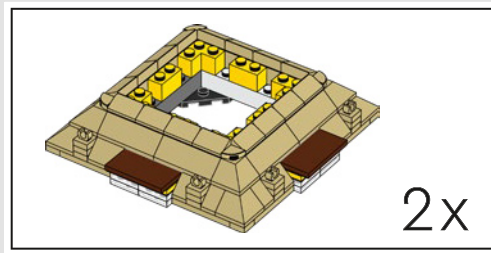

44

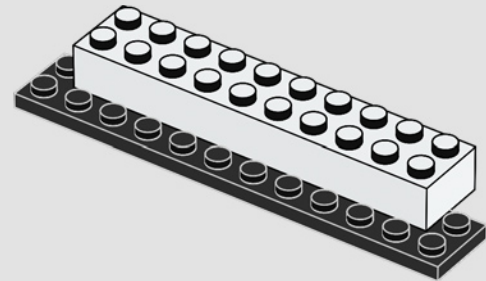

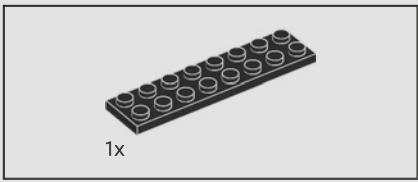

45

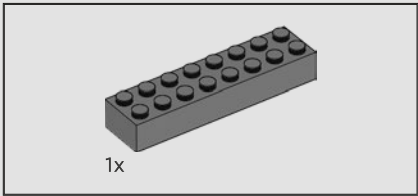
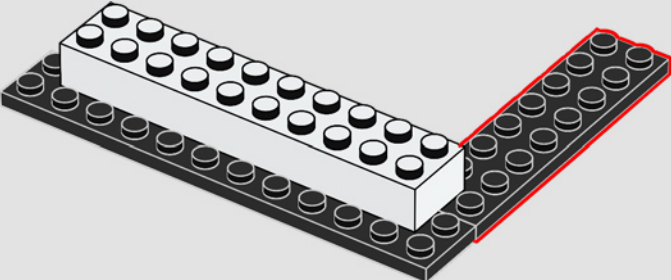

46

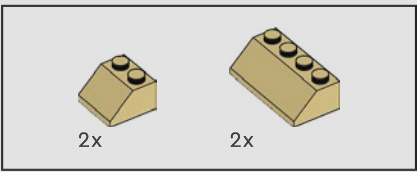
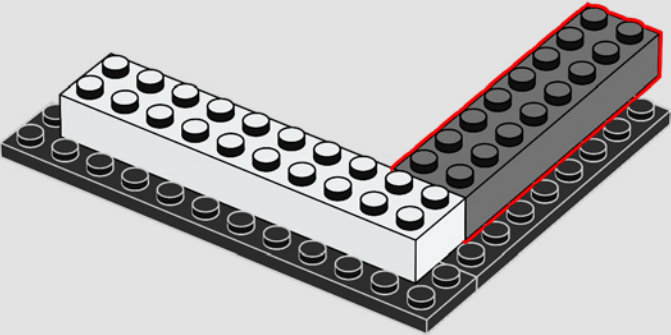

47

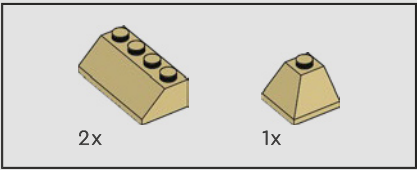
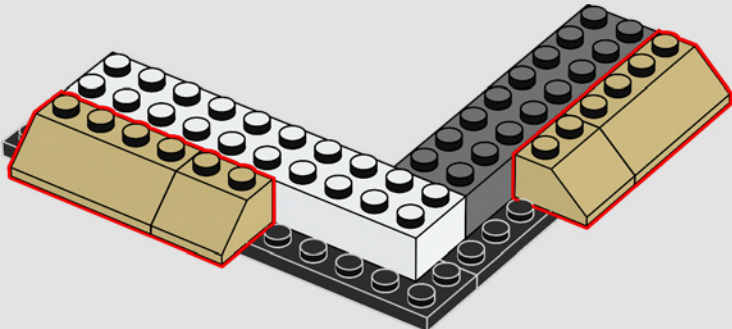

48

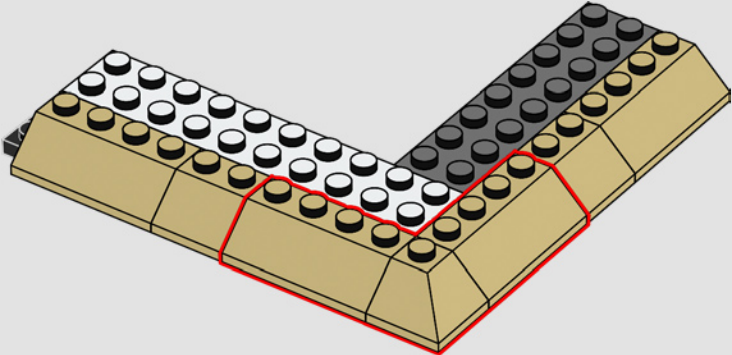

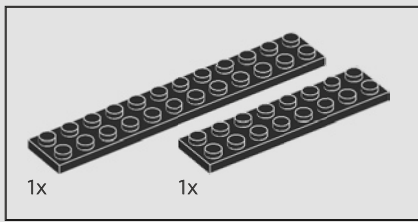

49

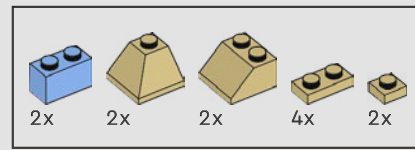
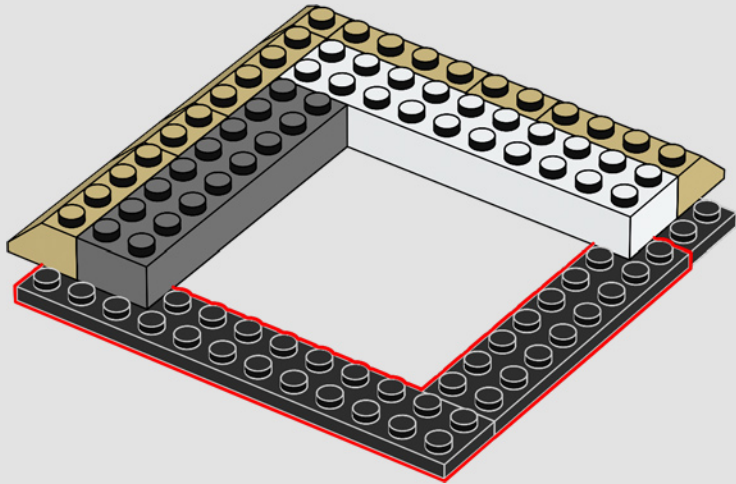

50

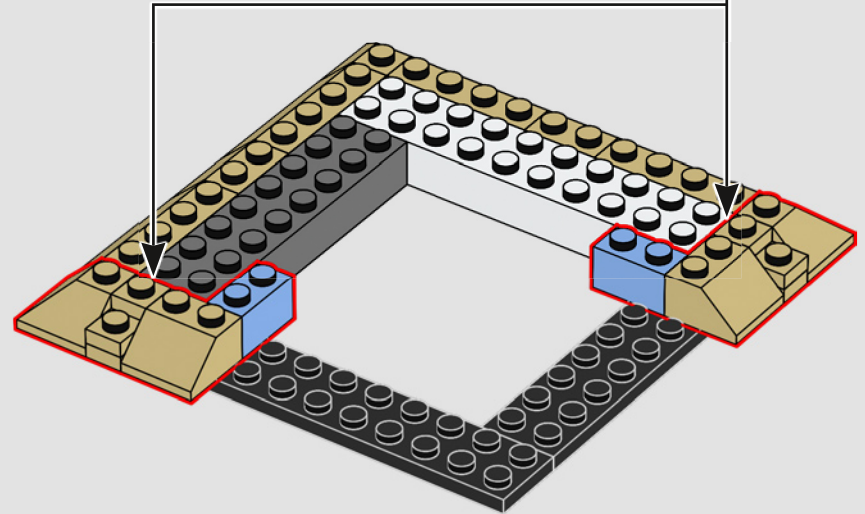
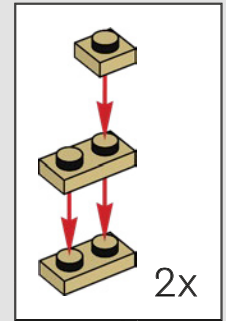

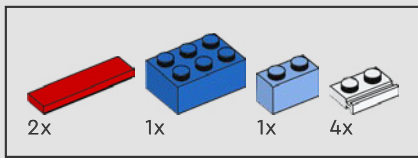

51

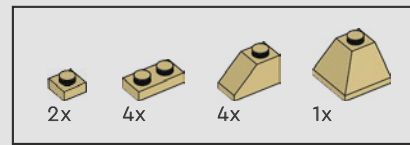
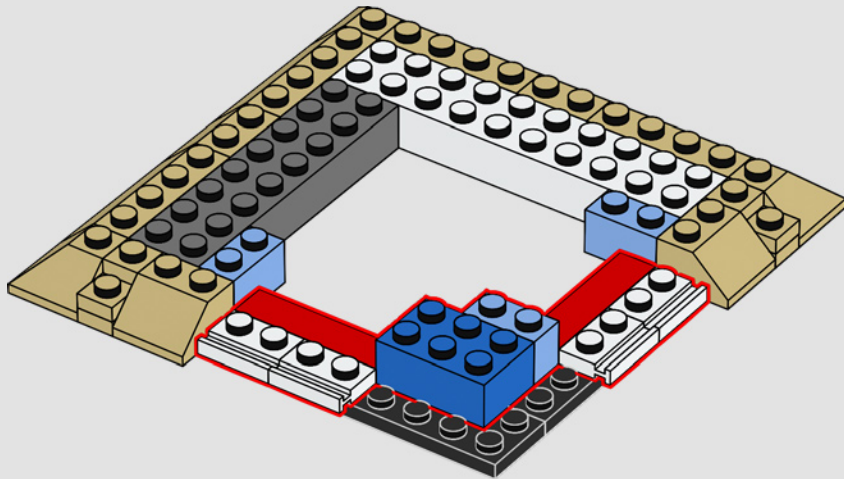

52

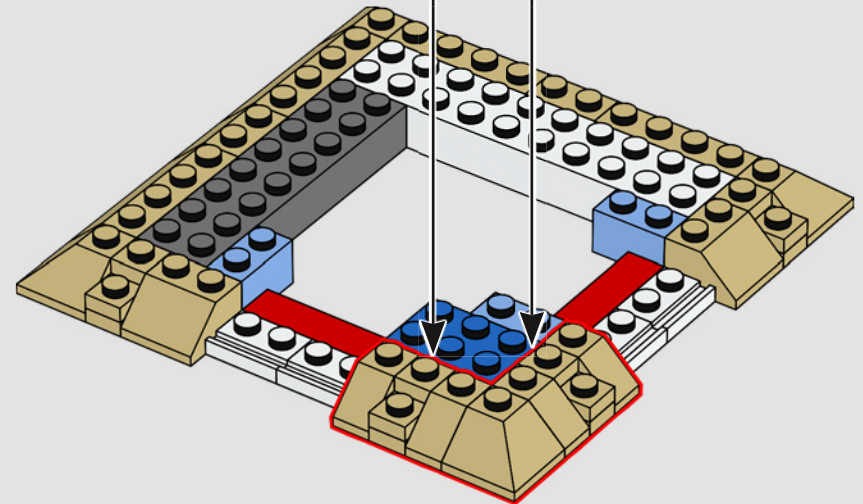
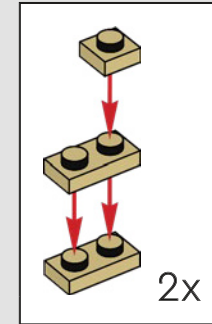

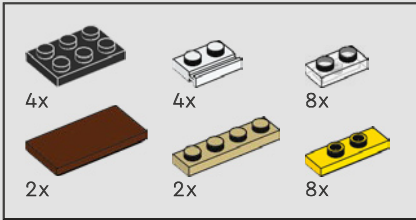
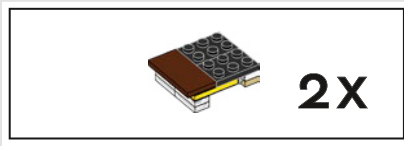

53

1

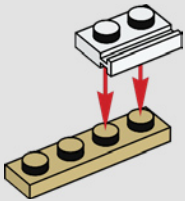

2

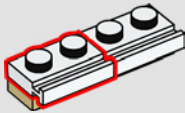

3

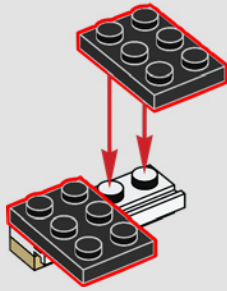

4

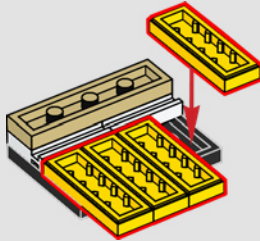

5

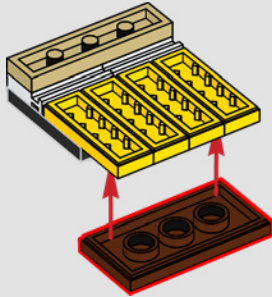

6

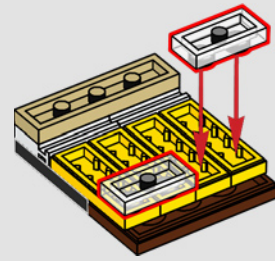

7

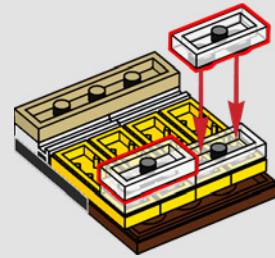

2x

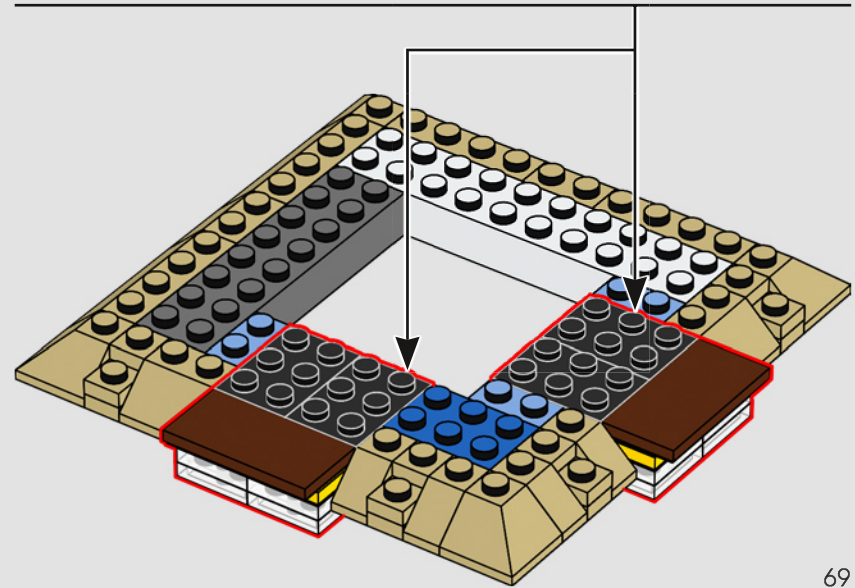

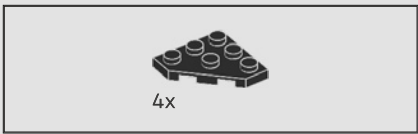

54

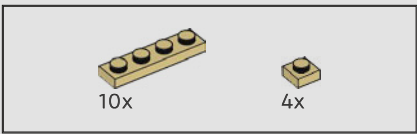
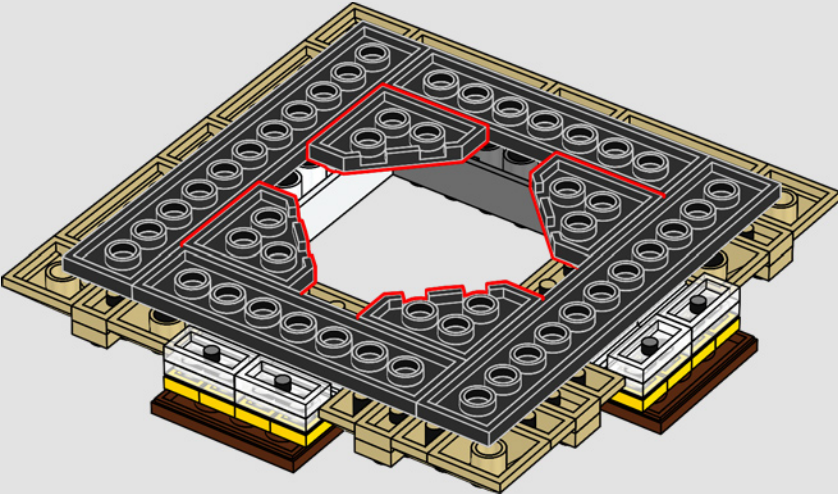

55

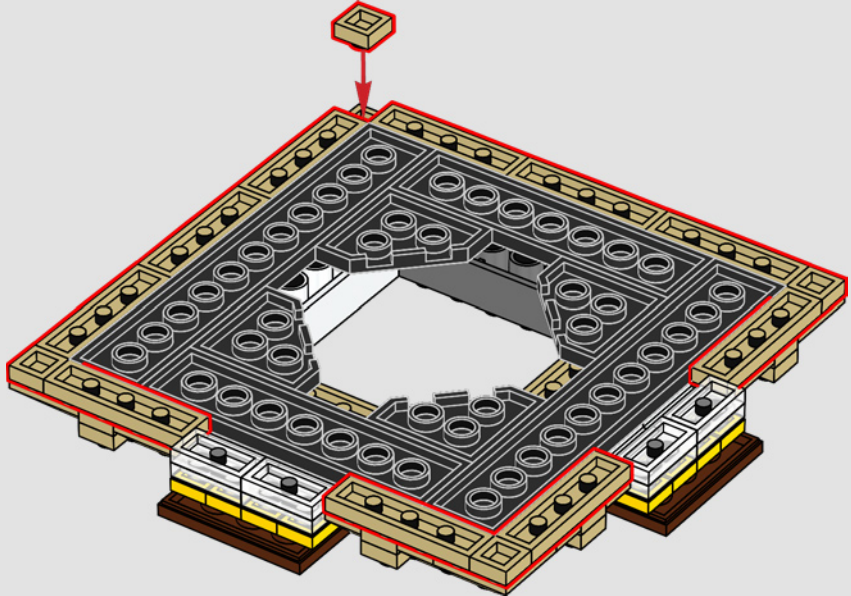

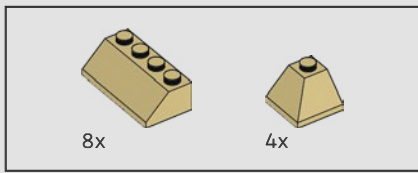

56

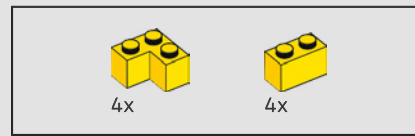
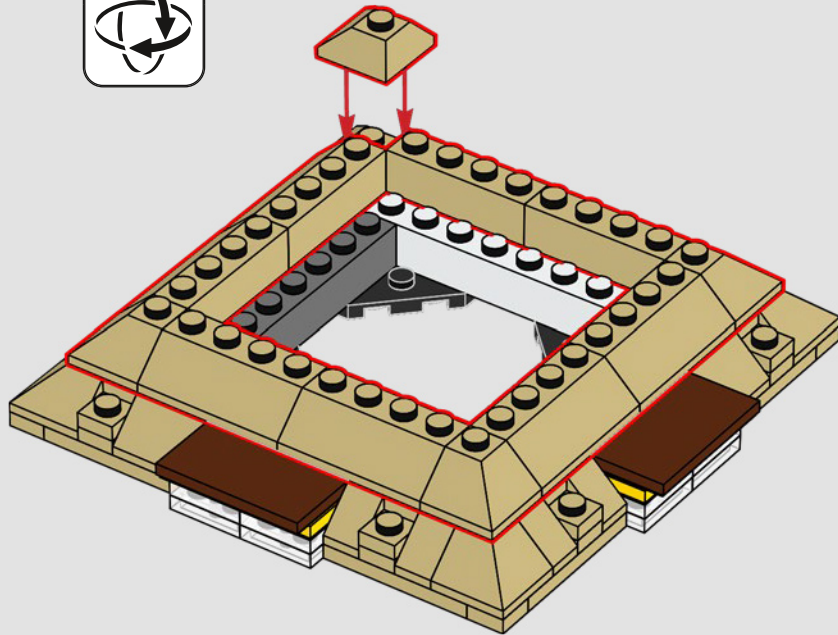

57

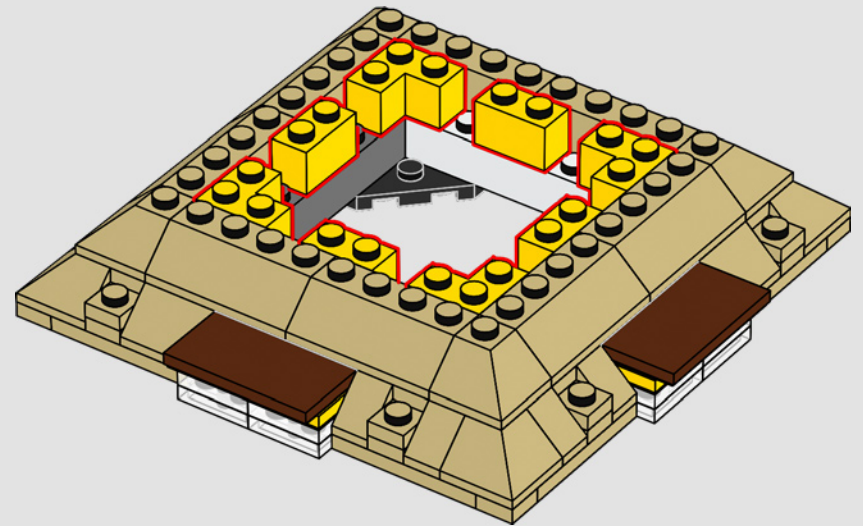



16x

58

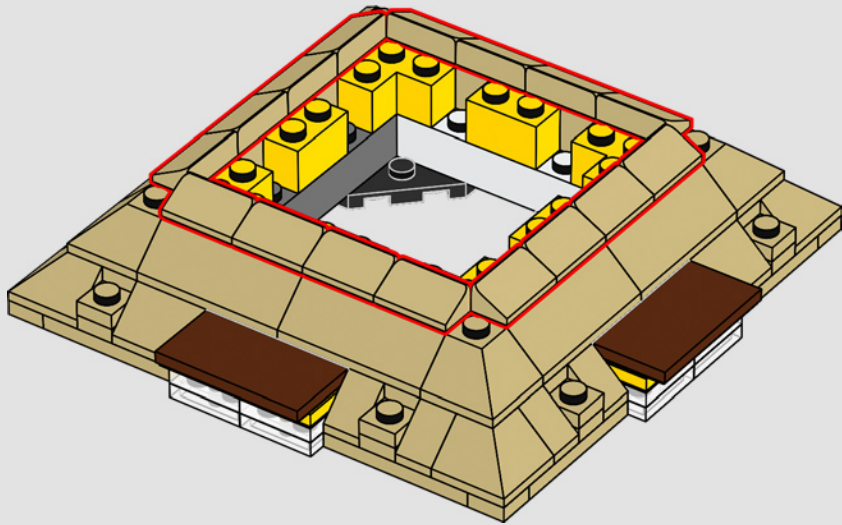

4x



4x

59

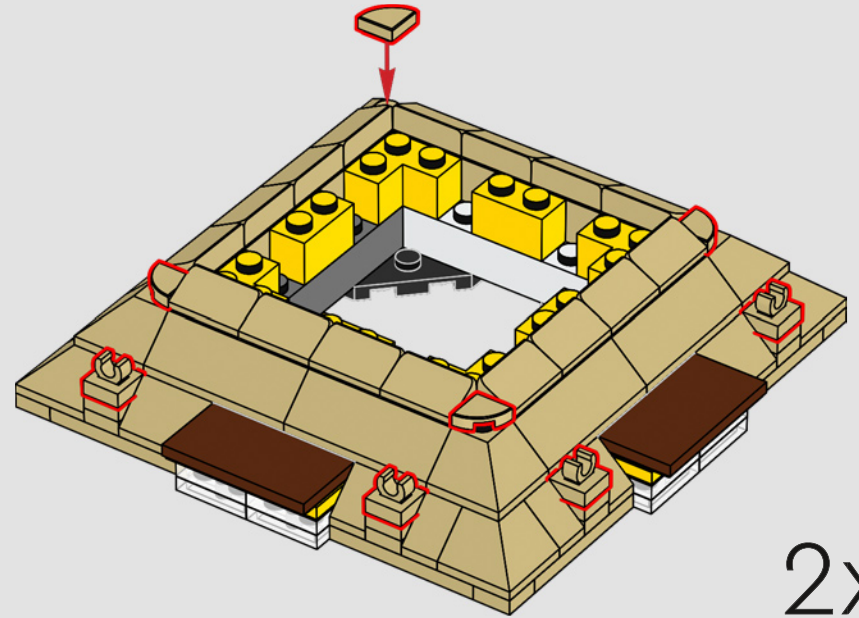

2x

60

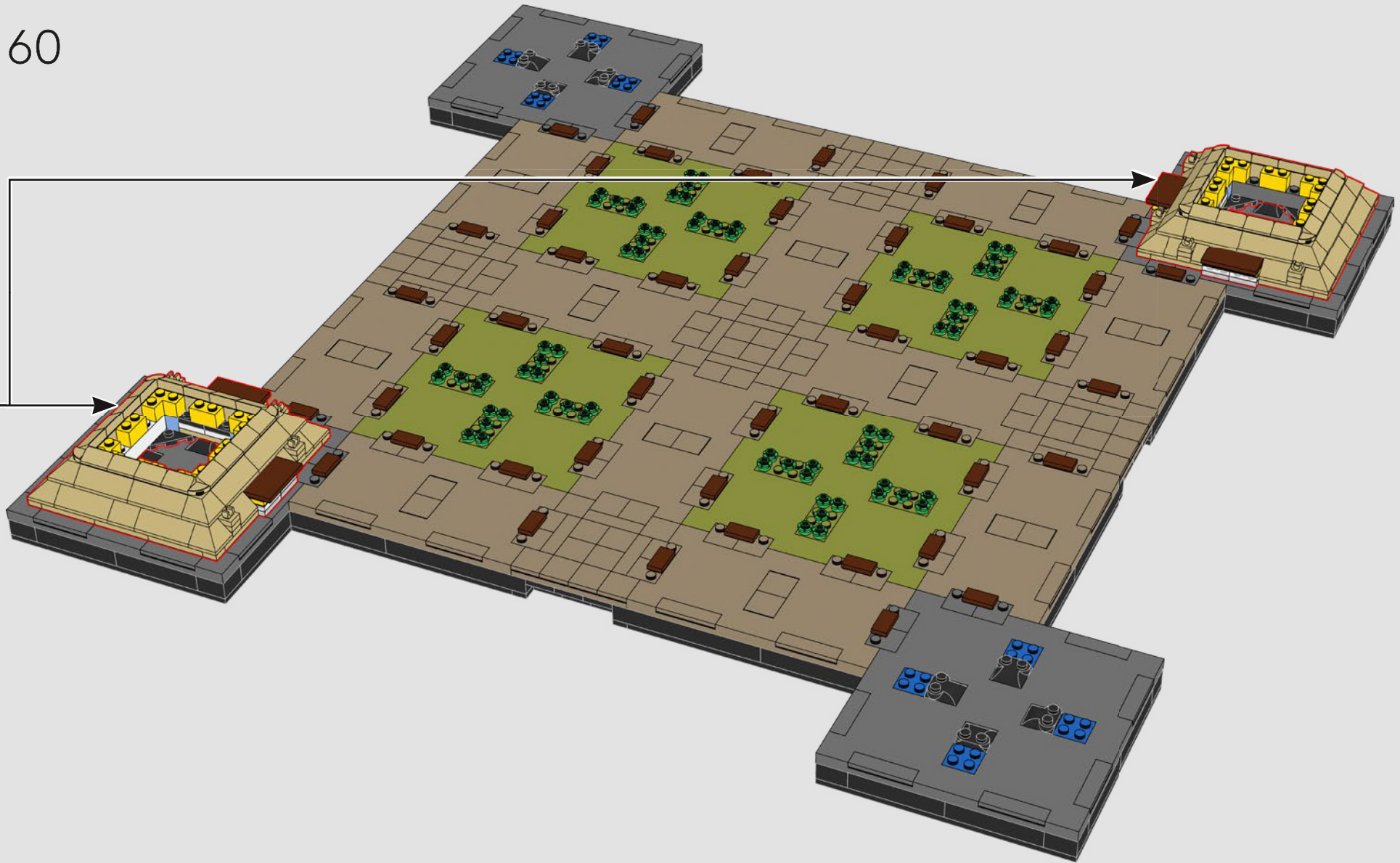

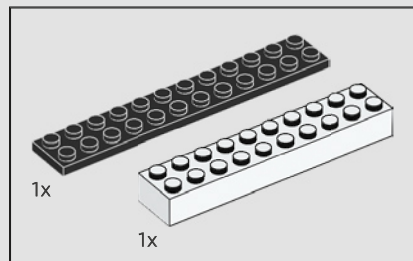
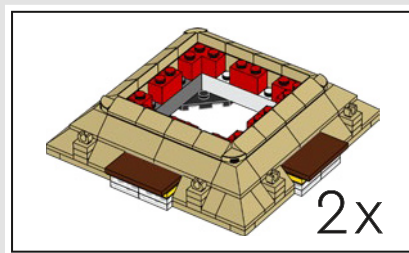

61

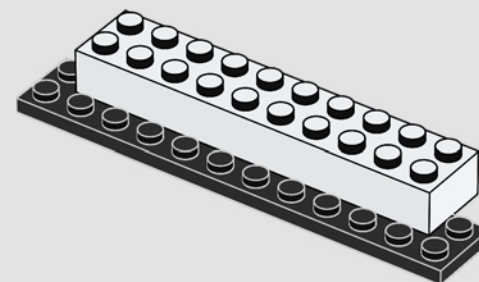

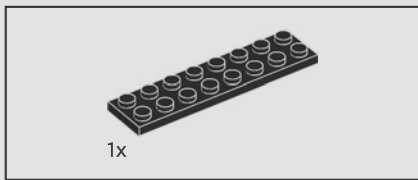

62

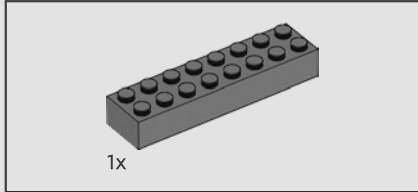
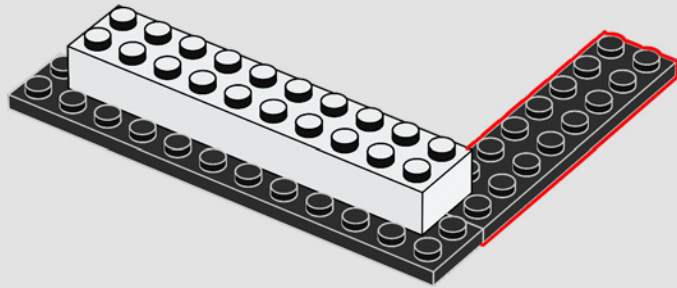

63

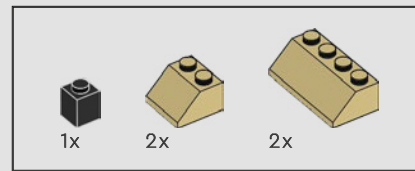
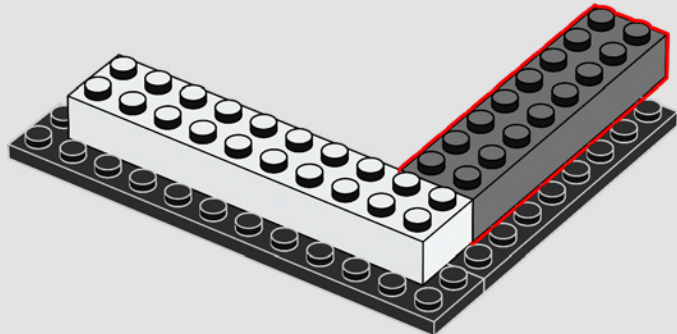

64

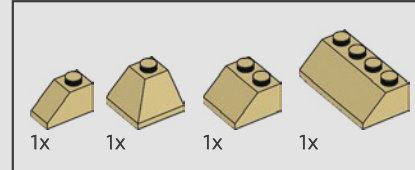
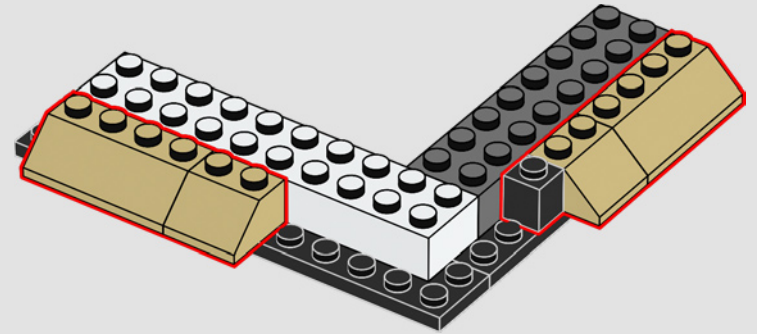

65

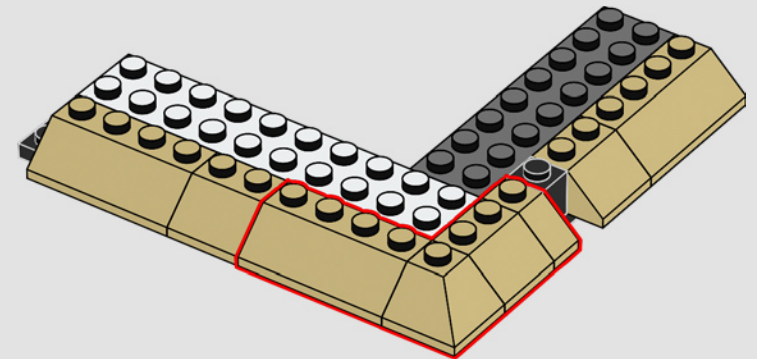

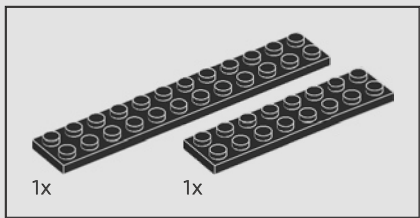

66

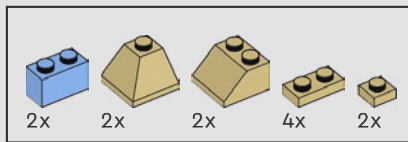
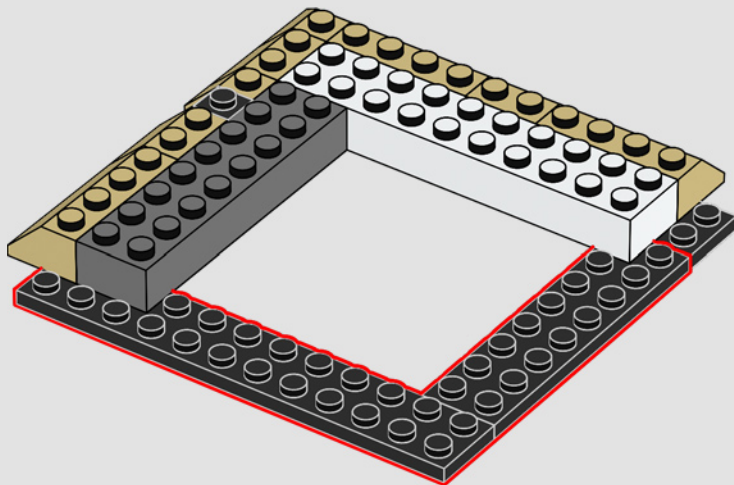

67

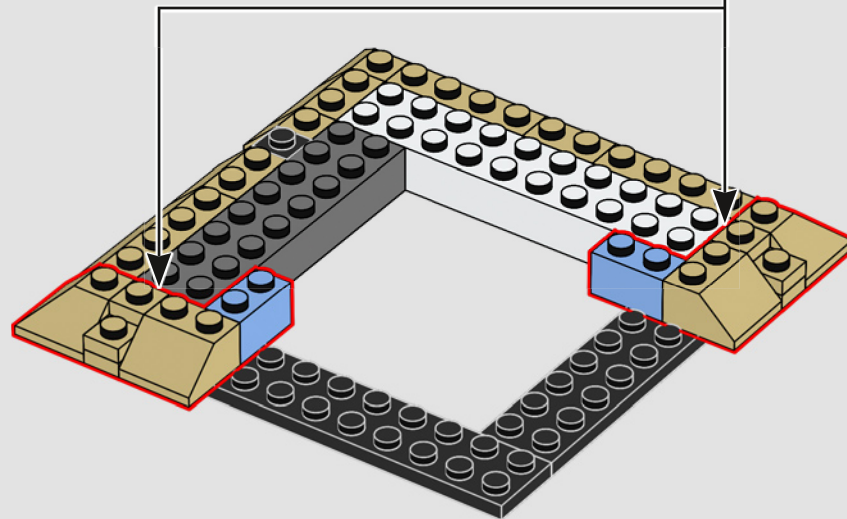
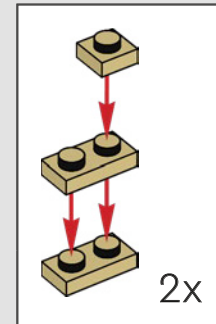

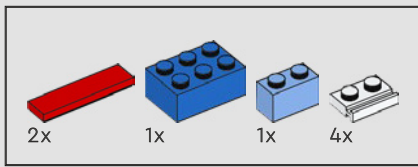

68

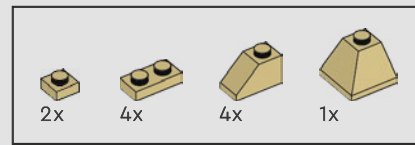
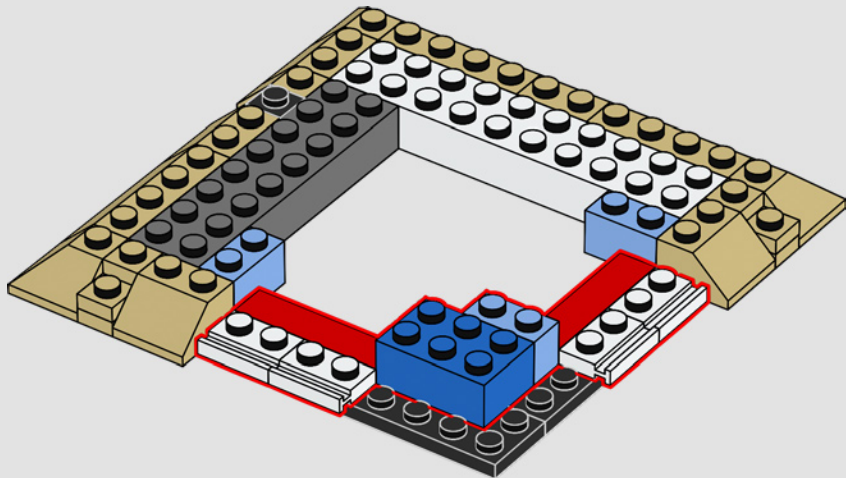

69

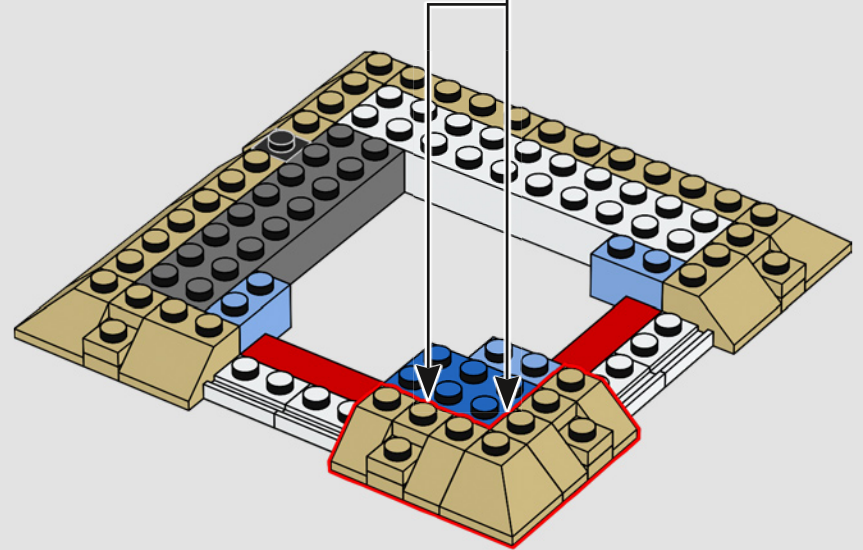
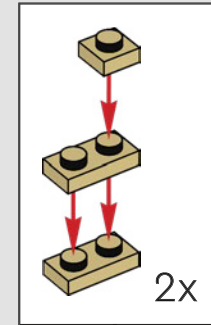

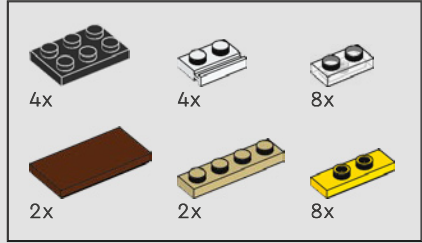

70

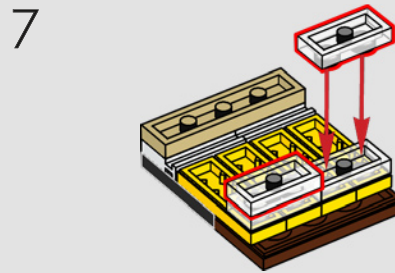
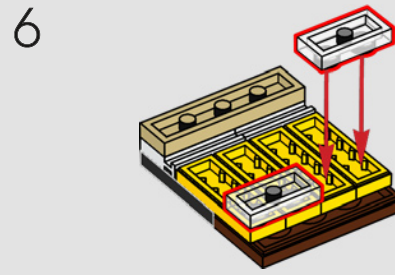
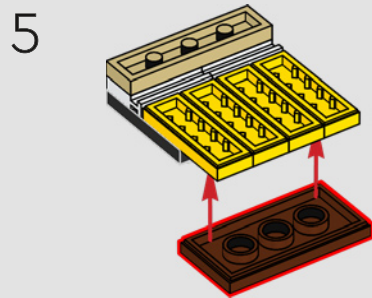
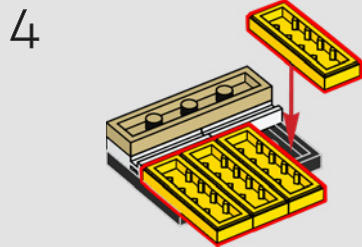
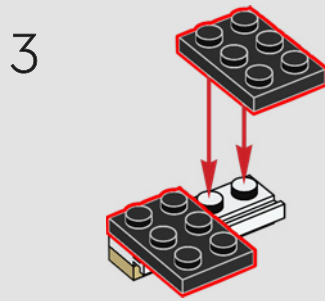
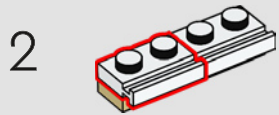
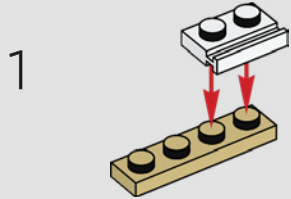

2x

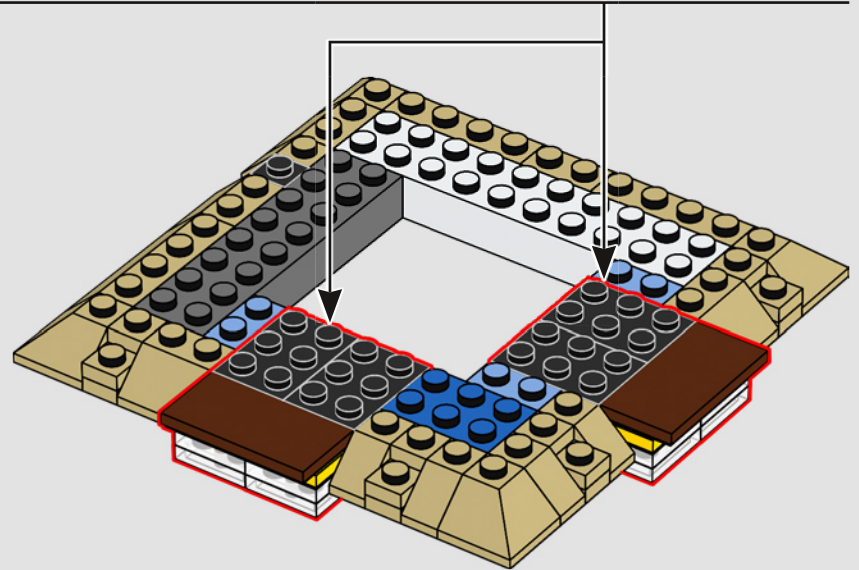

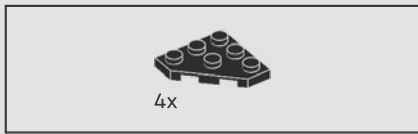

71

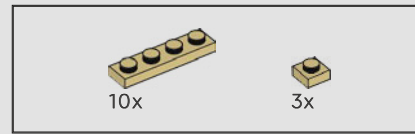
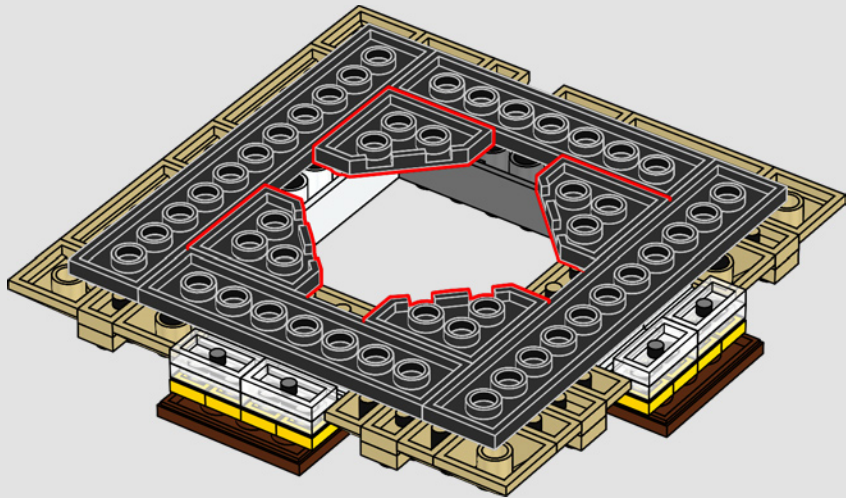

72

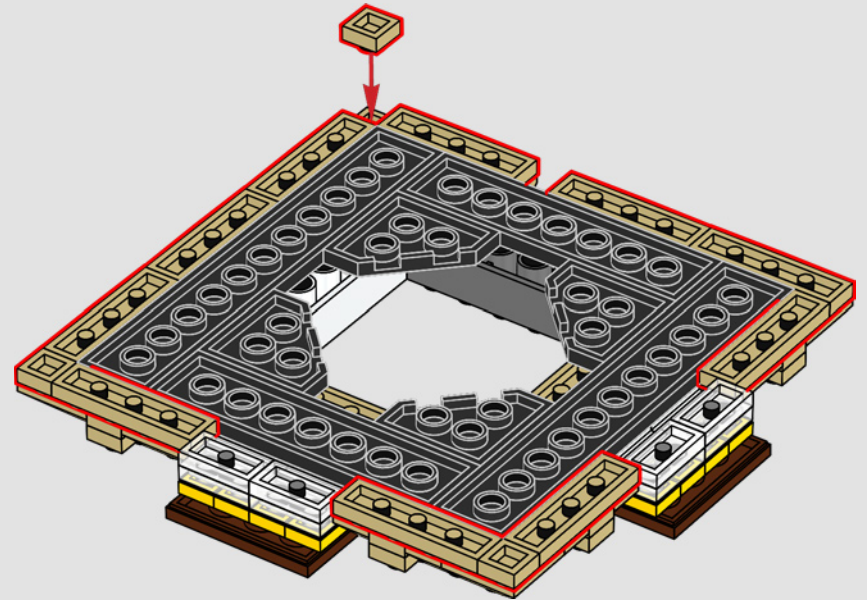

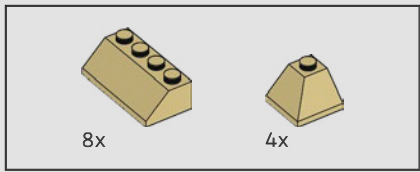

73

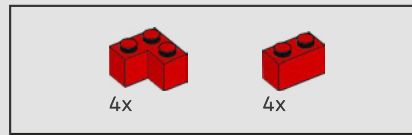
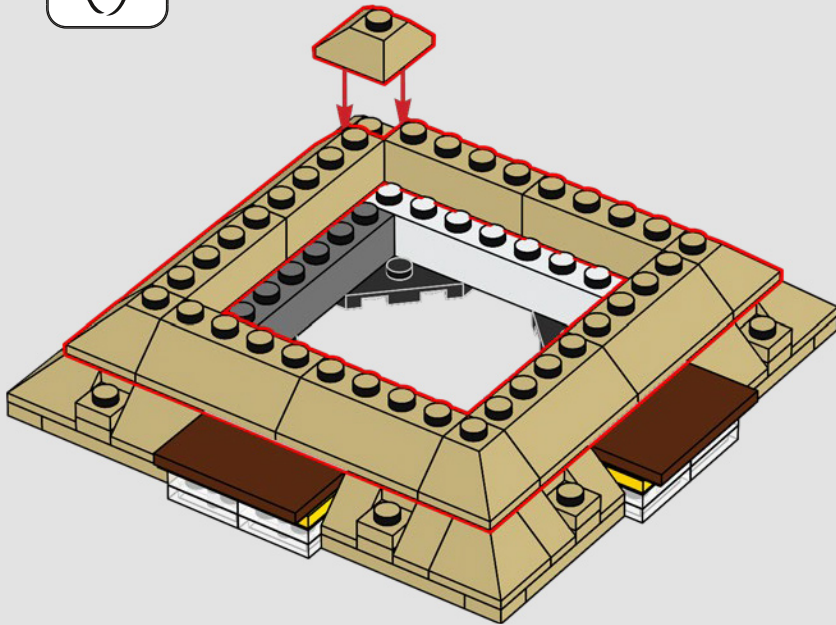

74

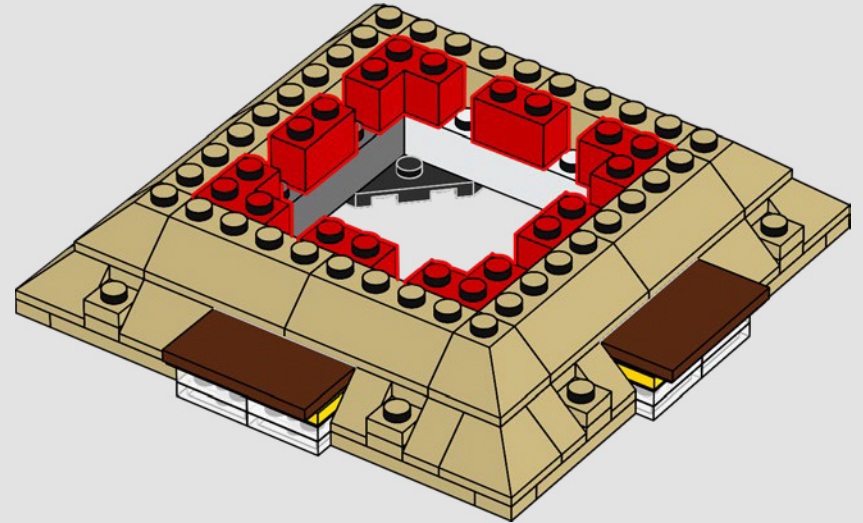

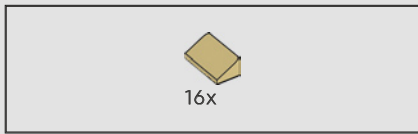

75

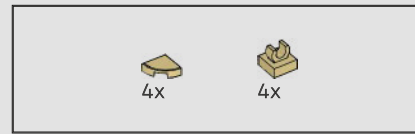
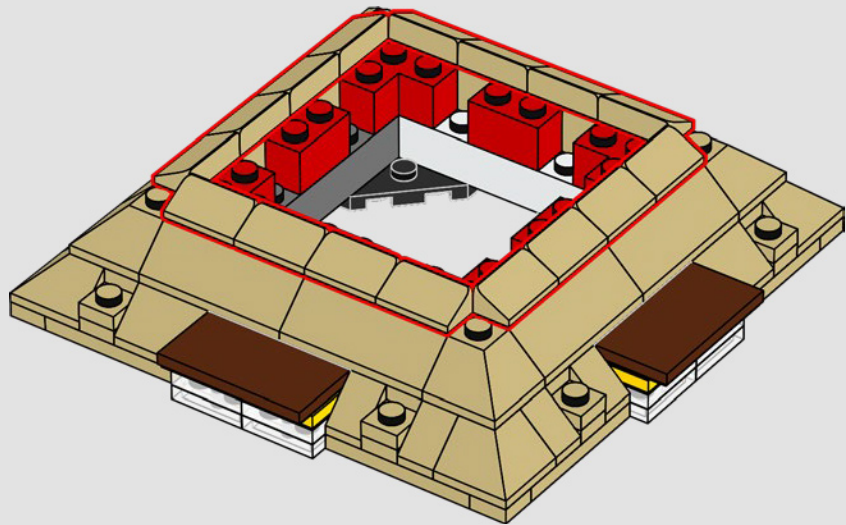

76

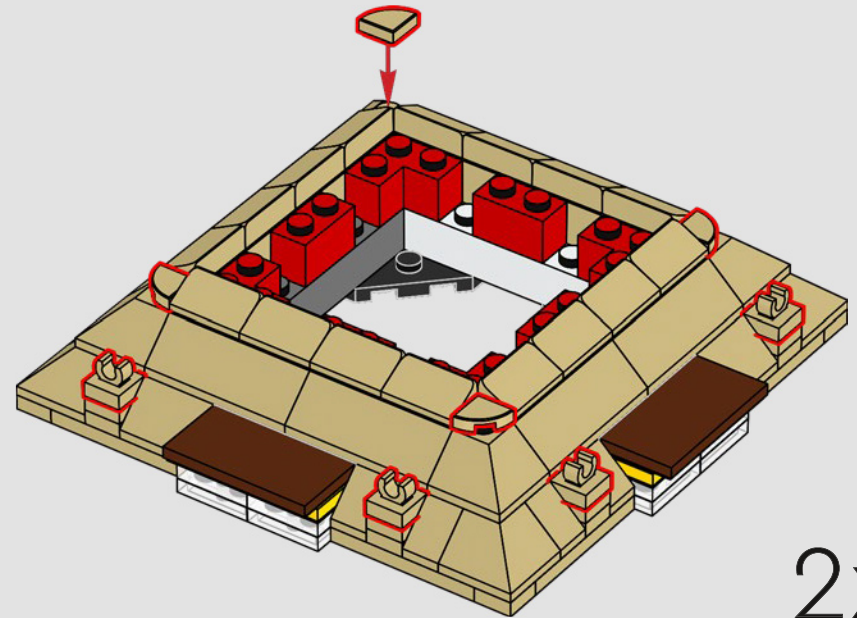

2x

77

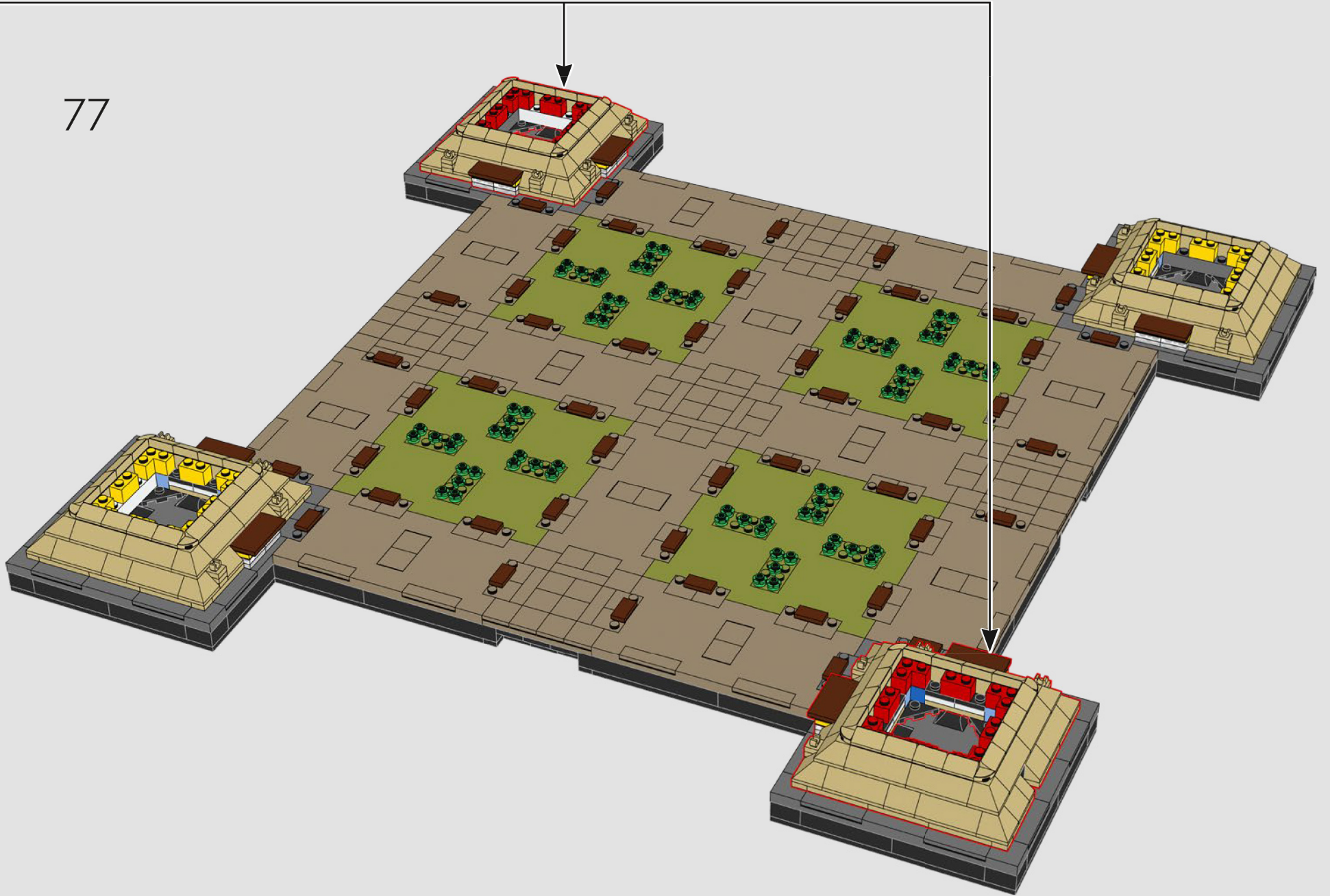



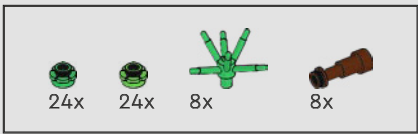

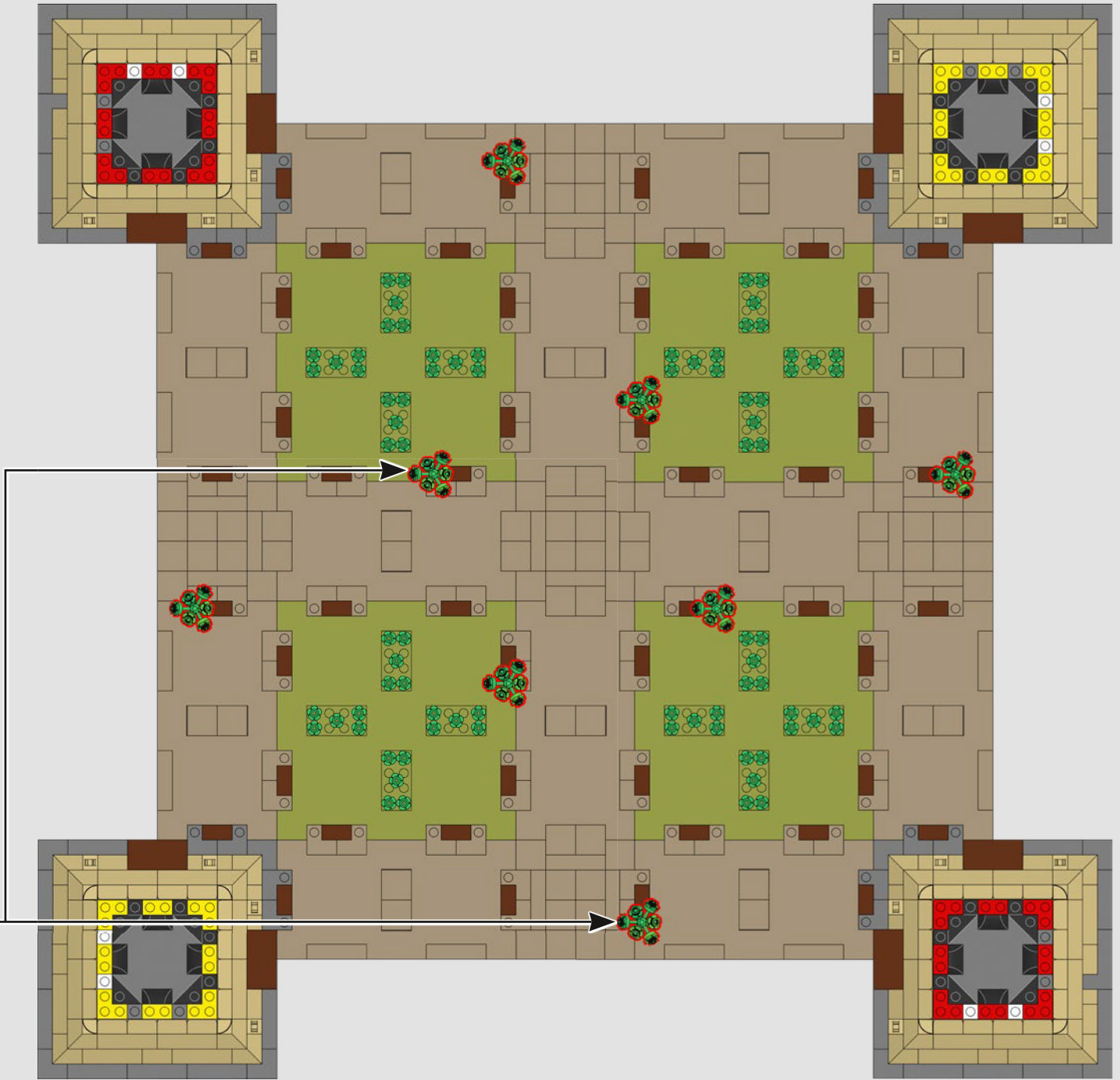
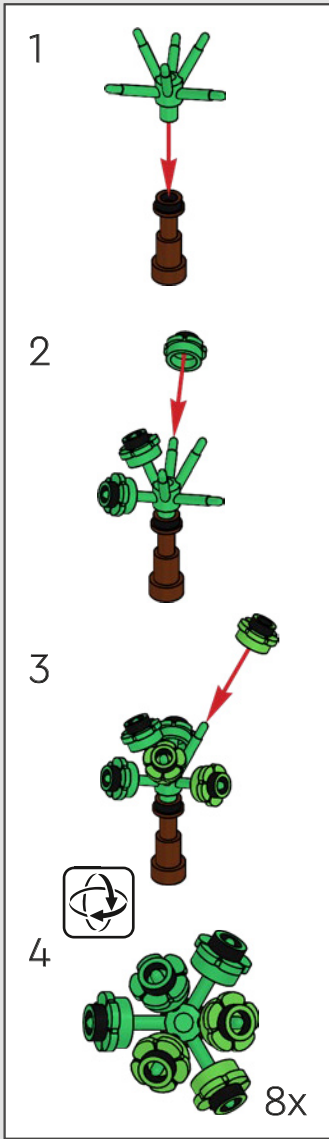

78



64x

79

- 1 
- 2 
 32x

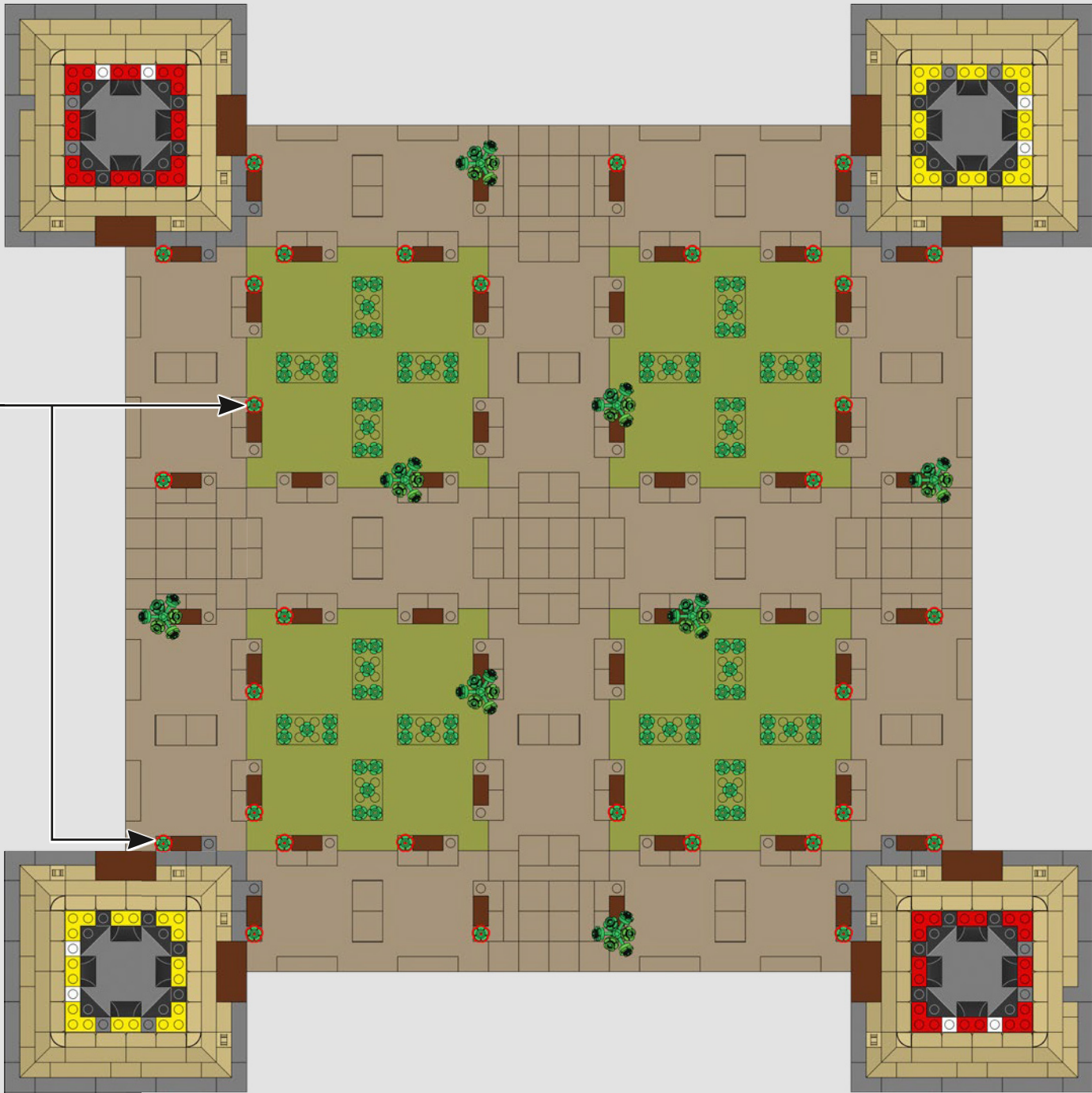



80

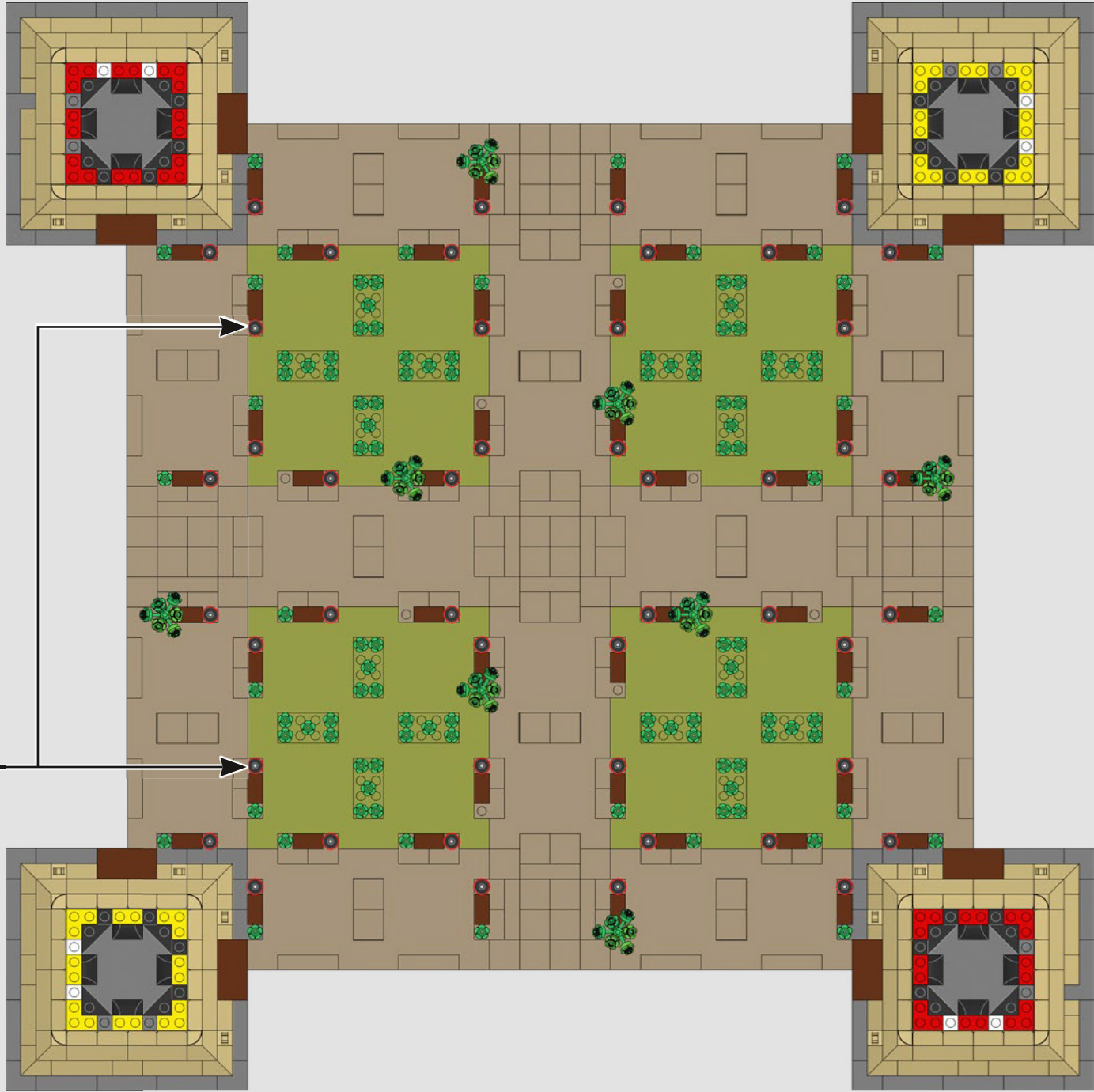
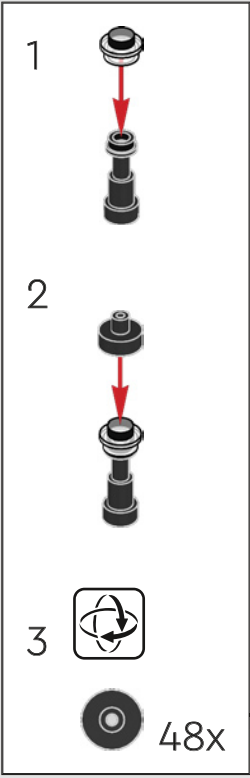

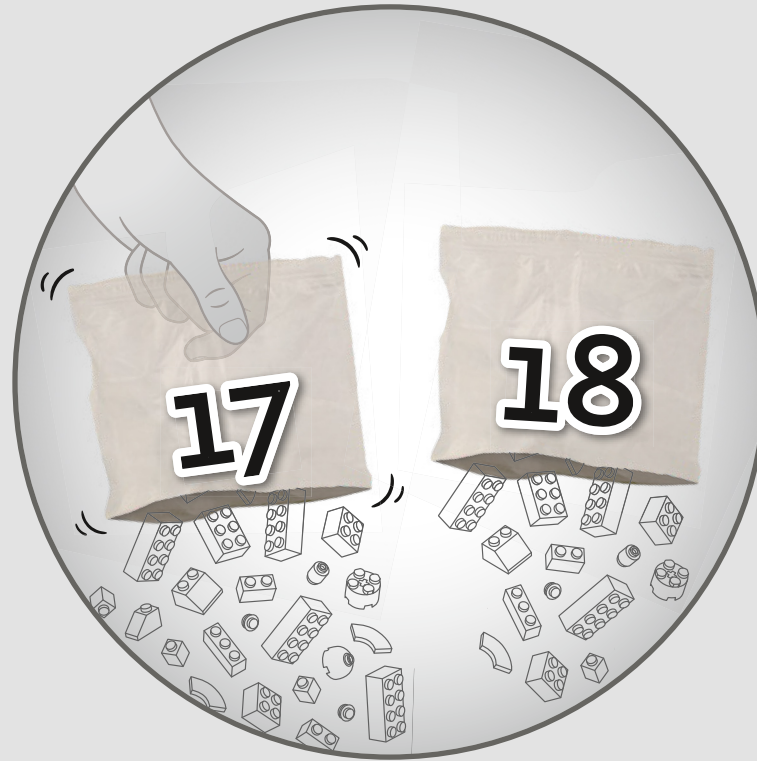

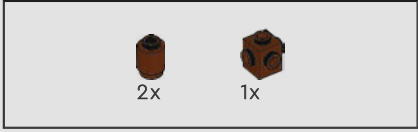
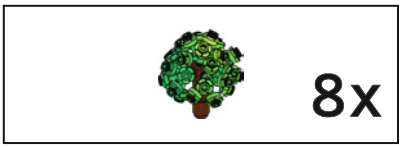

81

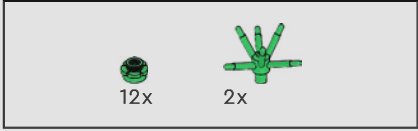

82

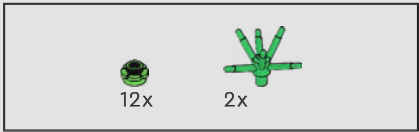
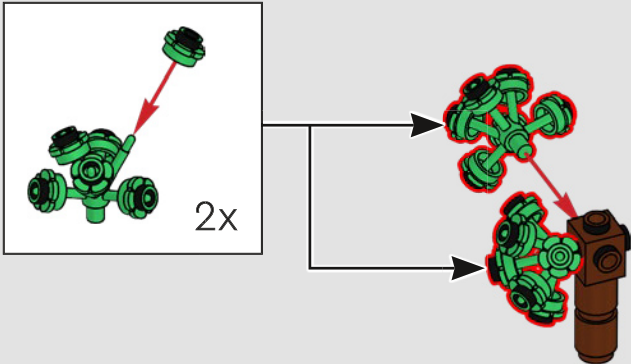

83

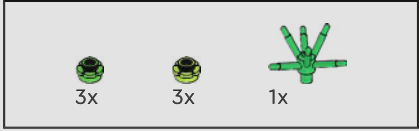
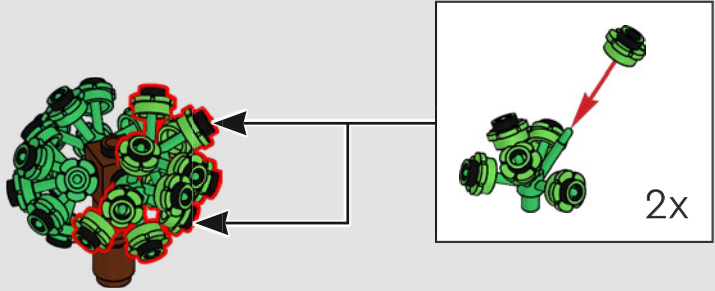

84

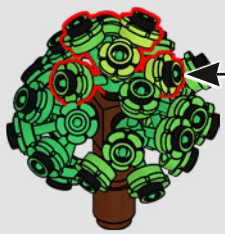
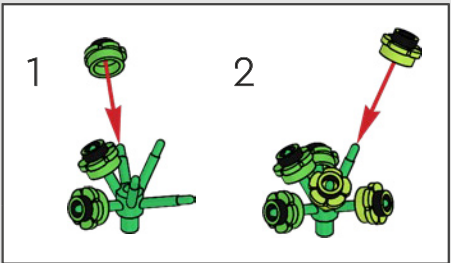

85

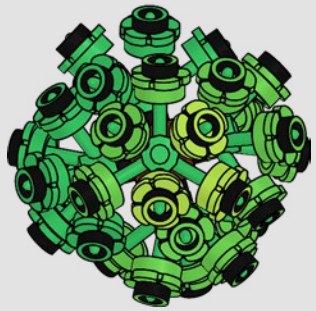

8x

86

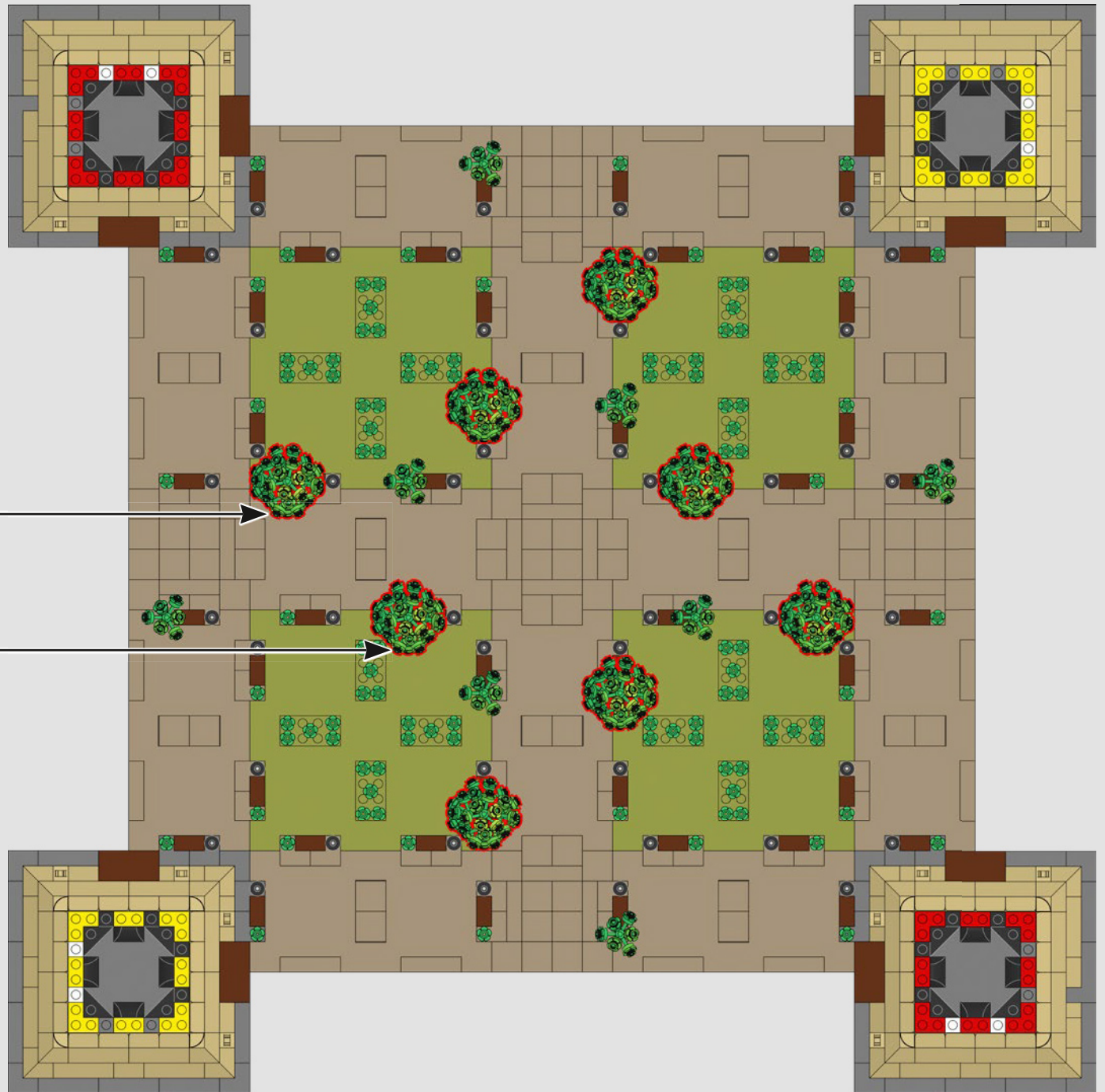



The base of the LEGO® model alludes to the tower's opening in the 19th century, with open, landscaped paths, enlivened with greenery, typical Parisian streetlights and benches.

La base du modèle LEGO® rappelle les aménagements de la tour au 19^e siècle, avec des allées ouvertes et paysagées, agrémentées de verdure, de lampadaires et de bancs typiquement parisiens.

Los senderos abiertos y bien cuidados, las áreas verdes, los faroles y las clásicas bancas parisinas que rodean la base del modelo LEGO® son referencias inequívocas al siglo XIX, la época en la que la torre abrió sus puertas.

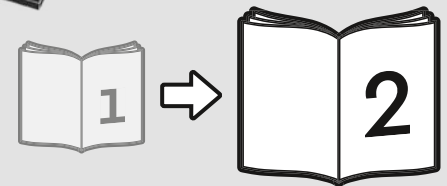



FEEDBACK AND WIN



FEEDBACK AND WIN

Your feedback will help shape the future development of this product series.

Please visit:

FEEDBACK UND GEWINNEN

Dein Feedback trägt zur Weiterentwicklung dieser Produktreihe bei.

Geh auf:

COMMENTEZ ET GAGNEZ

Vos commentaires nous aideront à concevoir les futurs produits de cette gamme.

Rendez-vous sur :

COMENTA Y GANA

Tu opinión nos ayudará a dar forma al desarrollo de esta serie de productos en el futuro.

Visita:

反馈有奖

您的反馈将有助于我们在今后改进本系列产品。

请访问：

[LEGO.com/productfeedback](https://www.lego.com/productfeedback)

By completing, you will automatically enter a drawing to win a LEGO® set.

Terms & Conditions apply.

Durch Ausfüllen nimmst du automatisch an der Verlosung eines LEGO® Preises teil.

Es gelten die Teilnahmebedingungen.

En envoyant vos commentaires, vous serez automatiquement inscrit(e) à un tirage au sort qui vous permettra de remporter un prix LEGO®.

Offre soumise à conditions.

Al contestar, participarás automáticamente en el sorteo y podrás ganar un set LEGO®.

Sujeto a Términos y Condiciones.

完成我们的反馈调查，即可自动进入抽奖环节，赢取乐高®套装。

适用《条款和条件》。

La tour
Eiffel

Torre
Eiffel

