



21327

SYSTEM

Booklet available in English on
Livret disponible en français sur
Folleto disponible en español en



Creative writing and classic design

Indulge in your passions for the art of creative writing and classic design as you build, then find that special place for your LEGO® typewriter. Thomas Kirk Kristiansen, Chairman of the LEGO Group and representative of the fourth generation of the owner family, saw this set as a fun opportunity to write a letter to the dedicated LEGO Ideas fans – you! The letter is printed in 43 different languages in the enclosed booklet. Find one you would like to display in your LEGO typewriter, and carefully tear it from the booklet.

Écriture créative et conception classique

Comblez votre amour pour l'écriture créative et la conception classique en construisant ce modèle, puis trouvez une place toute spéciale pour votre machine à écrire LEGO®. Thomas Kirk Kristiansen, président du Groupe LEGO et représentant de la quatrième génération de la famille propriétaire de l'entreprise, a vu dans cet ensemble une occasion amusante d'écrire une lettre aux amateurs dévoués de LEGO Ideas comme vous ! La lettre est imprimée en 43 langues différentes dans le livret ci-joint. Choisissez la version que vous désirez exposer sur votre machine à écrire LEGO et détachez-la délicatement du livret.

Escritura creativa diseño clásico

Vive con todos los sentidos tu pasión por el arte de la escritura creativa y el diseño clásico a medida que construyes, y luego encuentra un lugar especial para tu máquina de escribir LEGO®. Thomas Kirk Kristiansen, presidente de The LEGO Group y representante de la cuarta generación de la familia propietaria, vio este set como una divertida oportunidad para escribir una carta al más dedicado de los fans de LEGO Ideas: ¡tú! La carta está impresa en 43 idiomas diferentes en el folleto incluido. Encuentra una que quieras exponer en tu máquina de escribir LEGO, y luego despréndela cuidadosamente del folleto.

« J'espère que cette machine à écrire classique vous rappellera de bons souvenirs – ou vous donnera l'impression d'être un journaliste ou un auteur à succès des années 1950. »

Thomas Kirk Kristiansen

“ Espero que esta clásica máquina de escribir te traiga entrañables recuerdos o que te haga sentir como un reportero/autor de best sellers de los años 50. ”

Thomas Kirk Kristiansen

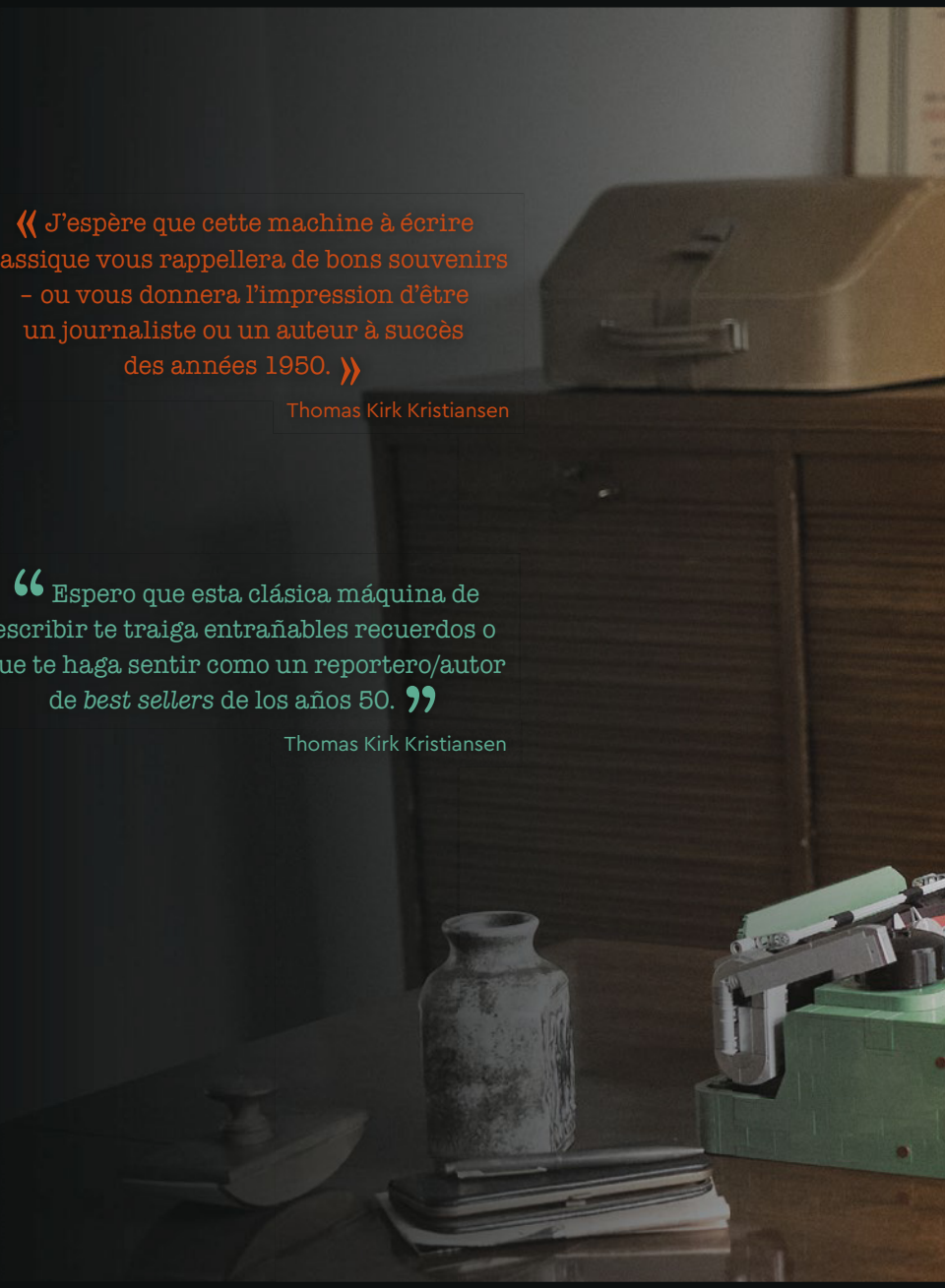

“ I hope this classic typewriter
will bring back fond memories
– or make you feel like a cool 1950s
reporter/bestselling author. ”

Thomas Kirk Kristiansen



An epitome of the modern revolution

The classic typewriter was an invaluable instrument for businesses all over the world, as it was for Ole Kirk Kristiansen (shown here) and his life's work in the LEGO Group. Iconic authors created some of the world's most beloved modern literature on theirs. Investigative reporters put their reputation at stake to unravel the truth, and friends and loved ones poured their hearts out over the keys. It is an icon of the modern revolution.

Invented in 1874, the first commercial typewriters took a decade to break into mainstream culture. For almost a hundred years, they were found in most offices and homes, replacing handwritten records and setting new standards for correspondence. Some adult fans may remember taking touch typing lessons in school when a high words-per-minute count was considered a coveted skill on their resumé. The smell of the oiled inner metal workings, the gratifying feeling of a perfect, typo-free document, or getting your hands smudged with ink when changing the ribbon.

Younger fans have been raised with computers and electronic keyboard typing as second nature. While functionality has developed significantly, the keyboard layout itself still remains largely unchanged. From your laptop to phone and tablet touch screens used on Earth and even by astronauts in space – the next time you use your QWERTY keyboard, think of the development it's gone through to this day. Who knows where it may go next?



La quintessence de la révolution moderne

La machine à écrire classique était un instrument précieux pour les entreprises du monde entier, tout comme elle l'a été pour Ole Kirk Kristiansen (montré ici) et son travail au sein du Groupe LEGO. Des auteurs emblématiques ont créé certaines des œuvres littéraires modernes les plus appréciées au monde sur leur machine à écrire. En tapant sur les touches, des journalistes d'enquête ont mis leur réputation en jeu pour dévoiler la vérité, et des amis et des proches ont exprimé toute leur affection. C'est un emblème de la révolution moderne.

Inventées en 1874, les premières machines à écrire commerciales ont mis une décennie à se tailler une place dans la culture dominante. Présentes dans la plupart des bureaux et des foyers pendant près de cent ans, les machines à écrire ont remplacé la rédaction de documents manuscrits et établi de nouvelles normes pour la correspondance. Certains amateurs adultes se souviennent peut-être avoir suivi des cours de dactylographie à l'école, un nombre élevé de mots tapés par minute étant une compétence convoitée à apposer sur son CV. L'odeur des pièces métalliques internes huilées, le sentiment gratifiant d'avoir tapé un document parfait sans faute de frappe, ou la sensation de l'encre sur vos mains le moment venu de changer le ruban.

Les plus jeunes amateurs ont grandi avec des ordinateurs et des claviers électroniques au bout des doigts. Bien que la fonctionnalité s'est considérablement améliorée, la disposition du clavier a très peu changé. Elle est la même que ce soit sur un ordinateur ou sur l'écran tactile d'un téléphone ou d'une tablette, que l'utilisateur soit sur notre planète ou qu'il s'agisse d'un astronaute dans l'espace. La prochaine fois que vous utiliserez un clavier QWERTY, pensez aux changements qu'il a connus au fil du temps. Qui sait ce qui l'attend ?

Un építome de la revolución moderna

La clásica máquina de escribir era un instrumento de valor incalculable para las empresas de todo el mundo, como lo fue también para Ole Kirk Kristiansen (en la imagen) y el trabajo que realizó durante toda su vida en The LEGO Group. Famosos autores crearon algunas de las obras literarias más importantes del mundo con las suyas. También los reporteros de investigación las usaban, arriesgando su reputación en la lucha por desentrañar la verdad, y amigos y parientes volcaban su corazón sobre las teclas. Es sin duda un ícono de la revolución moderna.

Inventadas en 1874, las primeras máquinas de escribir comerciales tardaron una década en hacerse un lugar en la cultura dominante. Por casi cien años, fue un elemento imprescindible en la mayoría de las oficinas y hogares, donde vino a sustituir las notas escritas a mano y a establecer nuevas pautas para la correspondencia. Algunos fans adultos recordarán haber tomado clases de mecanografía en la escuela, cuando la cantidad de palabras que una persona podía teclear por minuto era una habilidad digna de mencionarse en su currículum, y cuanto mayor, más apreciada. Sin esperarlo, el olor del aceite en las partes metálicas internas, la gratificante sensación de un documento perfecto, libre de errores tipográficos, o la mancha de tinta en las manos al cambiar la cinta se convertirían en marcas indelebles en la memoria.

Al haber crecido entre computadoras, escribir en teclados electrónicos se convirtió en una habilidad natural para los fans más jóvenes. Aunque su funcionalidad ha experimentado importantes mejoras, la distribución del teclado en sí sigue siendo prácticamente la misma, ya sea en tu computadora portátil o en las pantallas táctiles de los teléfonos y tabletas que se utilizan en la Tierra, e incluso en los que usan los astronautas en el espacio. La próxima vez que utilices un teclado QWERTY, piensa en cómo ha evolucionado hasta el día de hoy. ¿Quién sabe hasta dónde podrá llegar?



Ole Kirk Kristiansen



Meet the man behind the keys

Steve Guinness from Chester, UK is a life-long LEGO® fan and schoolteacher of Design and Technology, who has turned his passion for creativity and LEGO bricks into a dream job.

"I now teach part time and also have my own business making bespoke LEGO models and running LEGO workshops for local schools, libraries and museums. I have been interested in LEGO building since I was a young child. It's a fantastic system and I'm passionate about showing other adults it's not just a kids' toy, it's something people of all ages can enjoy."

A great type of challenge

Steve loves classic, manual typewriters and wanted to see how far he could take a LEGO version of one.

"I bought a vintage typewriter for research and started playing with bricks and mechanisms. The first version took about two weeks to complete and then I spent weeks revising and improving it in seven different versions."

"The keyboard layout was a challenge. I tested a number of different techniques and when I reduced the size of the typewriter, it all came together. I love the mechanical design and the hand crank with its realistic movement and signature clicking sound of a real typewriter. Thanks to everyone who helped make this model come to life. I hope it will bring nostalgia to adult fans like me and wonder and curiosity to younger fans who might never have seen a real typewriter!"



Rencontrez l'homme derrière les touches

Amateur de LEGO® depuis toujours et enseignant de conception et de technologie, Steve Guinness, de Chester au Royaume-Uni, a transformé sa passion pour la créativité et les briques LEGO en un emploi de rêve.

« J'enseigne maintenant à temps partiel et je gère aussi ma propre entreprise de modèles LEGO sur mesure, qui organise des ateliers LEGO pour les écoles, les bibliothèques et les musées locaux. Je m'intéresse à la construction LEGO depuis que je suis tout petit. C'est un système fantastique et j'adore montrer aux autres adultes que ce n'est pas seulement un jouet pour enfants; c'est quelque chose que les gens de tous âges peuvent apprécier. »

Un défi unique

Passionné de machines à écrire manuelles, Steve a voulu tester les limites d'une version LEGO d'une de ces machines.

« J'ai acheté une machine à écrire d'époque comme référence et j'ai commencé à jouer avec les briques et les mécanismes. J'ai mis environ deux semaines à compléter le premier modèle, puis j'ai passé quelques semaines à le retravailler pour en faire sept versions différentes. »

« La disposition du clavier représentait un défi de taille. J'ai testé plusieurs techniques différentes et lorsque j'ai réduit la taille de la machine à écrire, tout s'est concrétisé. J'adore la conception mécanique, la manivelle au mouvement réaliste et le cliquetis caractéristique d'une vraie machine à écrire. Merci à tous ceux qui ont contribué à faire de ce modèle une réalité. J'espère qu'il saura susciter nostalgie chez les amateurs adultes comme moi, et émerveillement et curiosité chez les plus jeunes amateurs qui n'ont jamais vu une vraie machine à écrire ! »

Conoce al hombre detrás de las teclas

Steve Guinness, de Chester (Reino Unido), es un fan de LEGO® de toda la vida y docente de Diseño y Tecnología que ha convertido su pasión por la creatividad y los bricks LEGO en el trabajo de sus sueños.

"Ahora trabajo medio tiempo dando clases y, además, tengo mi propio negocio haciendo modelos LEGO a la medida y llevando a cabo talleres de LEGO para escuelas, bibliotecas y museos locales. Mi interés en la construcción con bricks LEGO se remonta a mi niñez. Es un sistema fantástico, y me apasiona mostrar a otros adultos que no se trata solo de un juguete para niños, sino que es algo que personas de todas las edades pueden disfrutar".

Un desafío genial

A Steve le encantan las clásicas máquinas de escribir manuales y quería ver hasta dónde podía llevar la versión LEGO de una de ellas.

"Compré una máquina de escribir antigua para investigar y empecé a jugar con bricks y mecanismos. Tardé unas dos semanas en completar la primera versión, y luego pasé semanas revisándola y mejorándola, creando siete versiones diferentes en el proceso".

"El diseño del teclado fue un desafío. Probé con varias técnicas distintas, y cuando reduje el tamaño de la máquina de escribir, todo comenzó a funcionar. Me encantan el diseño mecánico y el movimiento realista de la palanca, así como el característico sonido de golpeteo de una máquina de escribir de verdad. Gracias a todos los que contribuyeron a que este modelo cobrara vida. ¡Espero que evoque nostalgia a los fans adultos como yo y maraville e inspire curiosidad a los fans más jóvenes, que tal vez nunca hayan visto una máquina de escribir real!".



The LEGO® Ideas newshounds

LEGO® Ideas designers James May, Wes Talbott and Martin Fink immediately donned their retro thinking caps when Steve's model landed on their desks. The opportunity to investigate and experiment with classic vintage technology and new LEGO building techniques was simply an irresistible combination.

"I loved how the original model looked so realistic. We wanted to build on it by developing a rotating platen, which now means real paper can actually feed through it! I hope fans will love the abundance of features and functions like this we packed into the model."

– James May, LEGO Model Designer

"Steve's attention to detail is just remarkable. We included aesthetics into the model that any fan of typewriters would expect to see, like the lever to change the ink color and manufacturer's label. The escapement where all the key arms connect with the metallic tiles, and how the textile ribbon fits behind it, is the main focal point for the model."

– Wes Talbott, LEGO Design Master

"We had fun experimenting with different graphic designs for the keys and the manufacturer's name on the back. We went through a series of different styles, shapes and forms before we landed on this 1950s-inspired look and feel. And, of course, with an iconic LEGO identity."

– Martin Fink, LEGO Graphic Designer

Les journalistes de LEGO® Ideas

Les concepteurs de LEGO® Ideas James May, Wes Talbott et Martin Fink ont immédiatement fait travailler leurs méninges lorsque le modèle de Steve a atterri sur leur bureau. La chance de pouvoir combiner la technologie d'époque classique avec les nouvelles techniques de construction LEGO était tout simplement irrésistible.

« J'ai adoré l'aspect réaliste du modèle original. Nous voulions aller plus loin en développant un cylindre tournant, pour permettre à de vraies feuilles de papier de passer à l'intérieur ! J'espère que les amateurs apprécieront les multiples caractéristiques et fonctionnalités dont le modèle regorge. »

– James May, concepteur de modèles LEGO

« L'attention que Steve a portée aux détails est tout simplement remarquable. Nous avons inclus dans le modèle des éléments esthétiques que tout amateur de machines à écrire s'attendrait à voir, comme le levier pour changer la couleur de l'encre et l'étiquette du fabricant. L'échappement, où toutes les barres des touches rejoignent les tuiles métalliques, et la façon dont le ruban textile s'insère derrière lui, sont le point central du modèle. »

– Wes Talbott, maître de conception LEGO

« Nous avons adoré tester différents graphismes pour les touches et le nom du fabricant à l'arrière. Nous avons essayé une pléthore de formes et de styles différents avant d'en arriver à cet aspect inspiré des années 1950. Avec une touche LEGO, bien entendu. »

– Martin Fink, graphiste LEGO

Los reporteros de LEGO® Ideas

Los diseñadores de LEGO® Ideas James May, Wes Talbott y Martin Fink inmediatamente se pusieron sus gorras de pensamiento retro cuando el modelo de Steve aterrizó en sus escritorios. La oportunidad de investigar y experimentar con tecnologías antiguas y novedosas técnicas de construcción con LEGO fue simplemente una combinación irresistible.

"Me encantó cómo el modelo original se veía tan realista. Quisimos mejorarlo aún más incorporándole un rodillo que pudiera girar, ¡por eso ahora puede usar papel de verdad! Espero que a los fans les guste la variedad de características y funciones como esta que incluimos en el modelo".

– James May, diseñador de modelos en LEGO

"La atención a los detalles de Steve es simplemente notable. Los elementos estéticos que integramos en el modelo son los que cualquier fan de las máquinas de escribir esperaría ver, como la palanca para cambiar el color de la tinta y la etiqueta del fabricante. El mecanismo de escape, donde todos los brazos de las teclas se conectan con las cubiertas metálicas, y la manera en que la cinta textil se coloca detrás de este son los principales puntos focales del modelo".

– Wes Talbott, maestro de diseño en LEGO

"Nos divertimos experimentando con diferentes diseños gráficos para las teclas y el nombre del fabricante en la parte posterior. Pasamos por una serie de diferentes estilos, siluetas y formas antes de decidimos por este aspecto inspirado en la década de 1950 que, por supuesto, irradia la inconfundible identidad de LEGO".

– Martin Fink, diseñador gráfico en LEGO



James May · Wes Talbott
Martin Fink



[LEGO.com/brickseparator](https://www.lego.com/brickseparator)

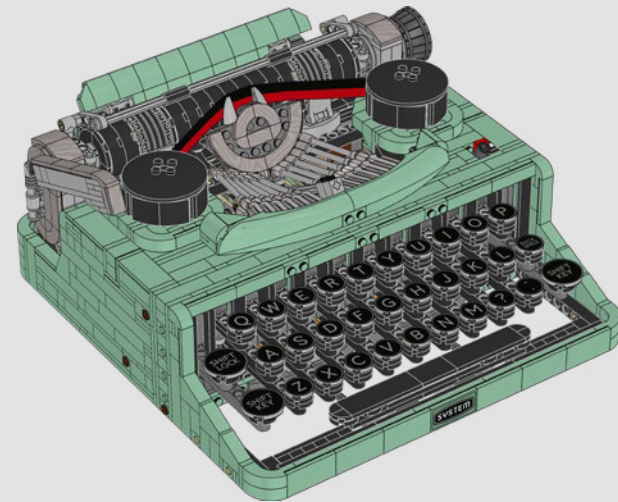
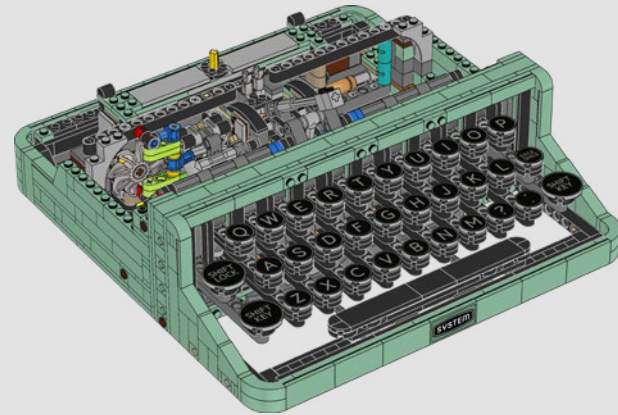
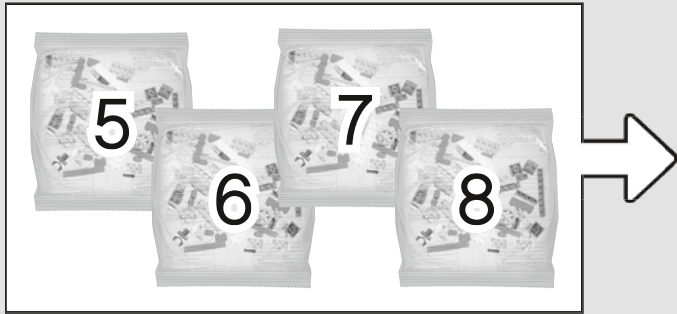
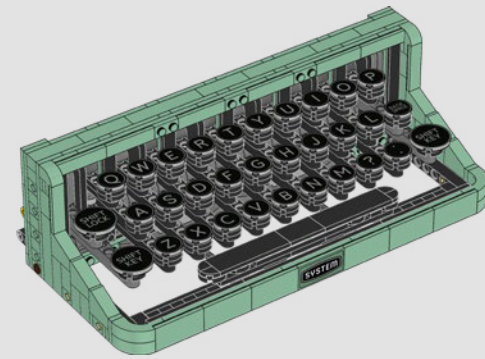
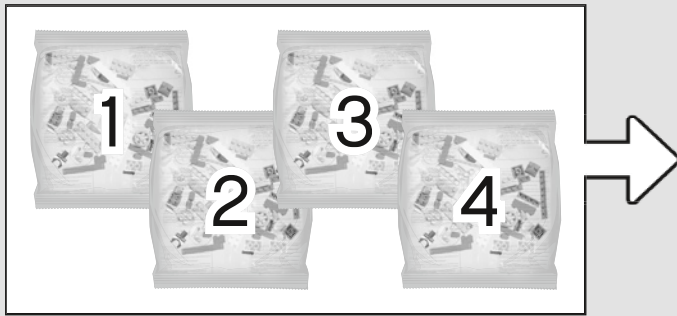

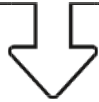

9x

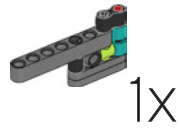

1x

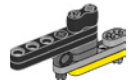

9x



1x

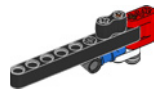

9x

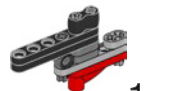

1x

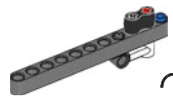

2x

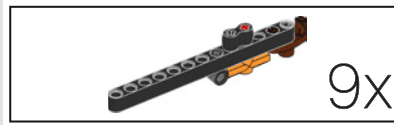

9x

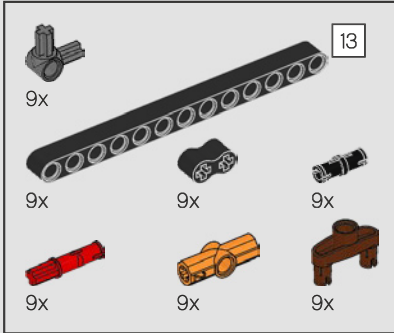

1

1

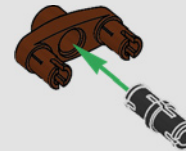

2

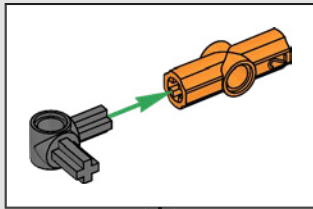
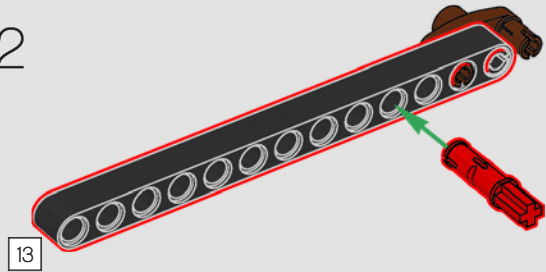

3

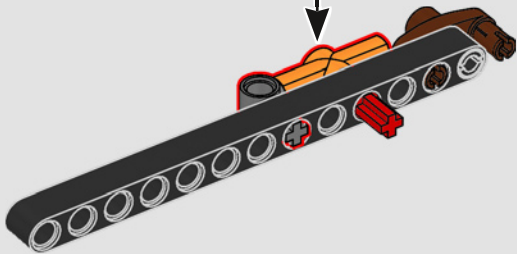

4

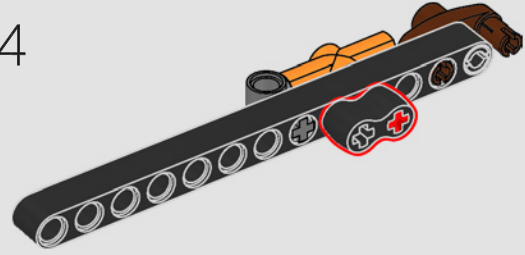

9x

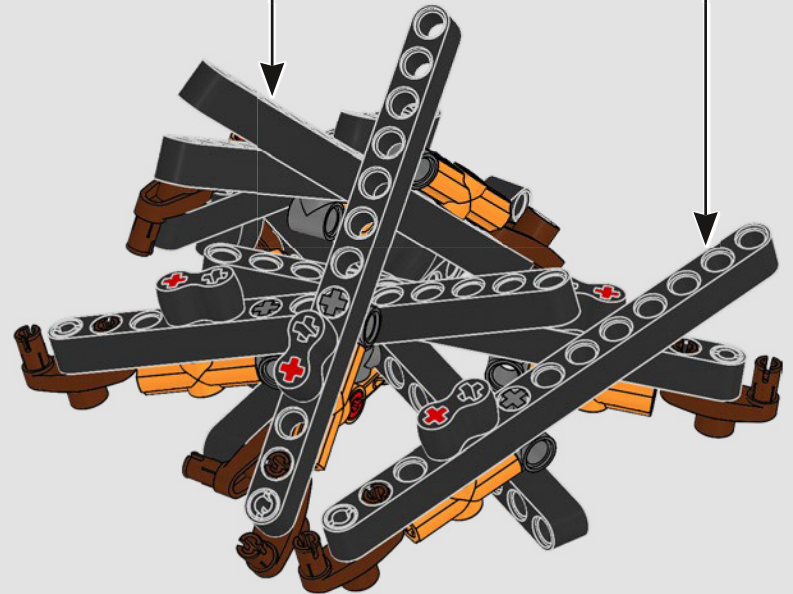

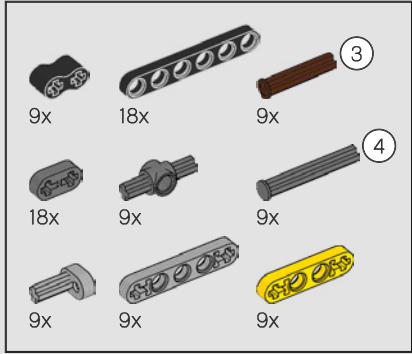
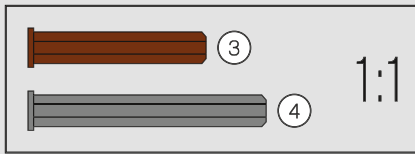
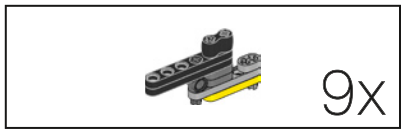

2

1

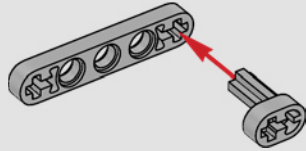

2

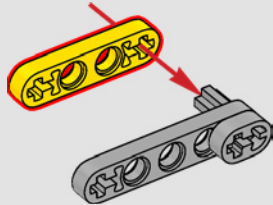

3

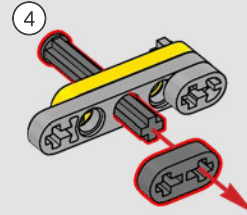

4

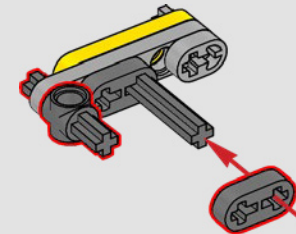

5

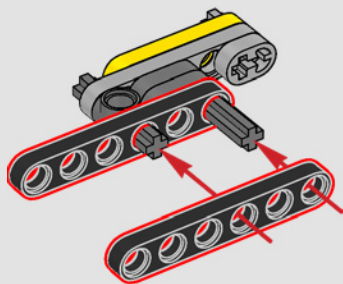

6

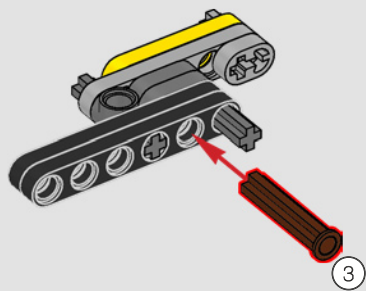

7

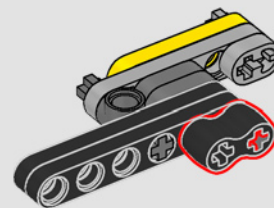

9x

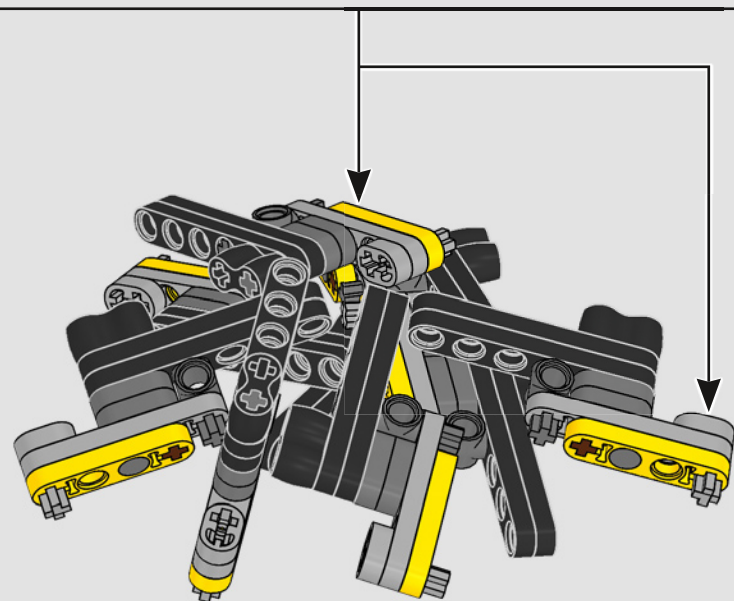

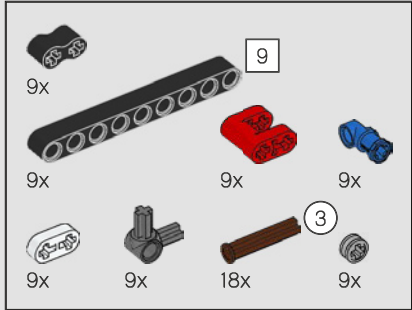
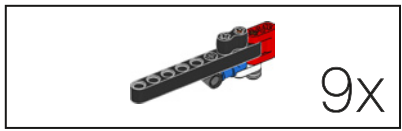

3

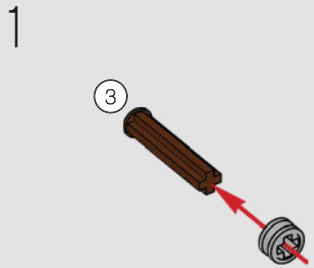

2



3

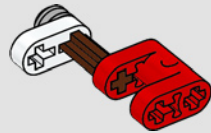

4

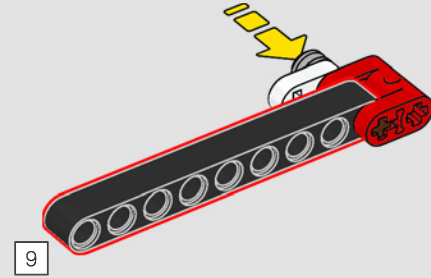

5

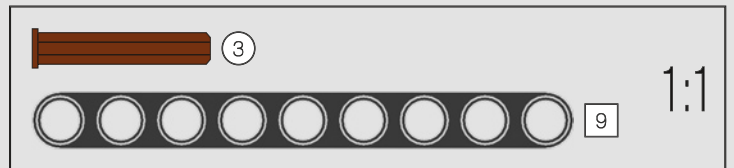
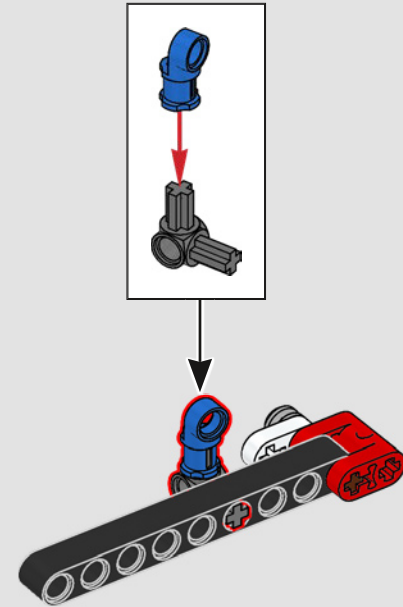

6

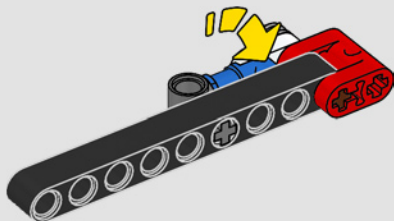

8

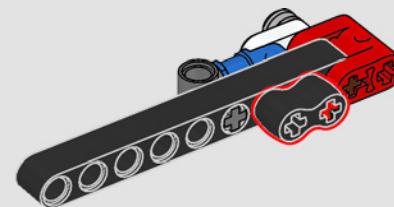

9x

7

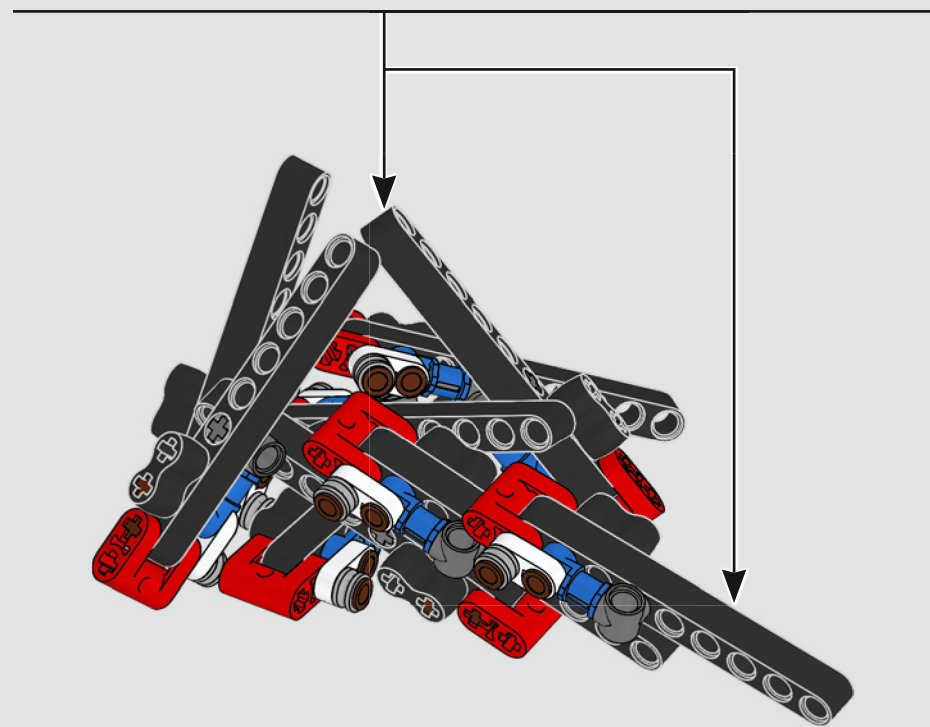
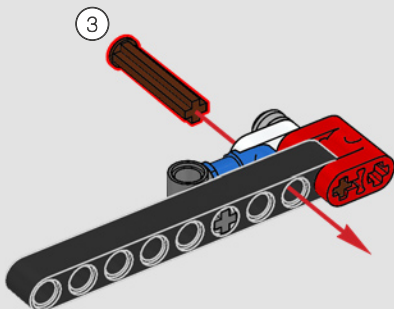

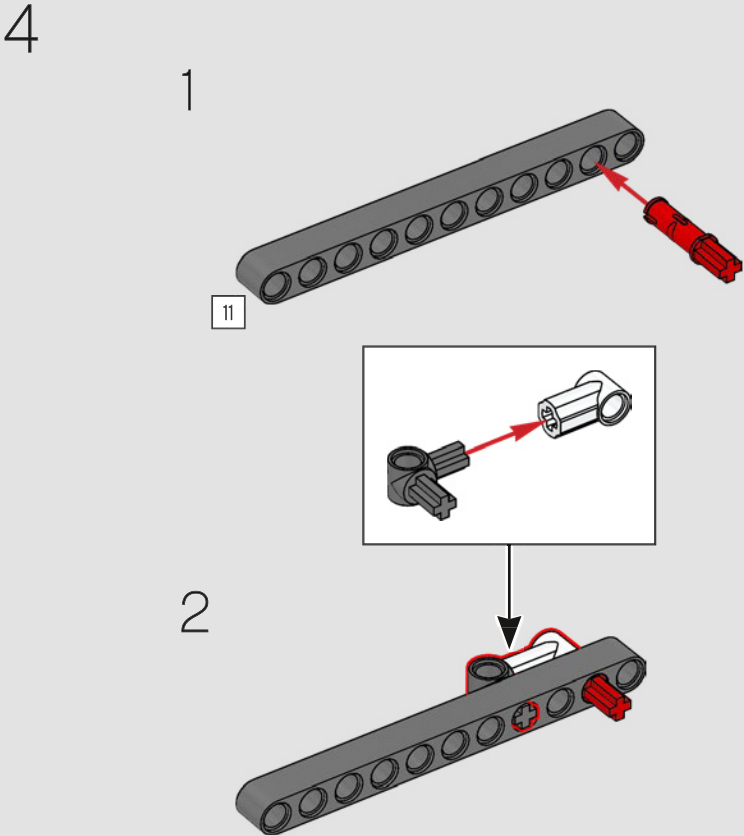
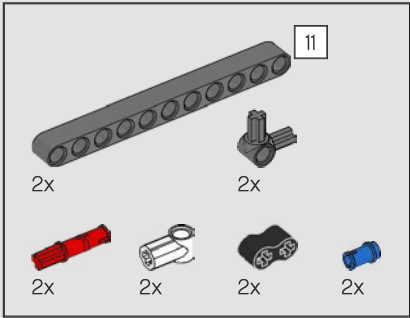
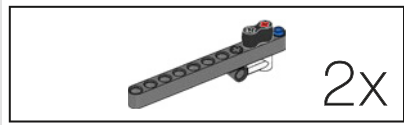

3

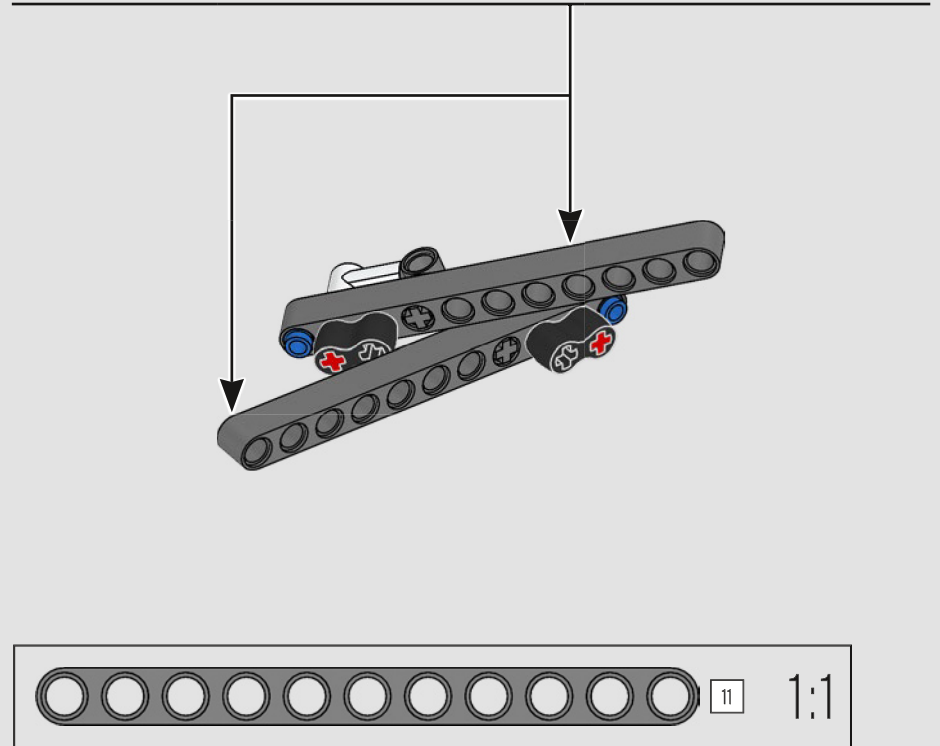
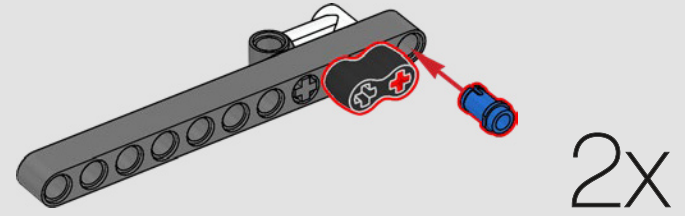

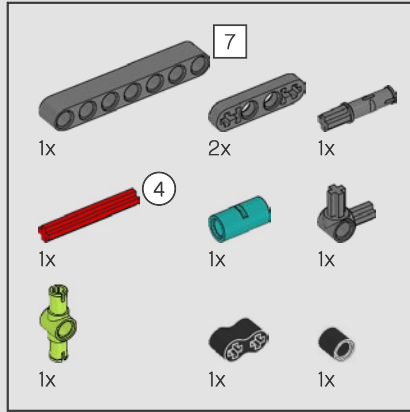
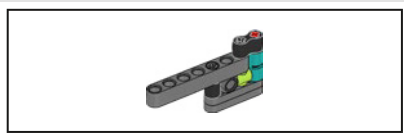

5

1

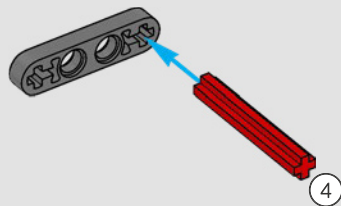

2

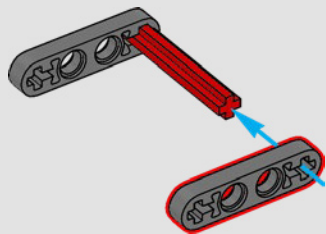

3

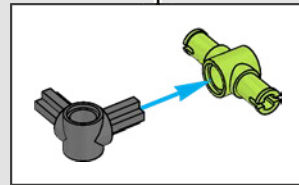
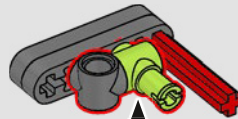

4

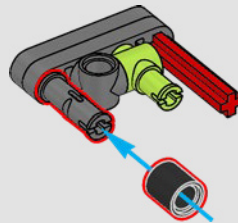

5

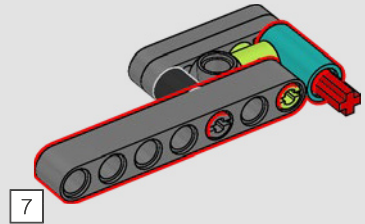

6

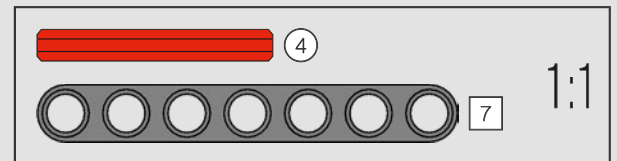
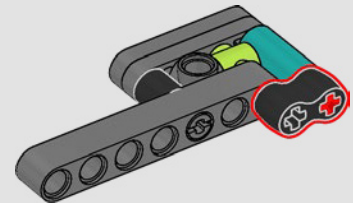

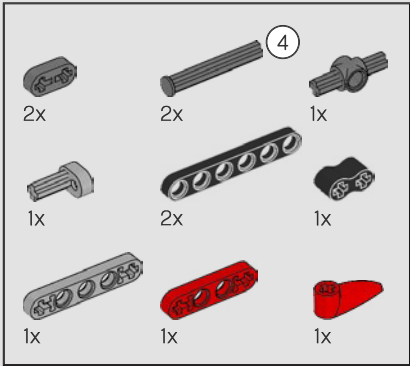
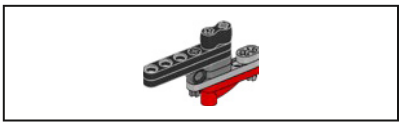

6

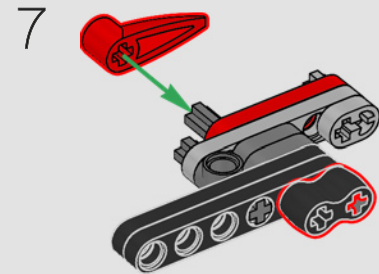
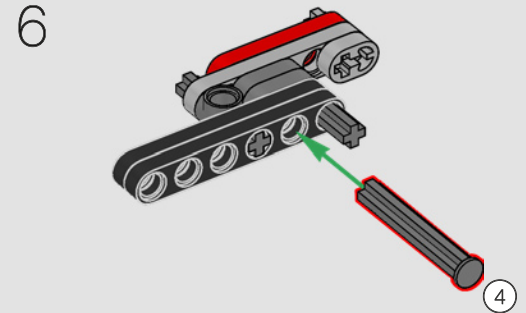
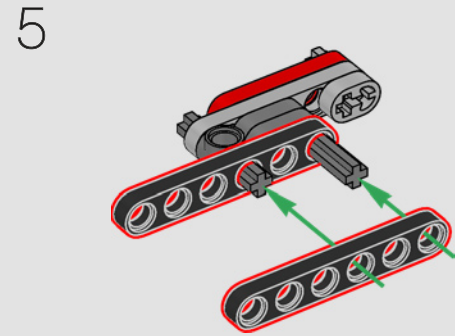
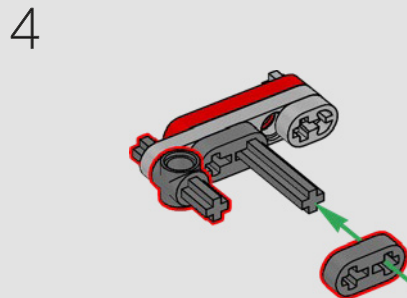
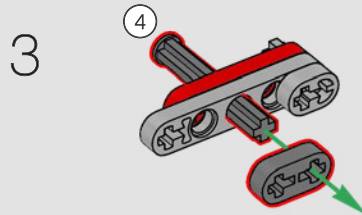
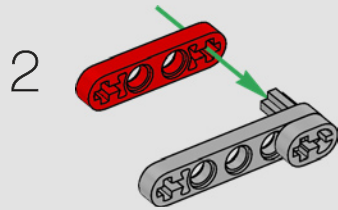
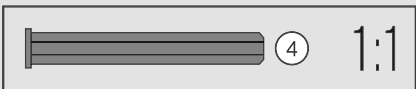
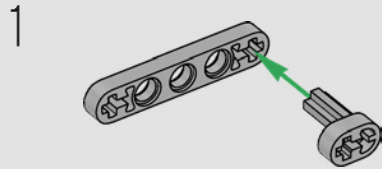

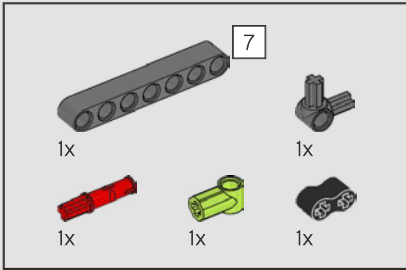
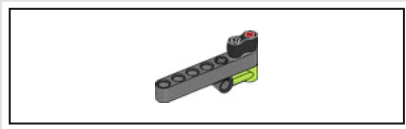

7

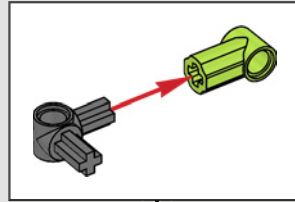

1

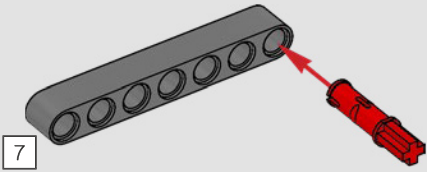

2

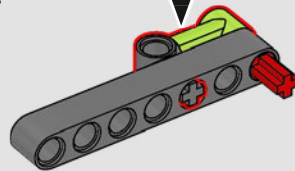

3

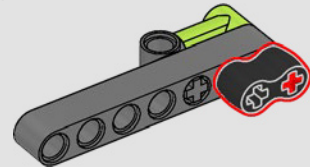

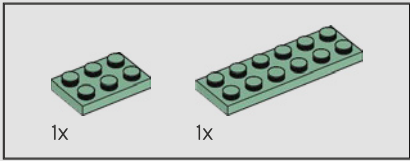
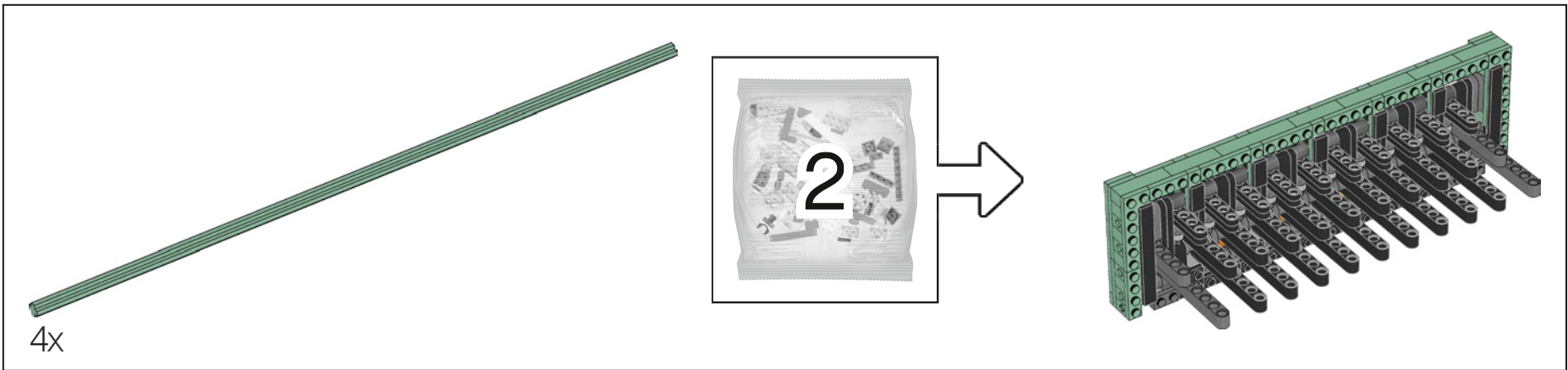

8

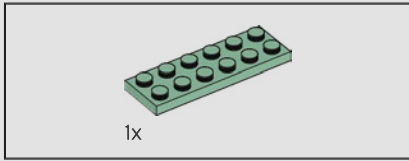
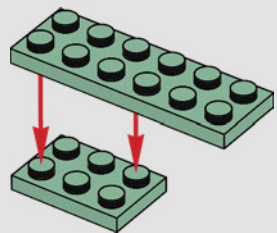

9

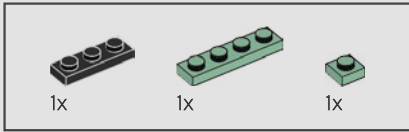
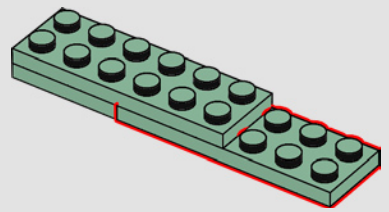

10

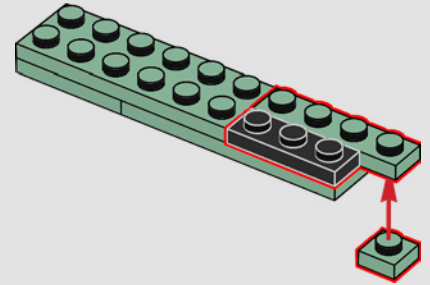

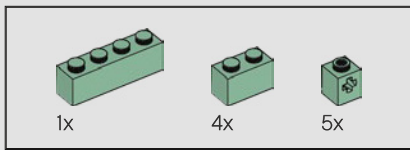

11

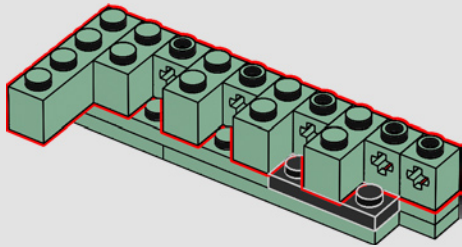

12

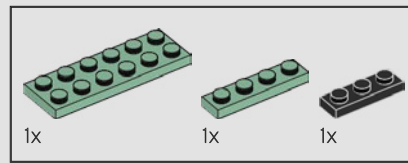
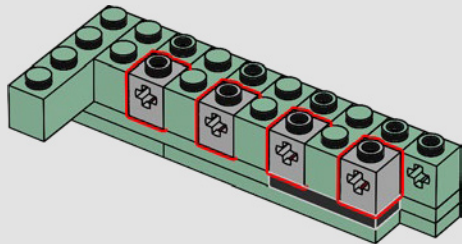

13

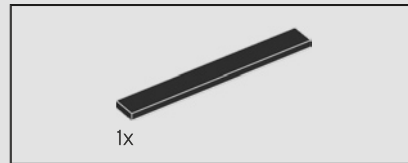
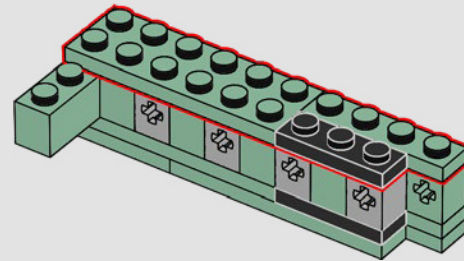

14

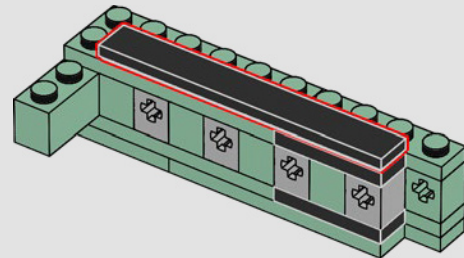

15

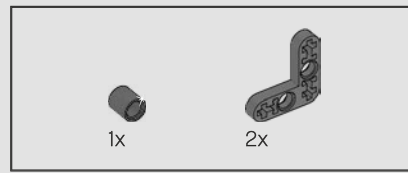

16

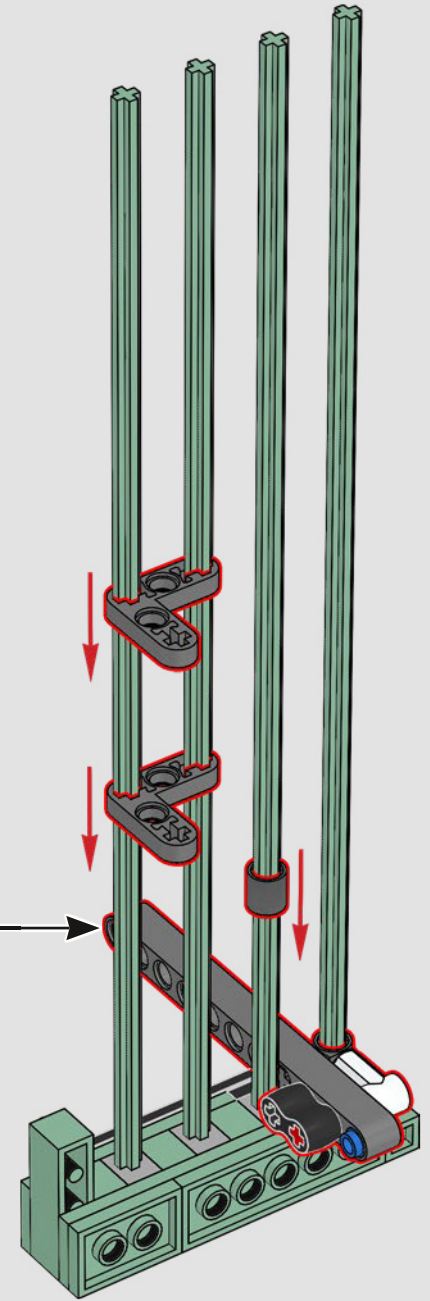
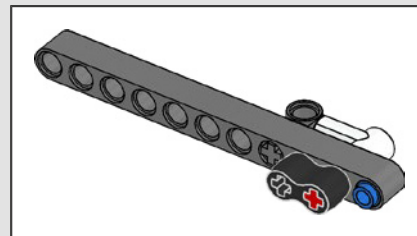

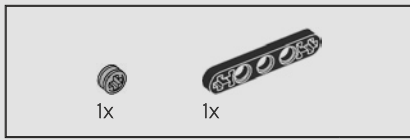

17

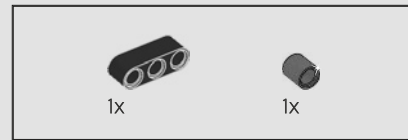
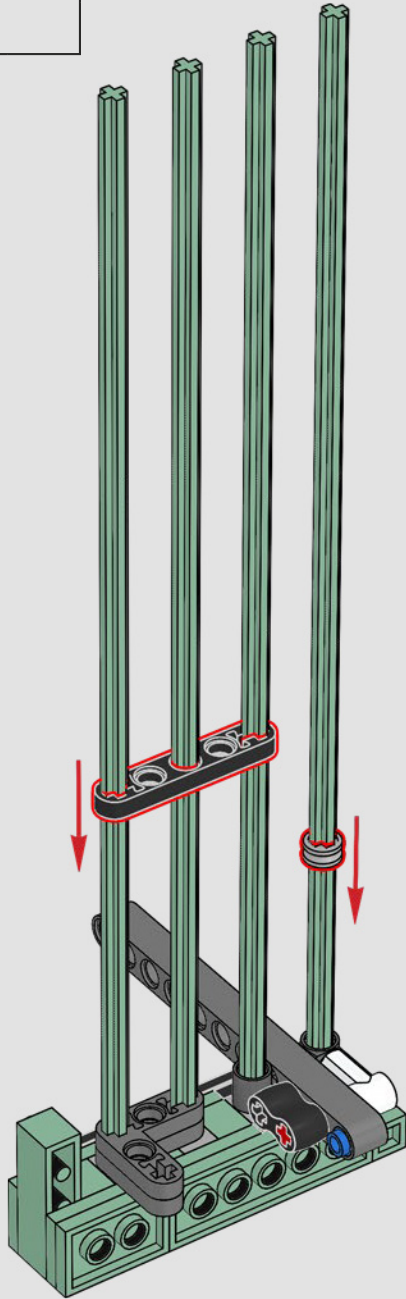

18

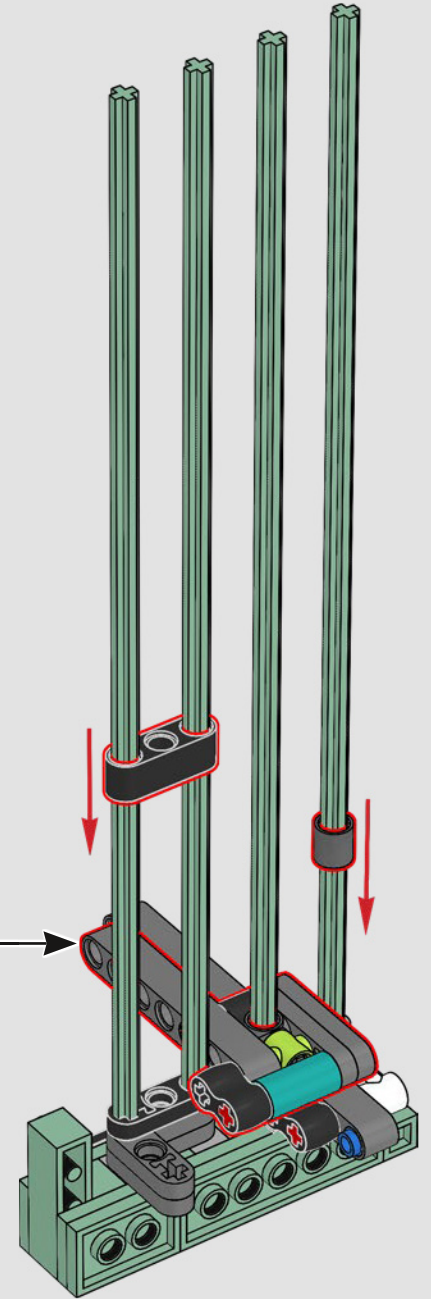
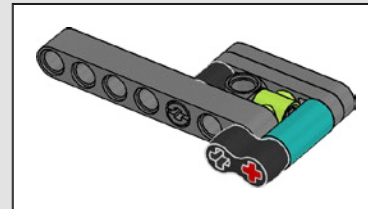

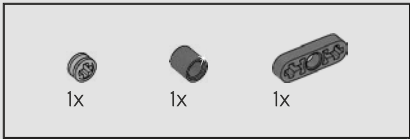

19

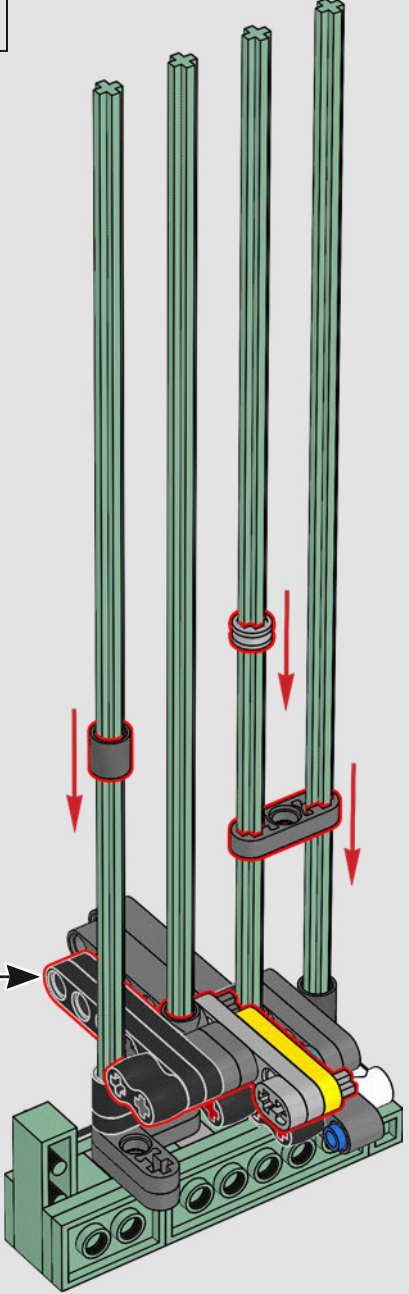
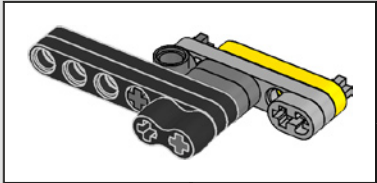

20

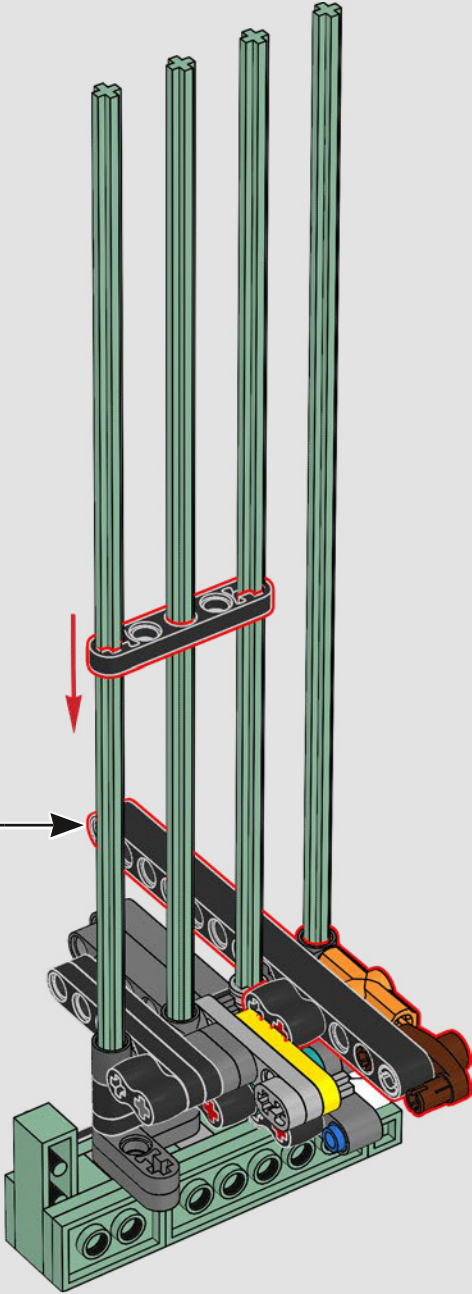
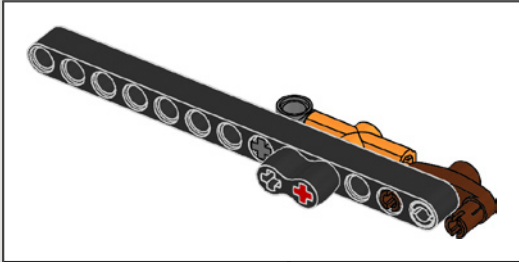

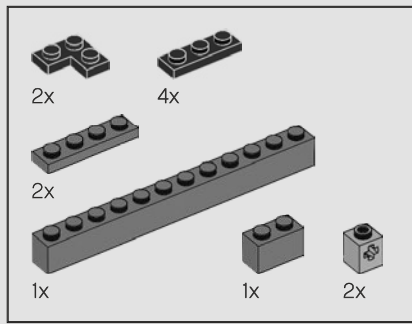

21

1

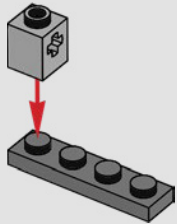

2

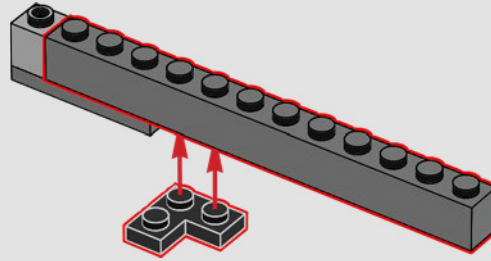

3

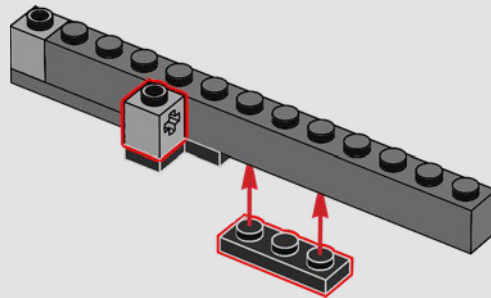

4

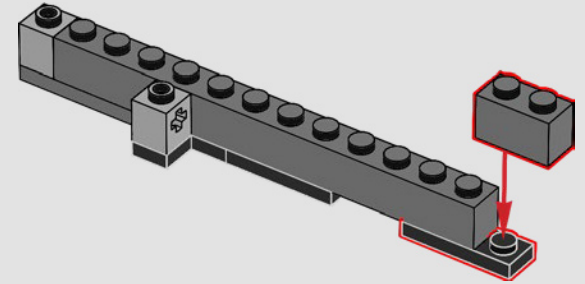

5

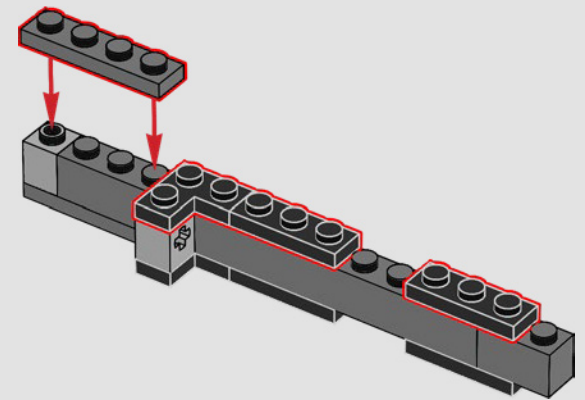

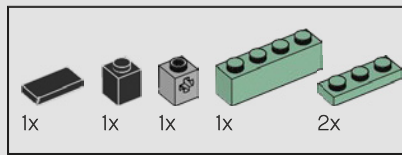
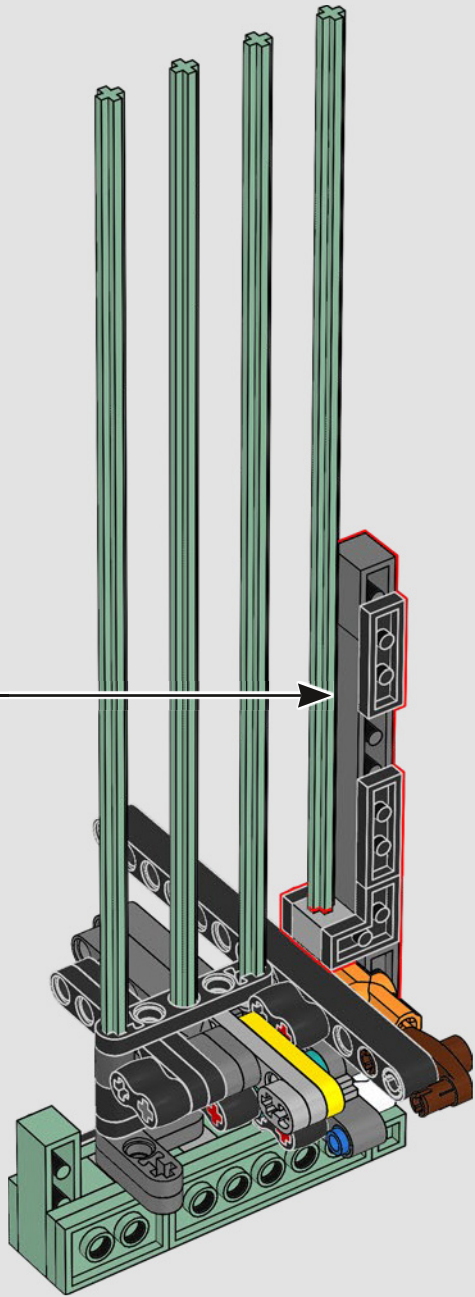

22

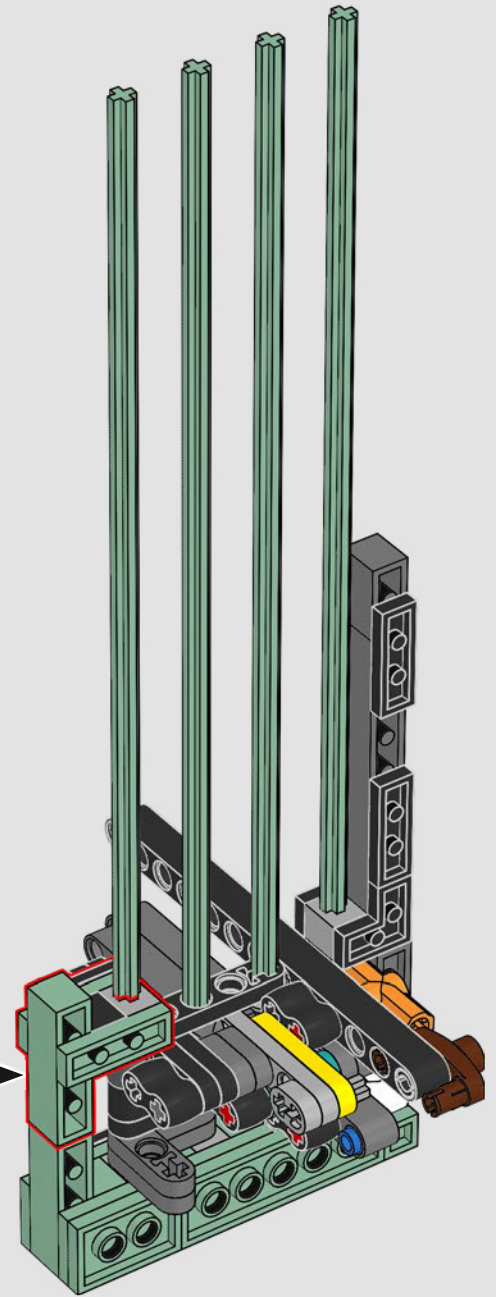
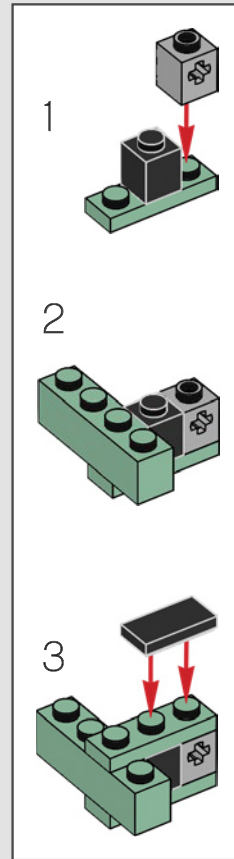

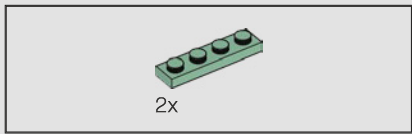

23

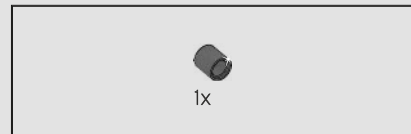
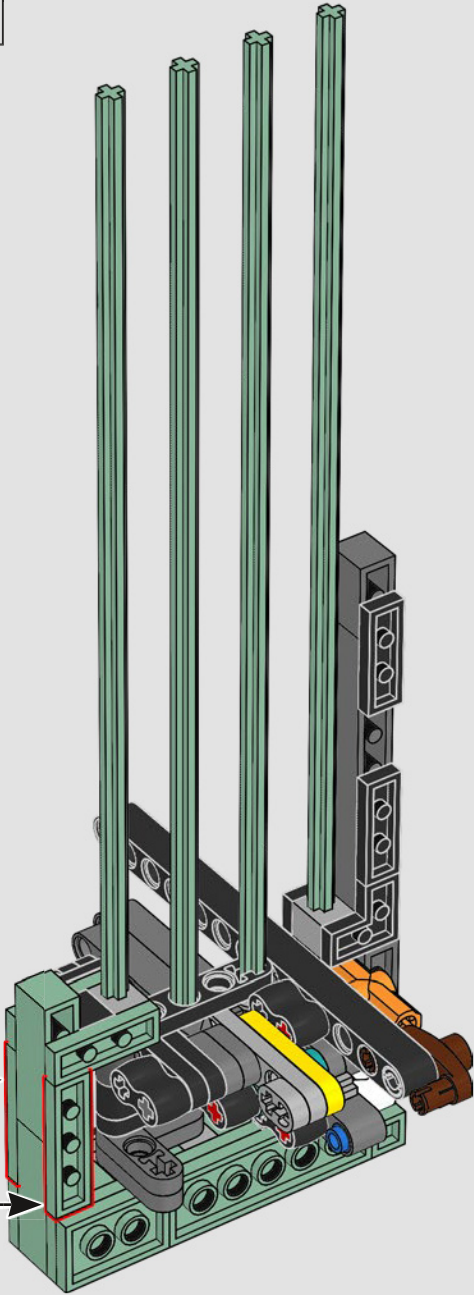
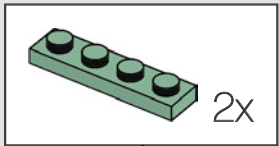

24

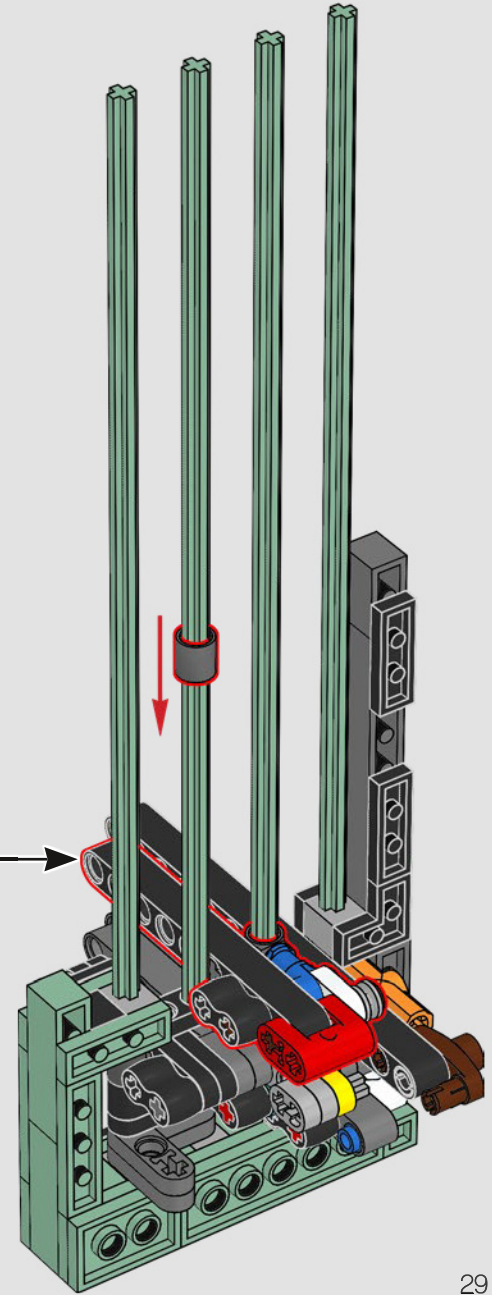
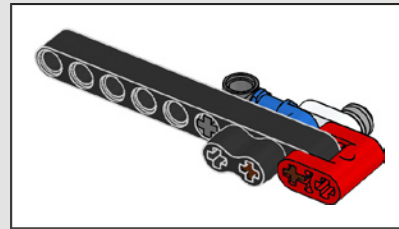

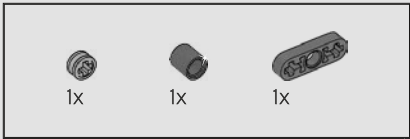

25

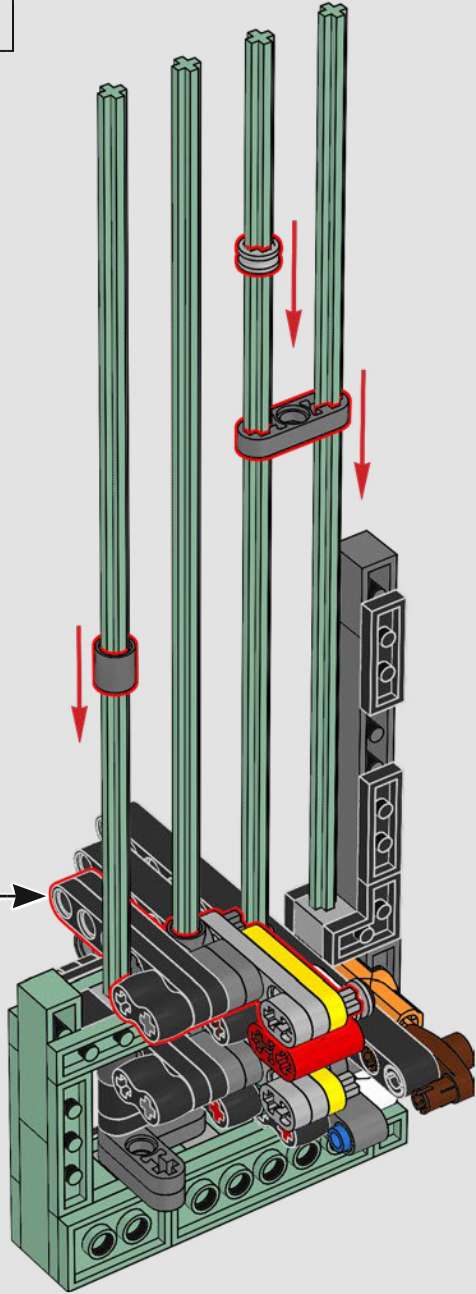
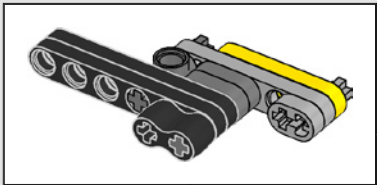

26

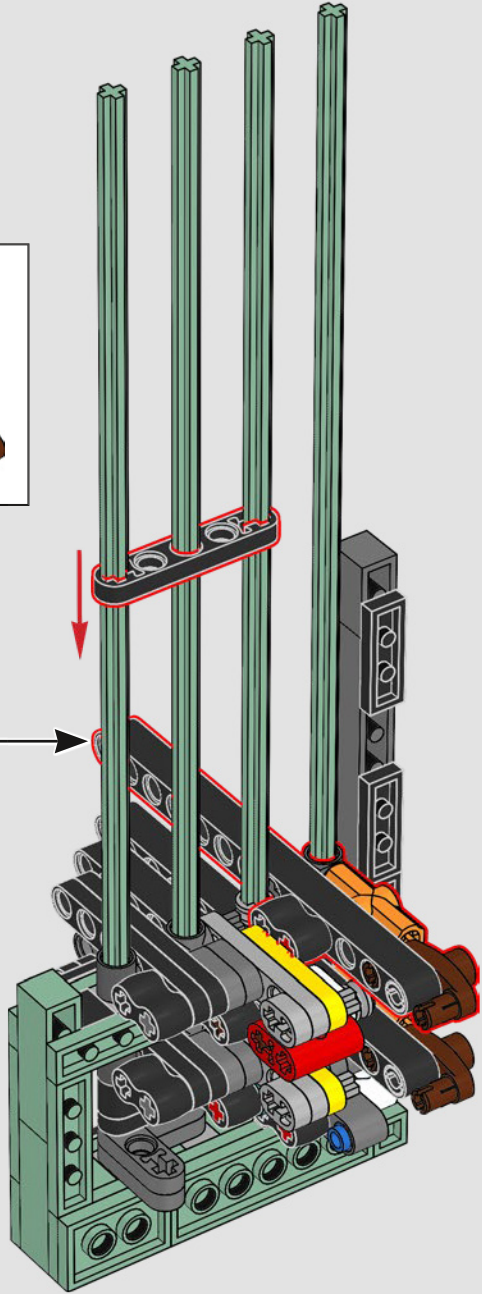
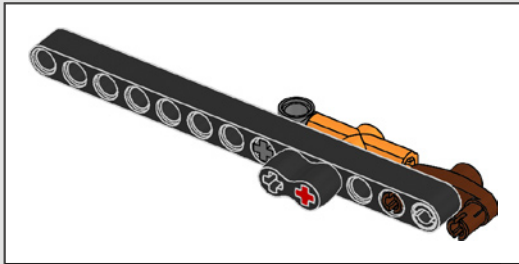

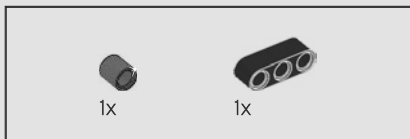

27

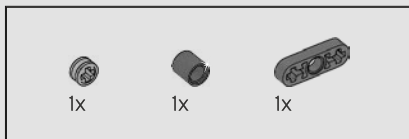
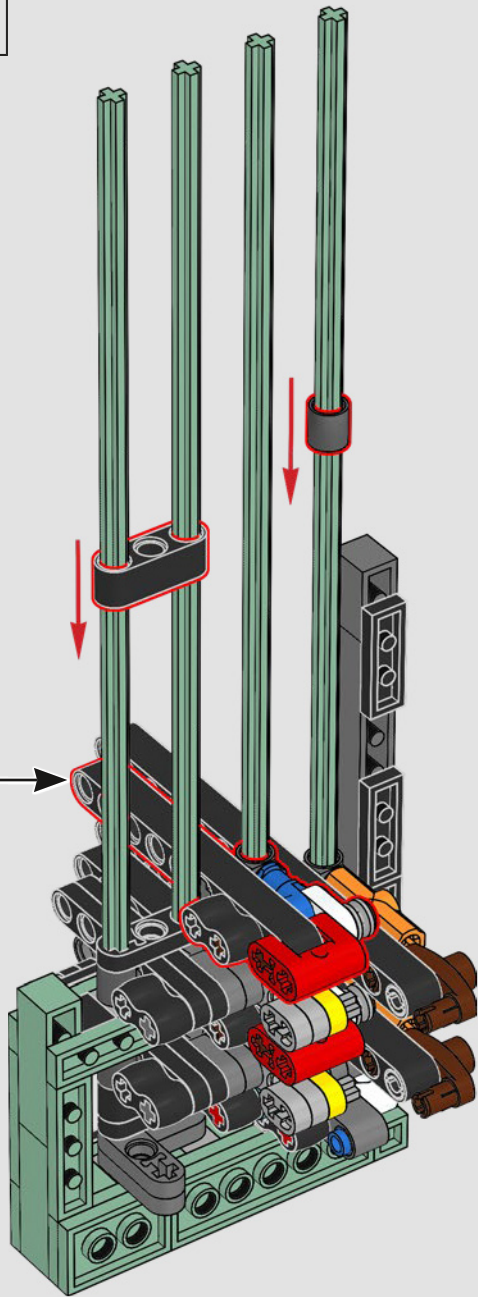
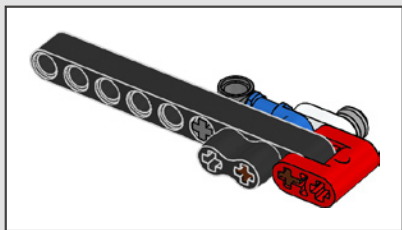

28

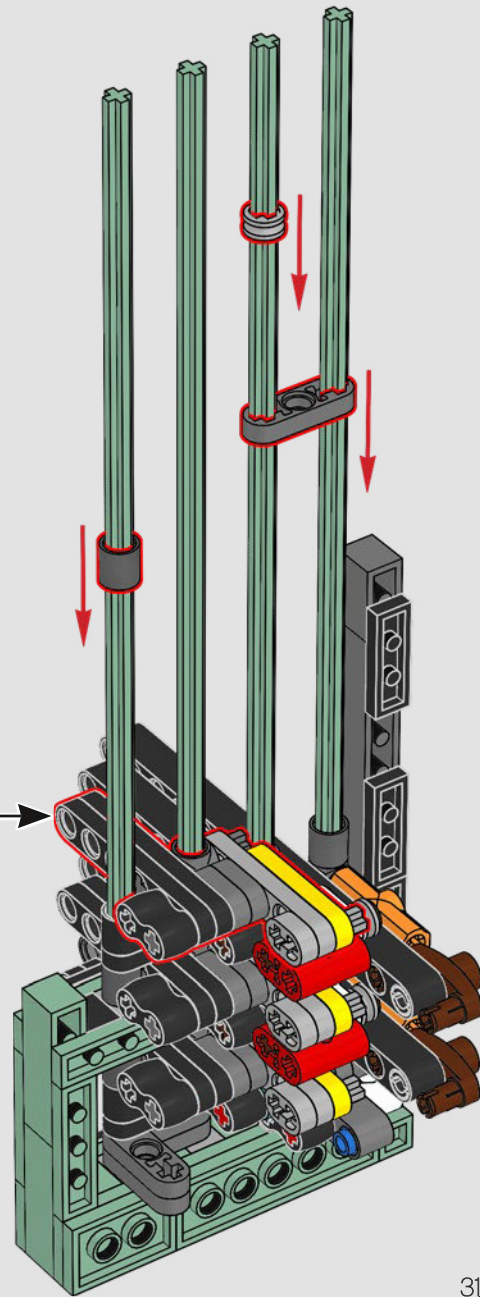
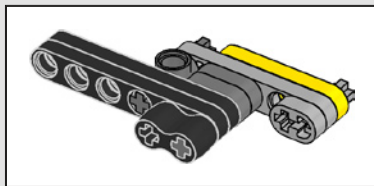



29

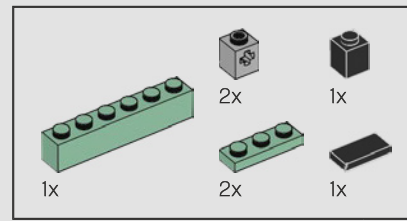
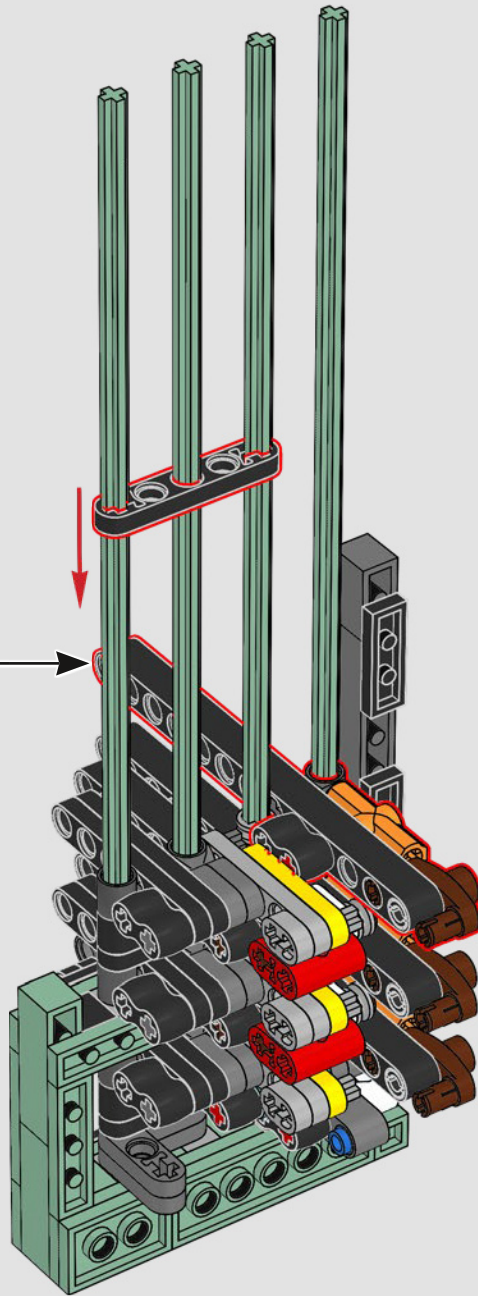
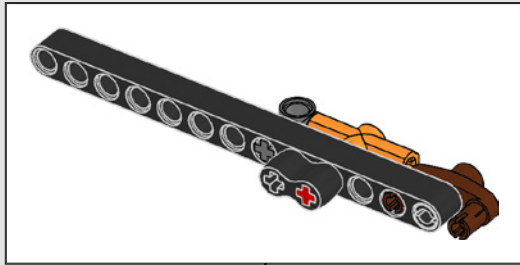

30

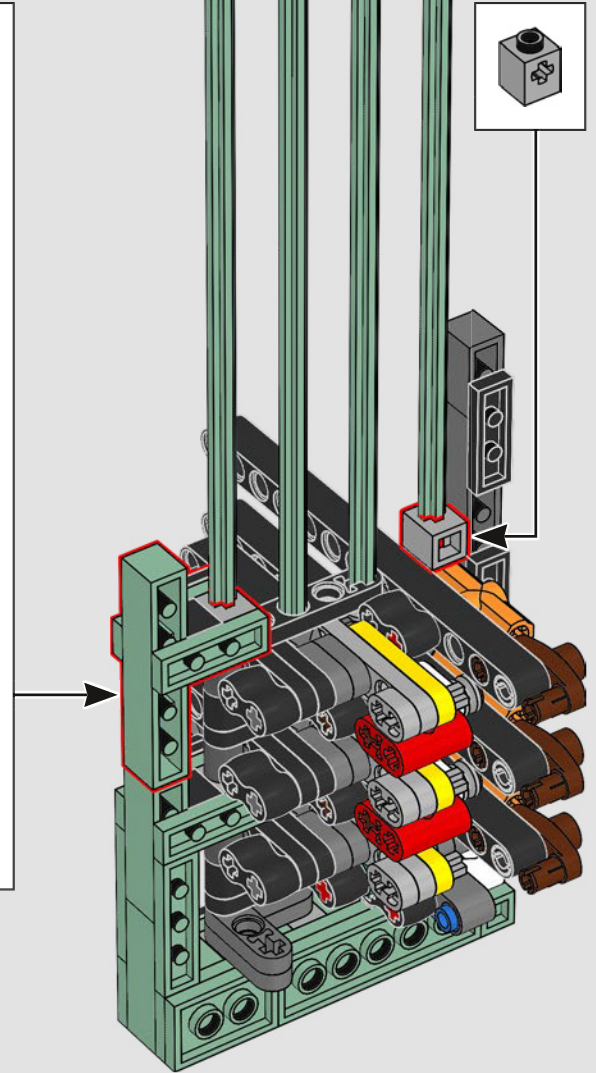
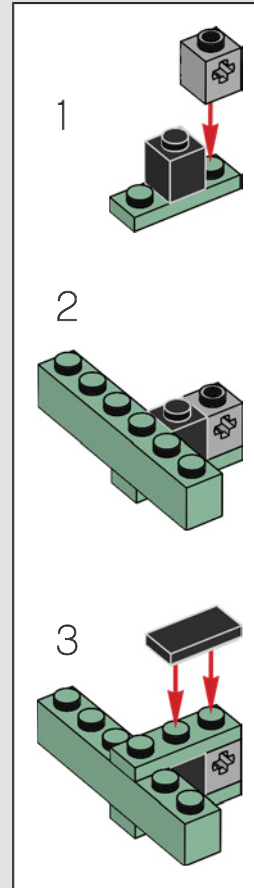



31

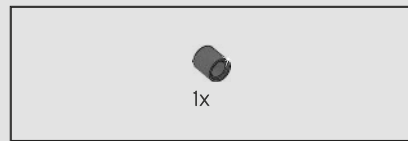
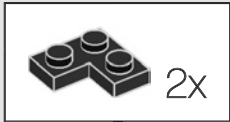
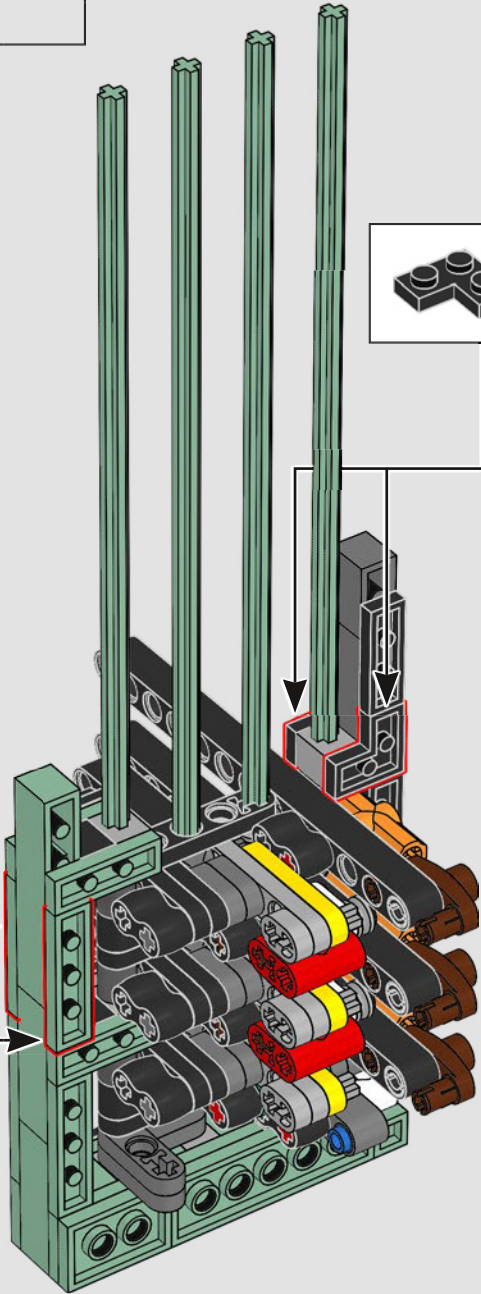
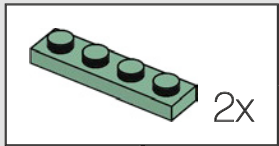

32

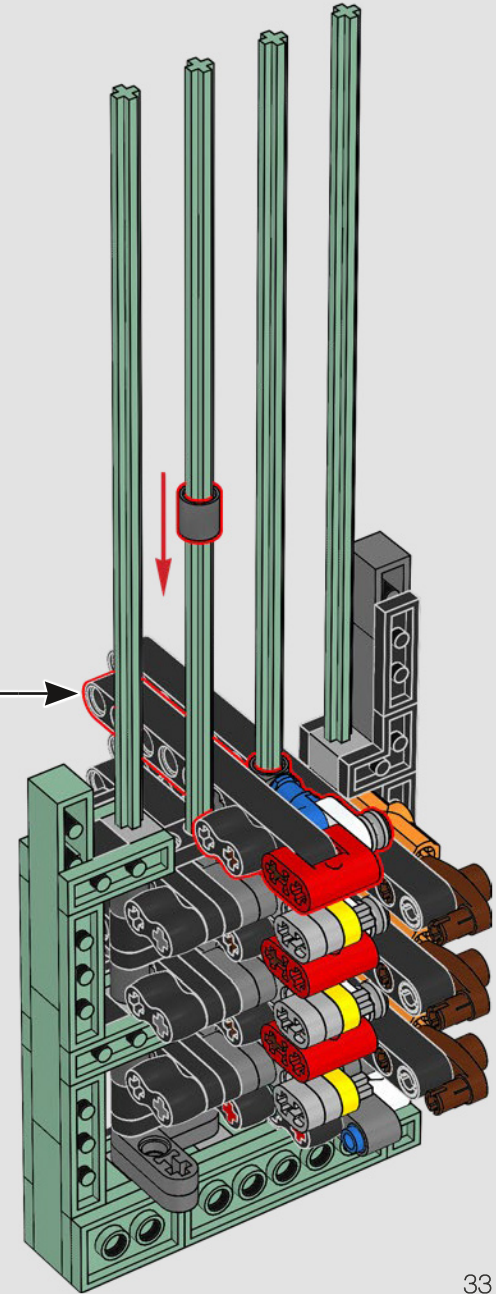
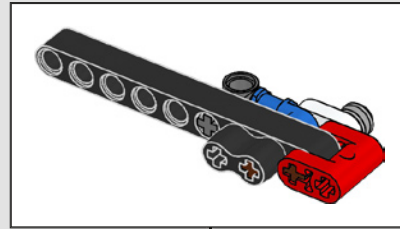

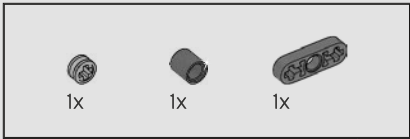

33

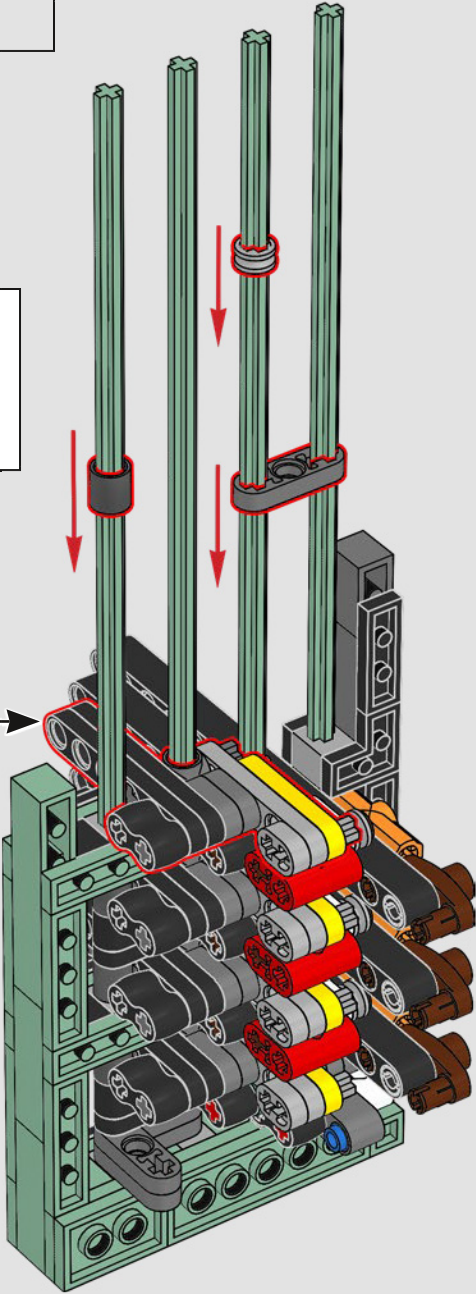
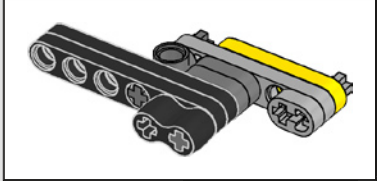

34

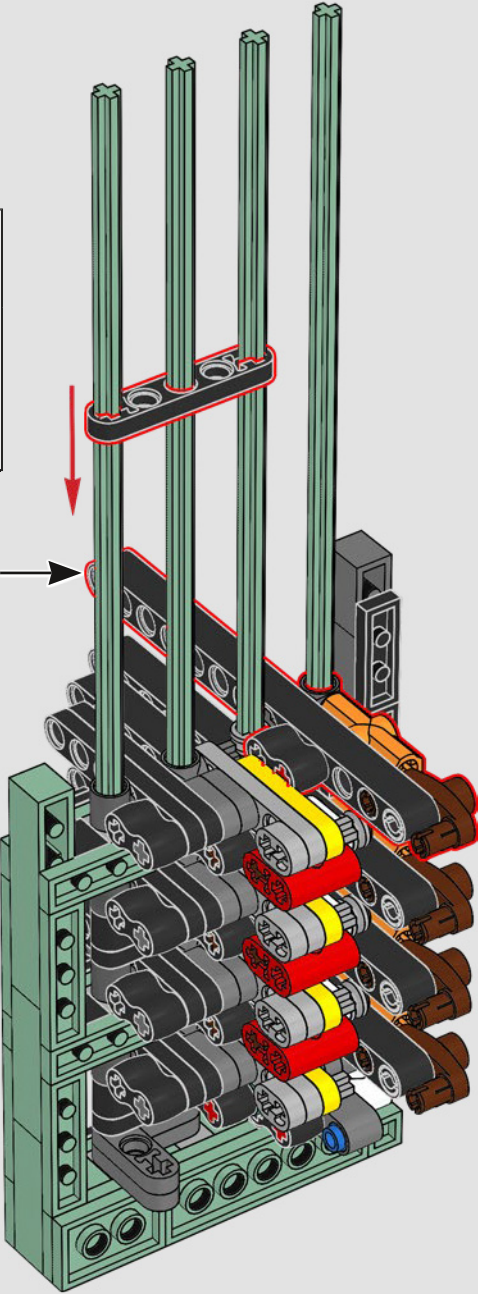
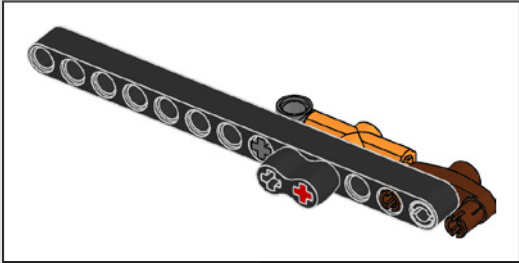

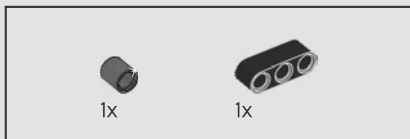

35

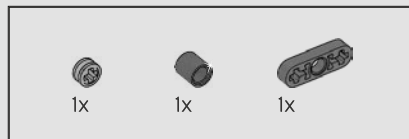
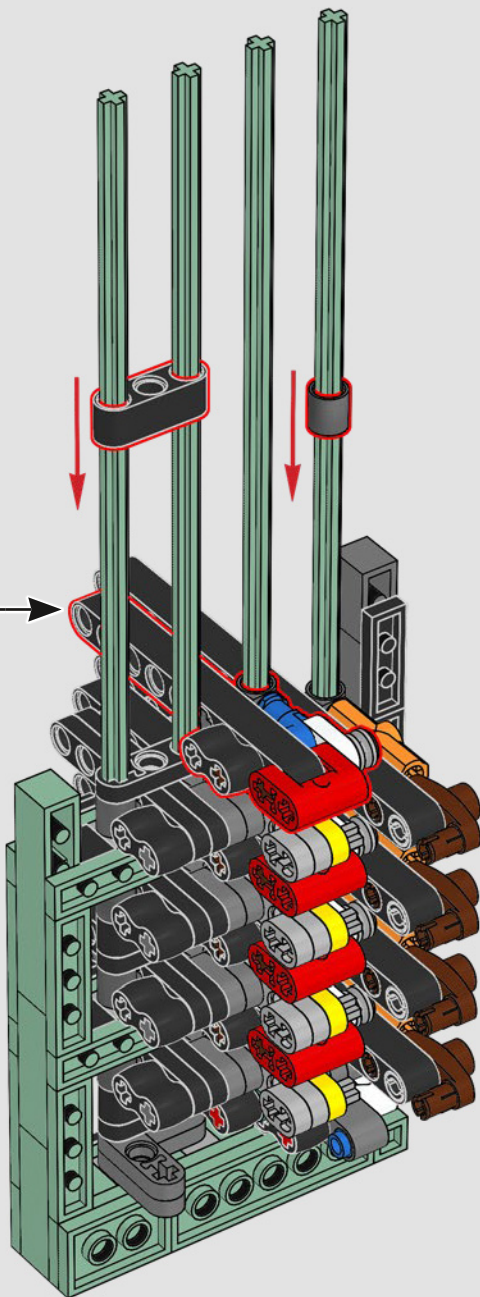
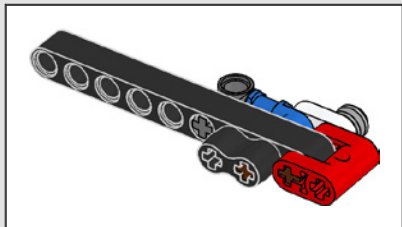

36

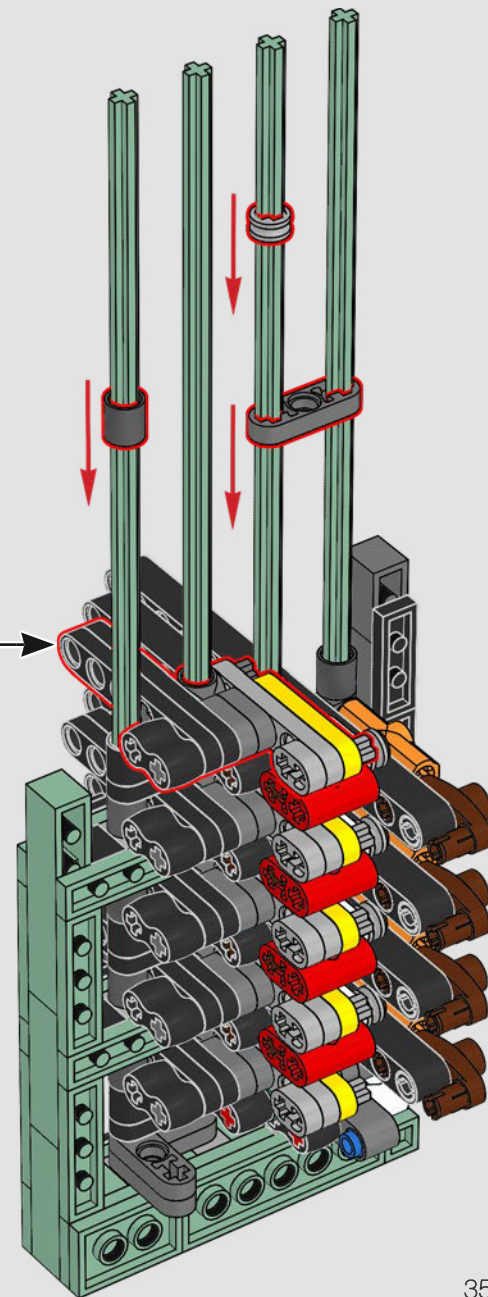
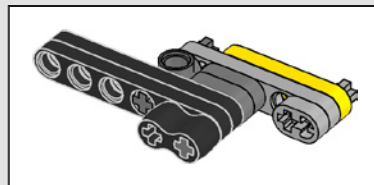

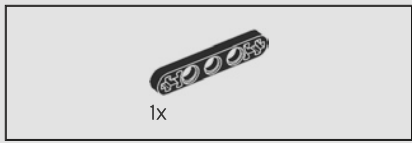

37

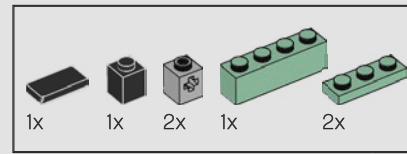
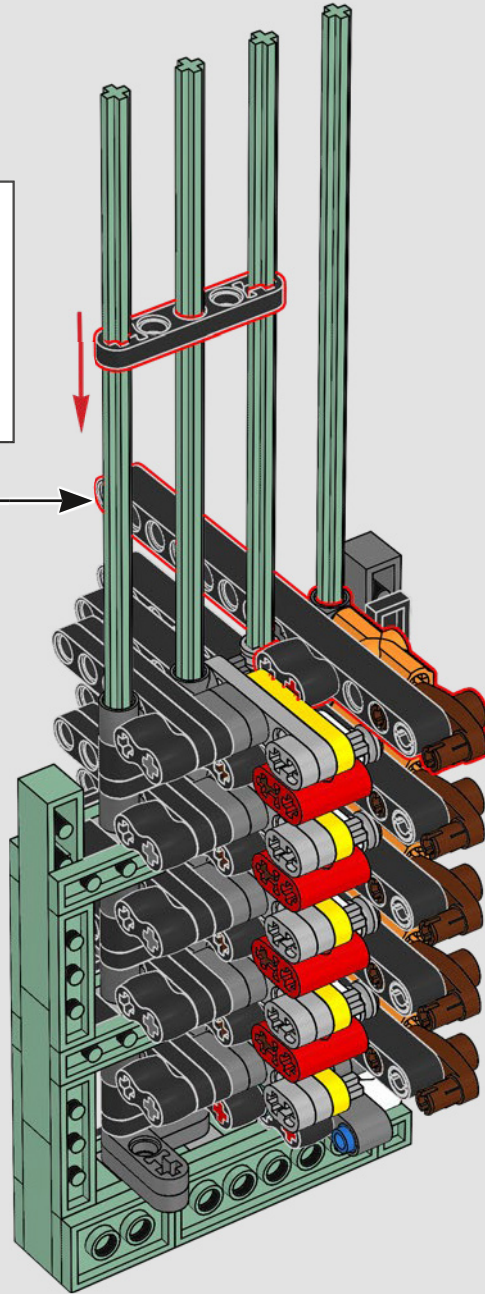
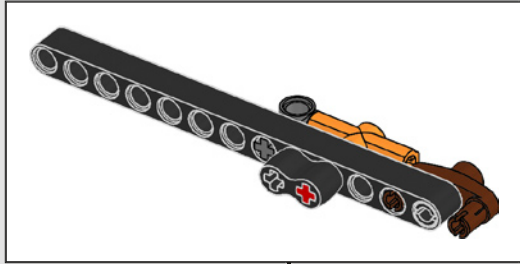

38

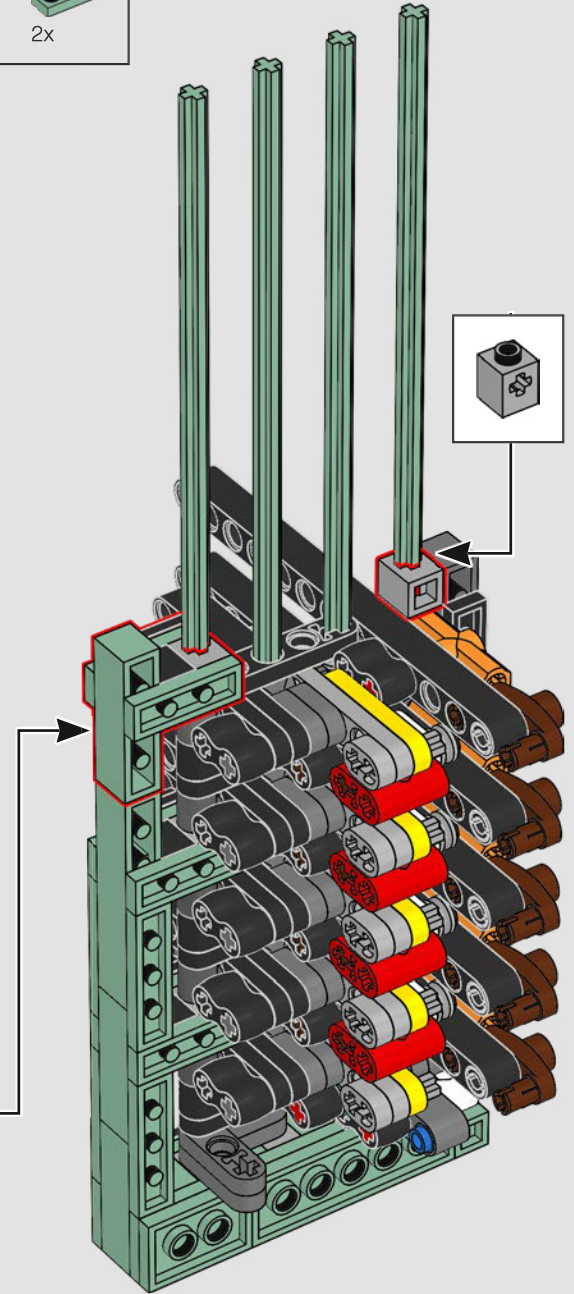
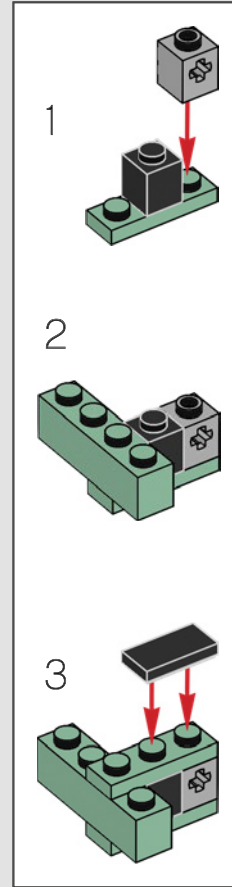

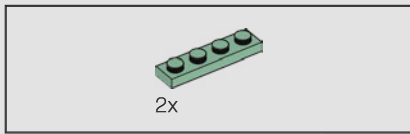

39

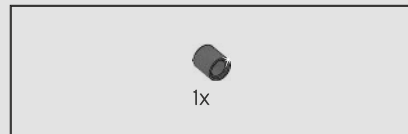
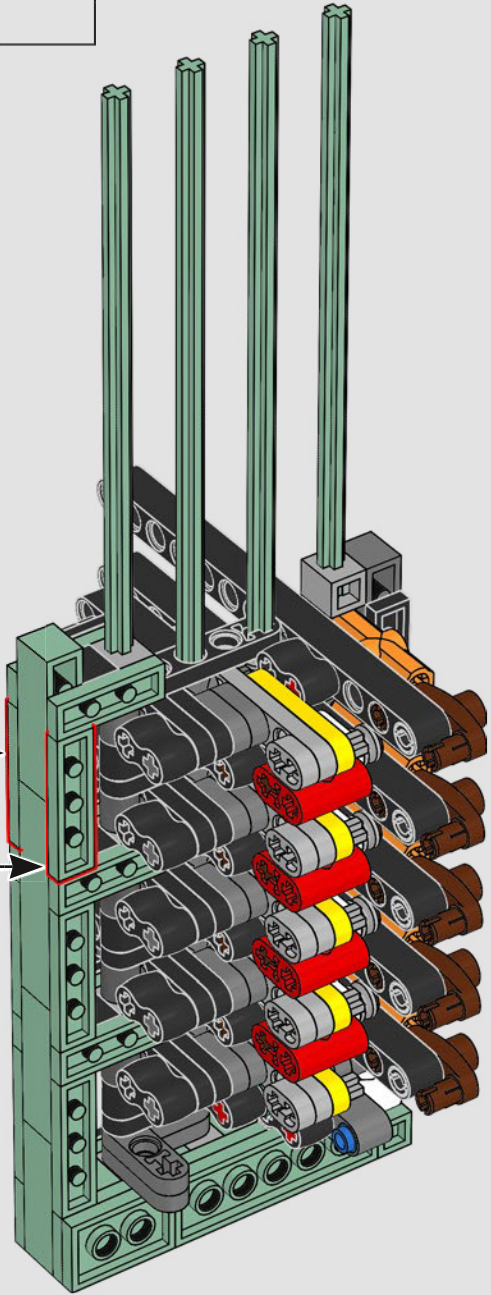
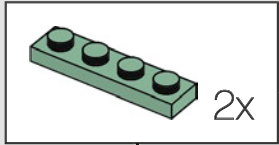

40

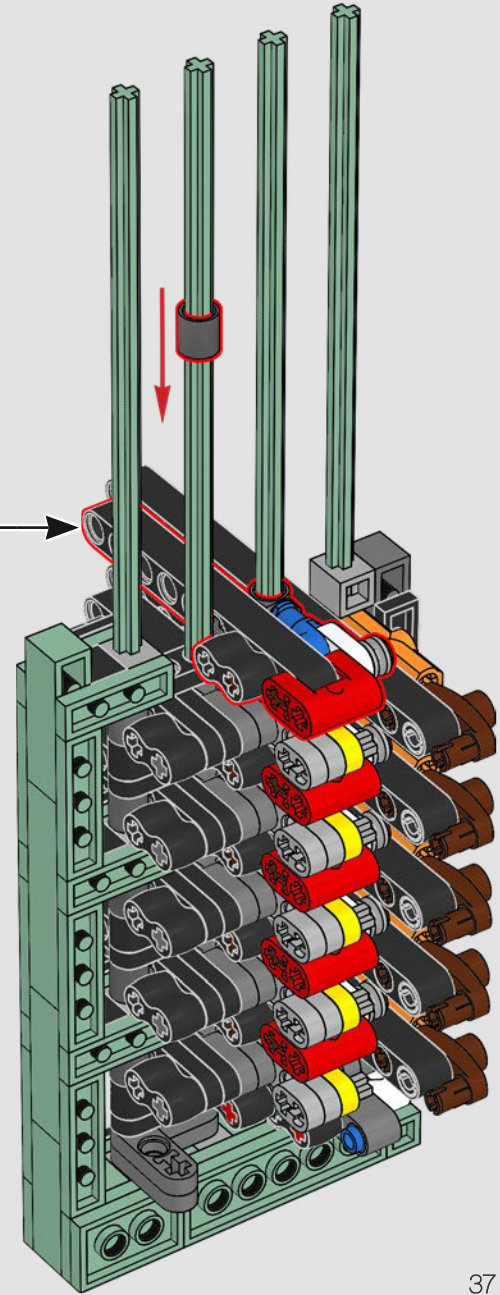
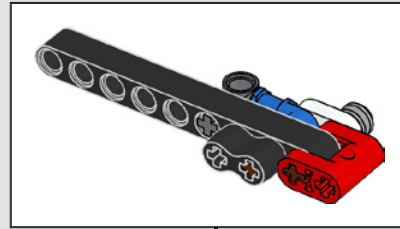

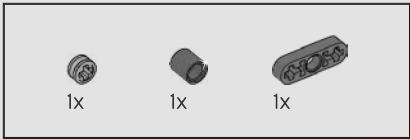

41

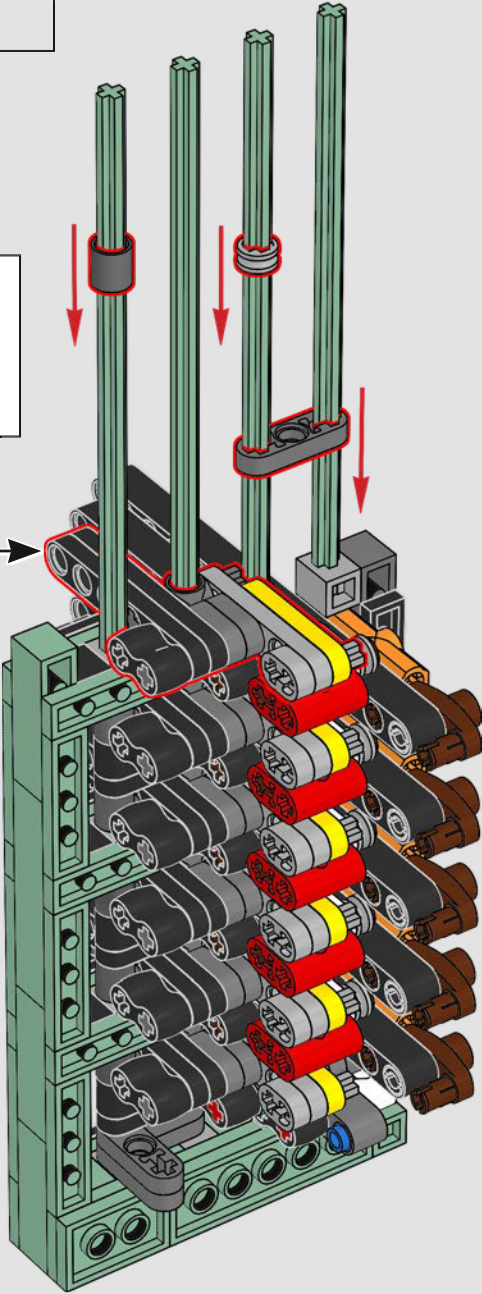
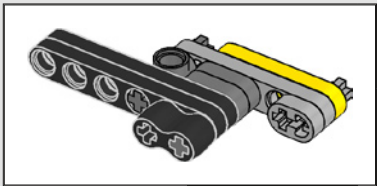

42

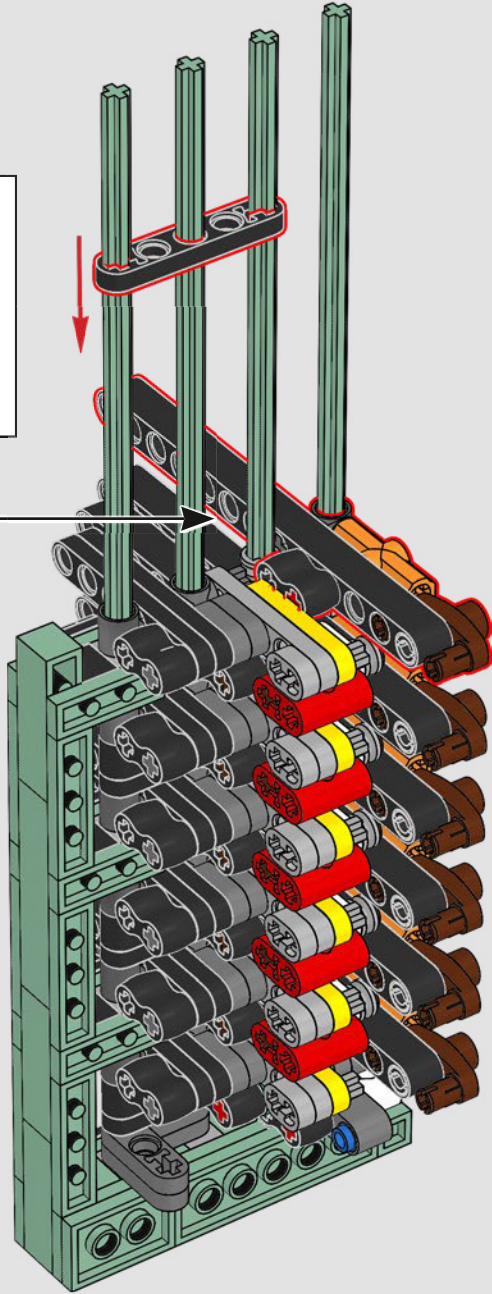
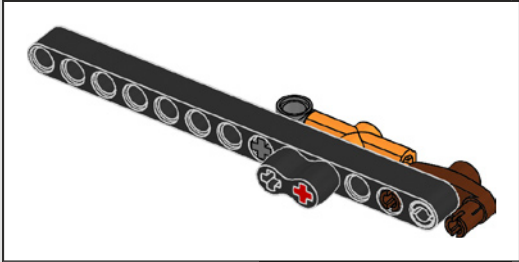

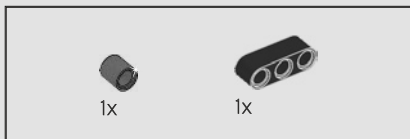

43

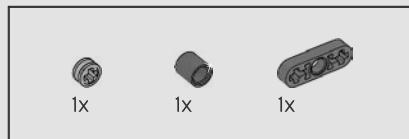
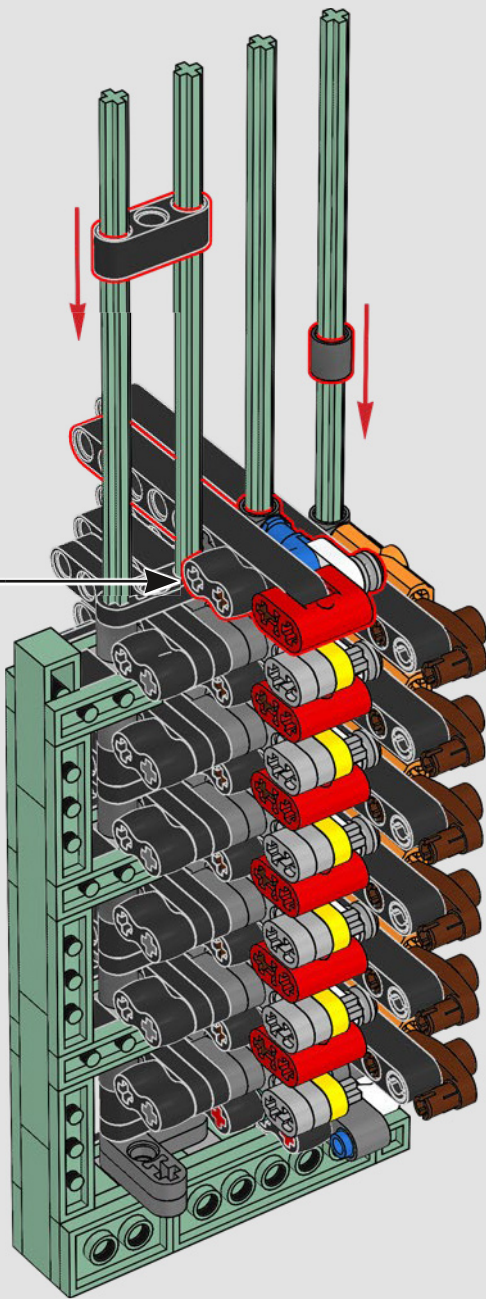
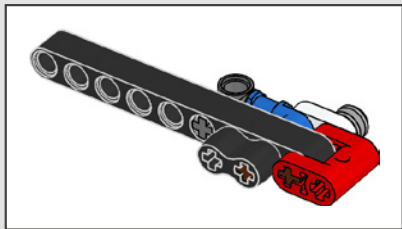

44

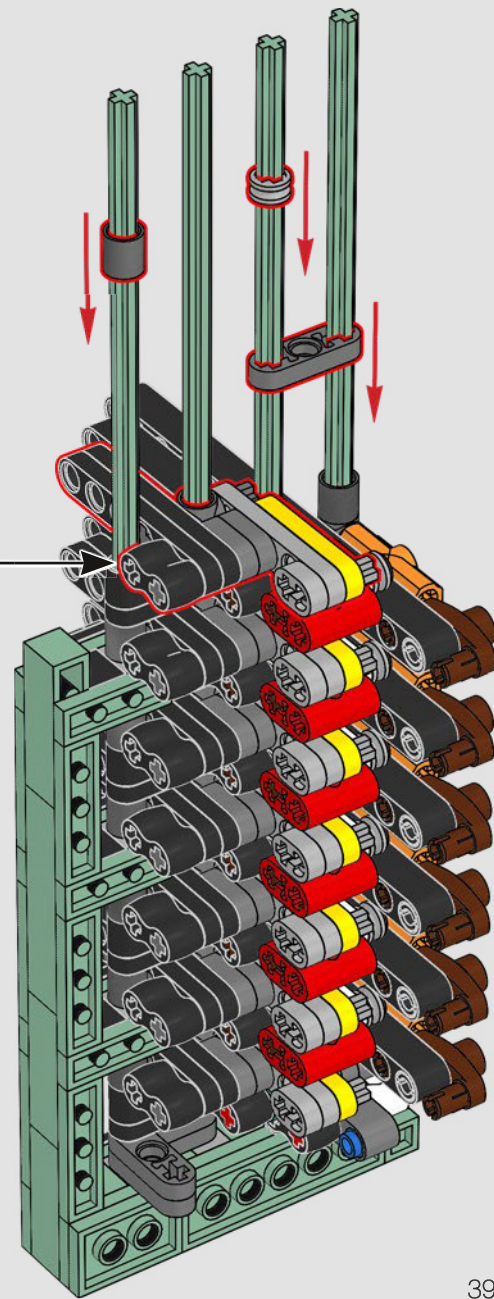
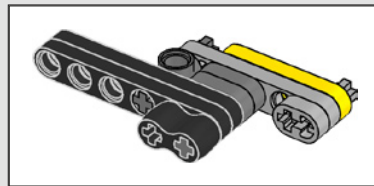

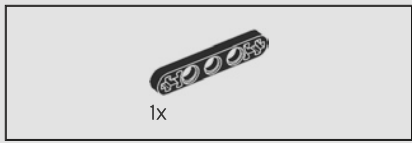

45

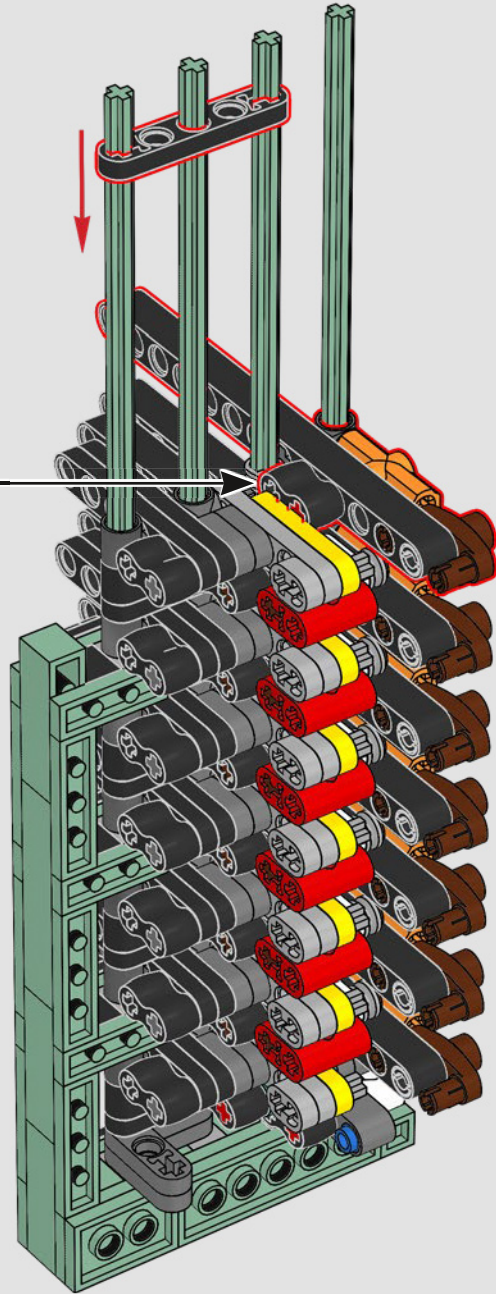
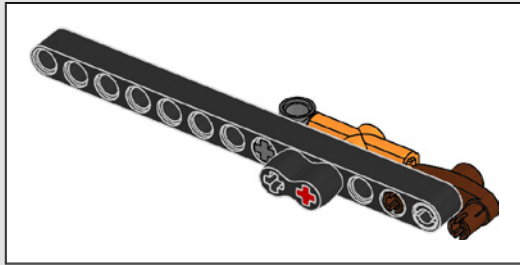

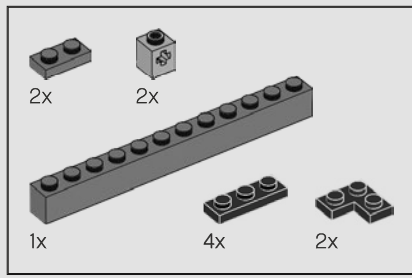

46

1

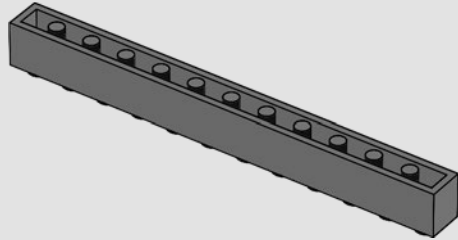

2

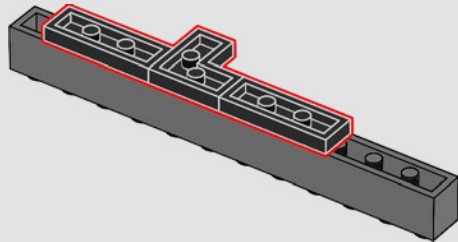

3

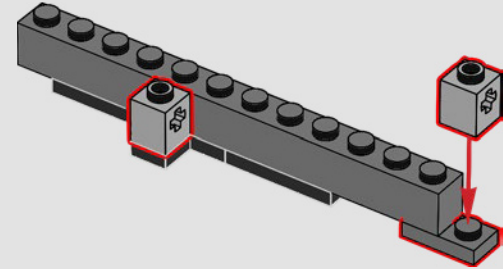

4

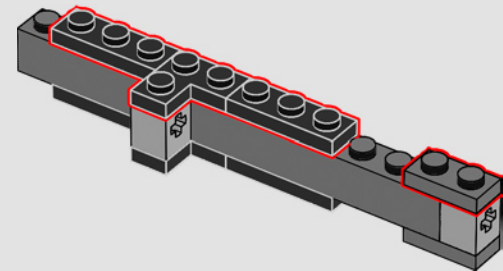

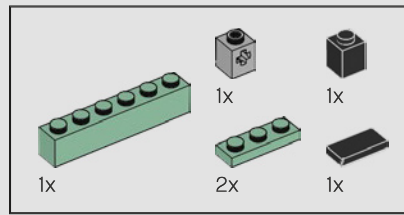
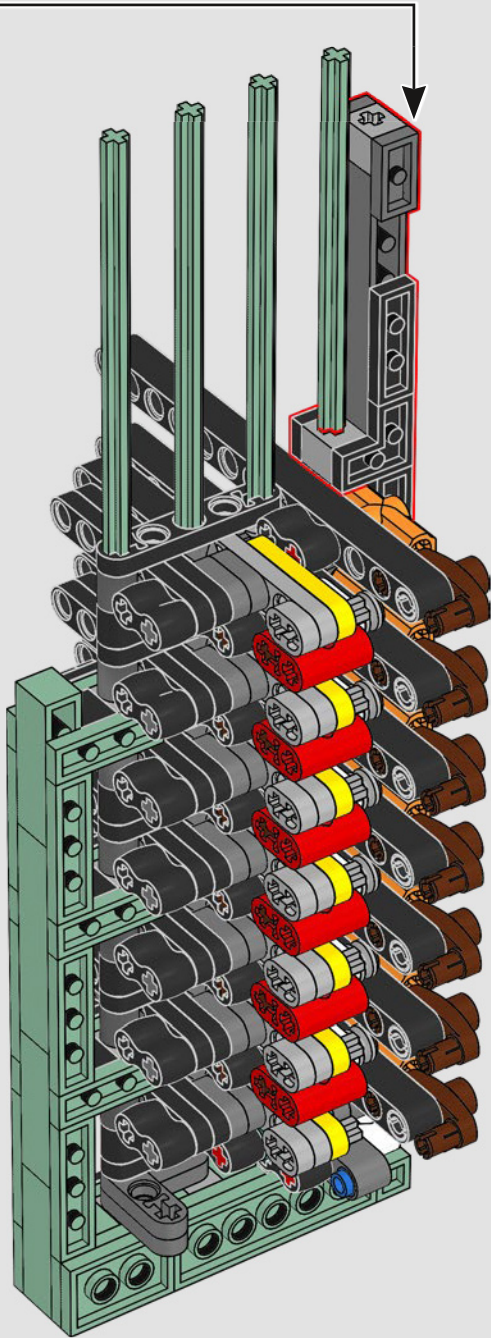

47

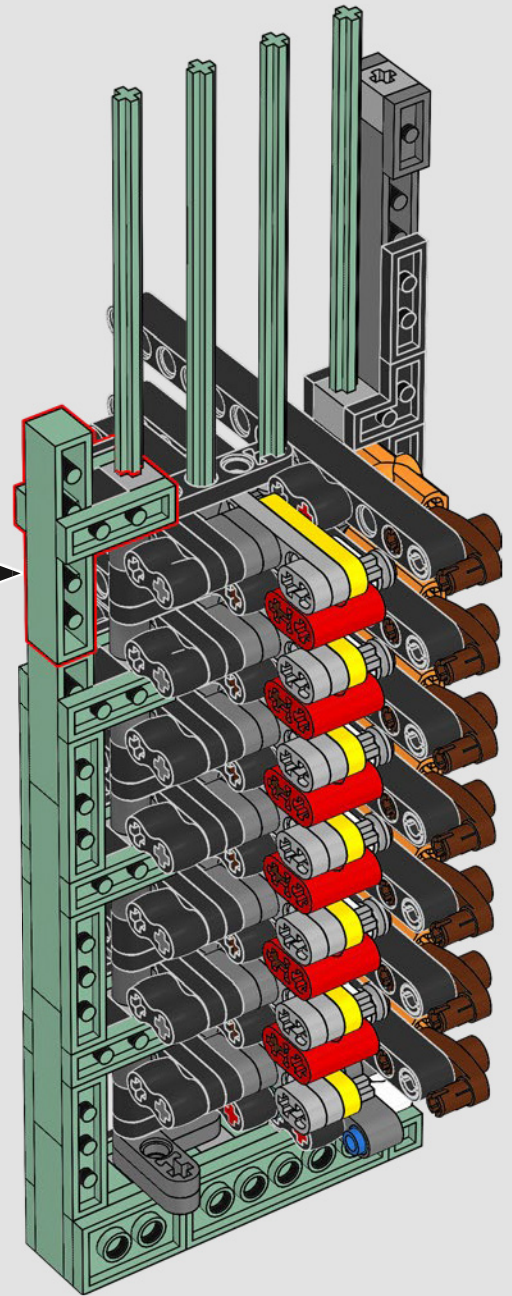
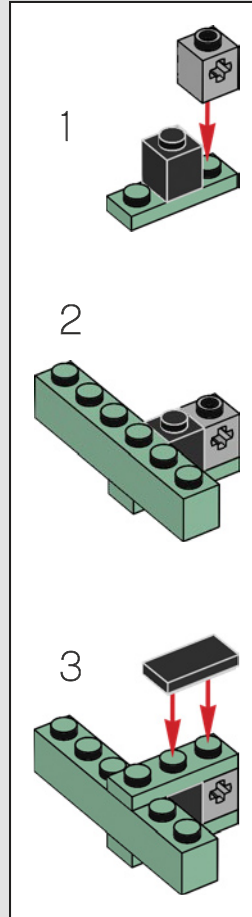



48

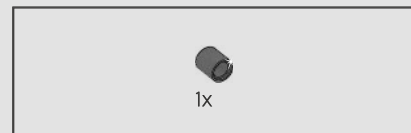
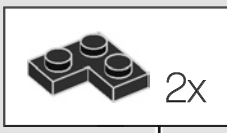
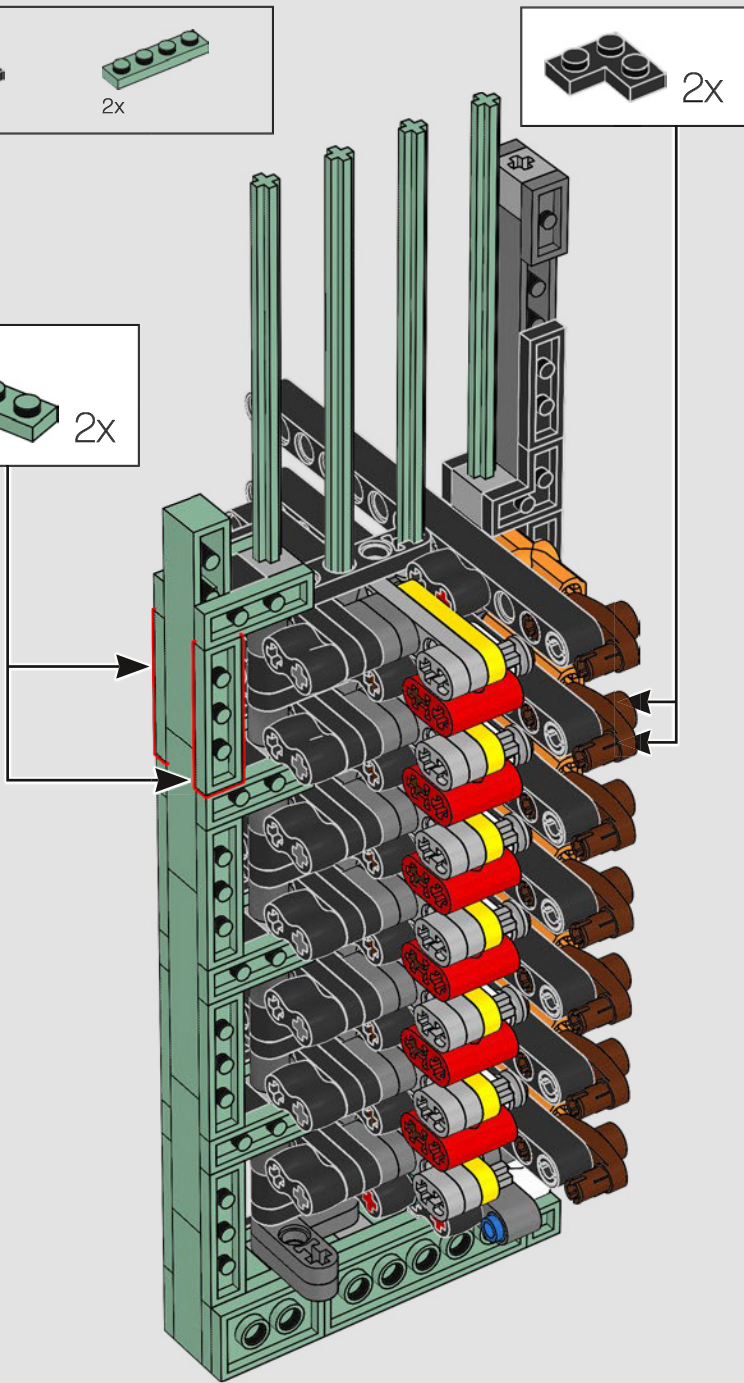
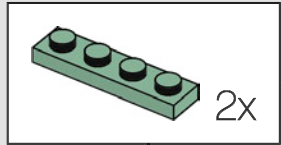

49

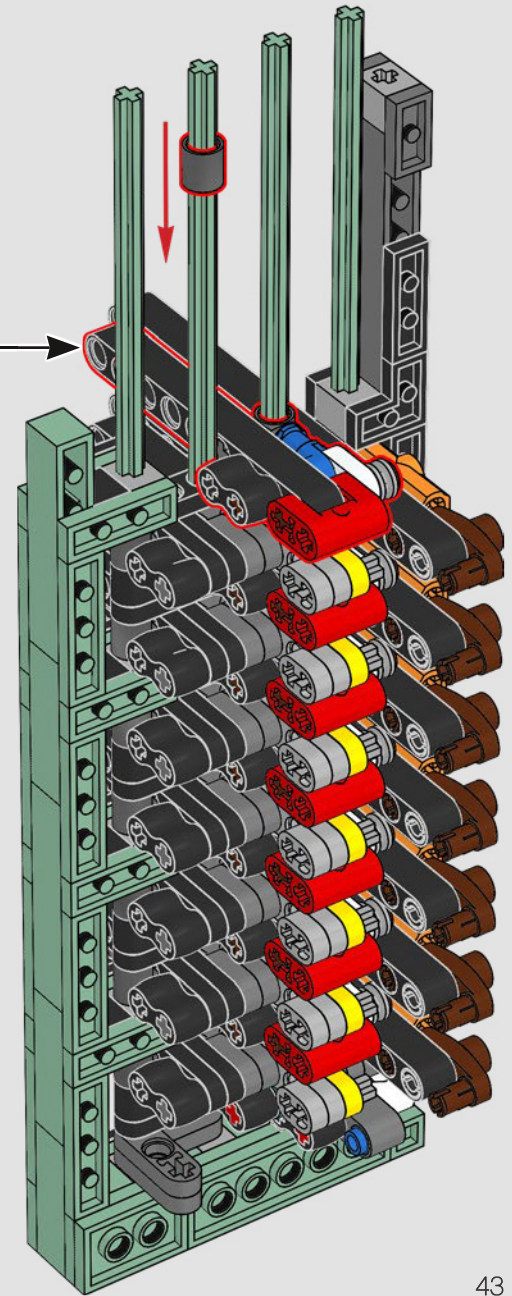
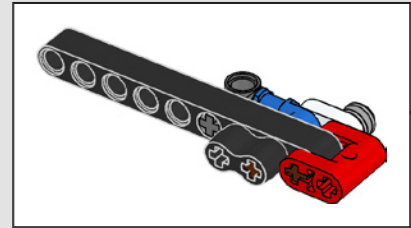

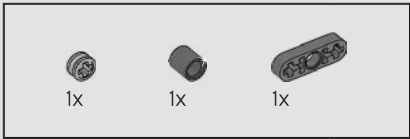

50

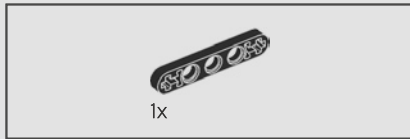
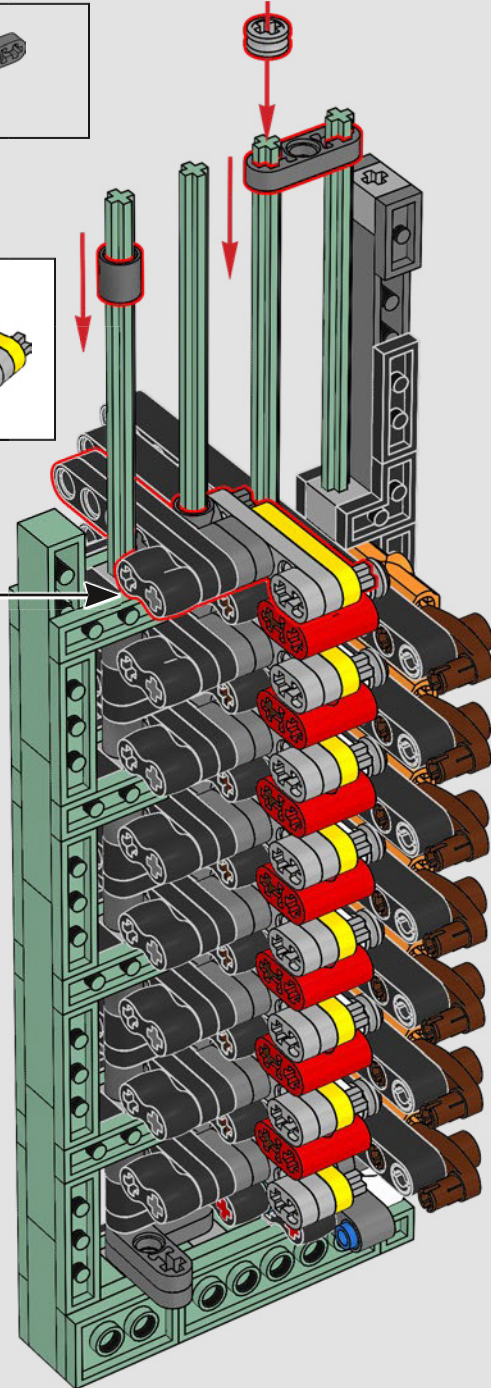
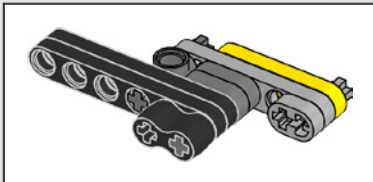

51

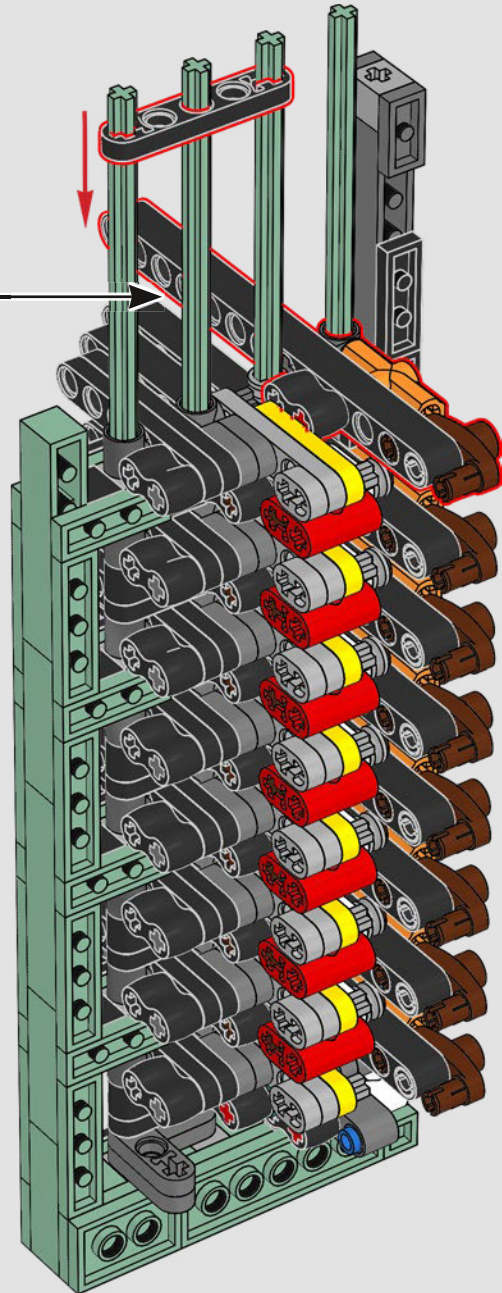
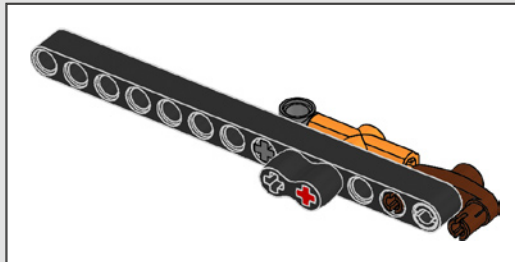

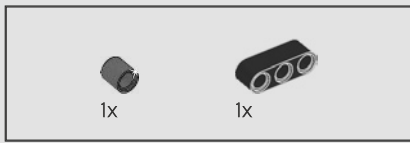

52

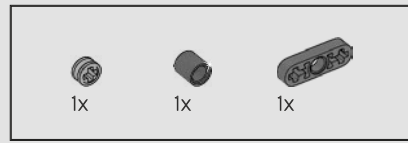
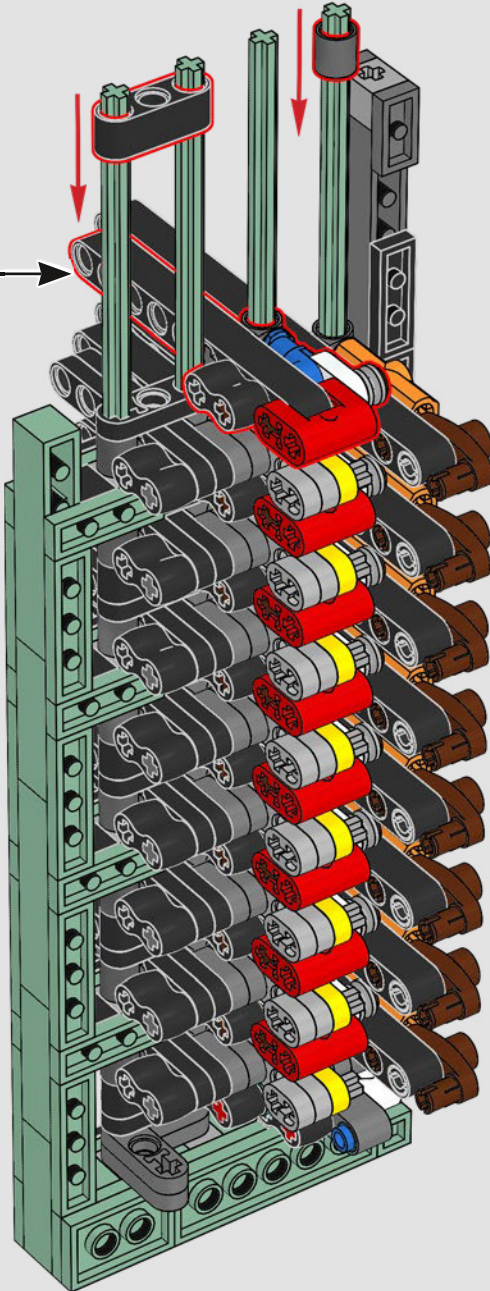
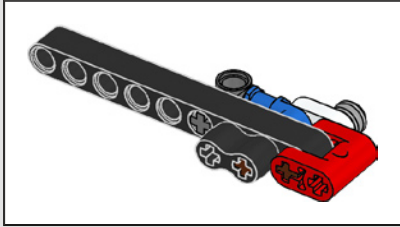

53

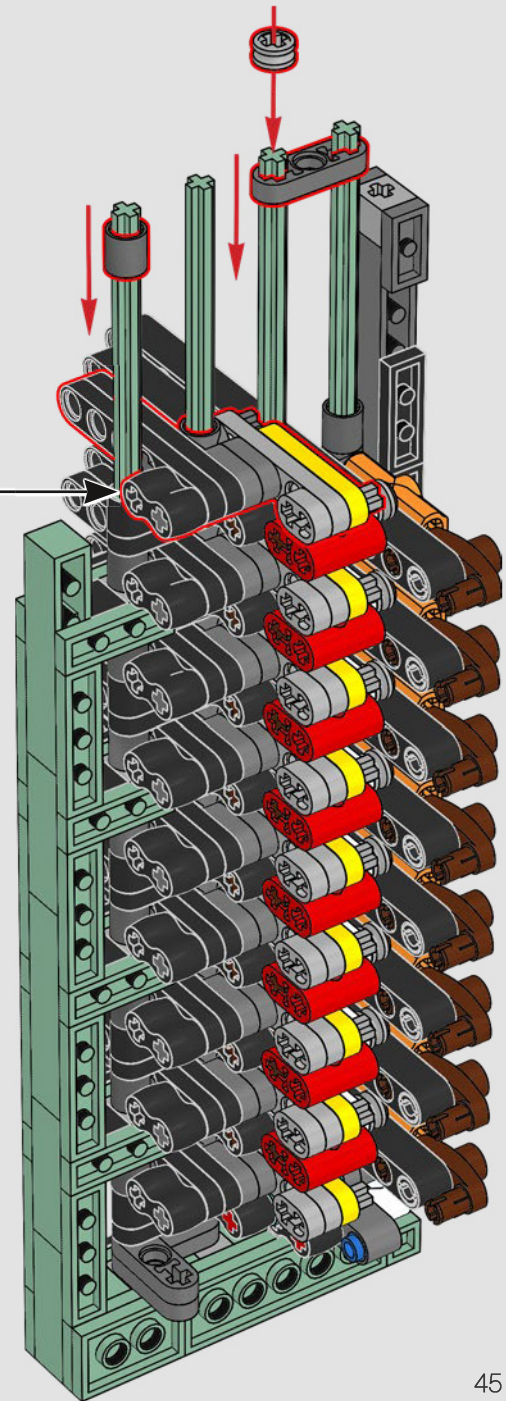
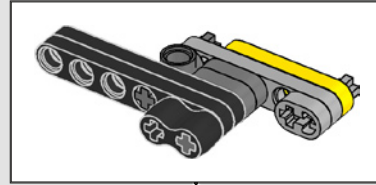

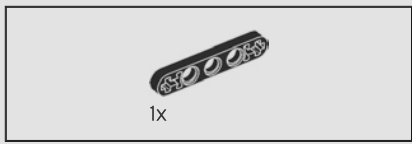

54

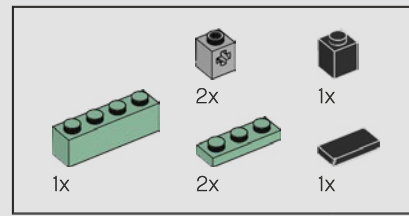
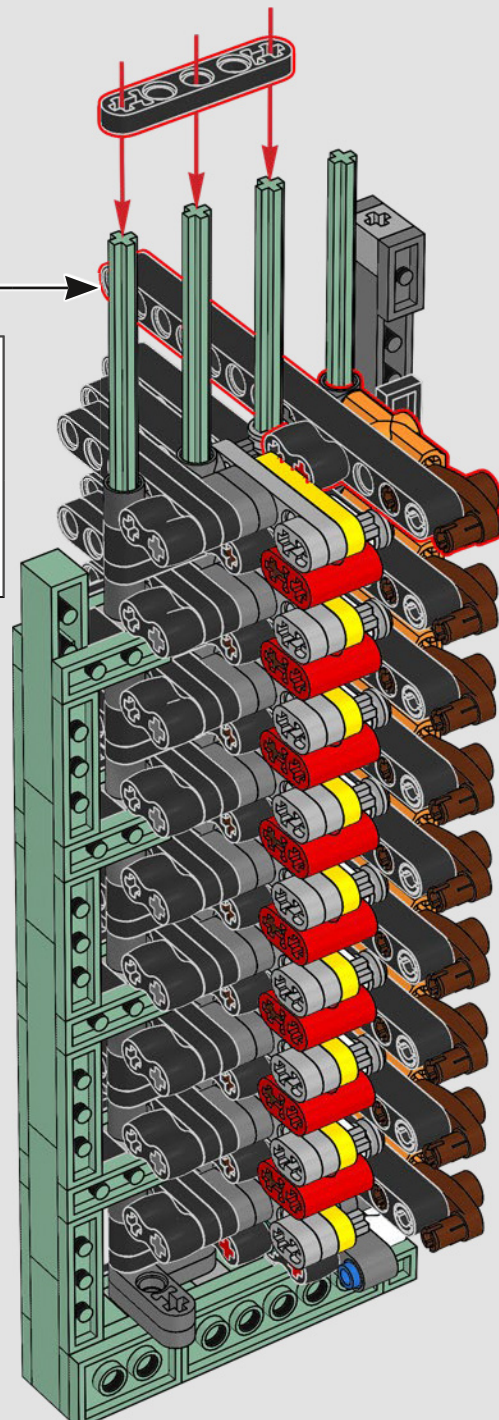
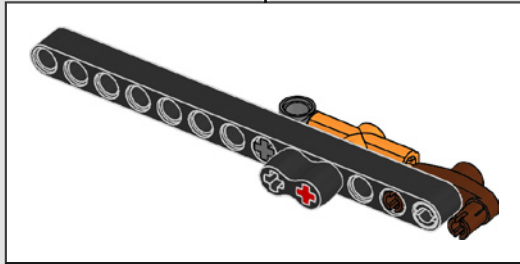

55

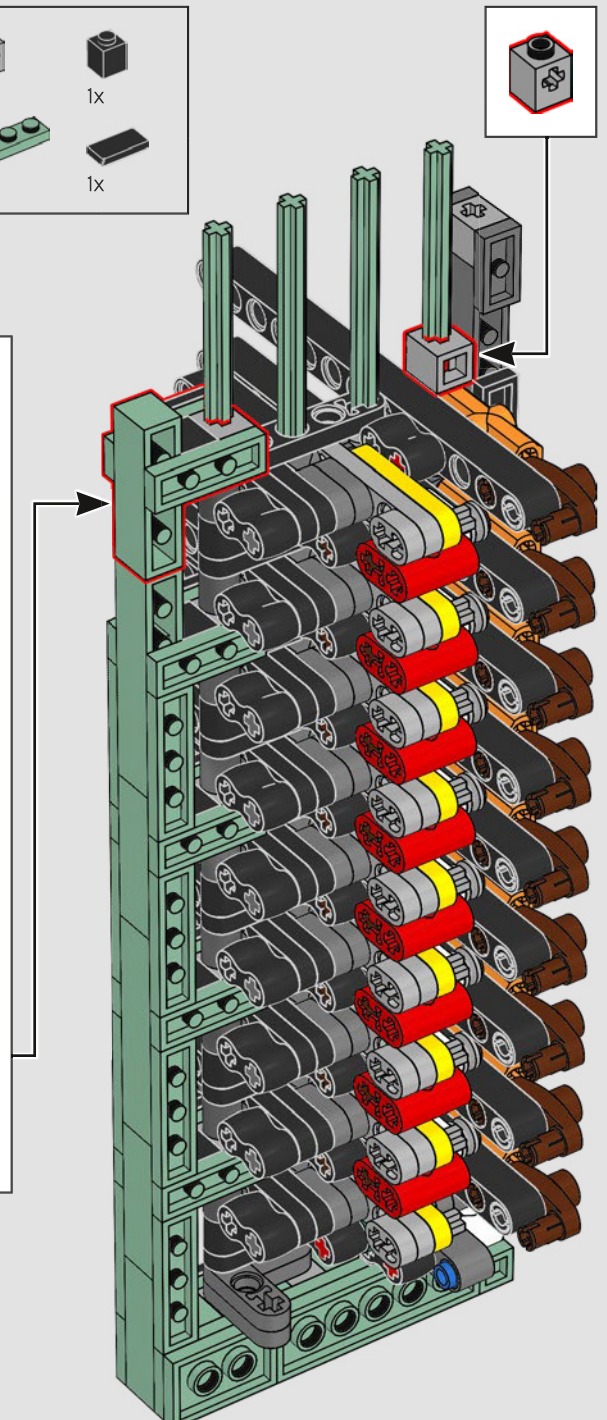
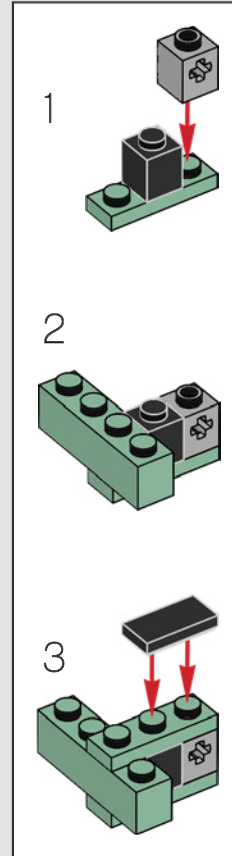

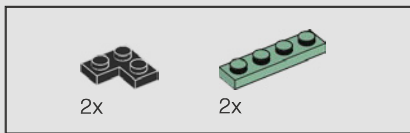

56

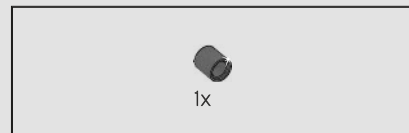
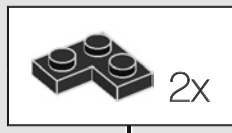
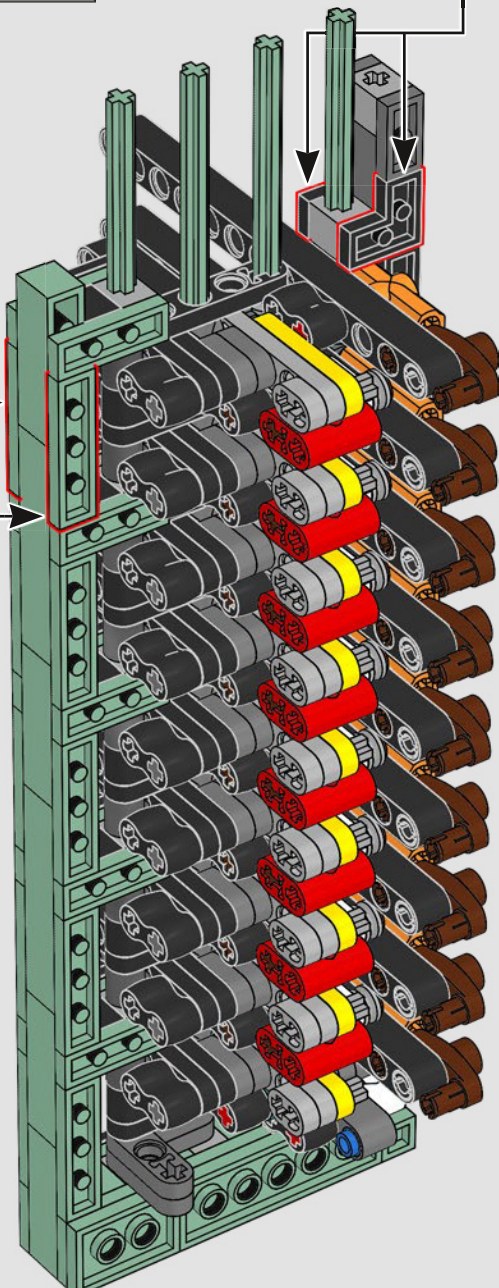
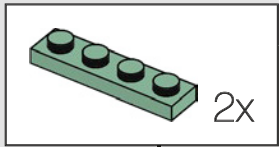

57

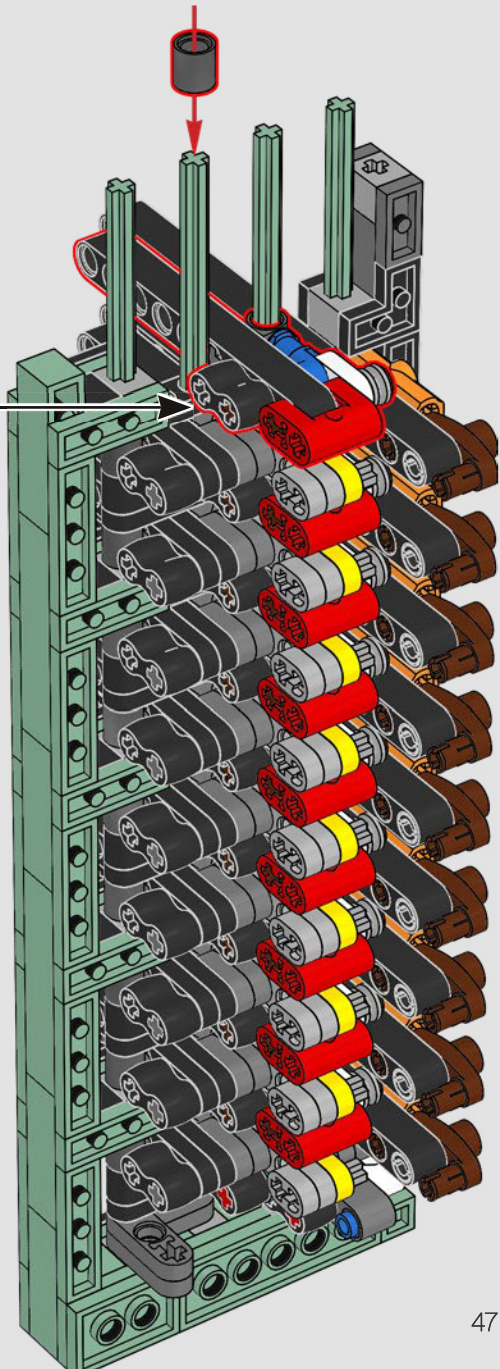
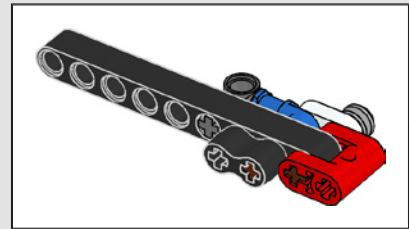

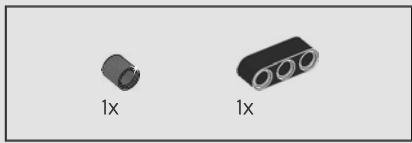

58

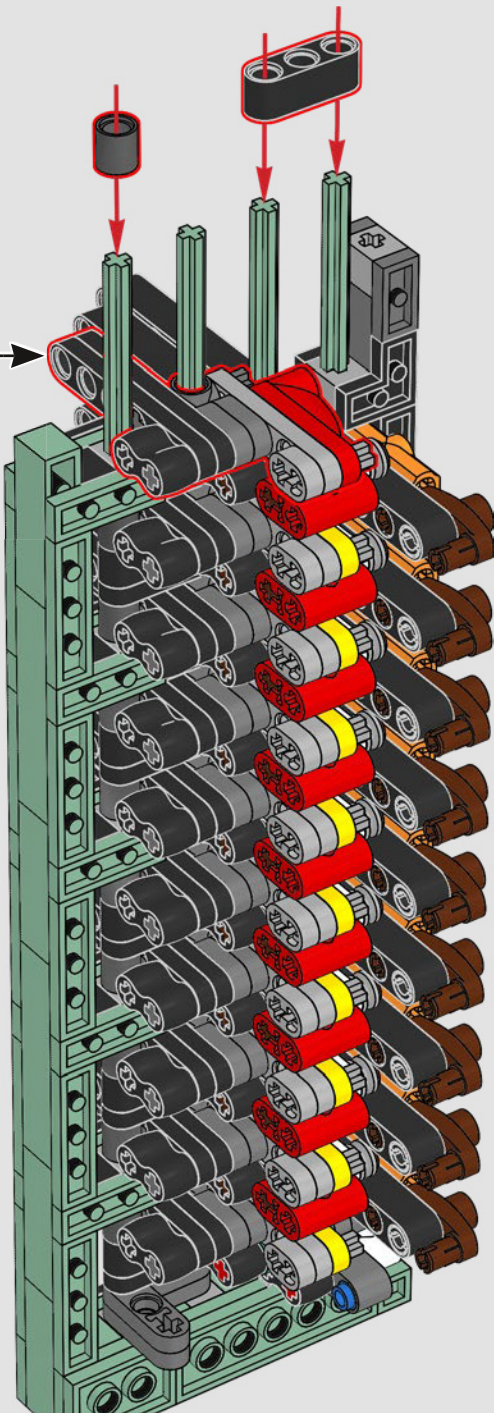
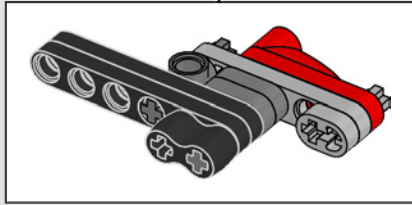

59

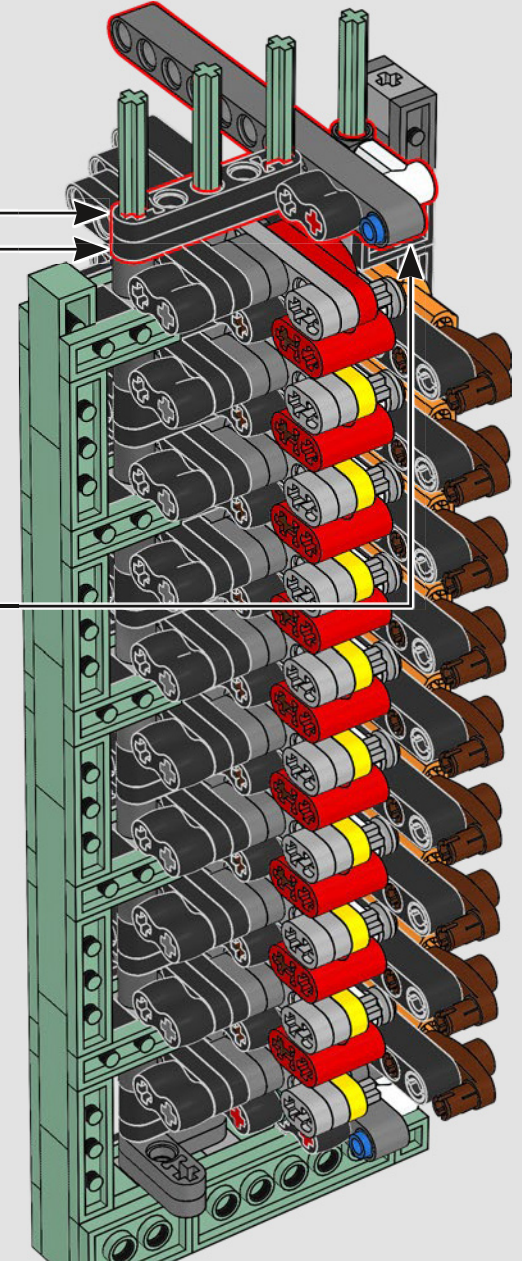
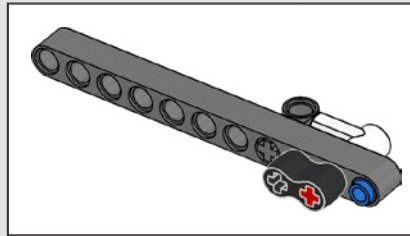
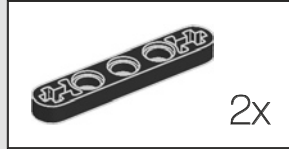

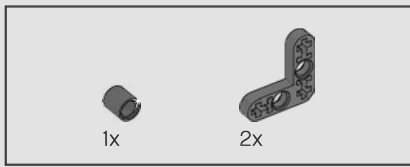

60

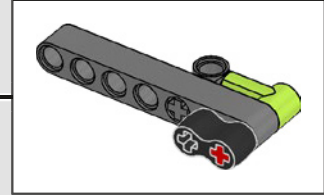
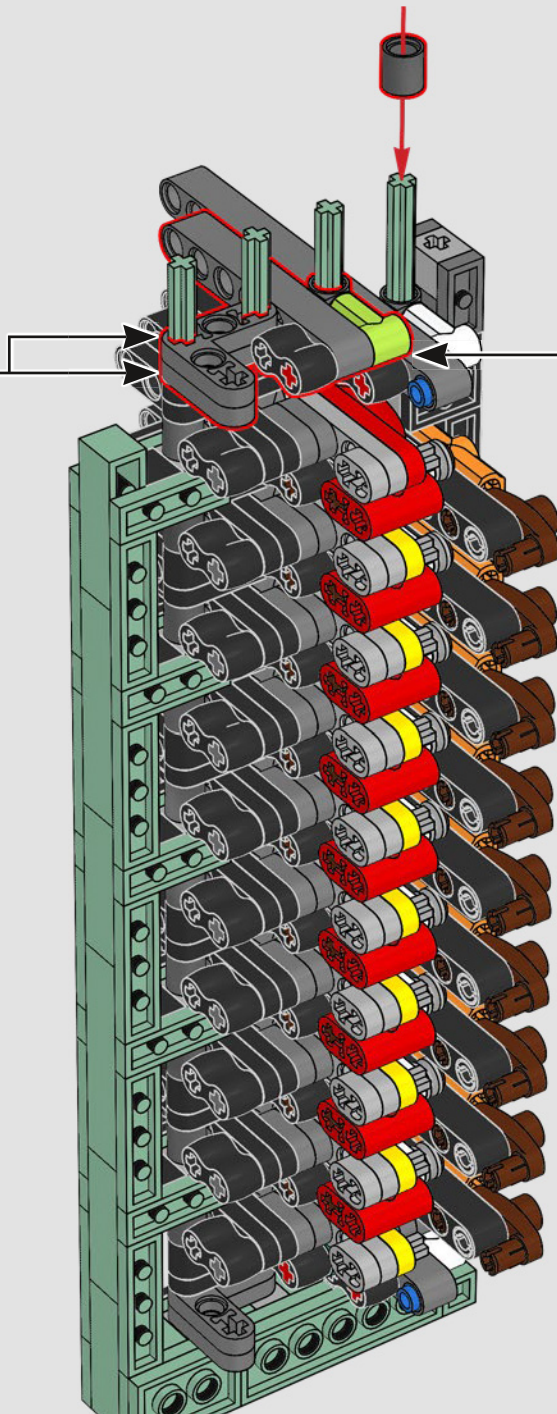
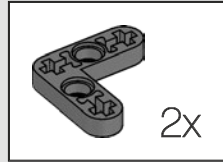

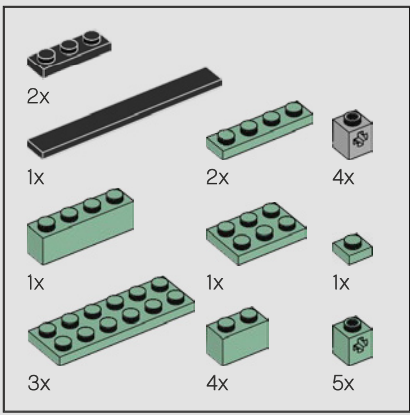

61

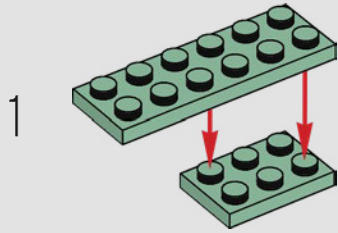

2

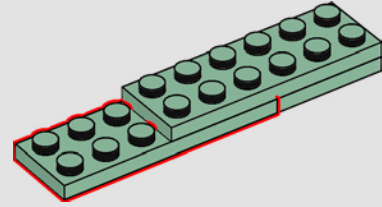

3

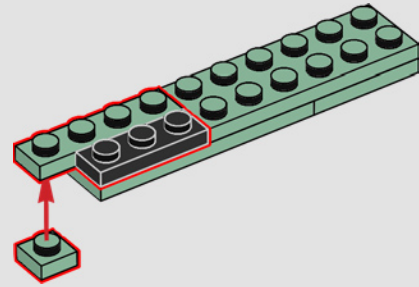

4

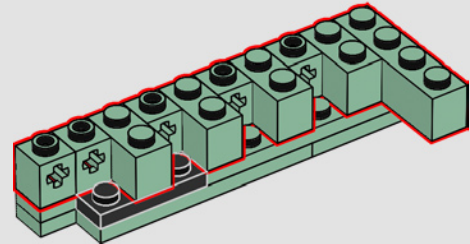

5

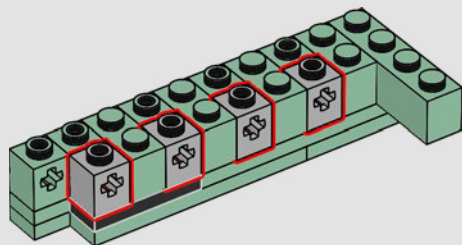

6

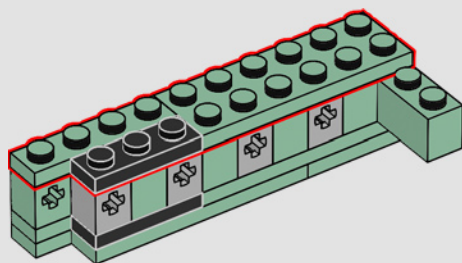

7

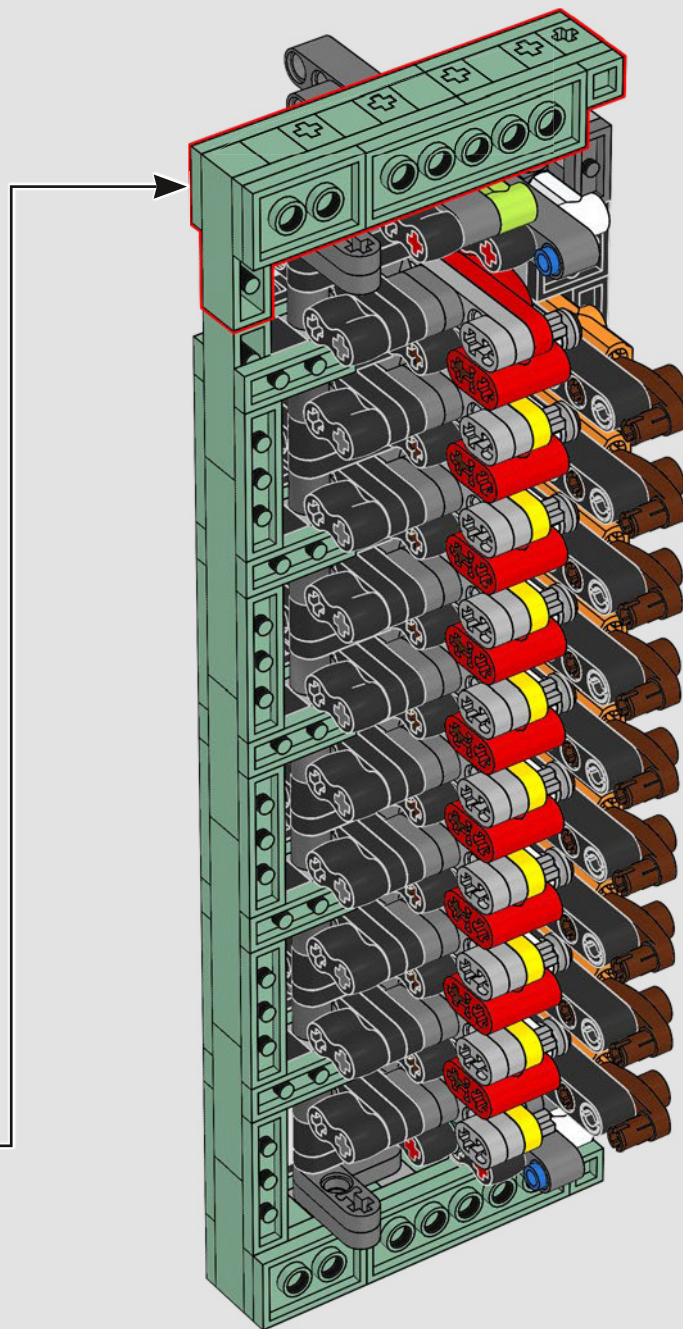
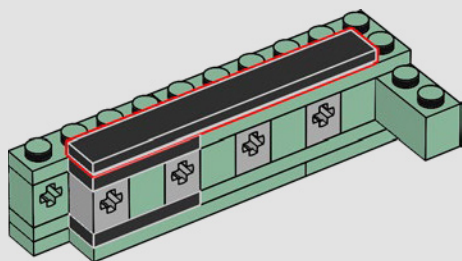

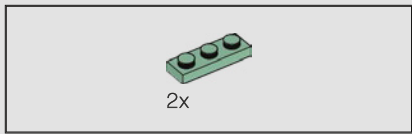

62

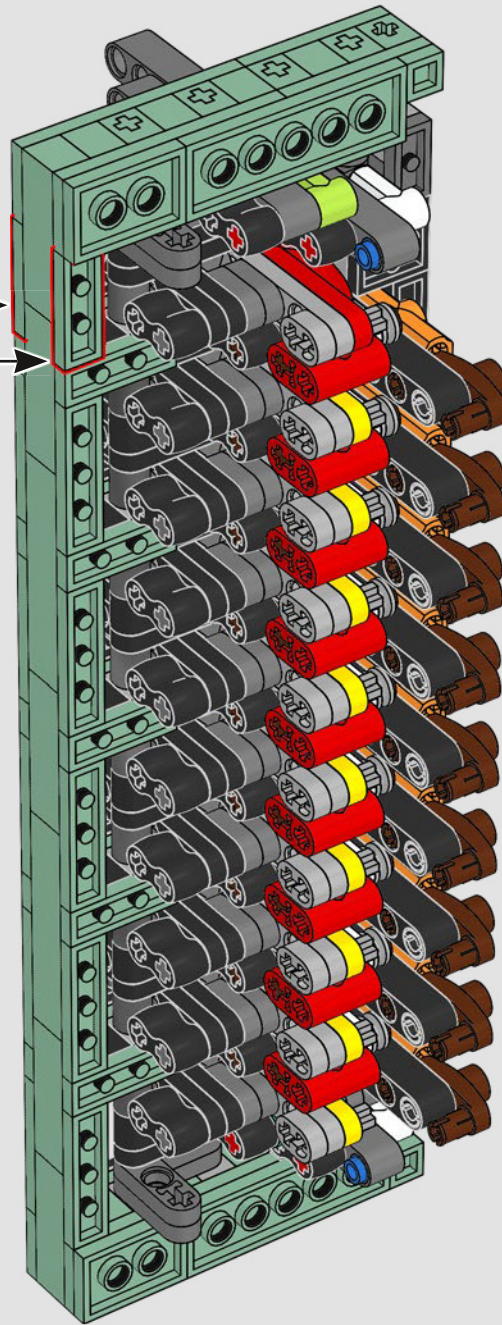
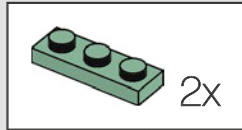

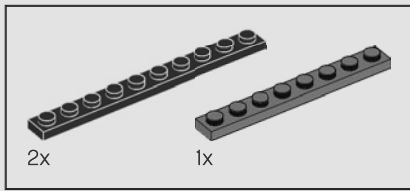

63

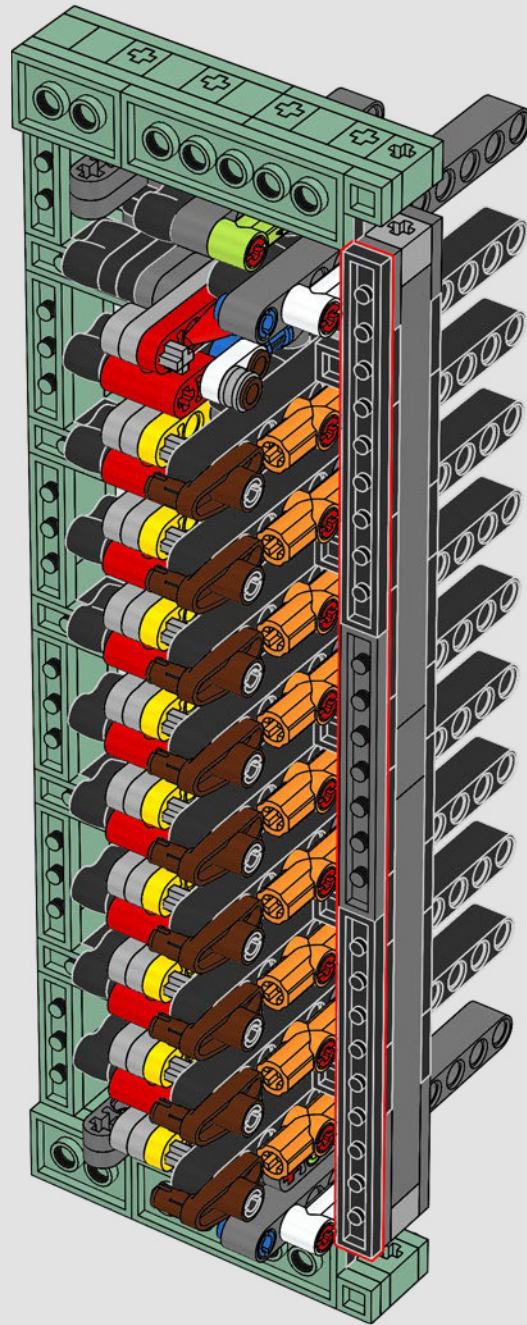

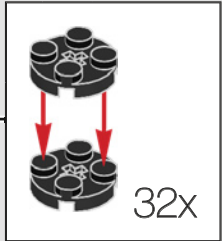
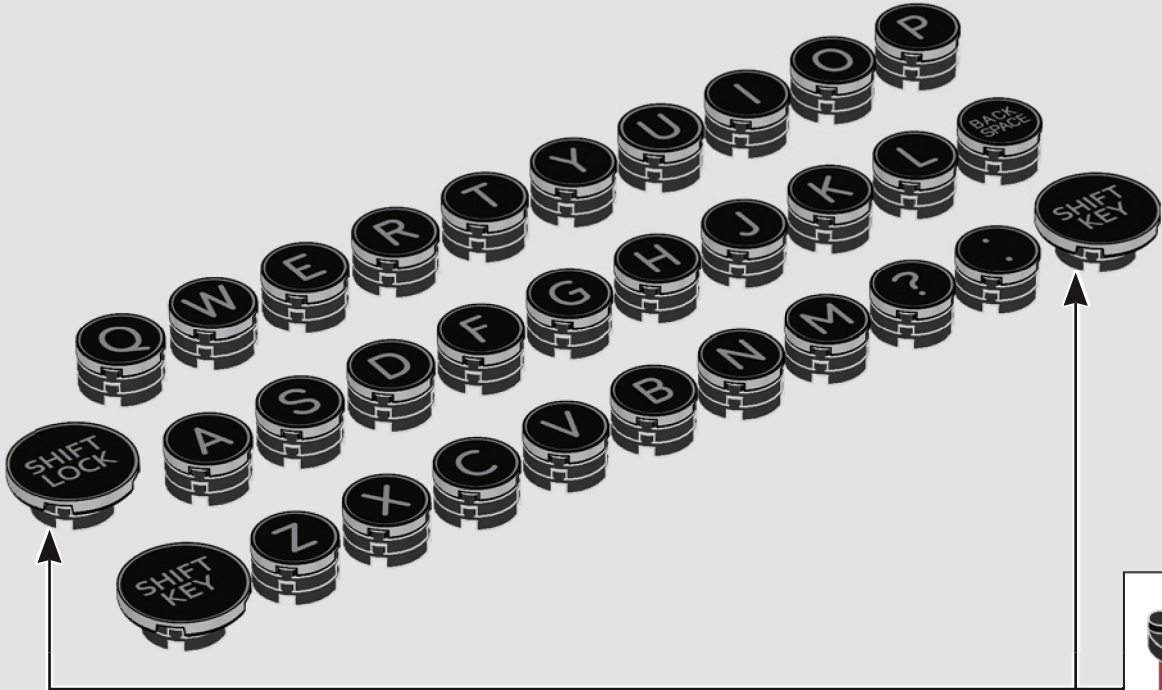
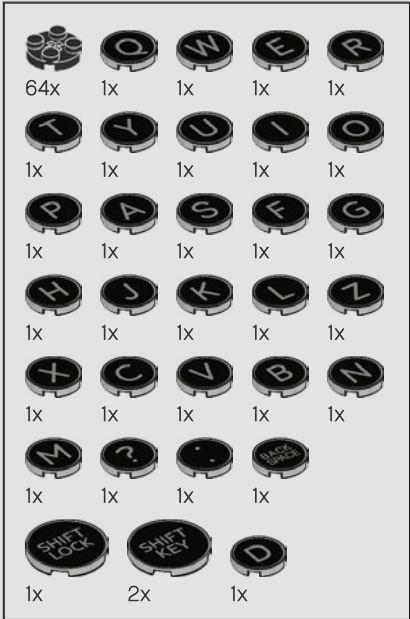
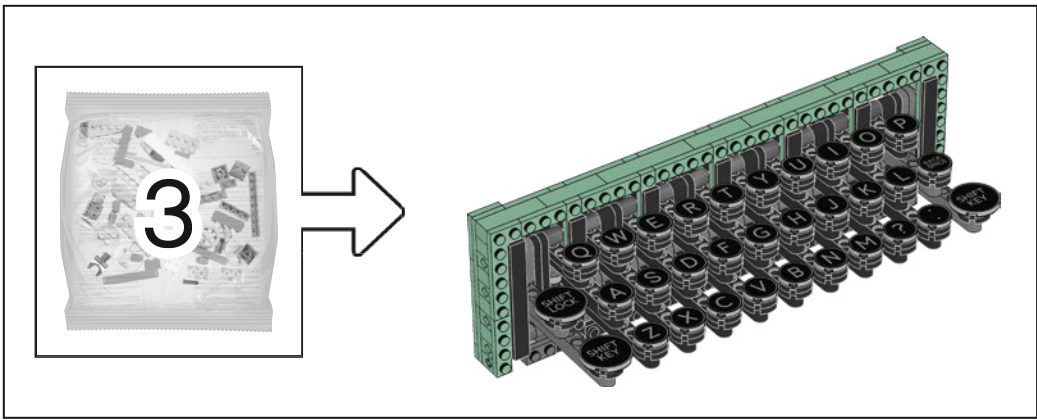

64

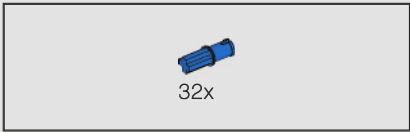

65

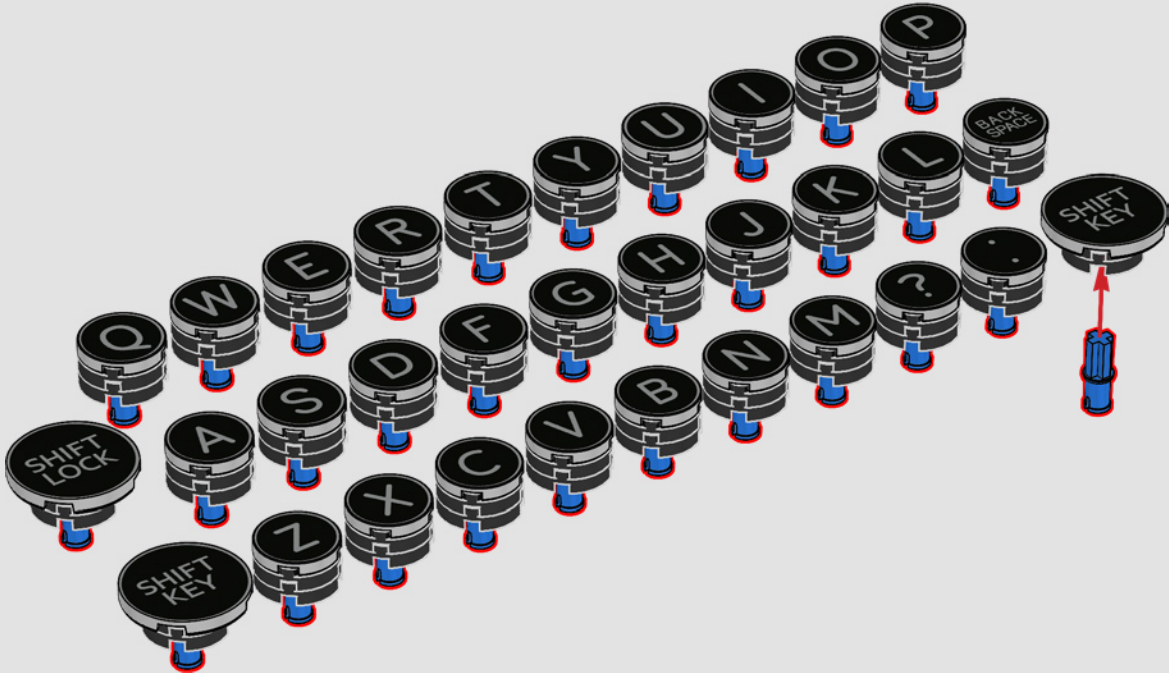

66

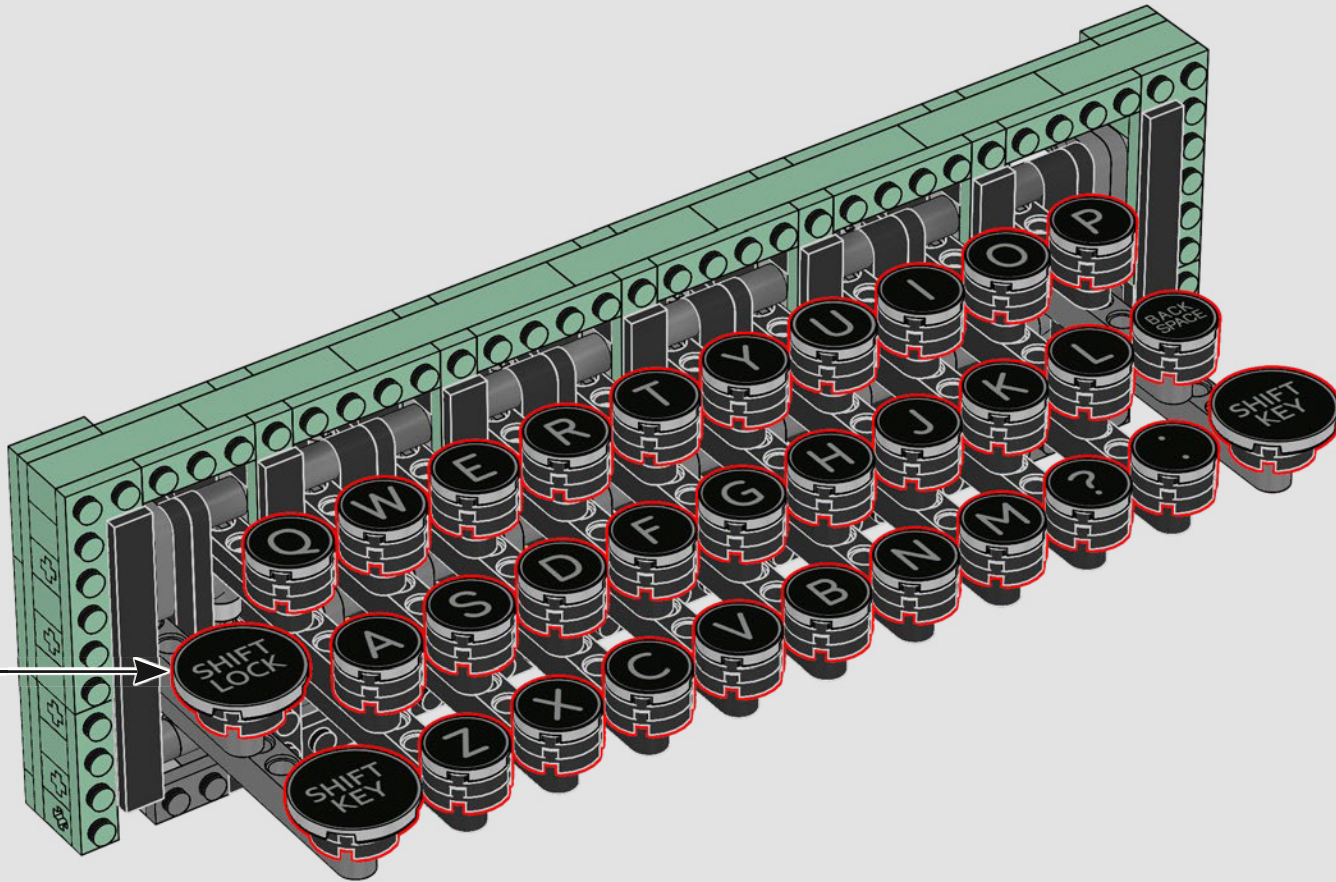

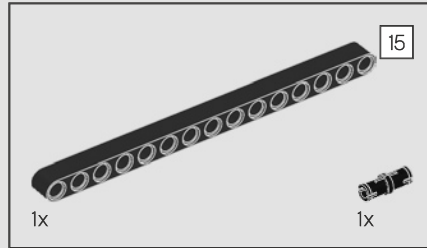
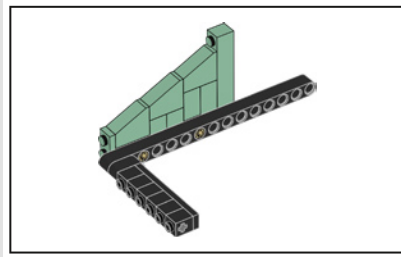
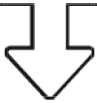

67

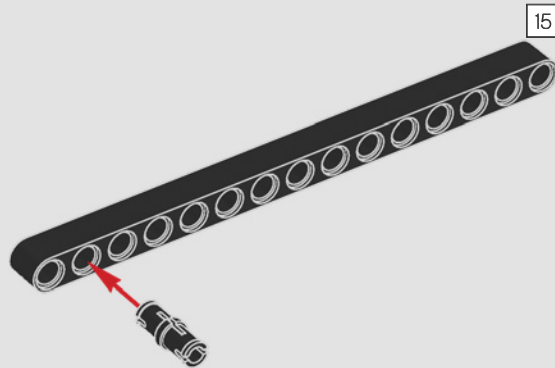

68



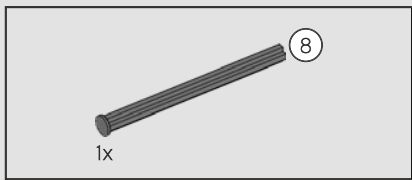

69

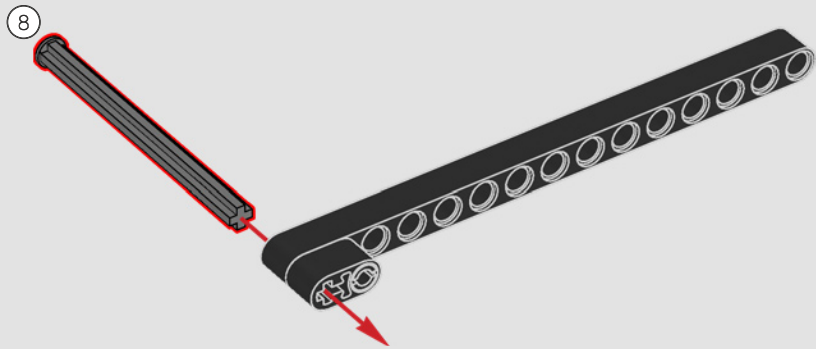

70

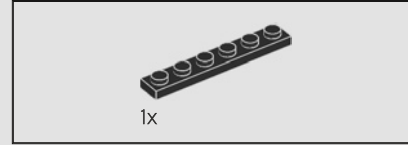
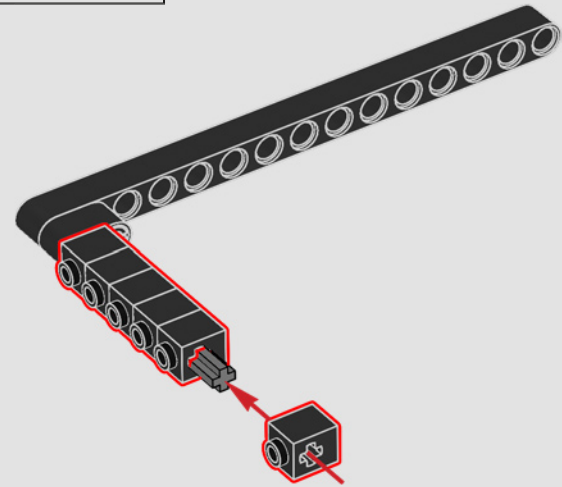

71

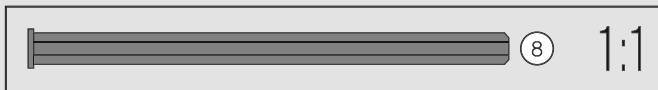
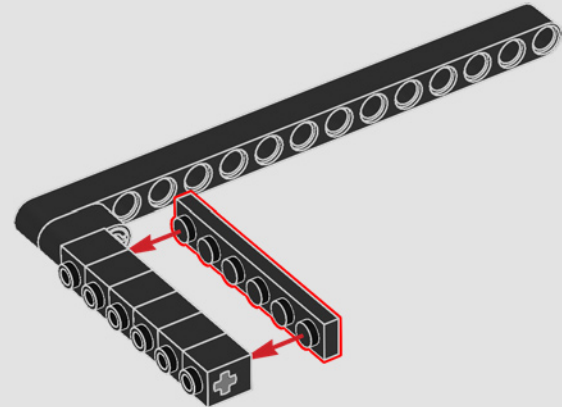

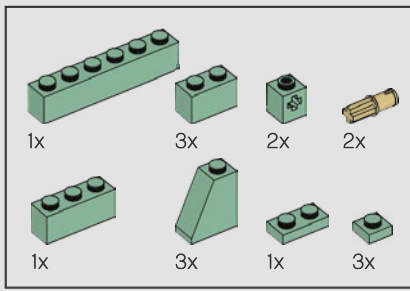

72

1

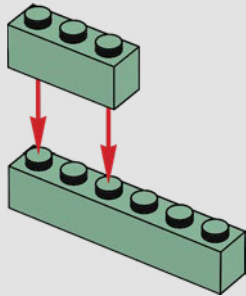

2

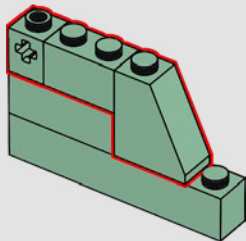

3

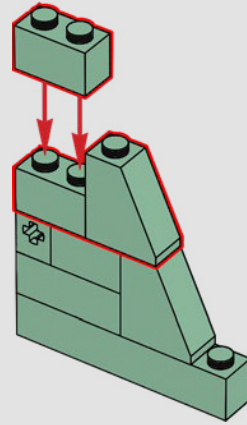

4

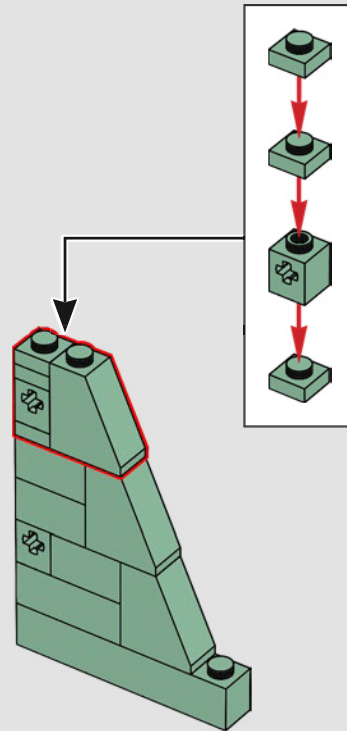

5

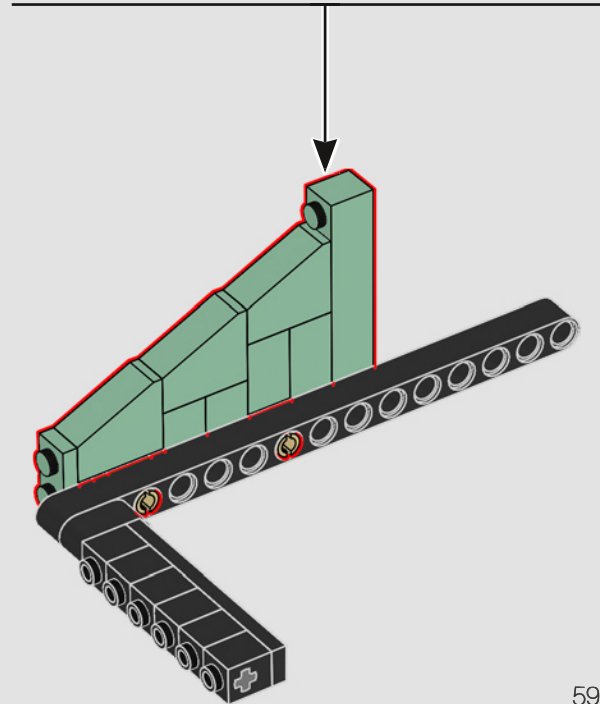
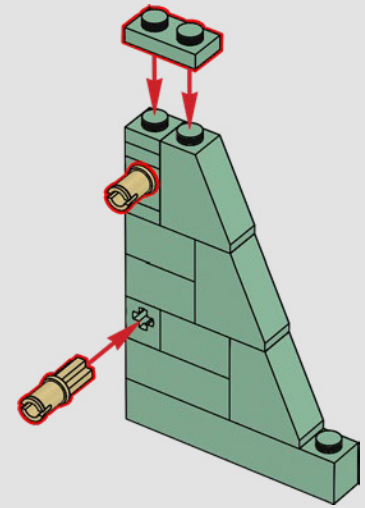

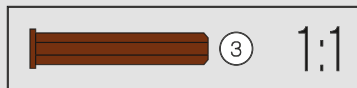
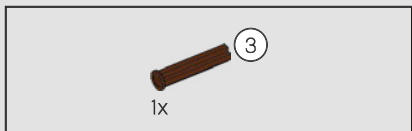

73

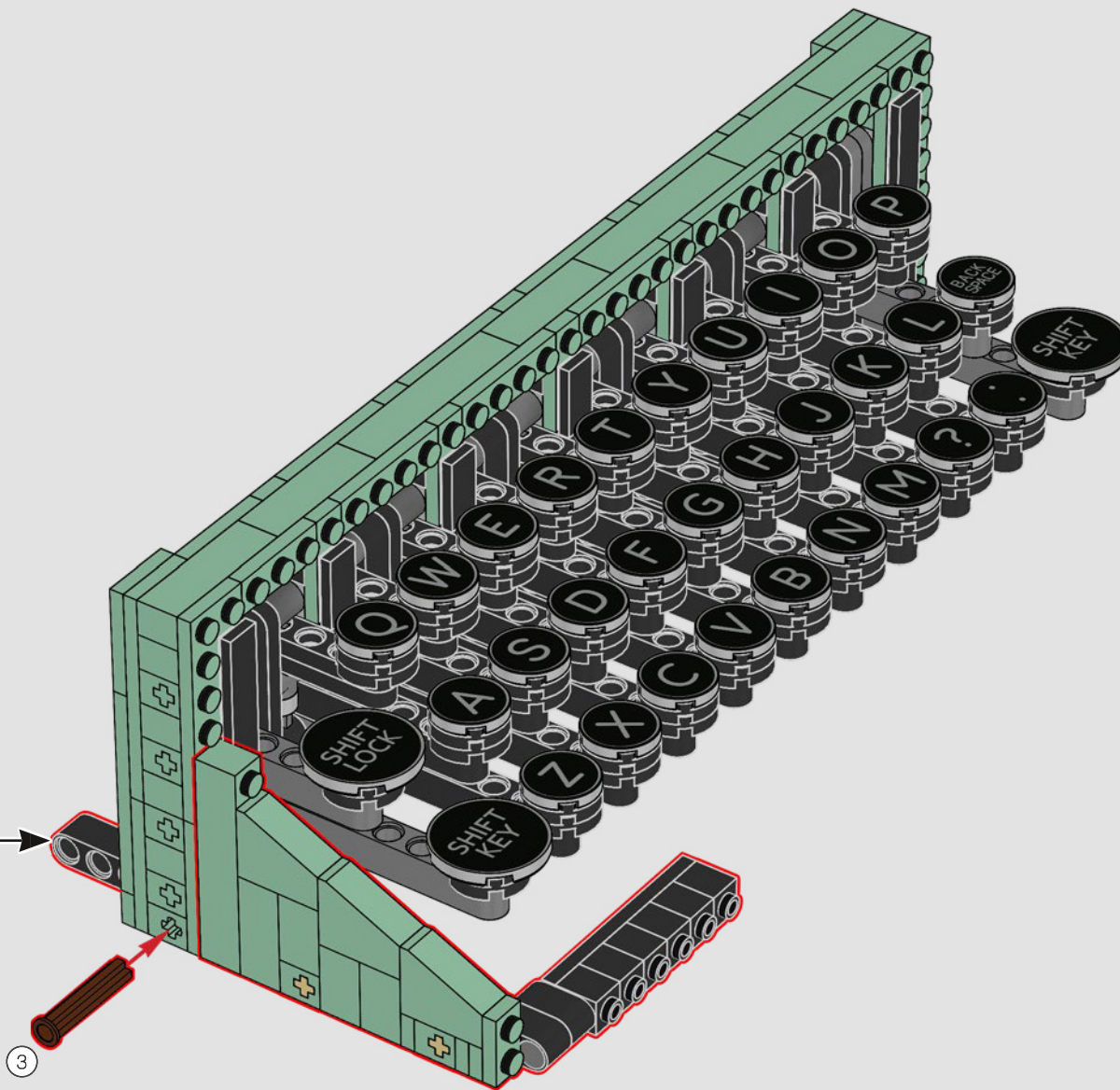

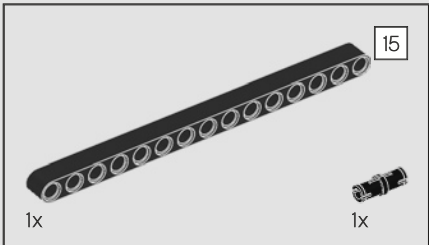
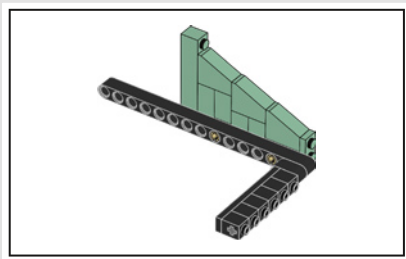

74

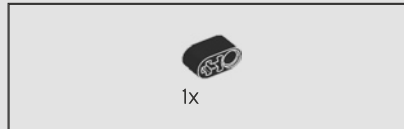
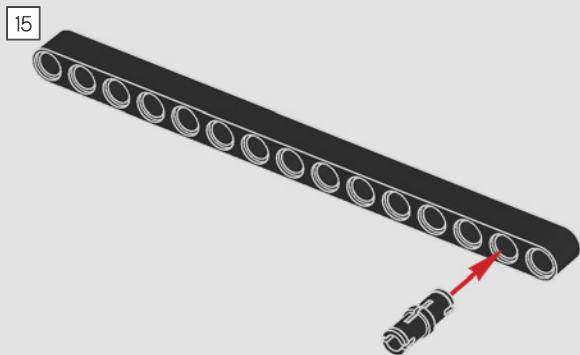

75

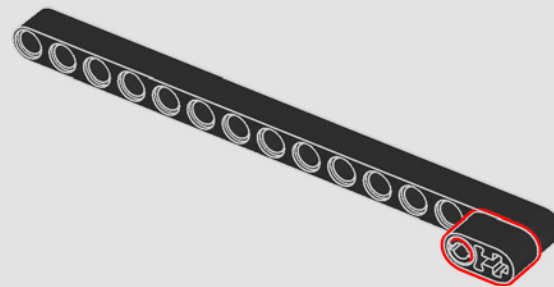

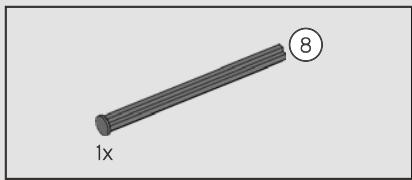

76

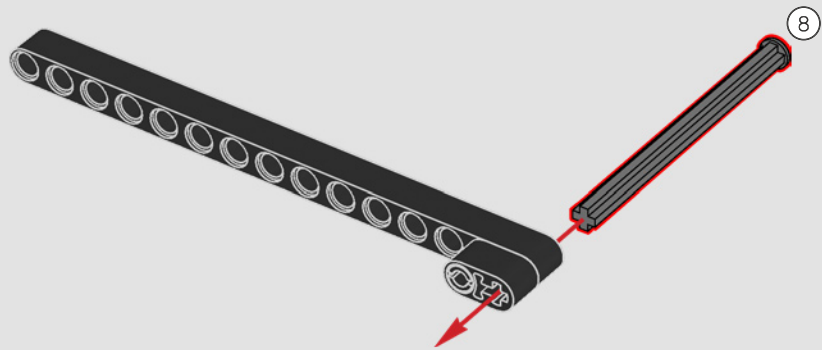

77

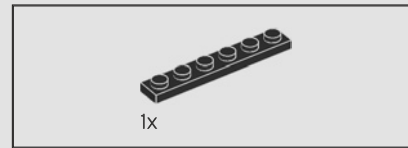
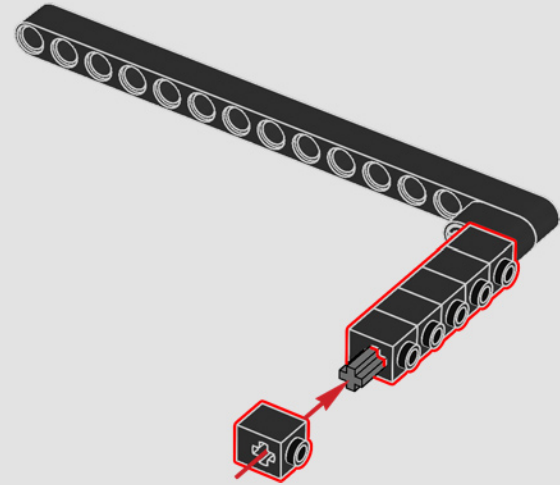

78

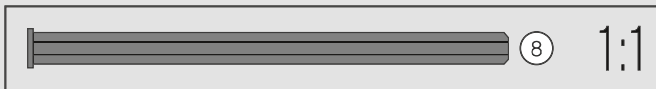
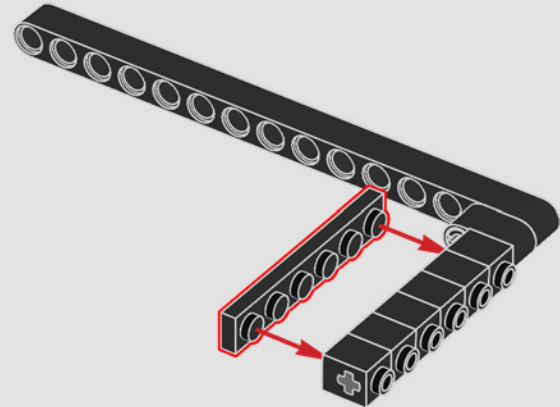

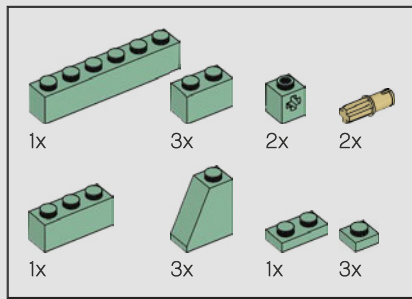

79

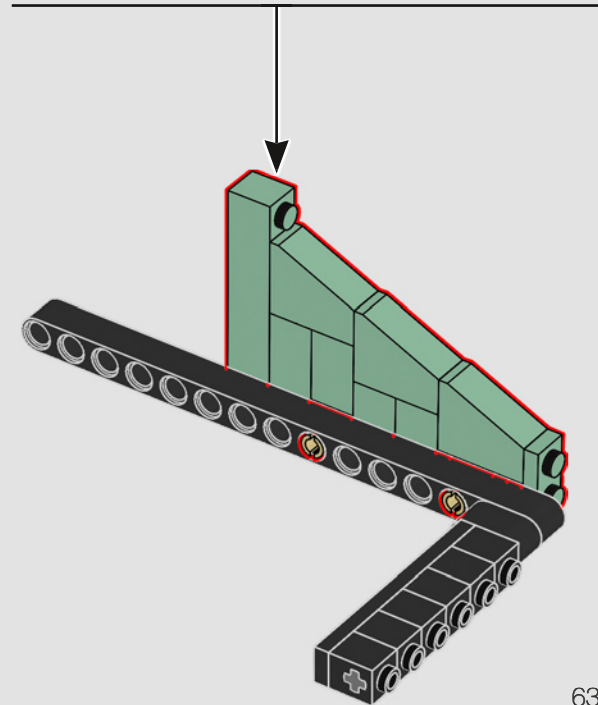
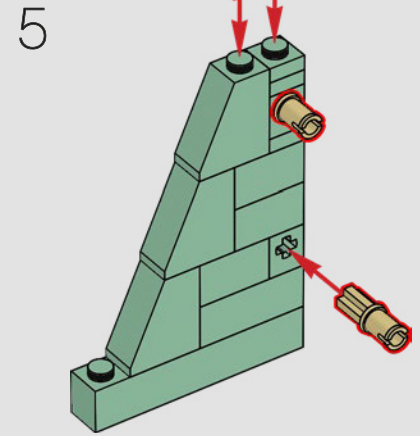
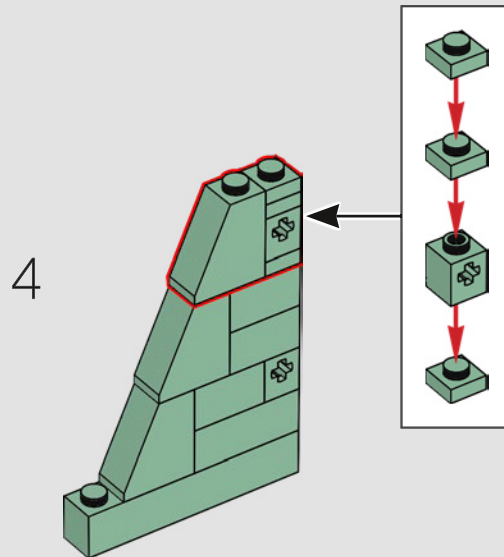
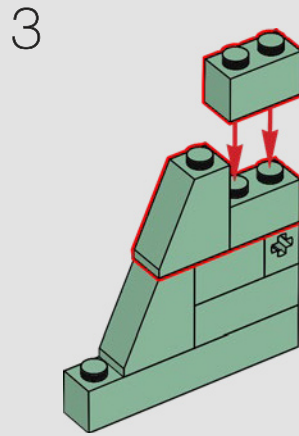
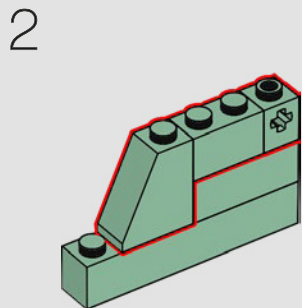
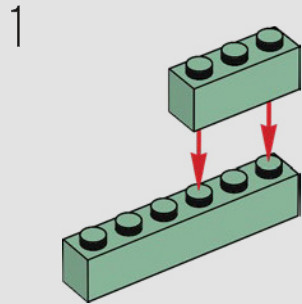

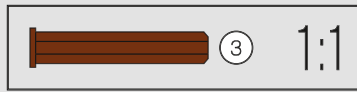
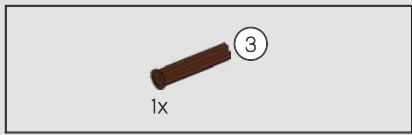

80

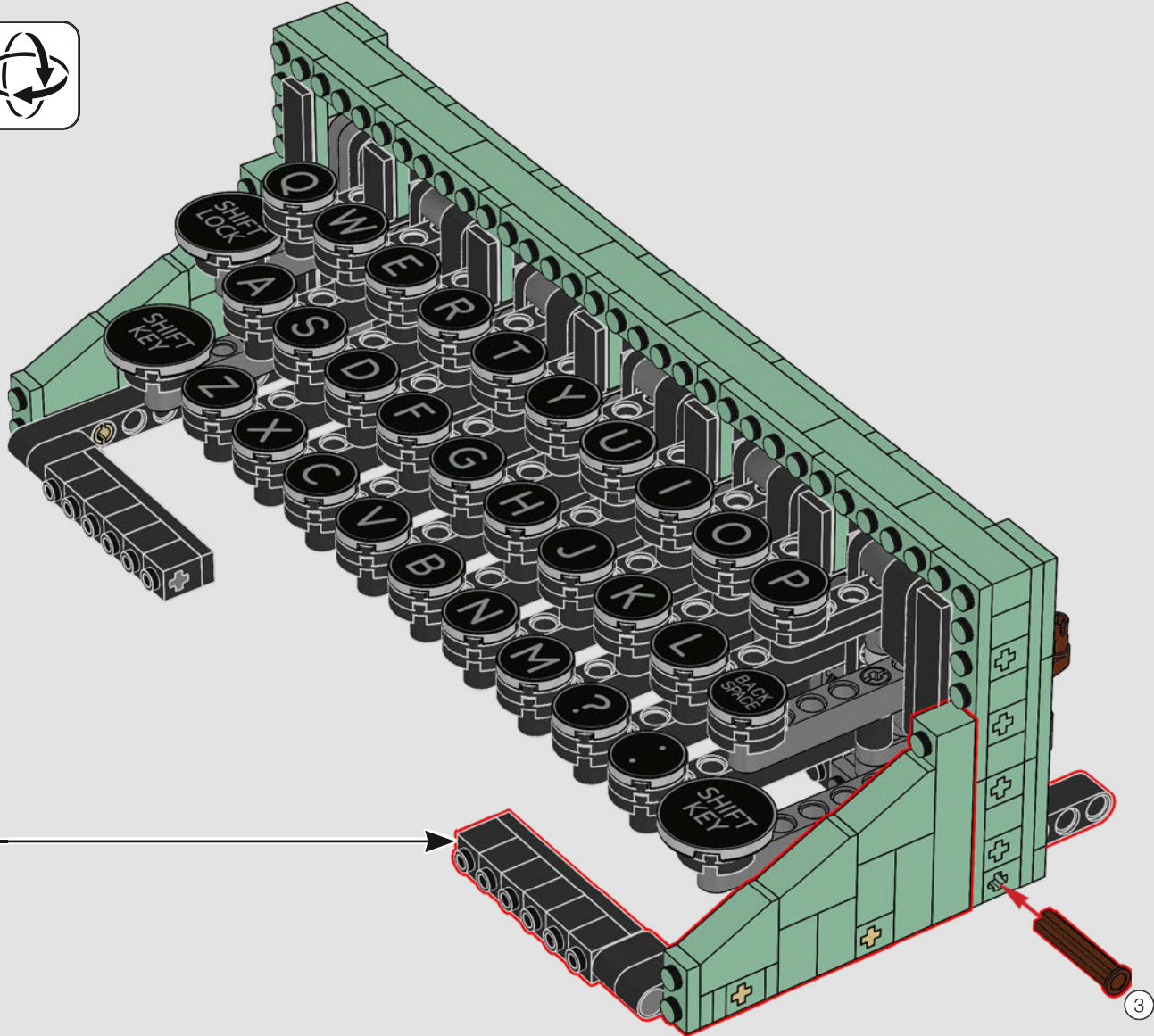

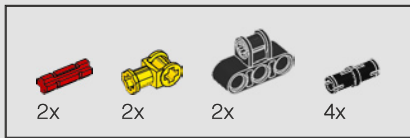

81

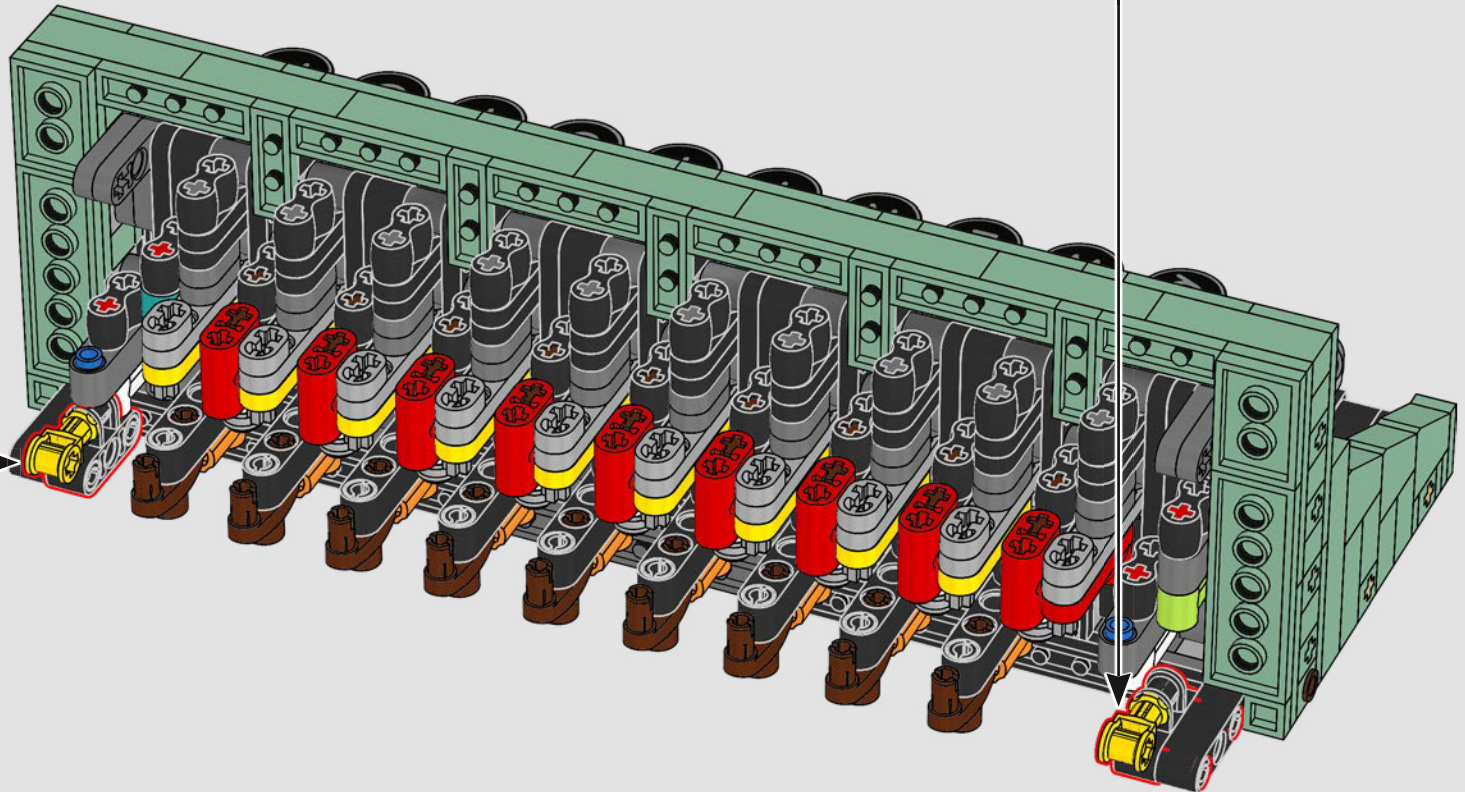
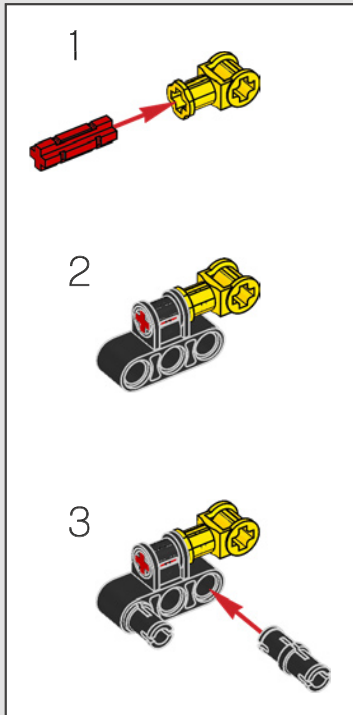
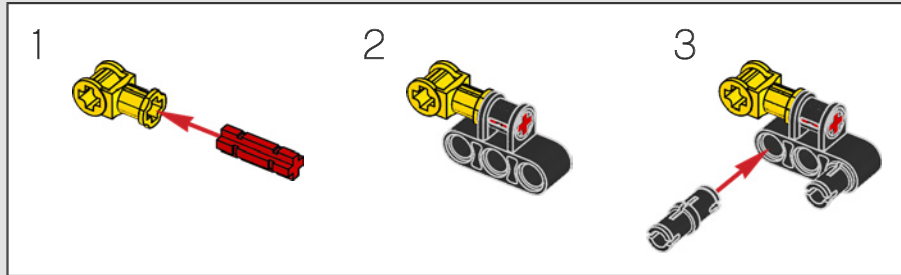

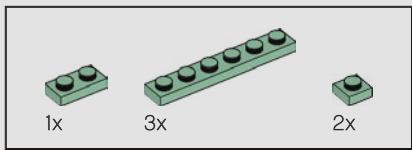

82

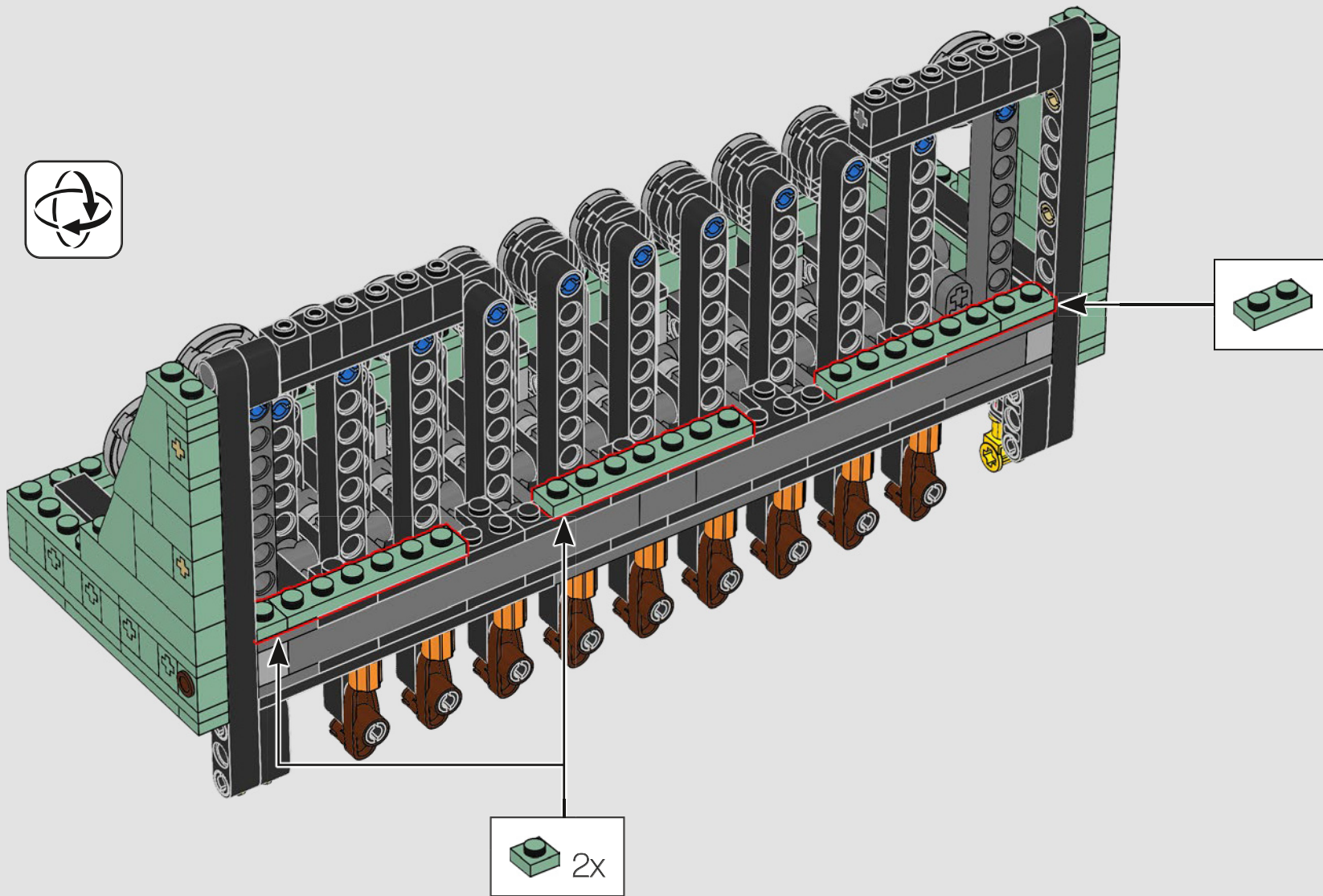

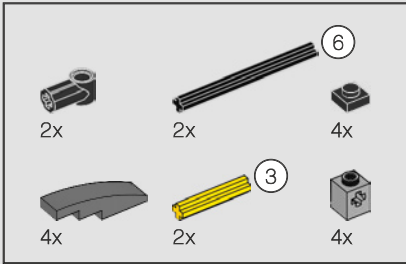
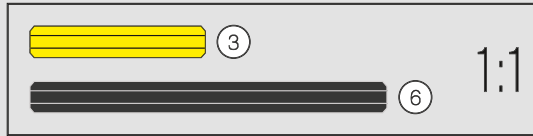
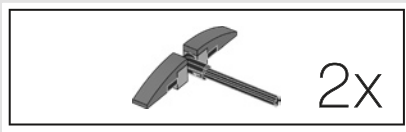

83

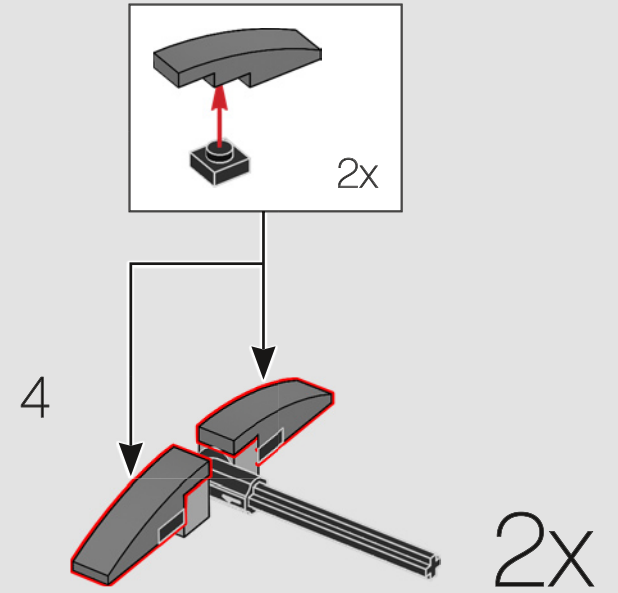
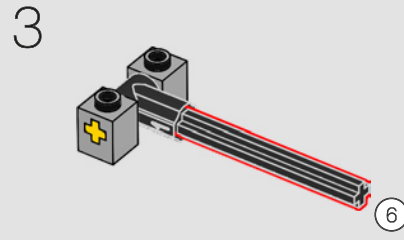
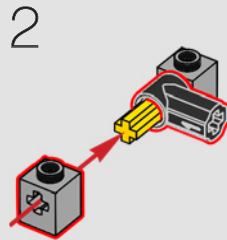
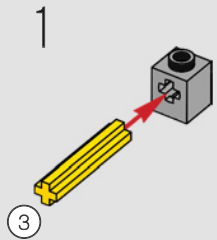

2x

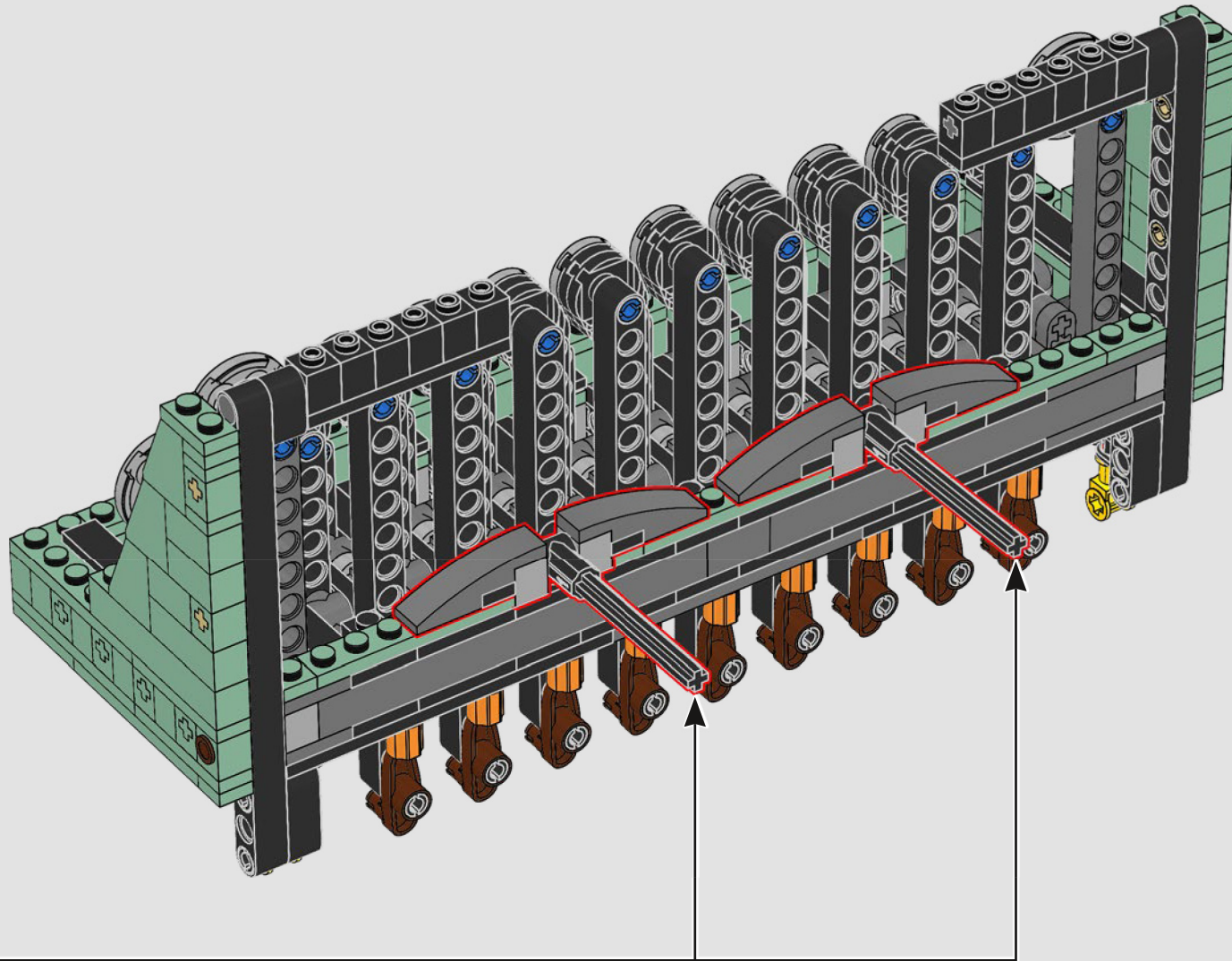

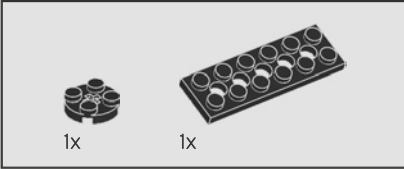
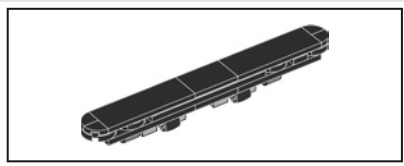

84

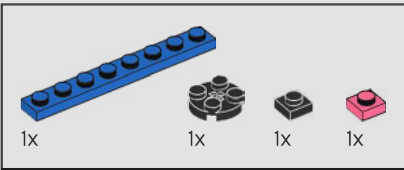
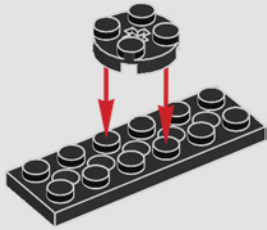

85

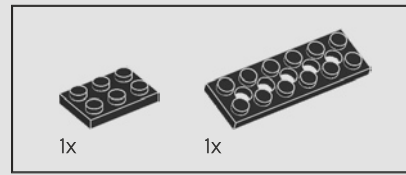
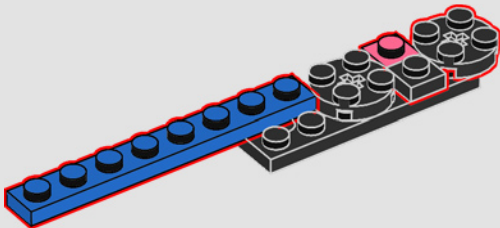

86

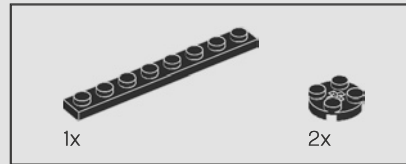
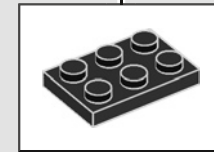
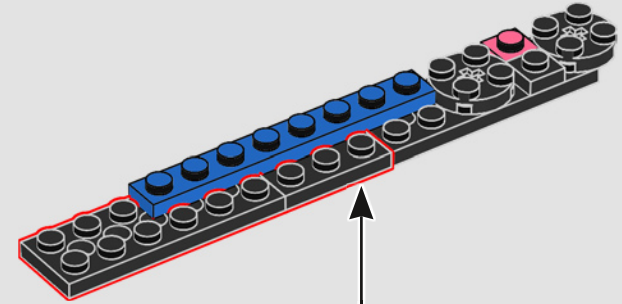

87

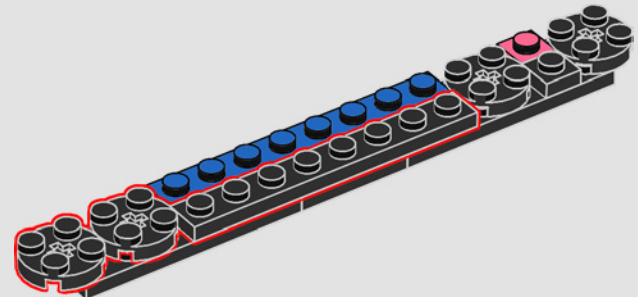

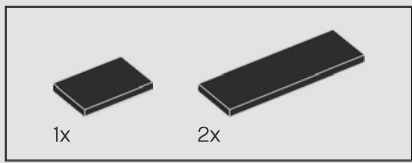

88

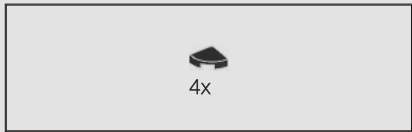
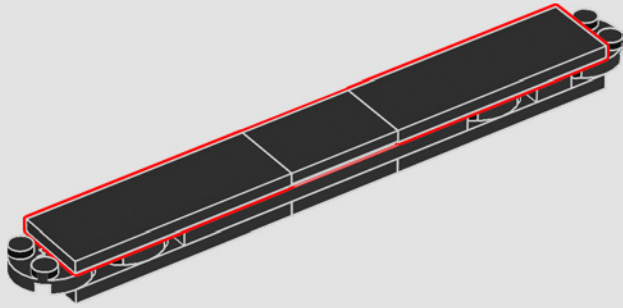

89

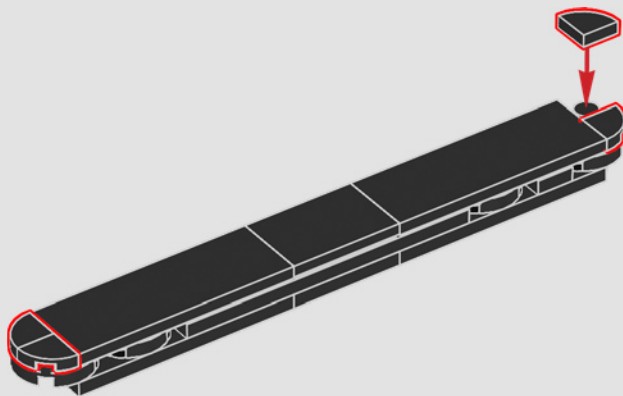

70

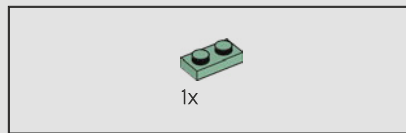

90

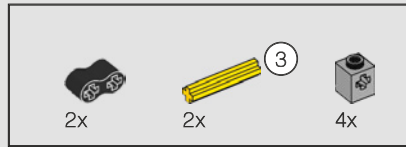
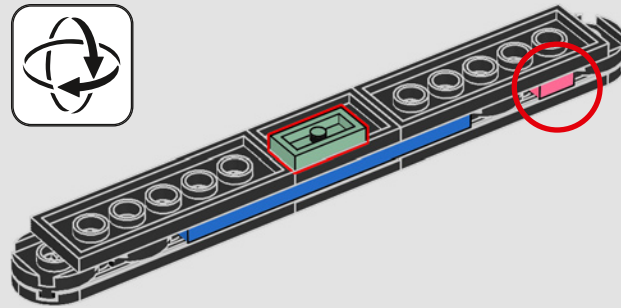

91

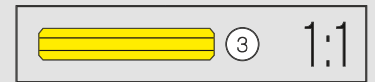
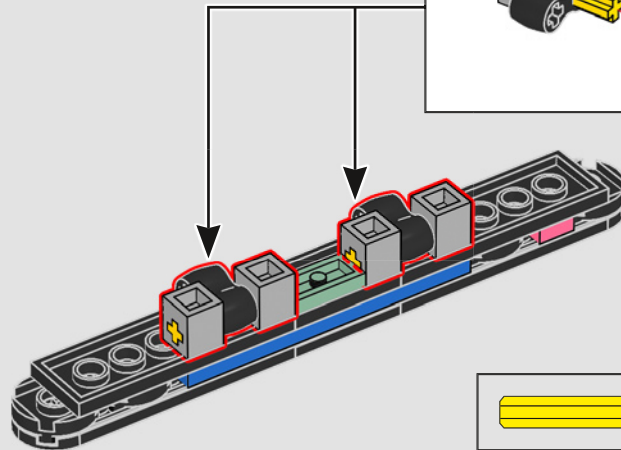
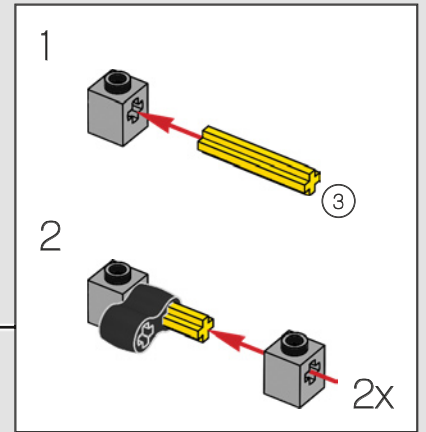

1:1



92

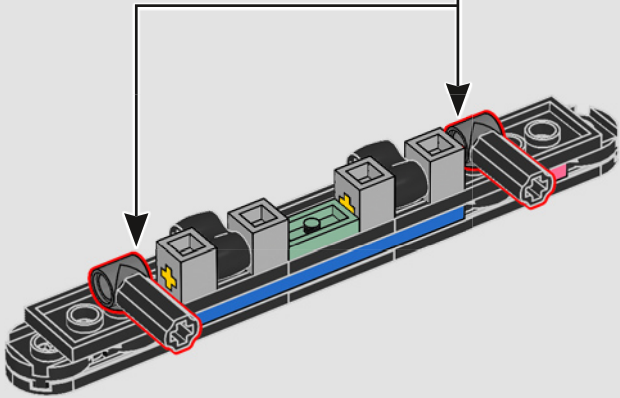
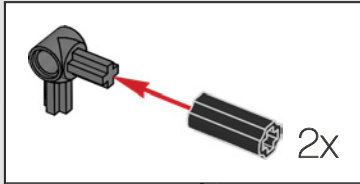

93

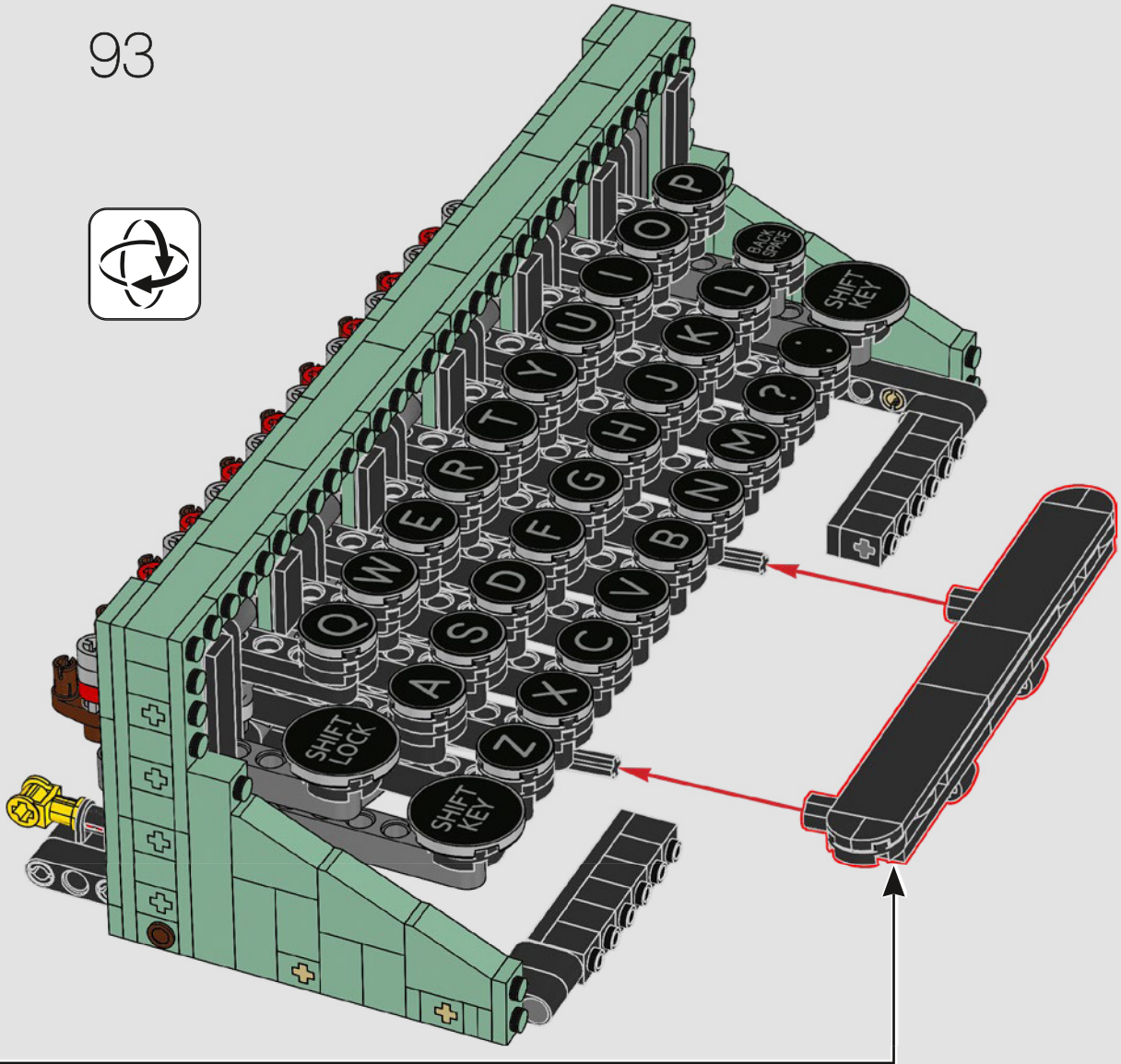

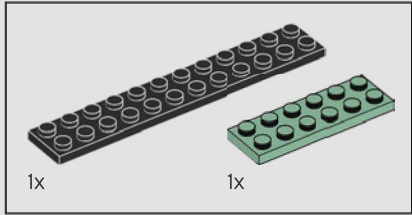
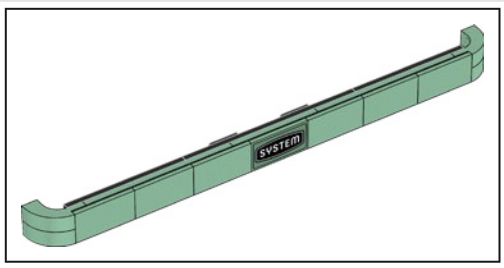

94

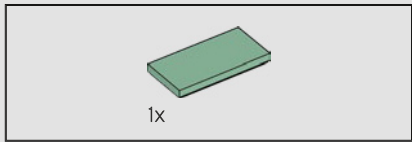
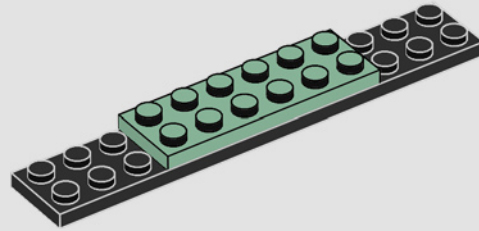

95

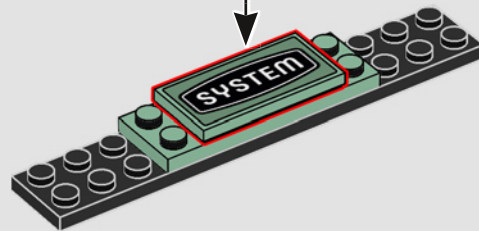
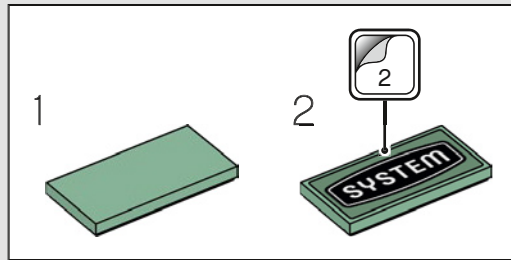

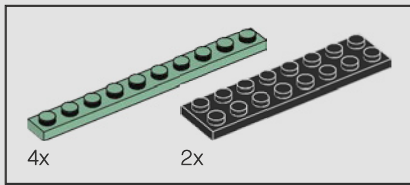

96

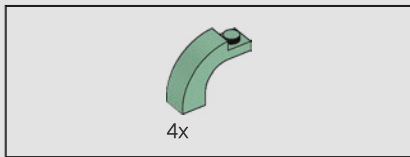
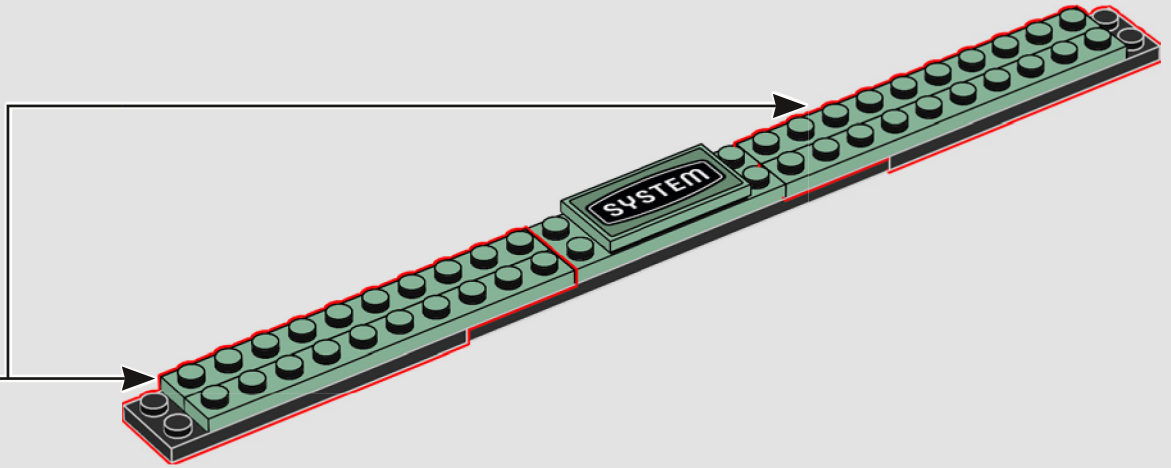
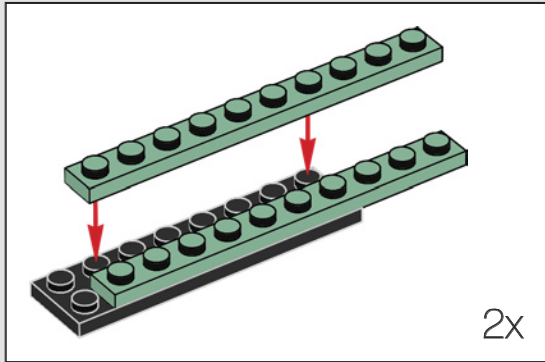

97

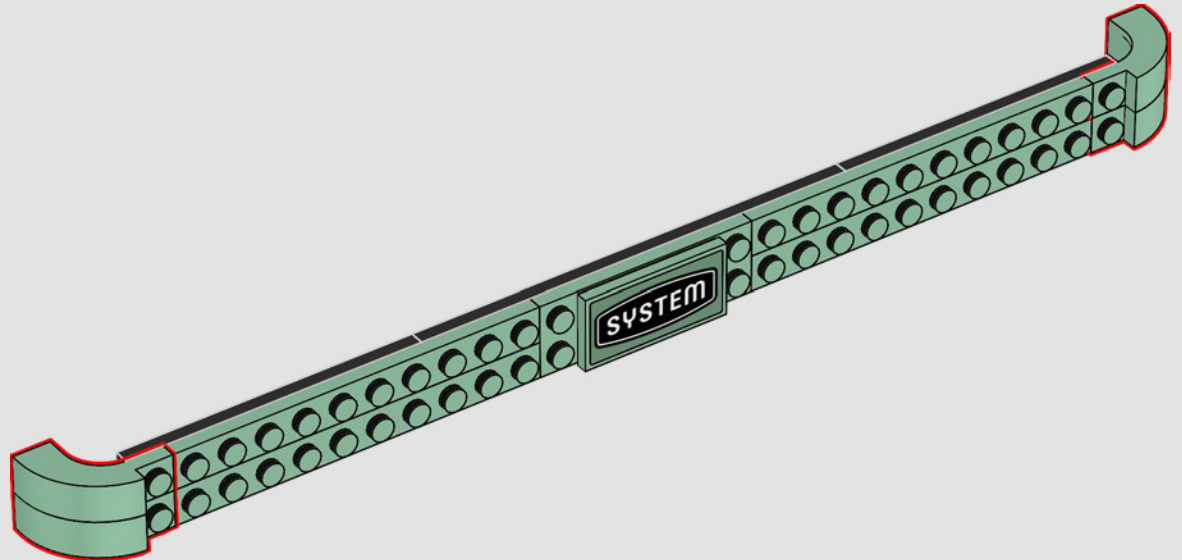

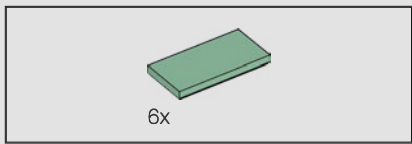

98

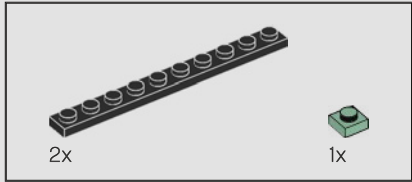
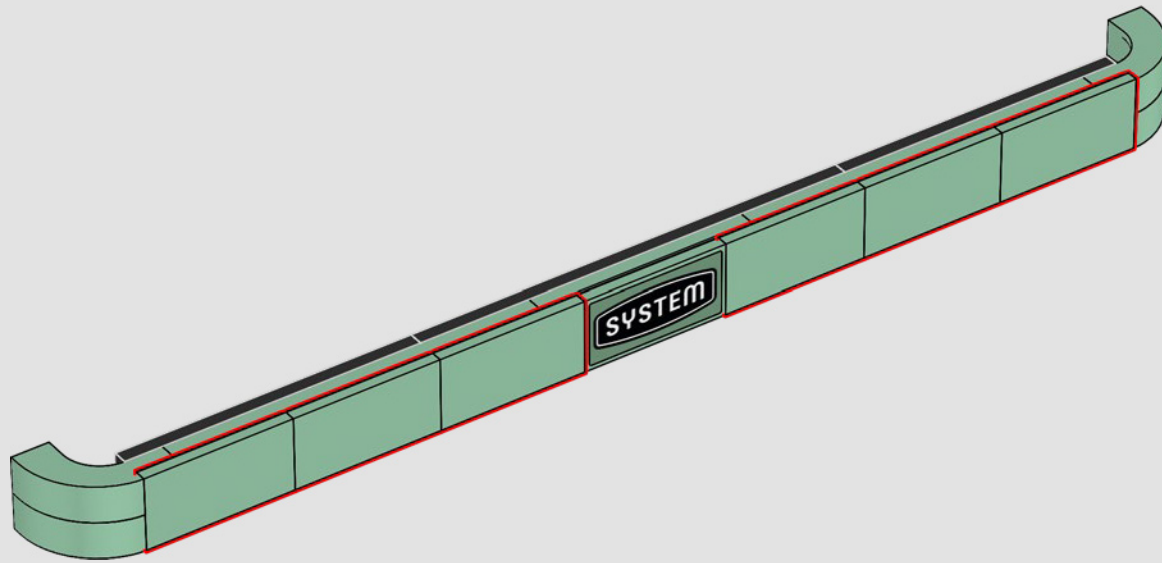

99

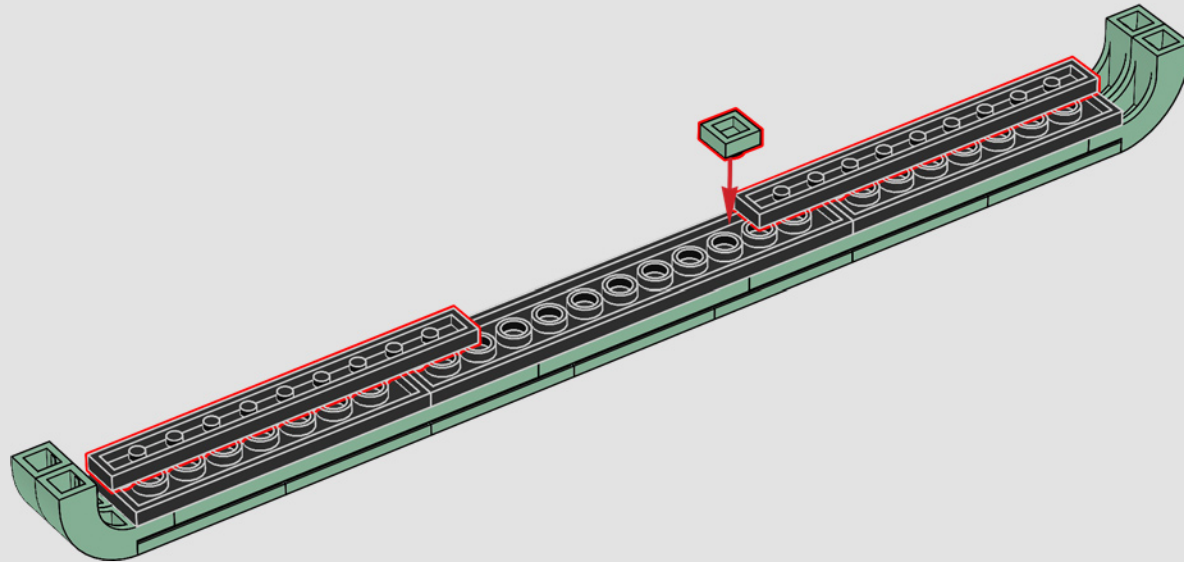

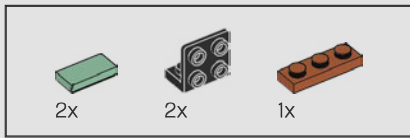

100

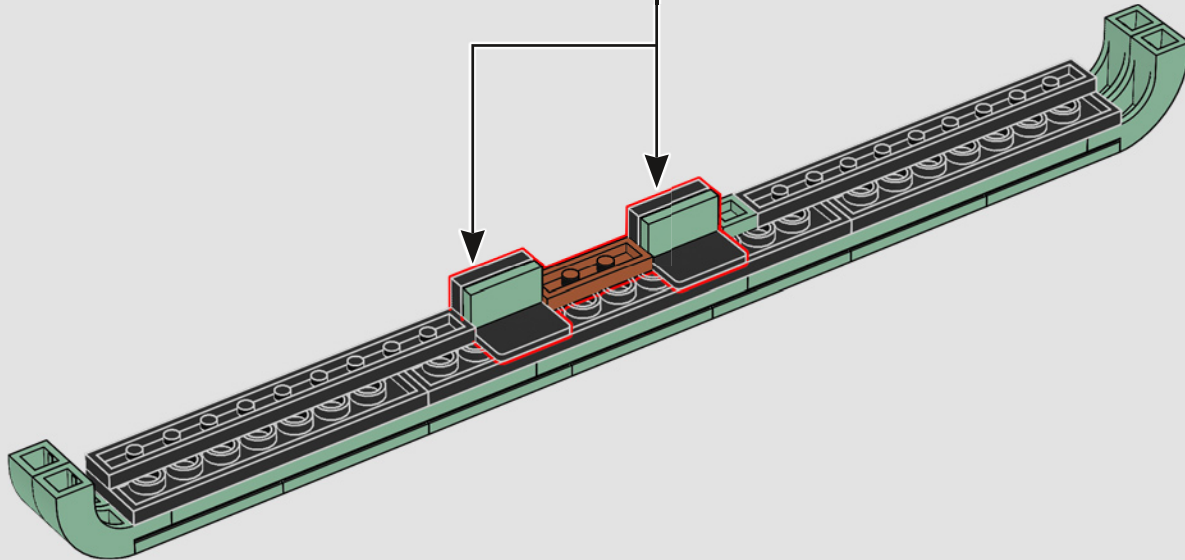
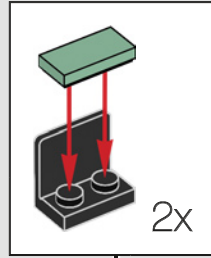

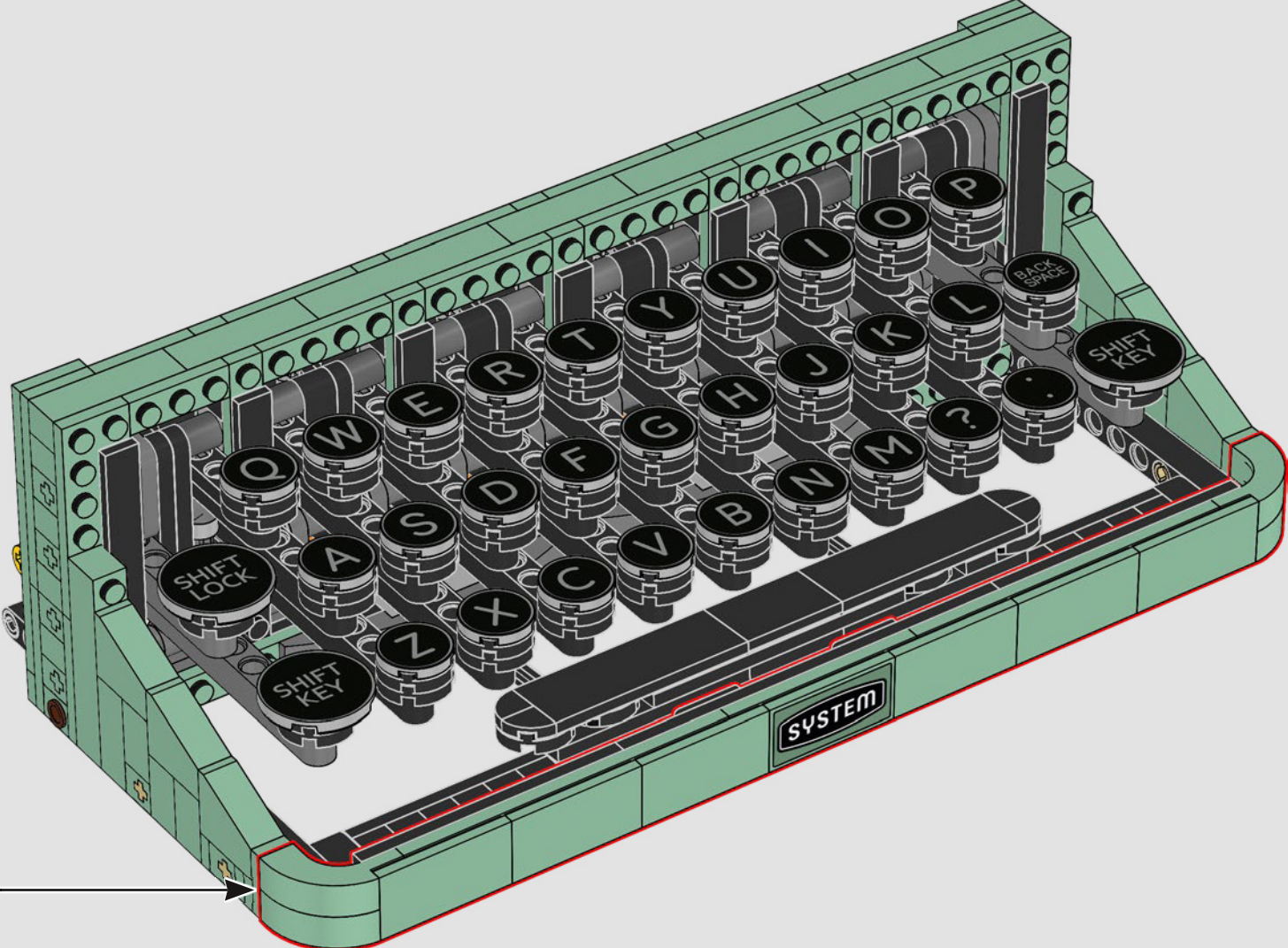

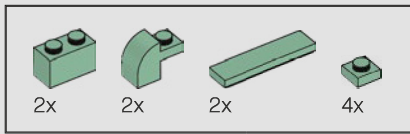

102

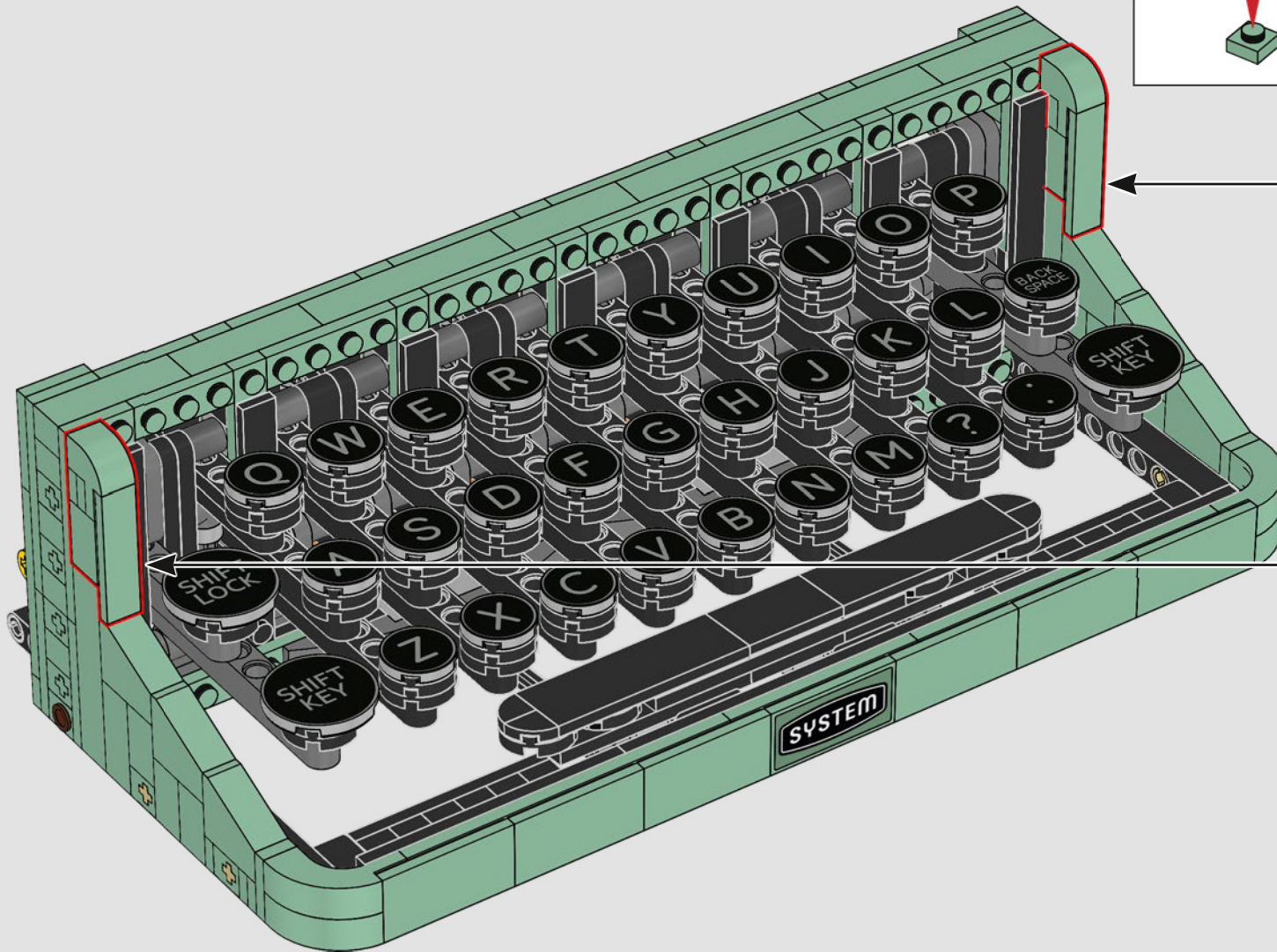
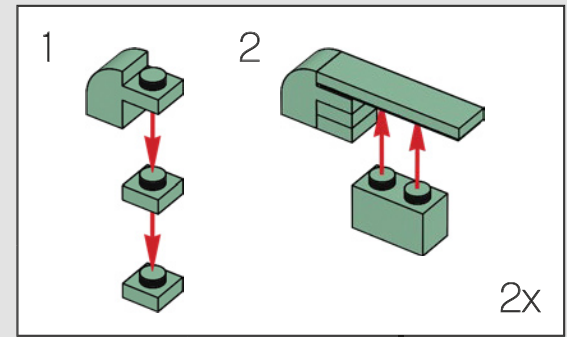

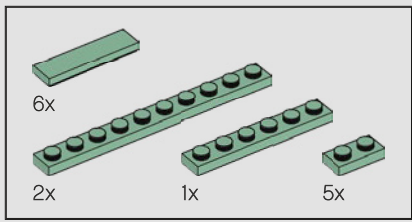

103

1

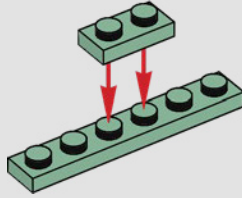

2

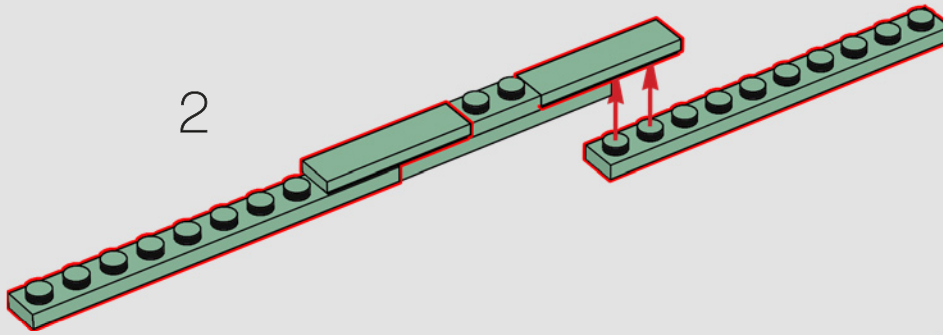

3

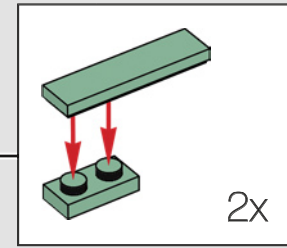
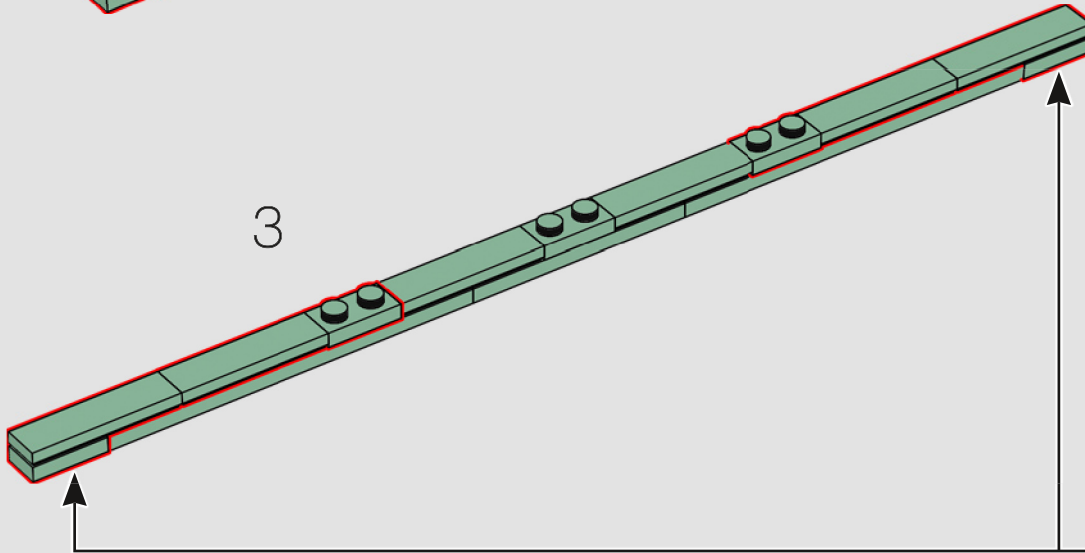

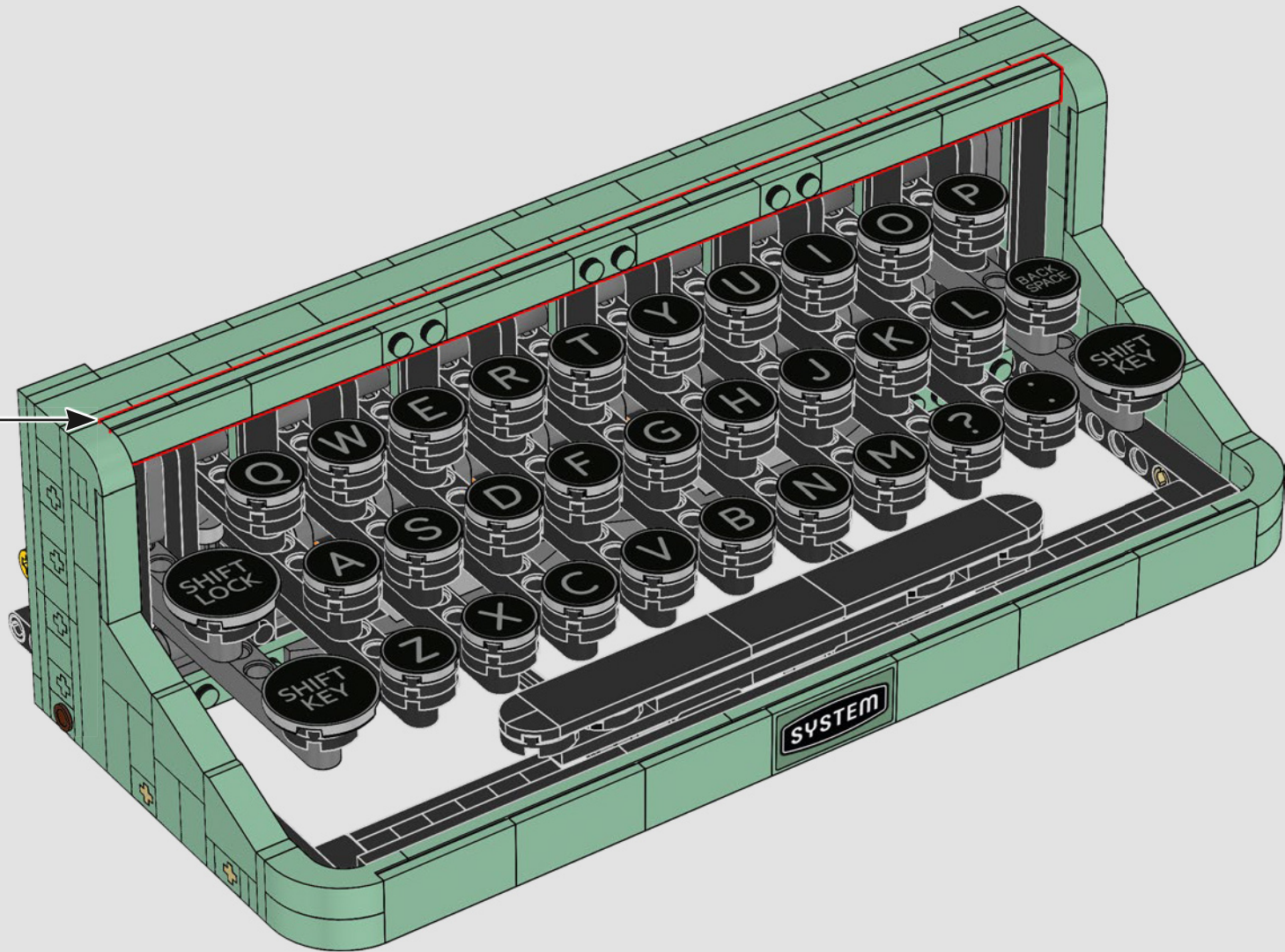

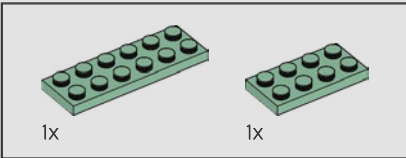
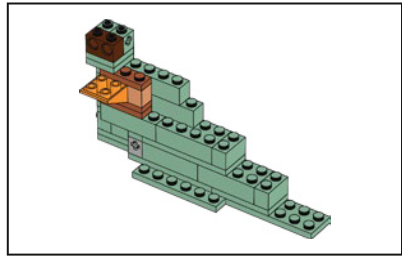
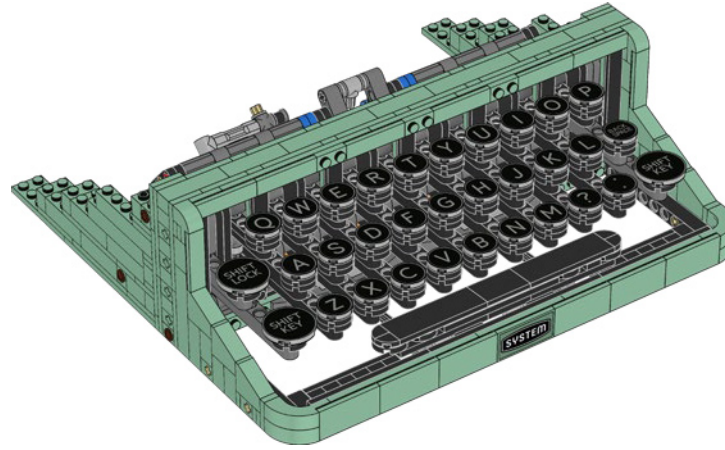

104

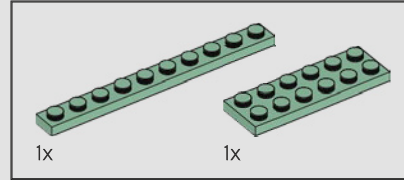
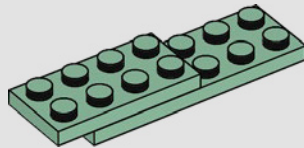

105

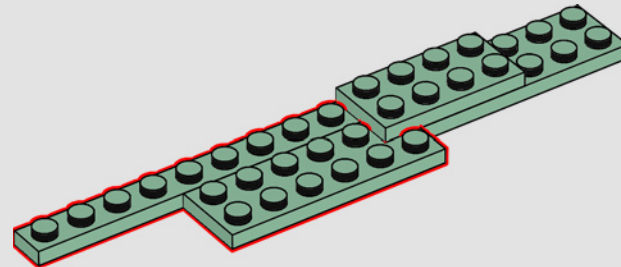

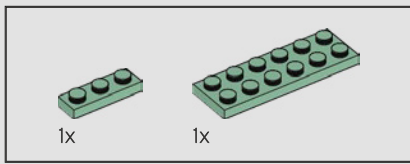

106

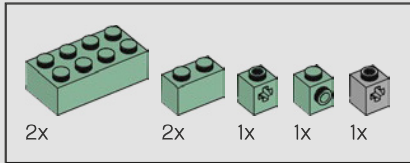
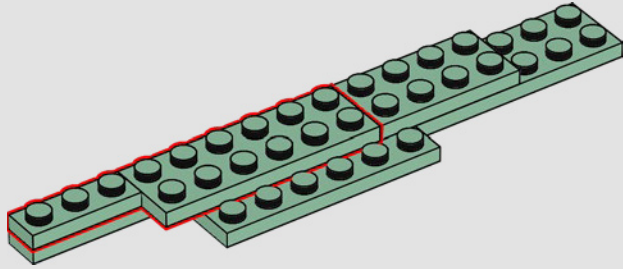

107

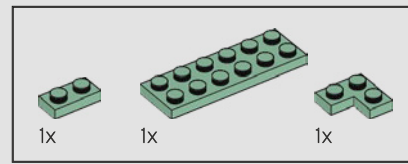
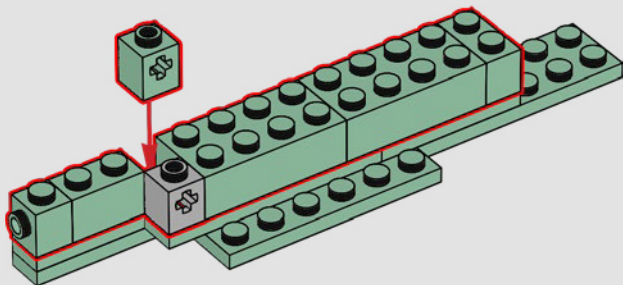

108

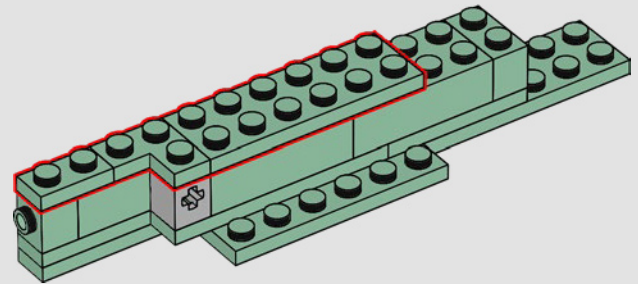

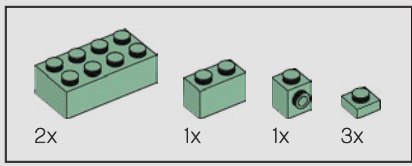

109

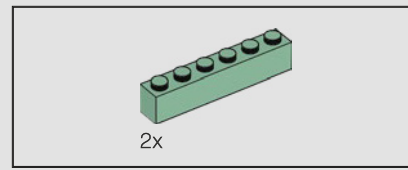
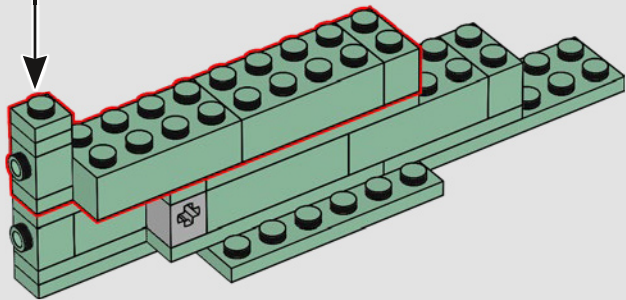
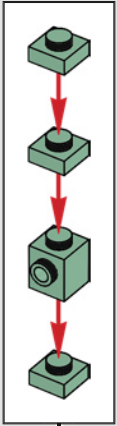

110

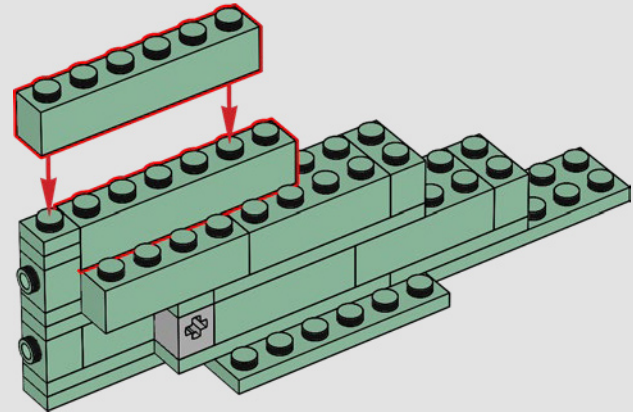

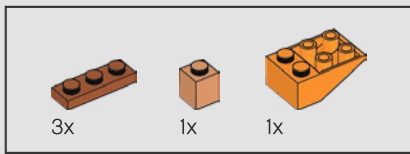

111

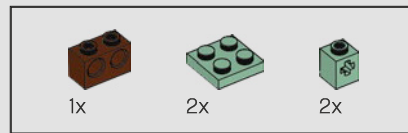
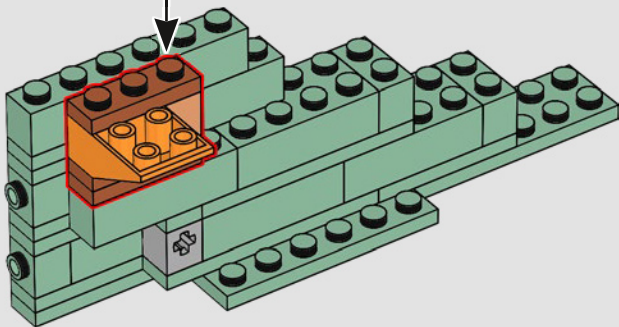
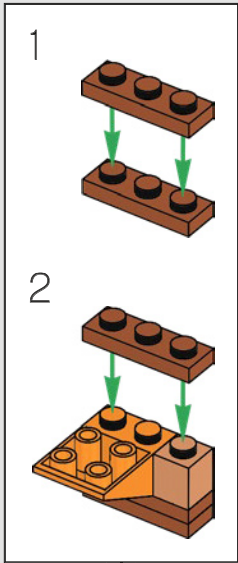

112

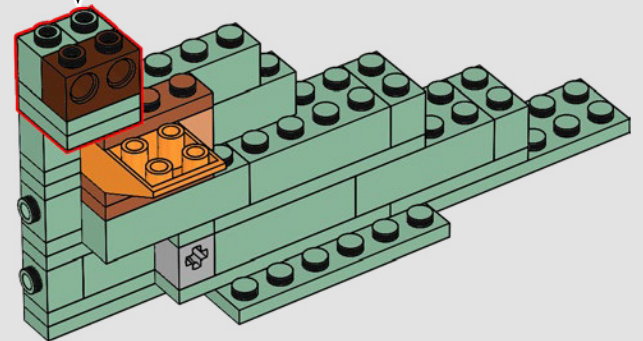
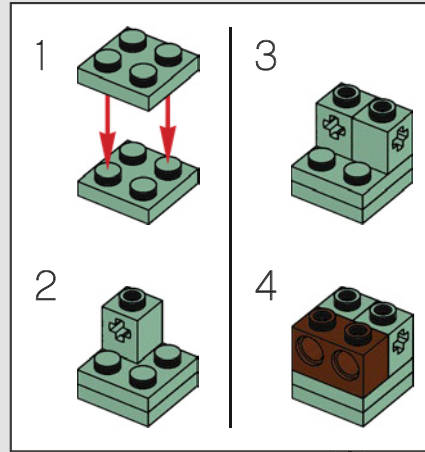

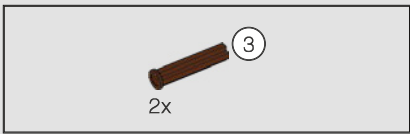

113

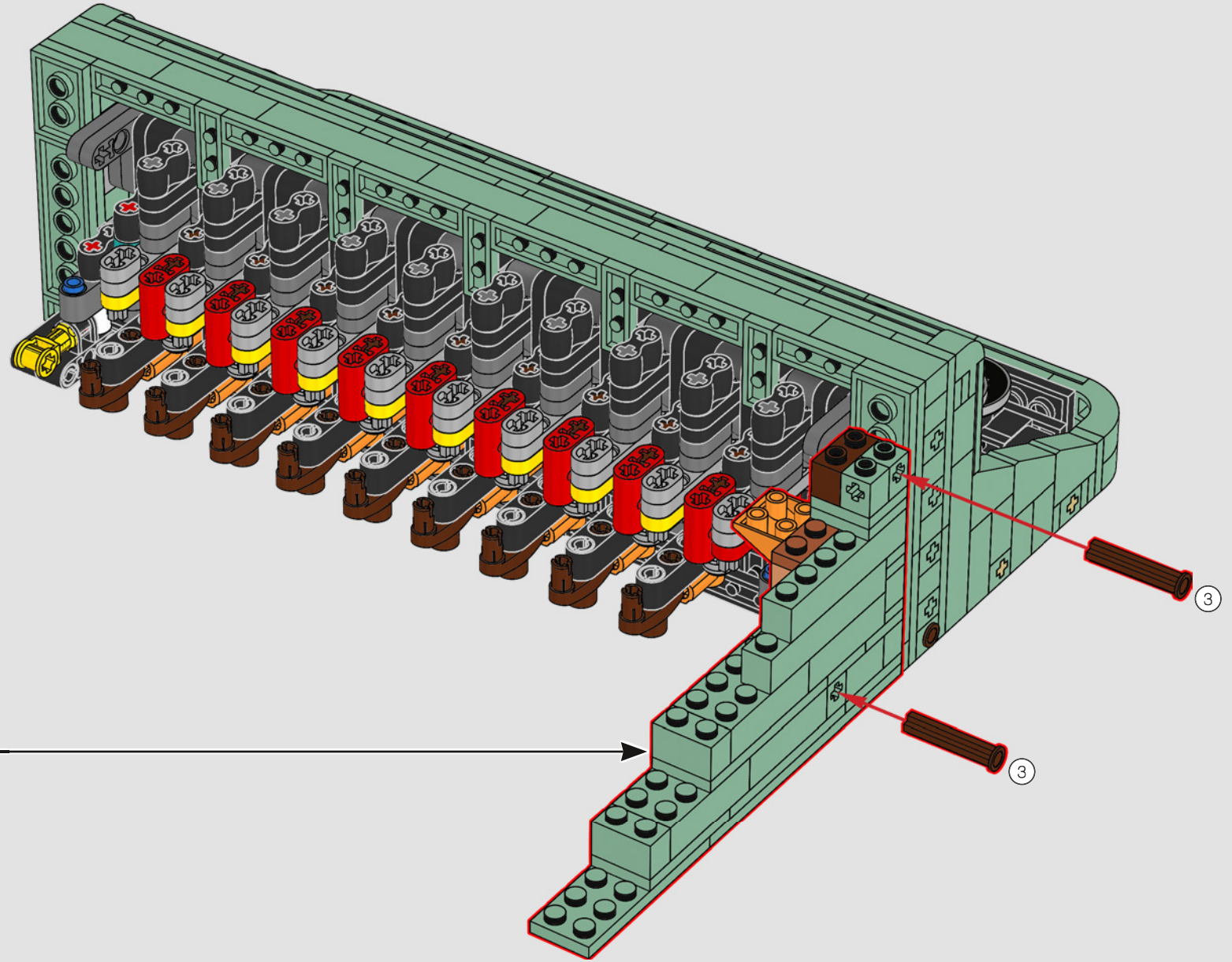

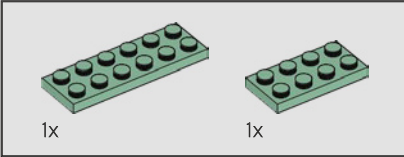
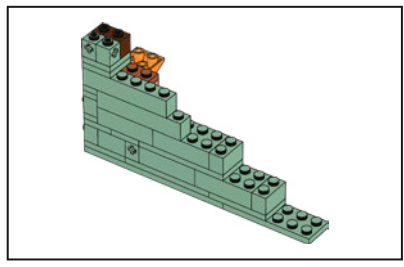

114

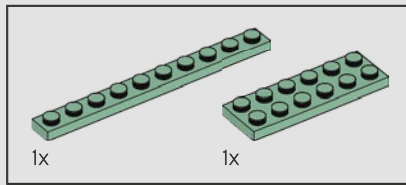
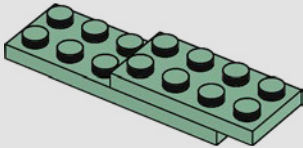

115

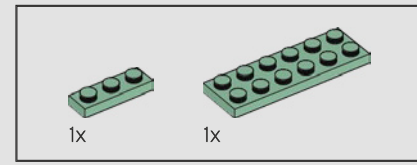
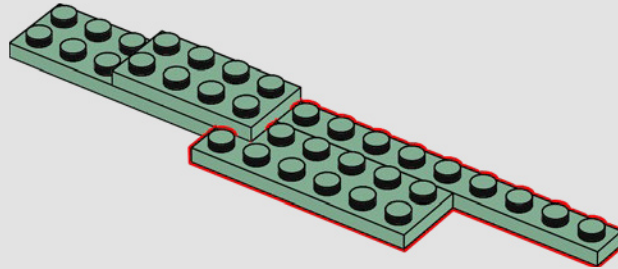

116

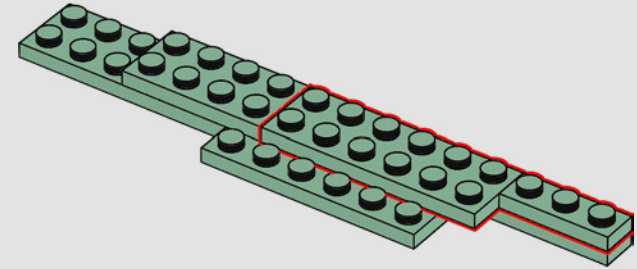

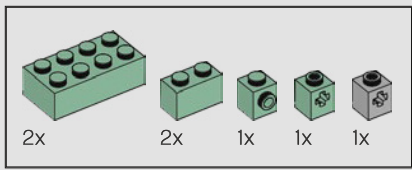

117

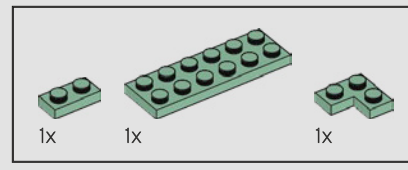
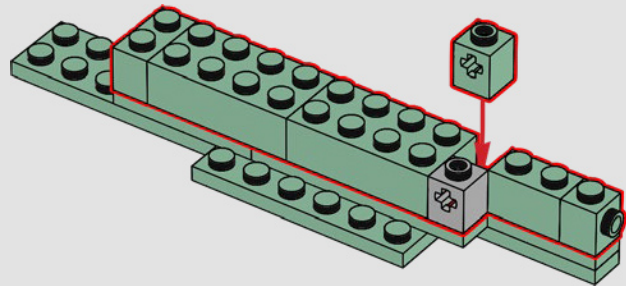

118

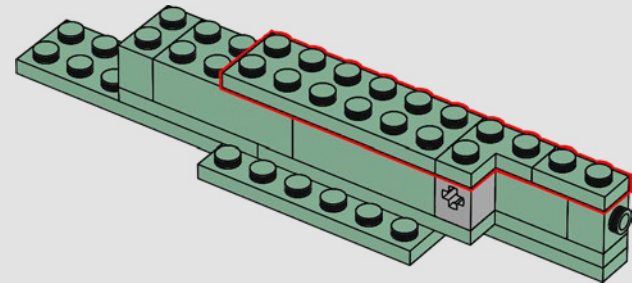

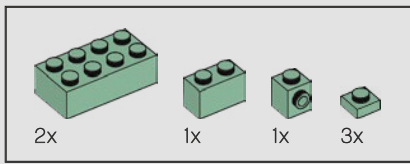

119

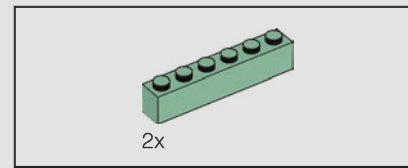
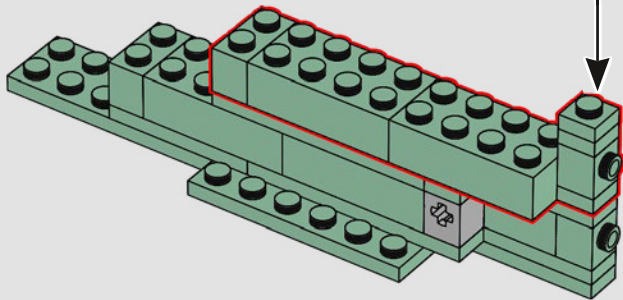
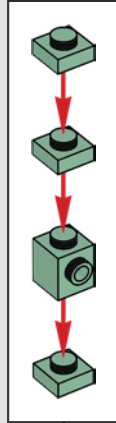

120

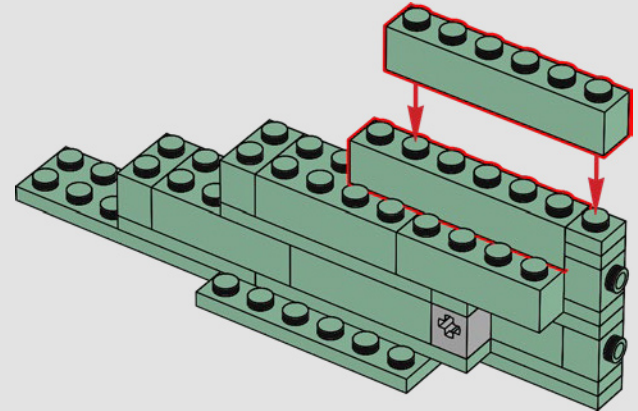

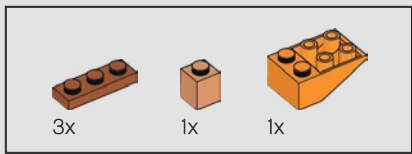

121

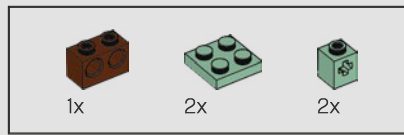
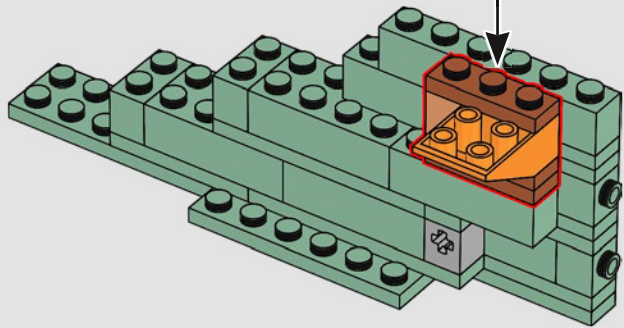
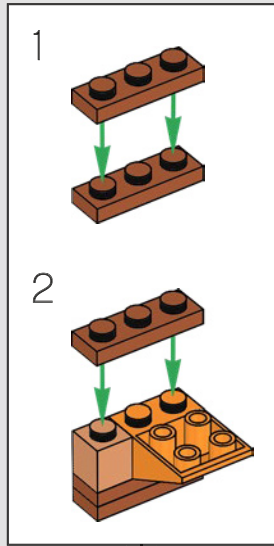

122

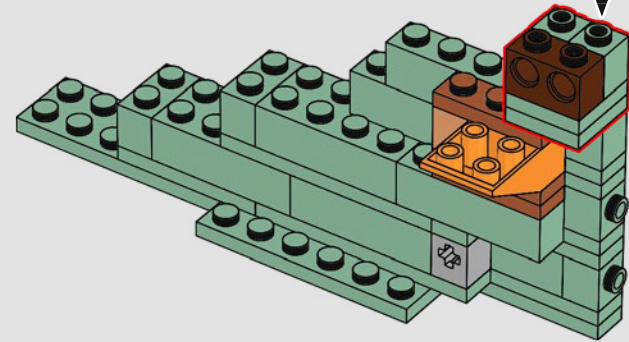
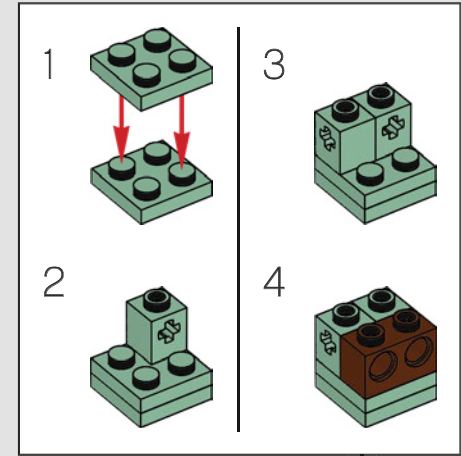

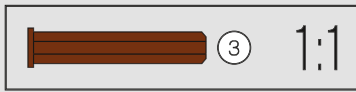
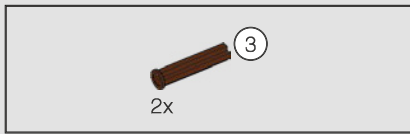

123

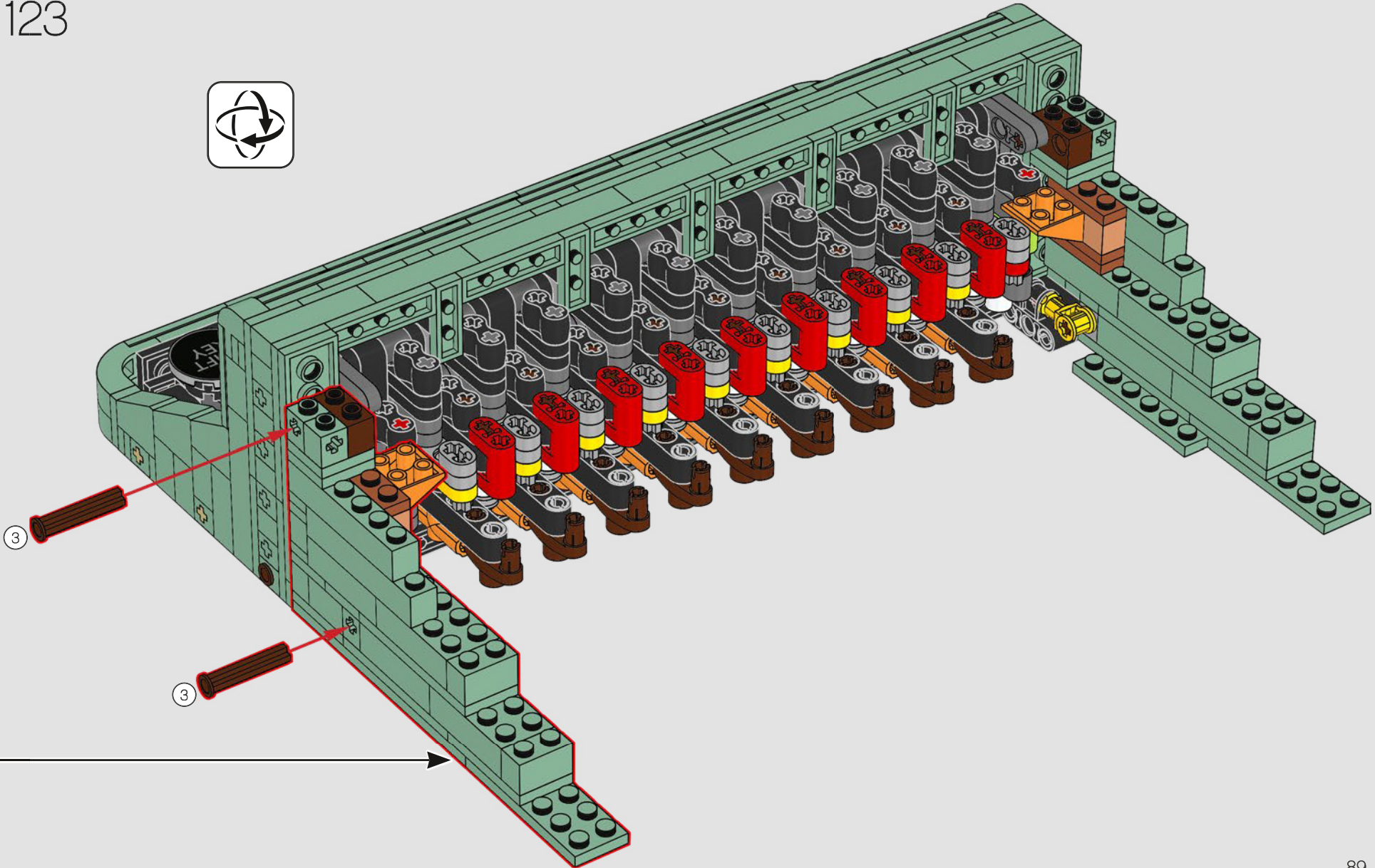

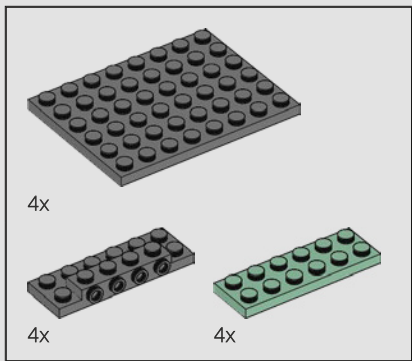

124

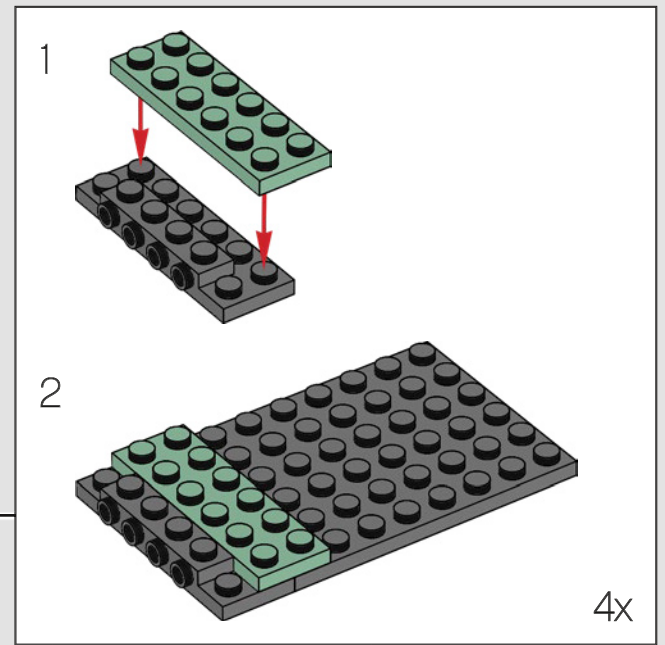
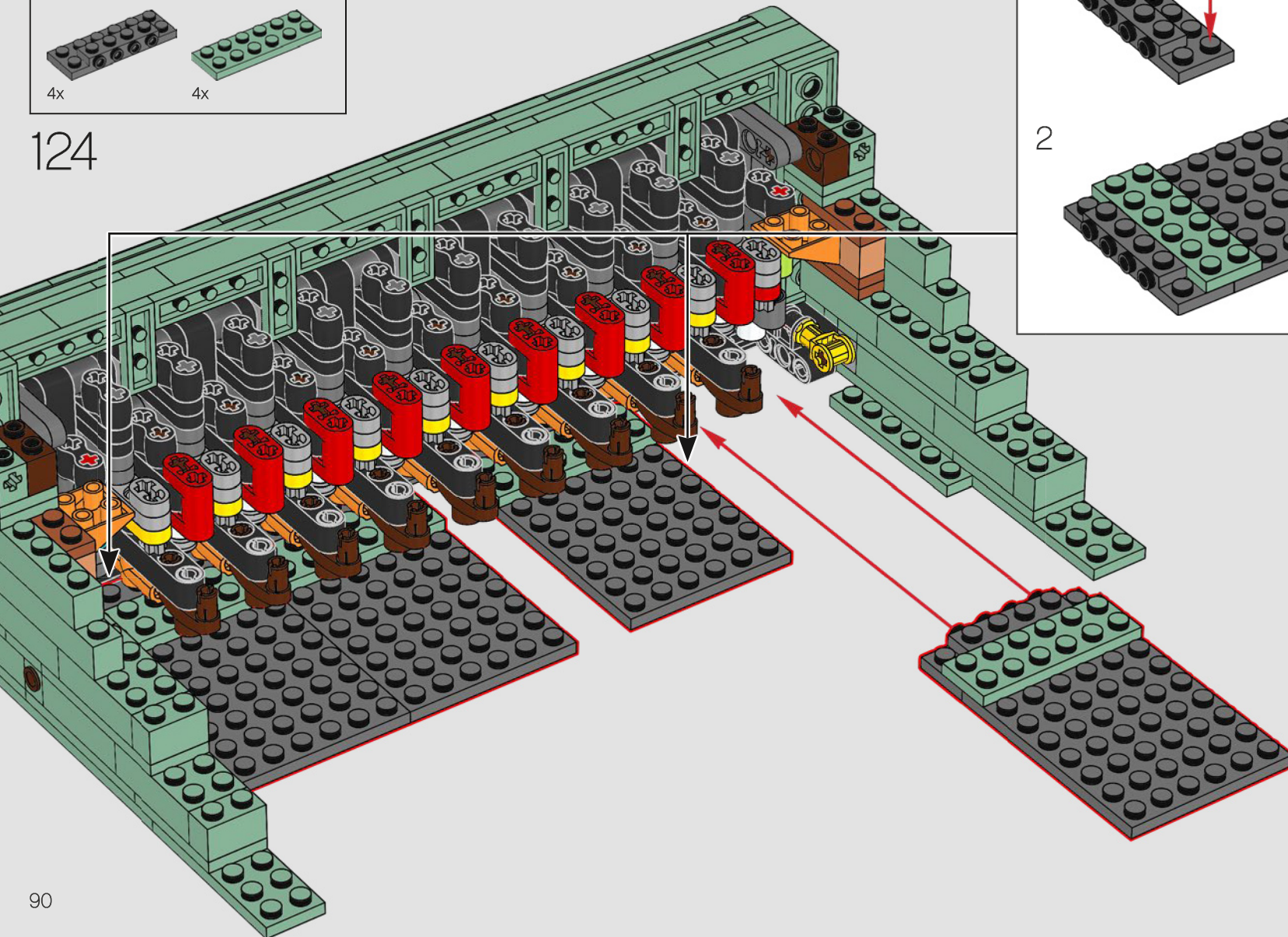

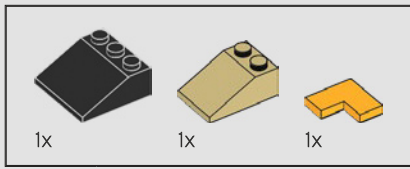

125

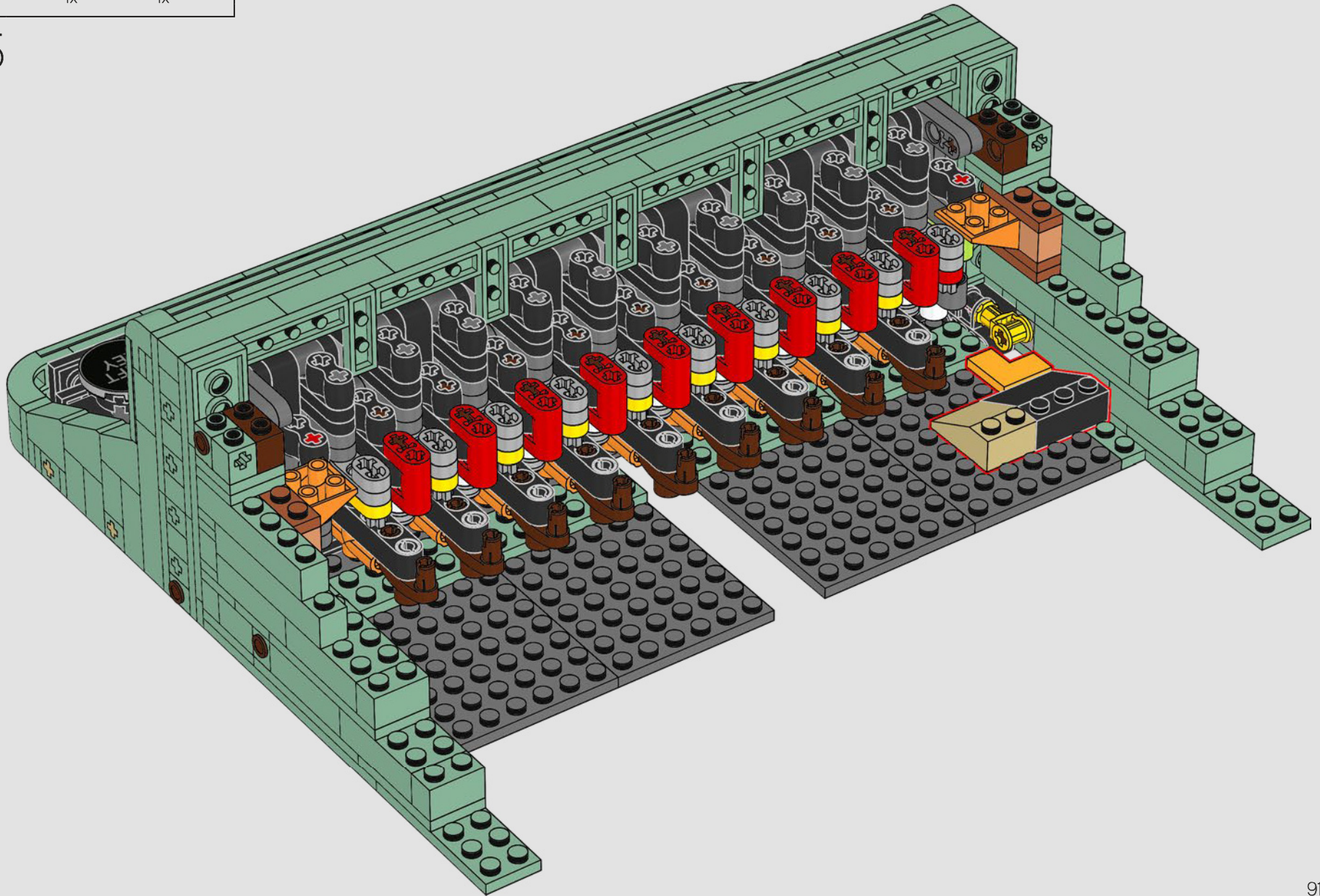

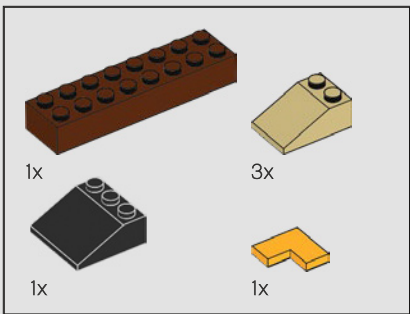

126

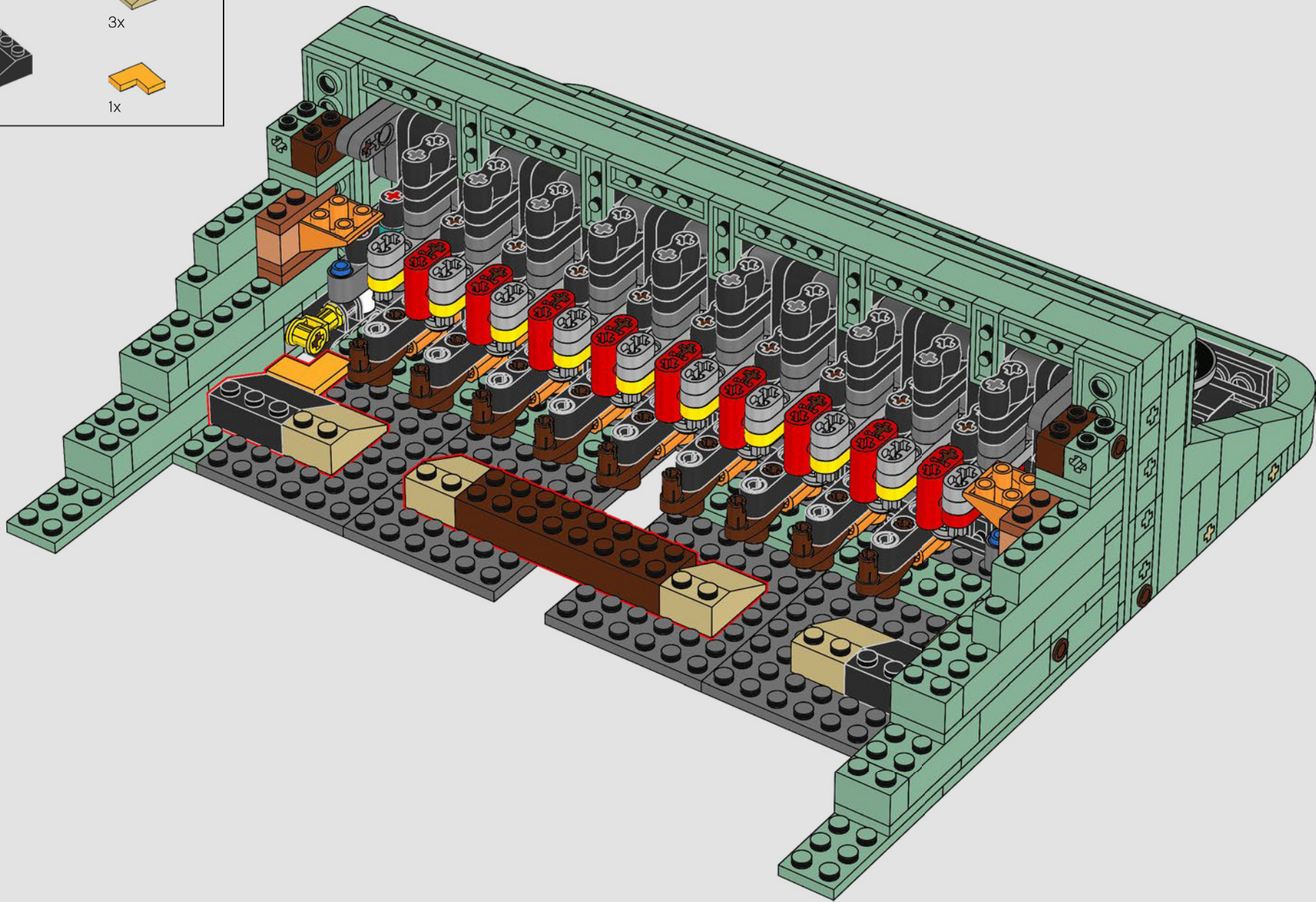

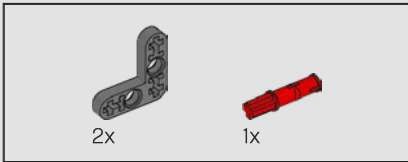
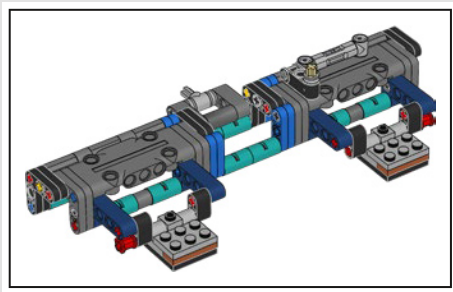

127

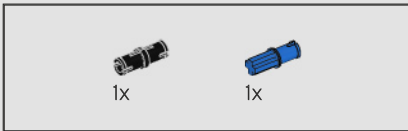
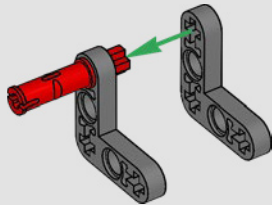

128

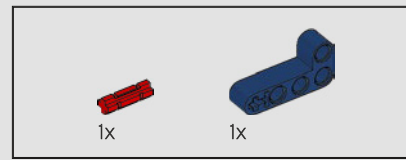
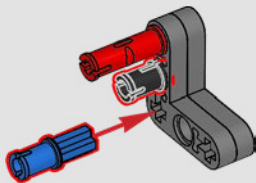

129

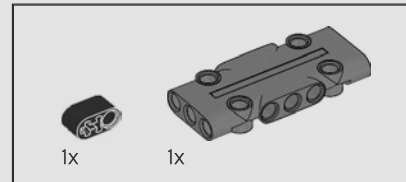
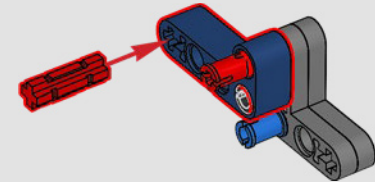

130

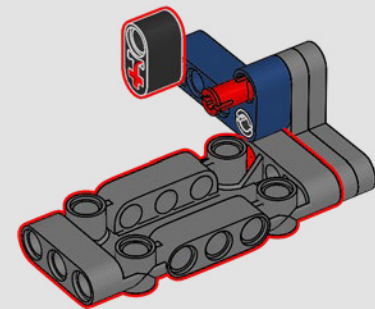

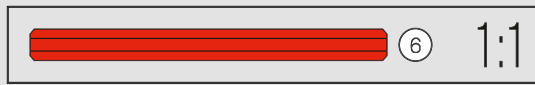
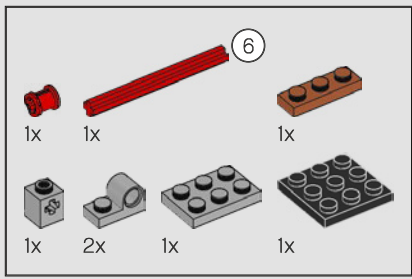

131

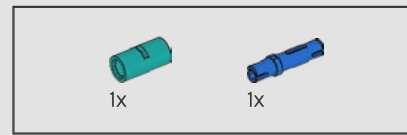
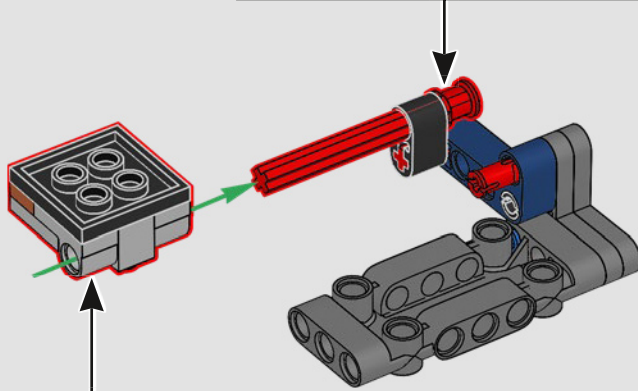
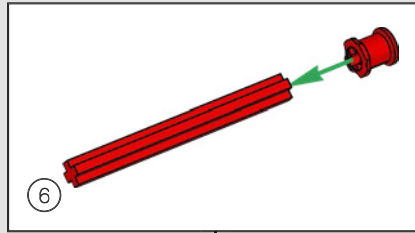
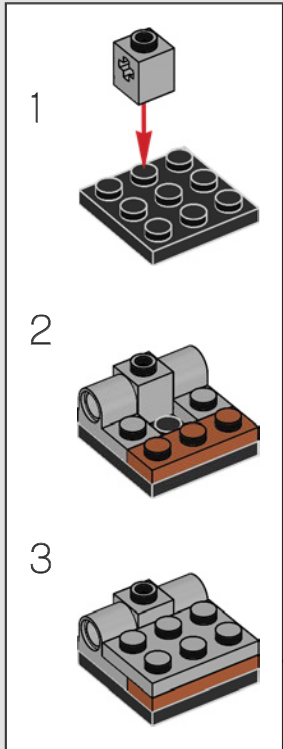

132

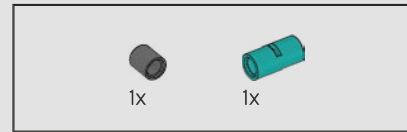
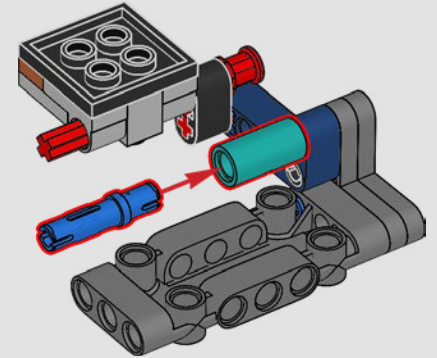

133

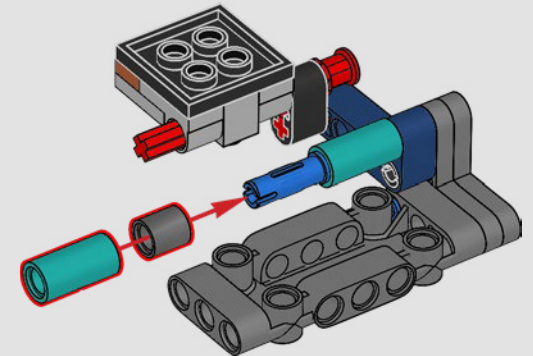

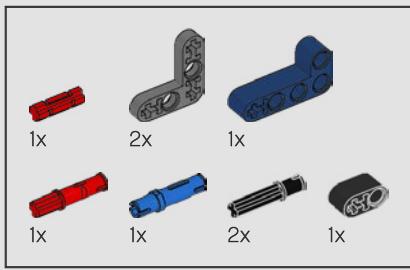

134

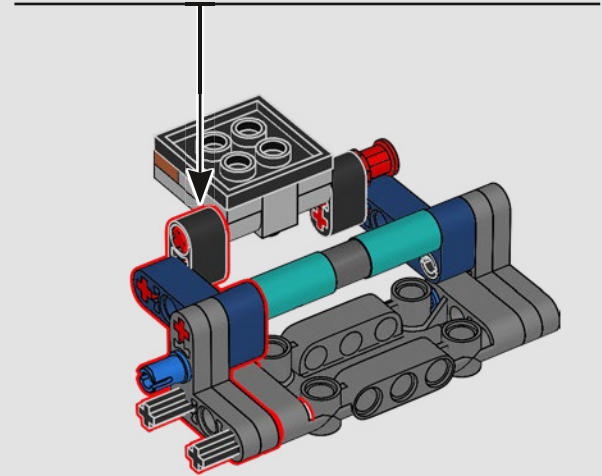
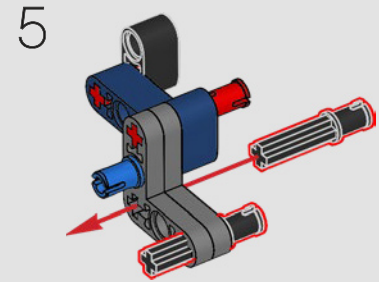
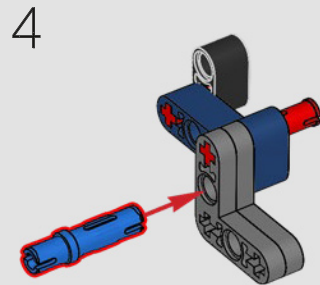
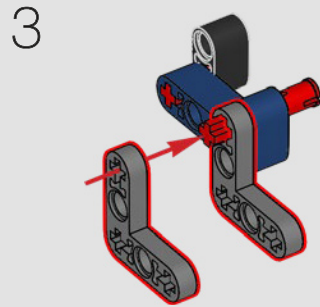
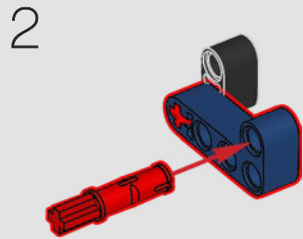
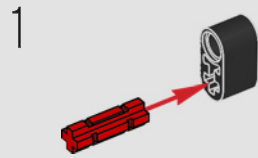

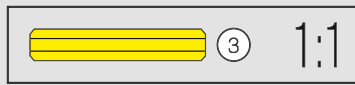
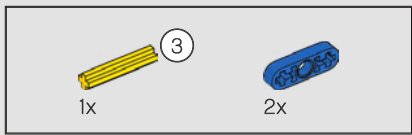

135

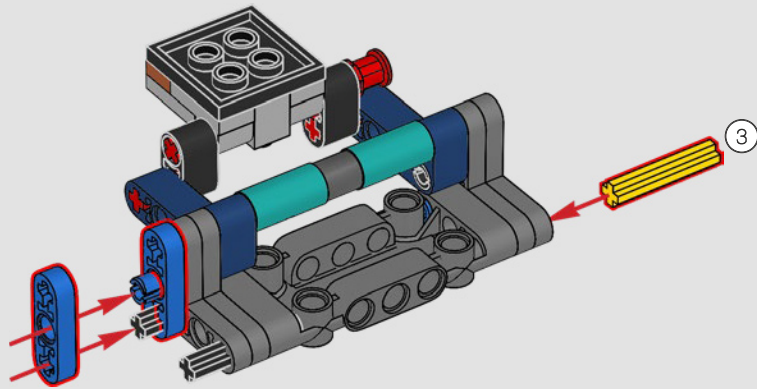

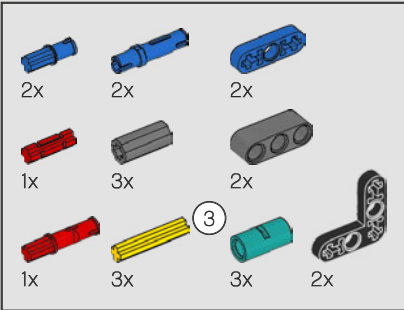
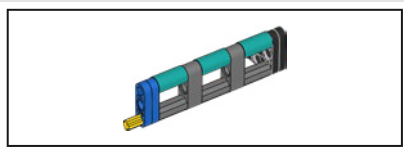

136

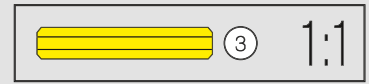
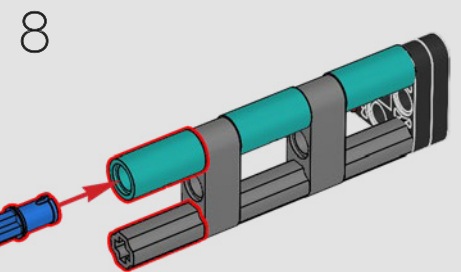
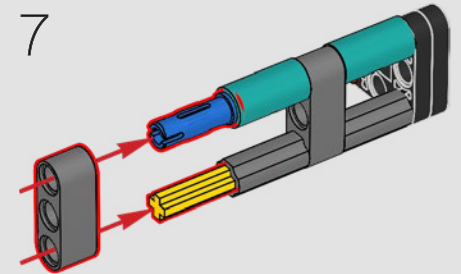
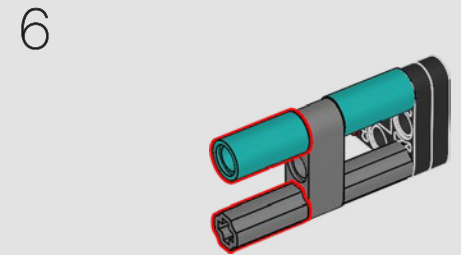
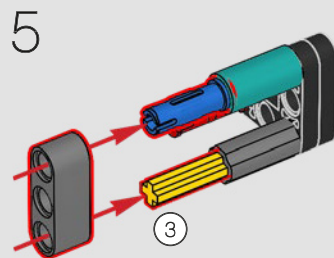
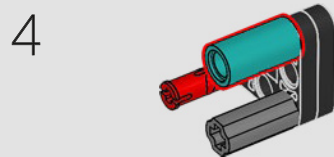
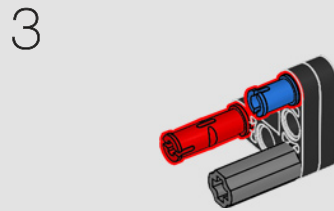
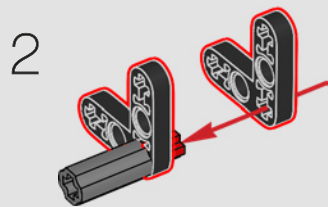
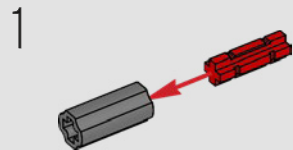

9

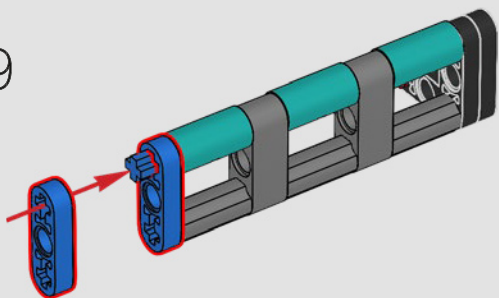

10

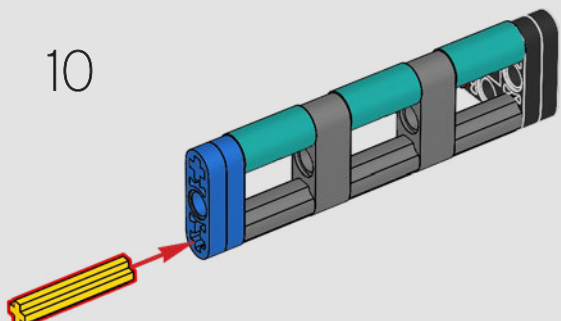

3

98

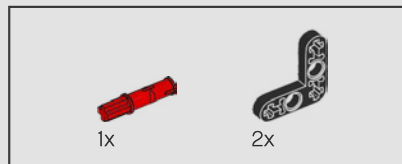
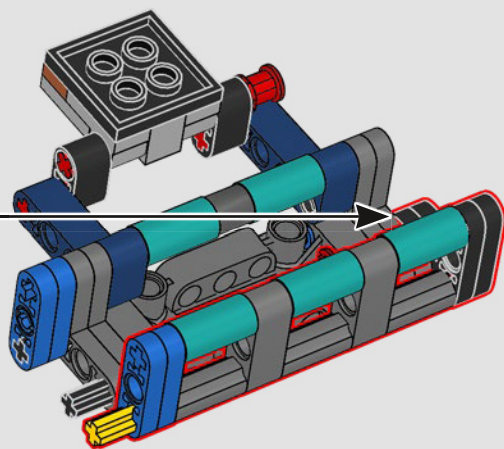

137

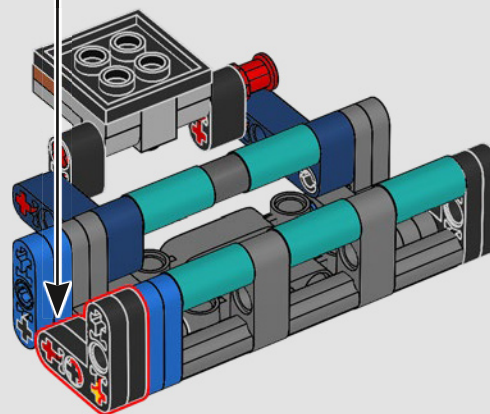
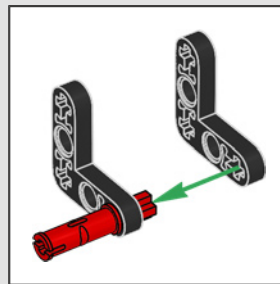

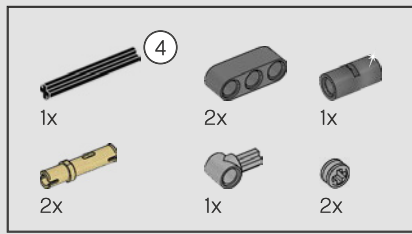

138

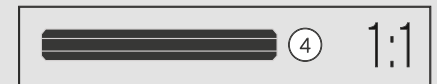
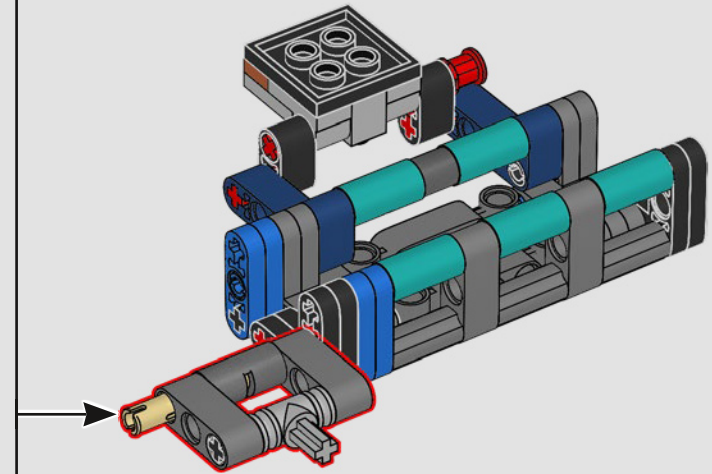
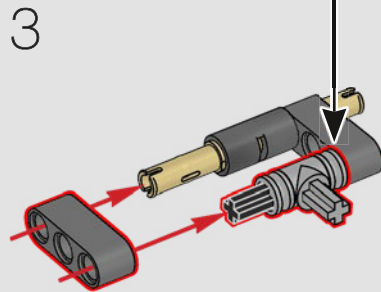
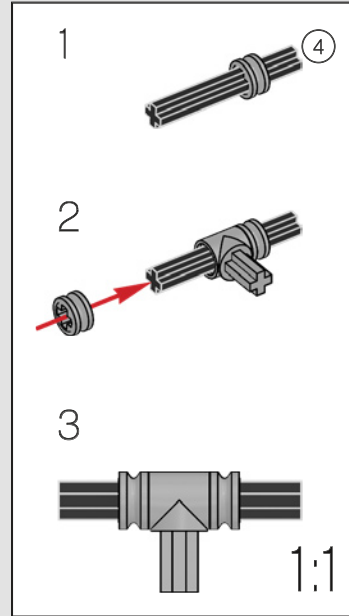
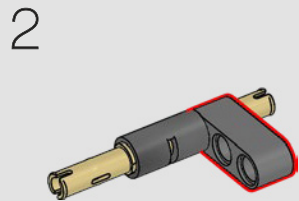
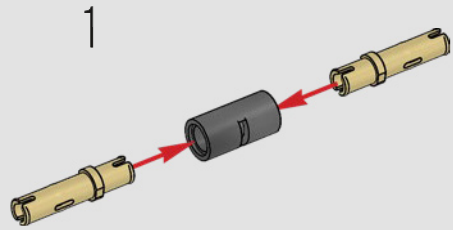

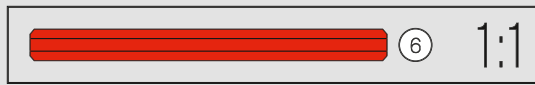
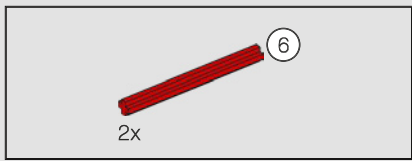

139

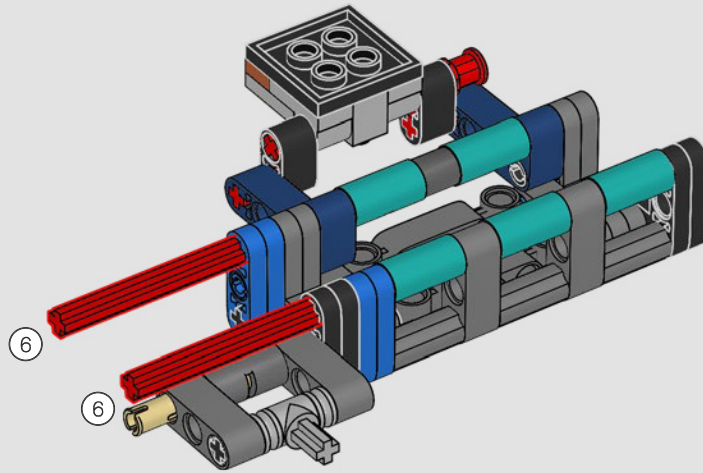

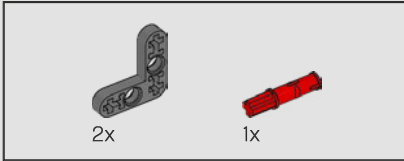
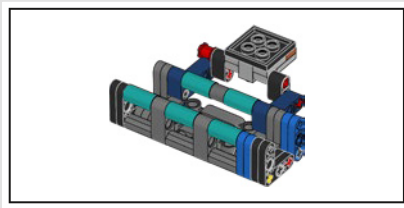

140

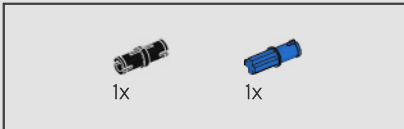
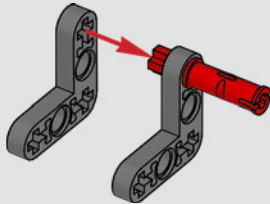

141

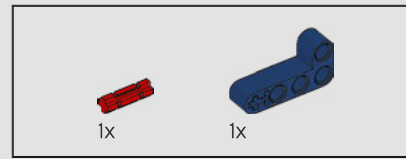
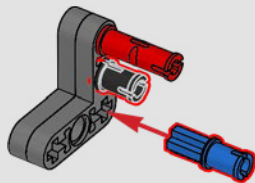

142

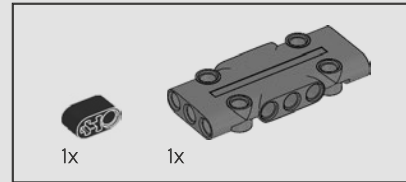
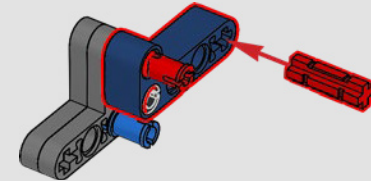

143

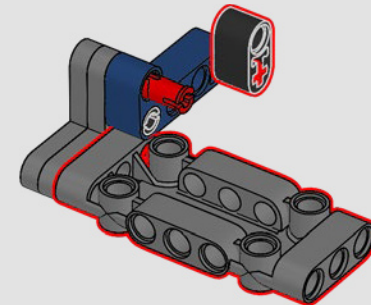

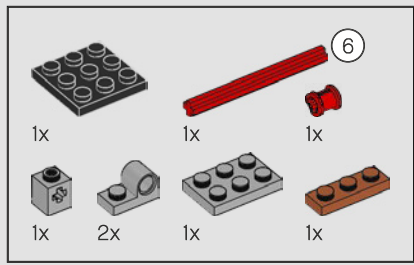

144

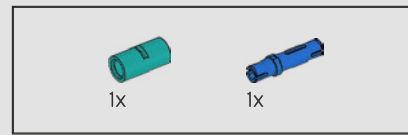
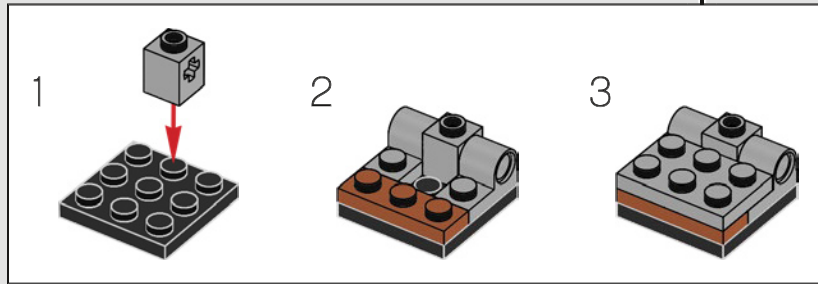
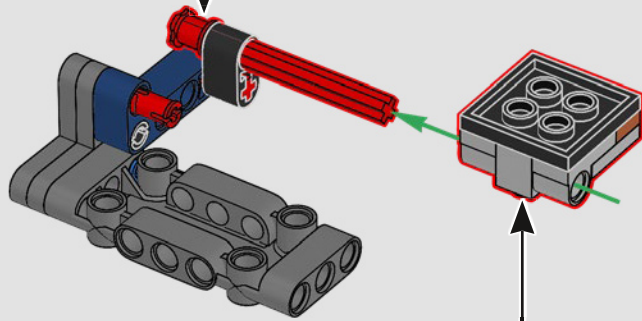
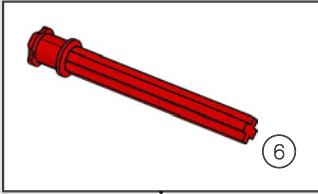

145

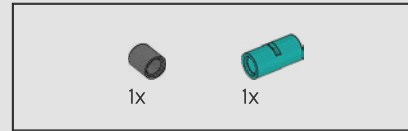
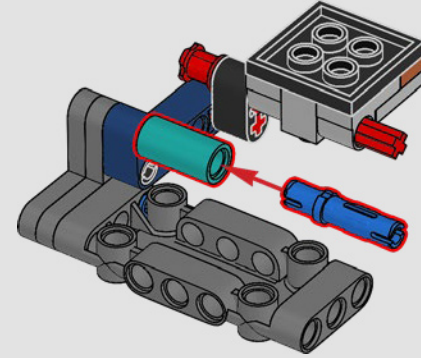

146

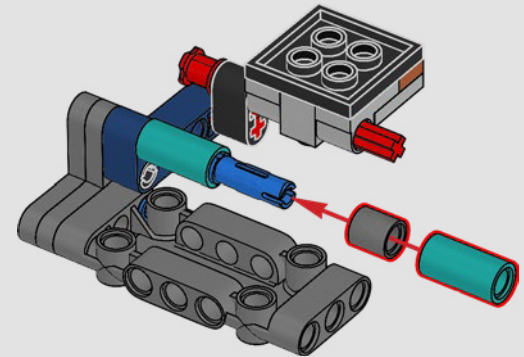

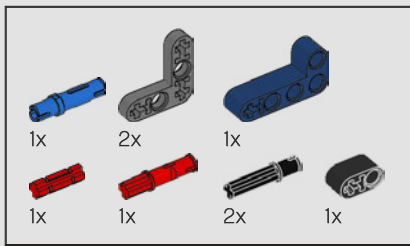

147

1

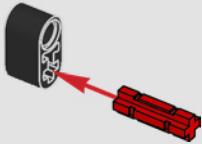

2

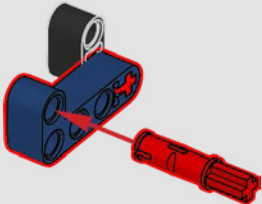

3

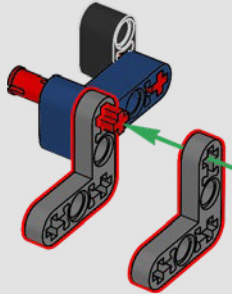

4

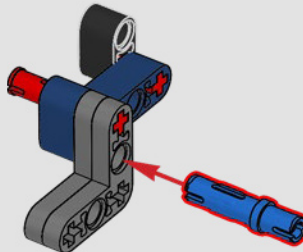

5

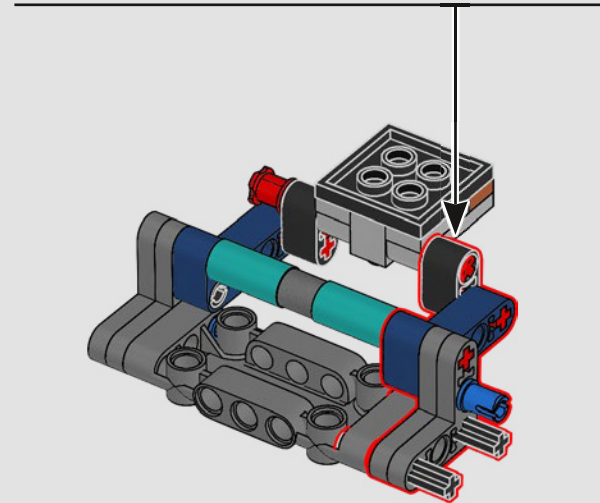
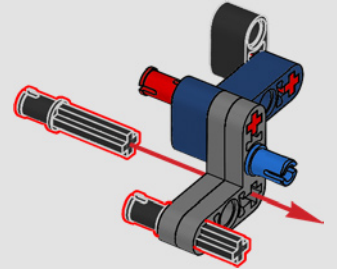

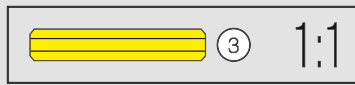
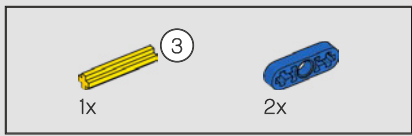

148

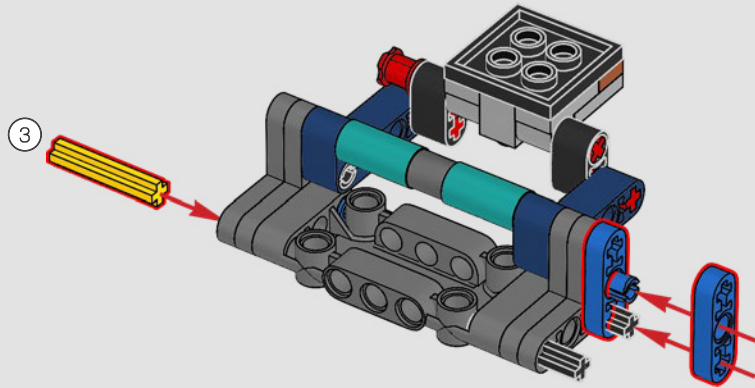

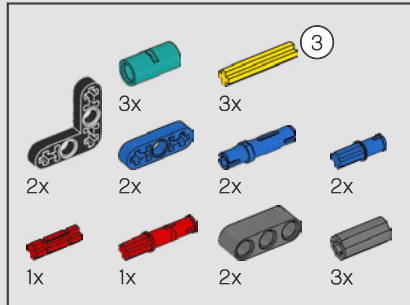
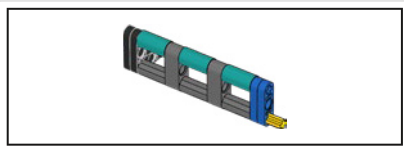

149

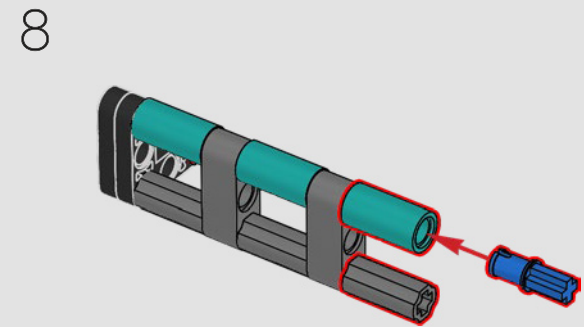
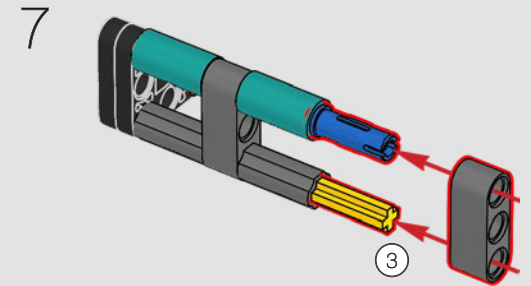
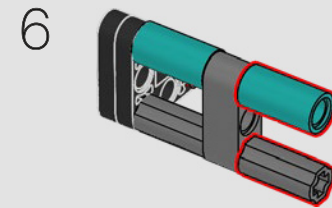
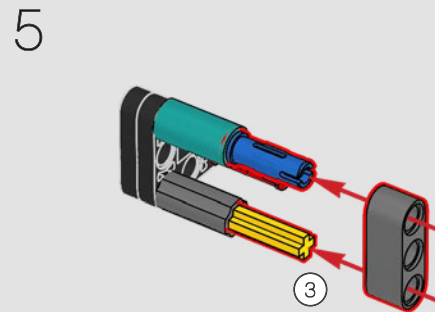
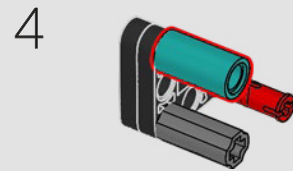
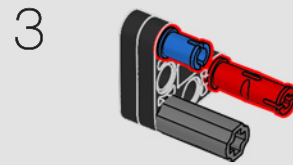
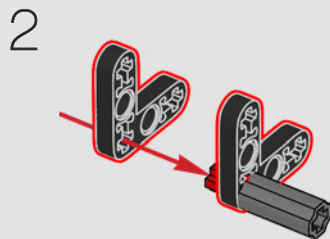
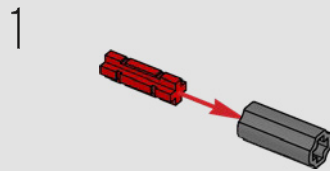

9

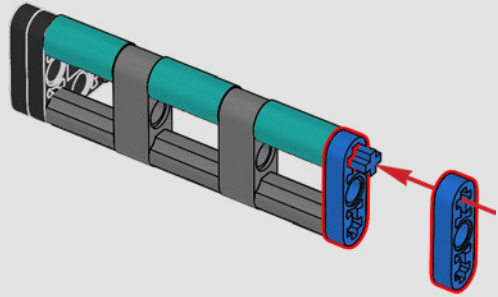

10

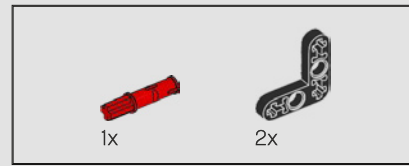
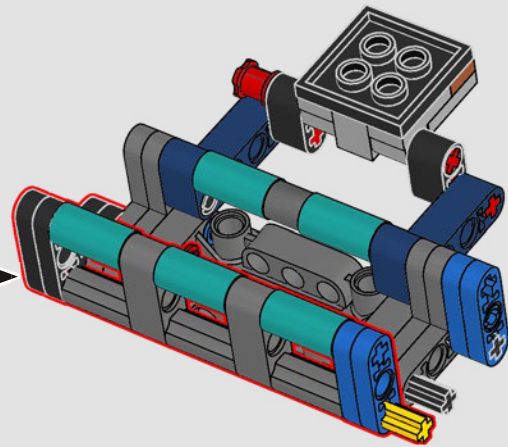
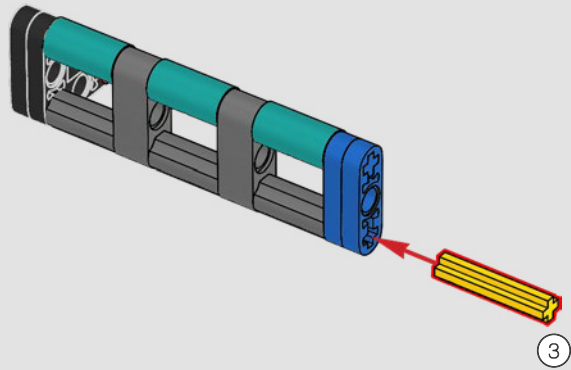

150

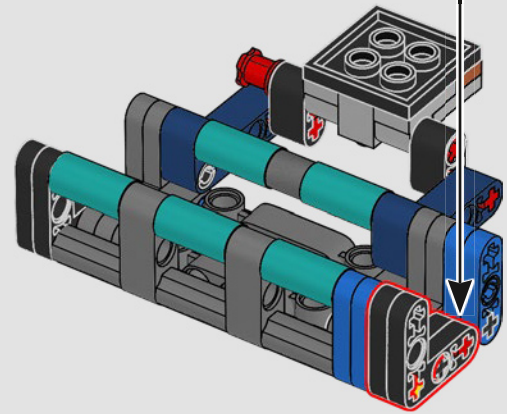
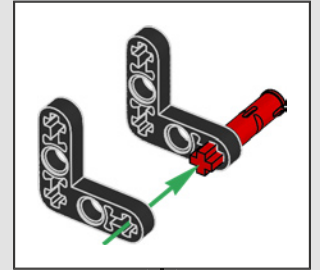

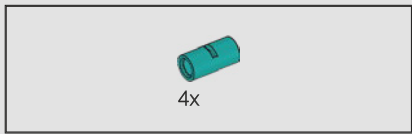

151

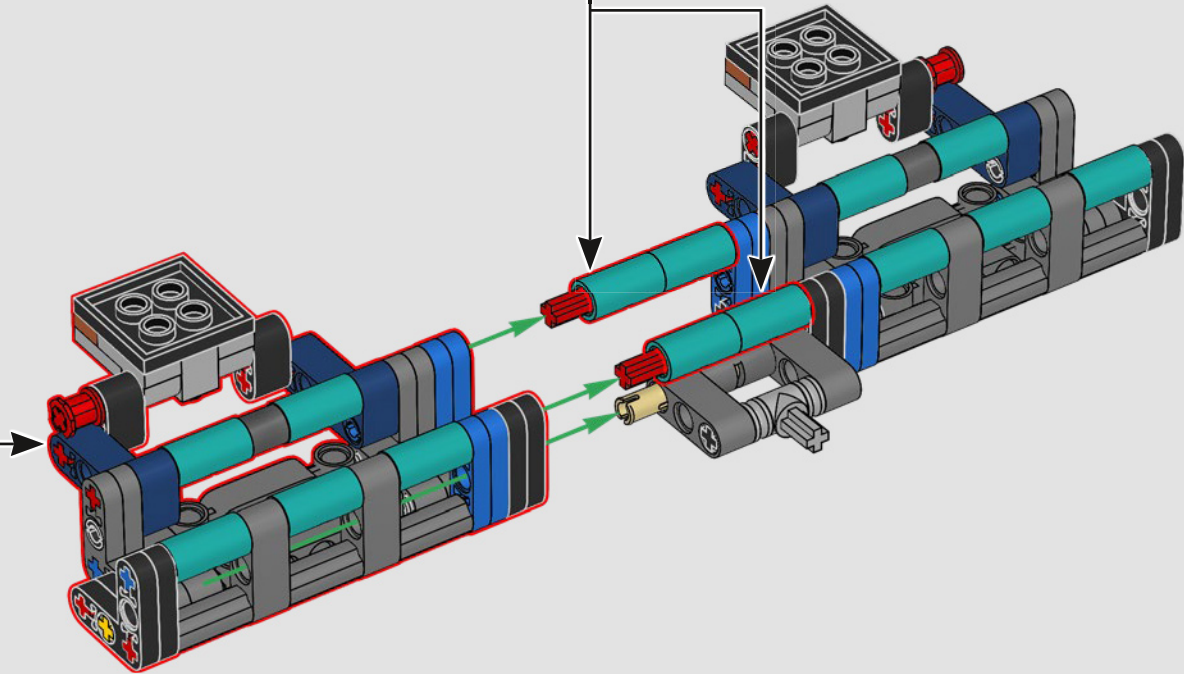
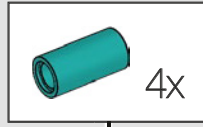

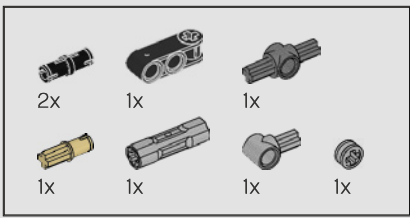

152

1

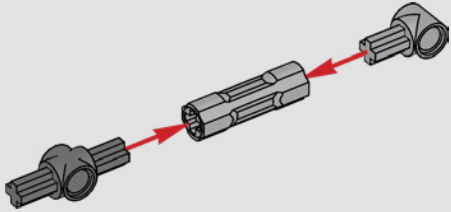

2

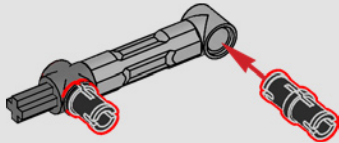

3

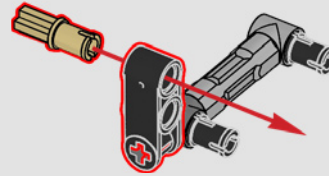

4

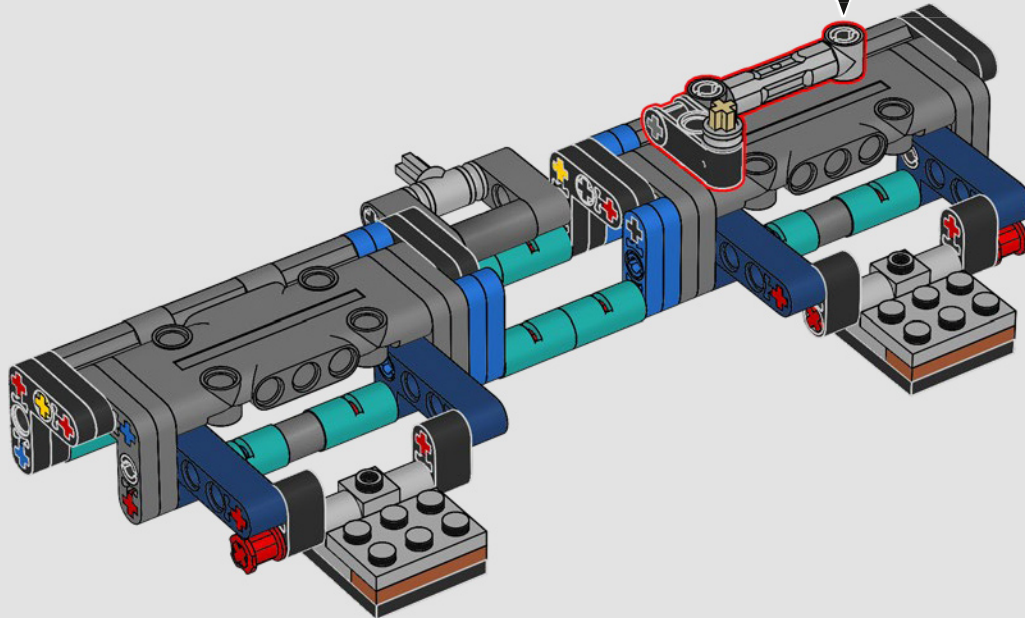
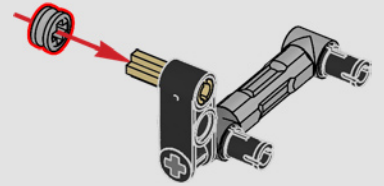

153

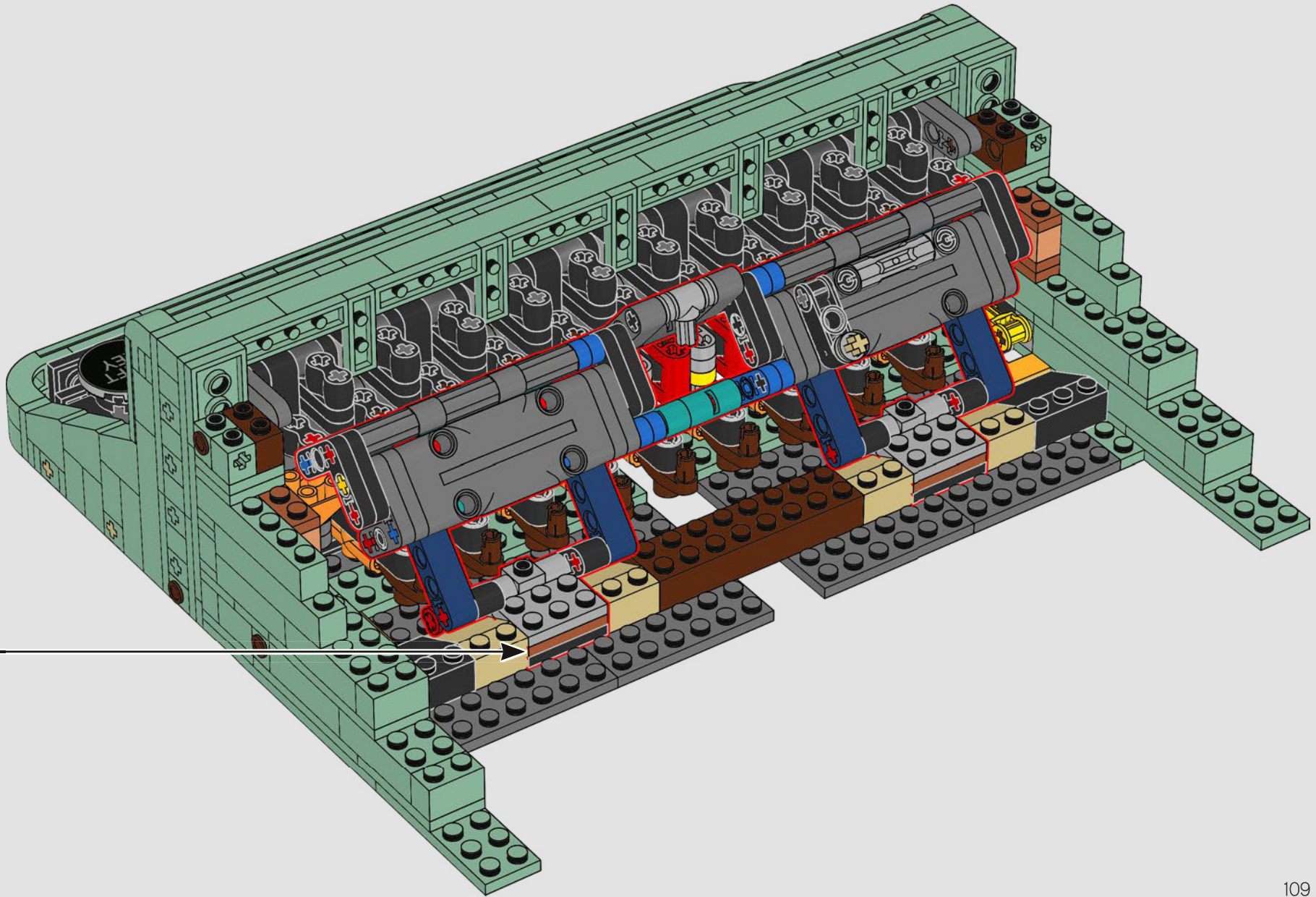

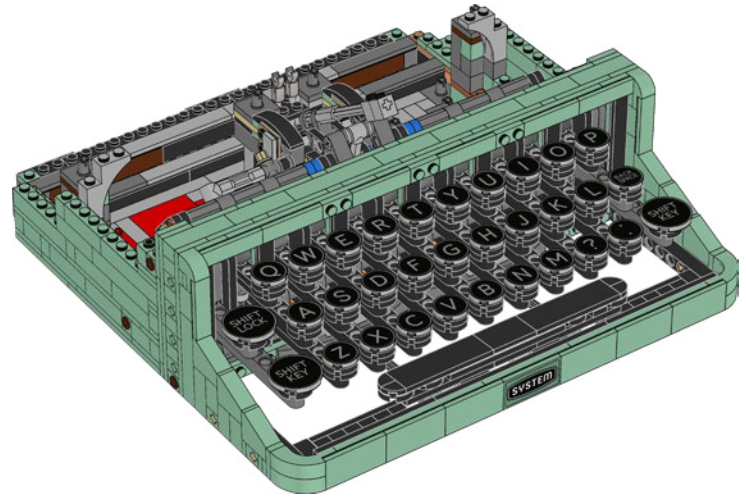
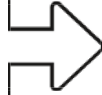
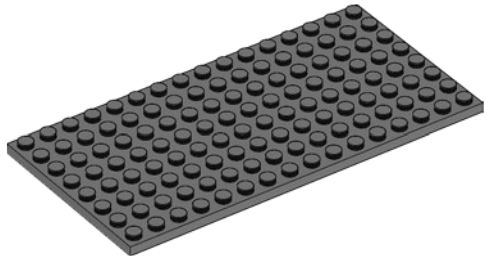

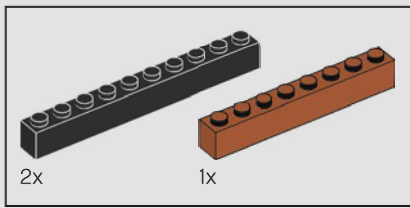

154

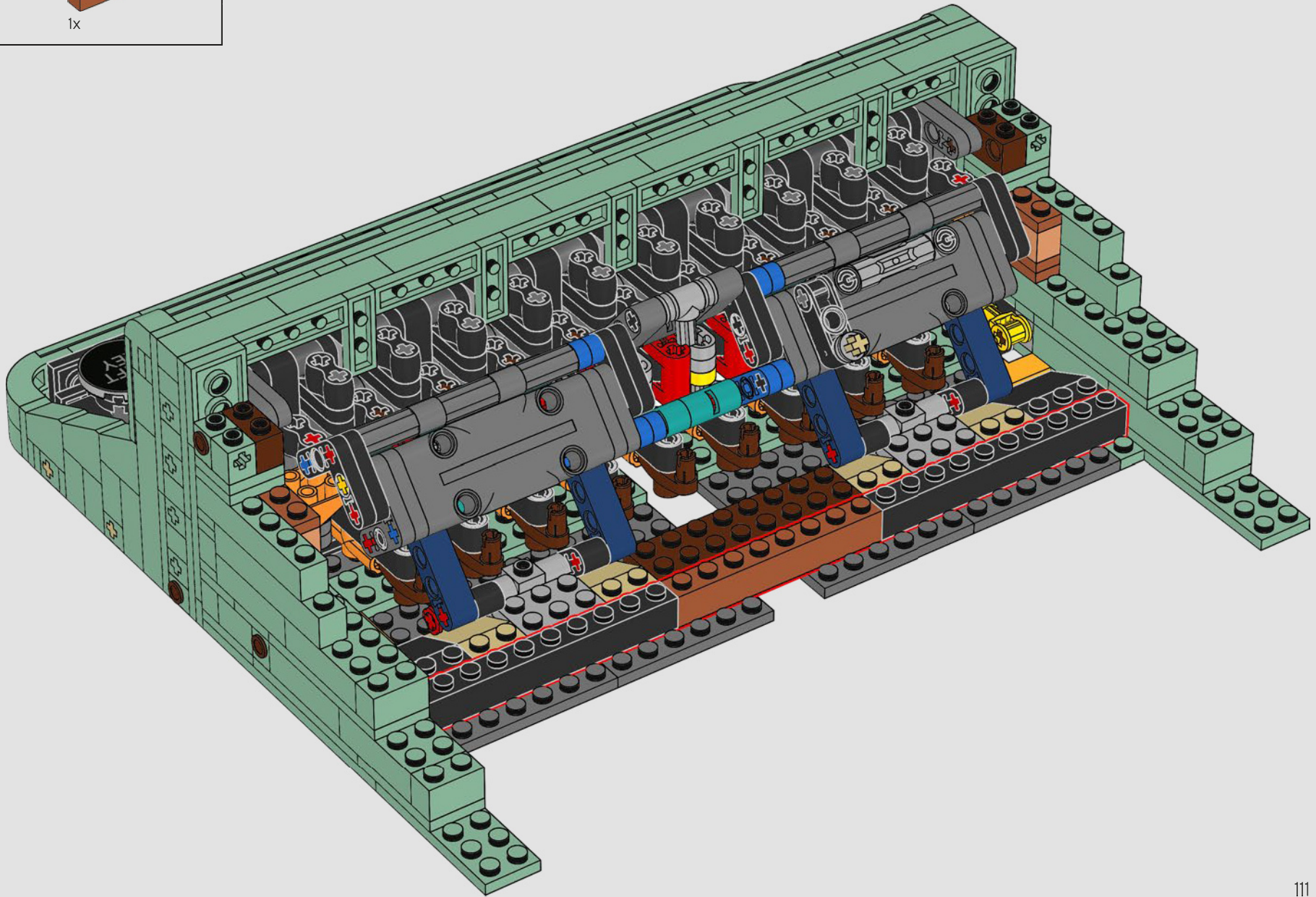

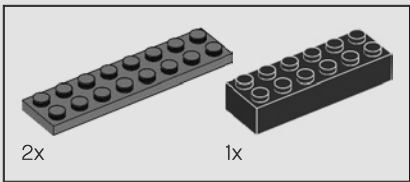

155

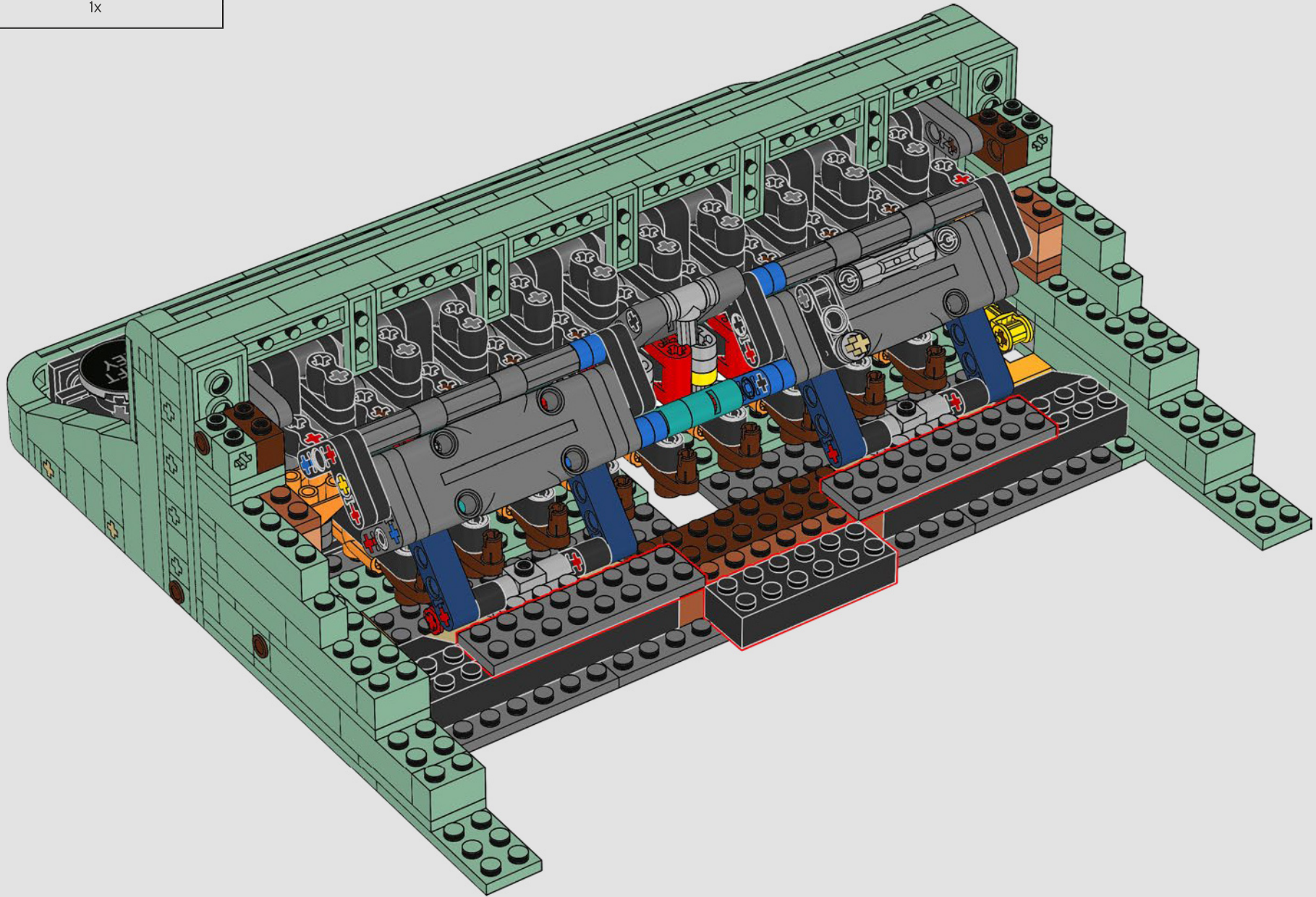

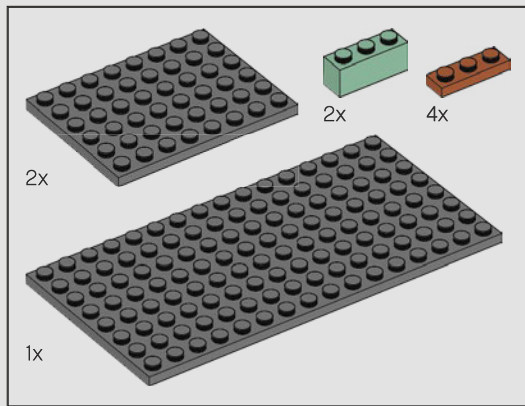

156

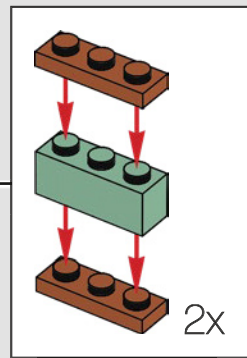
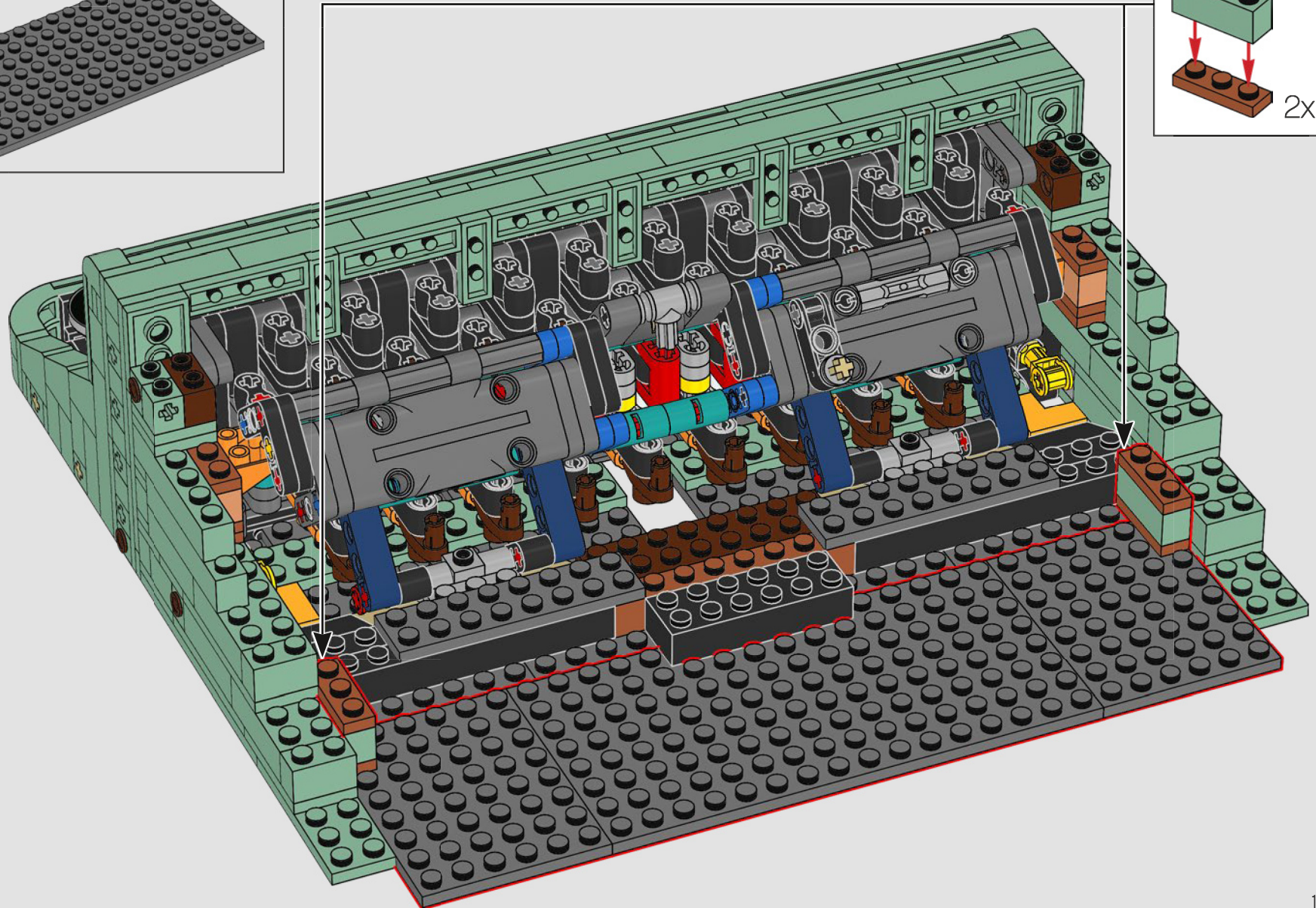

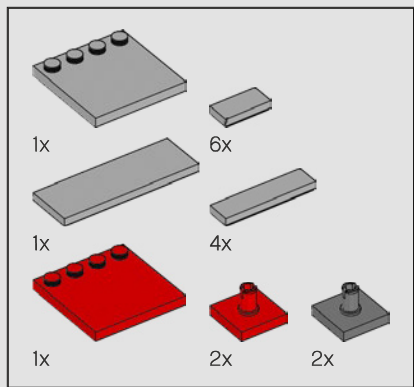

157

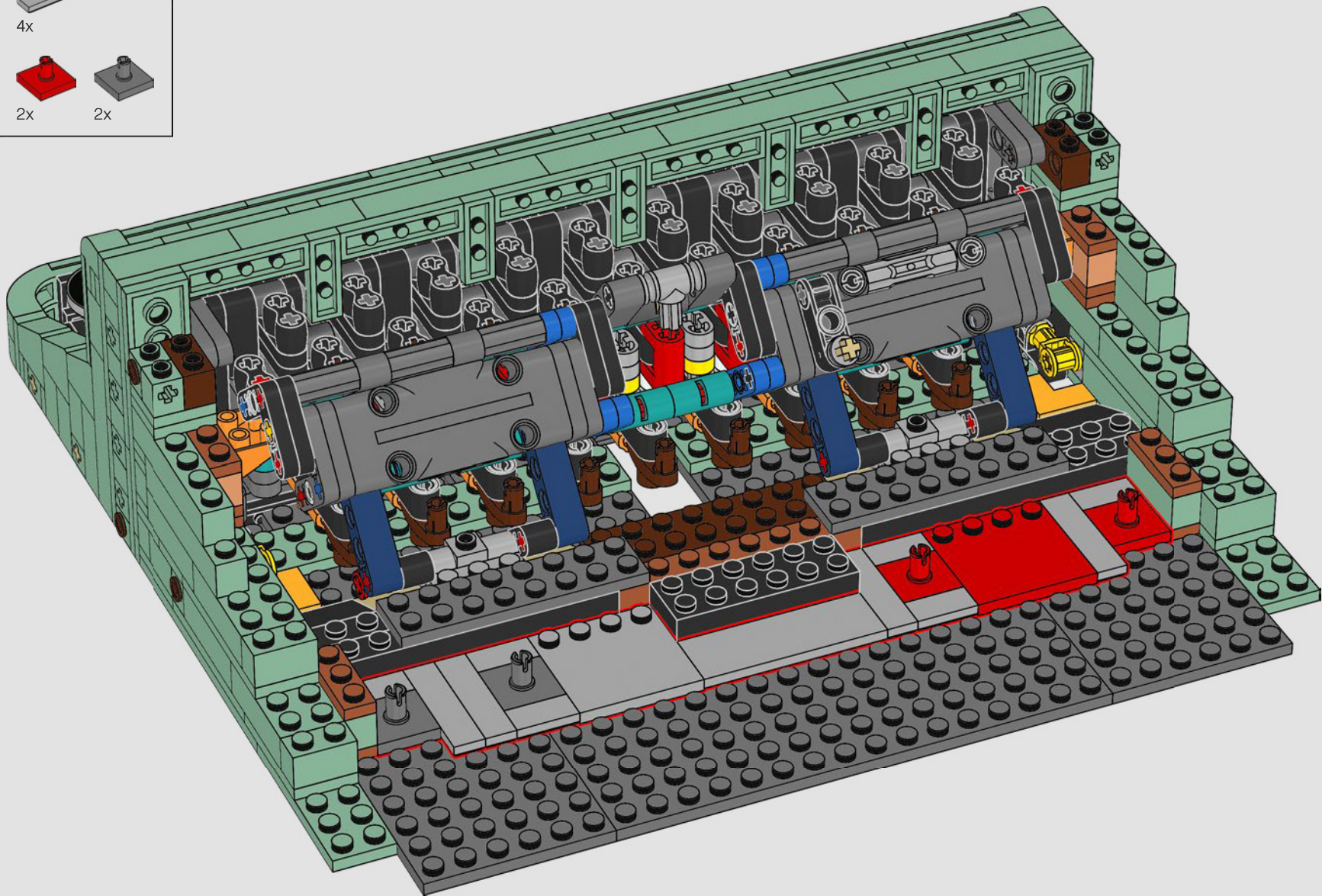

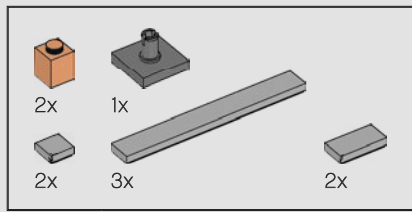

158

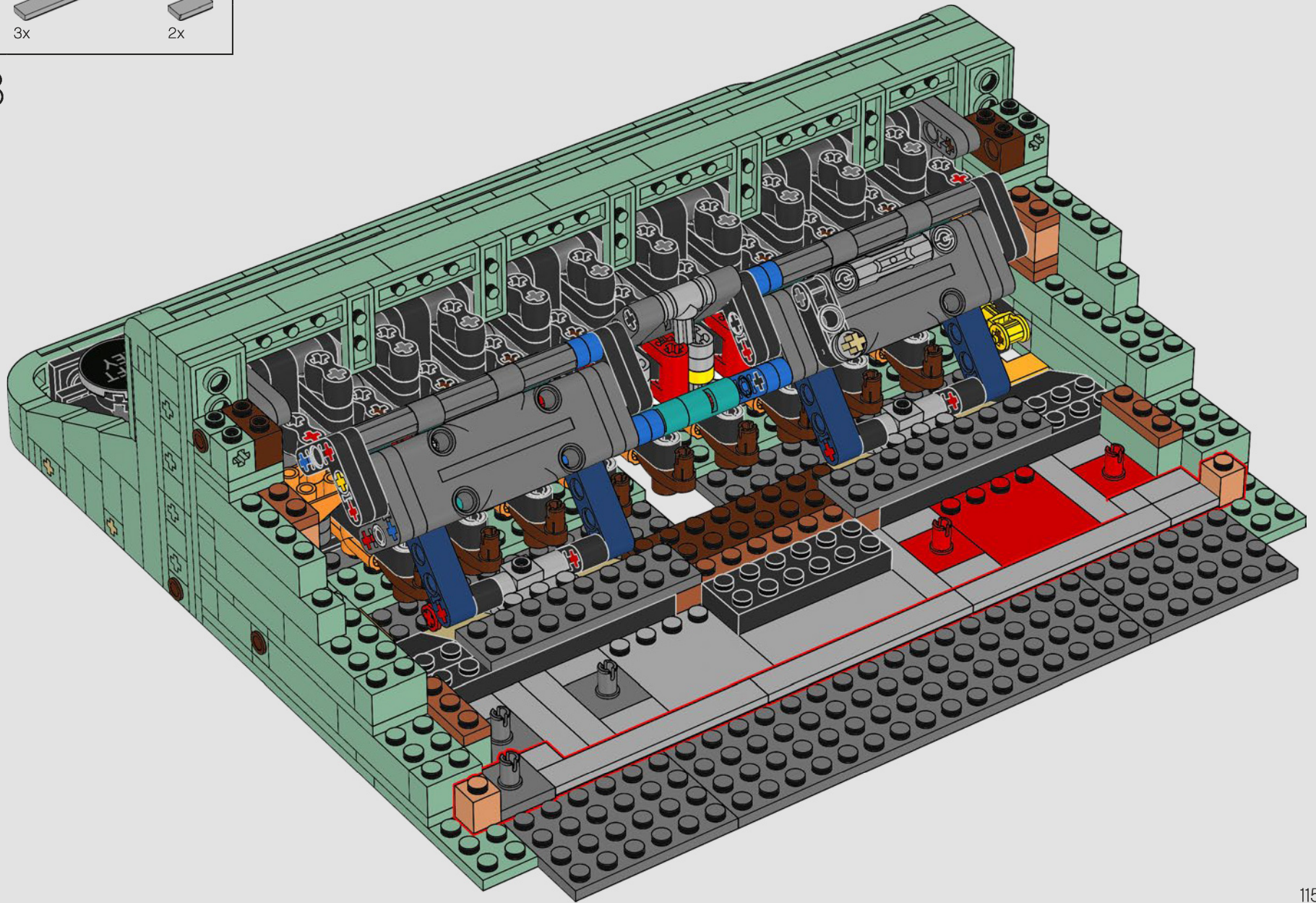

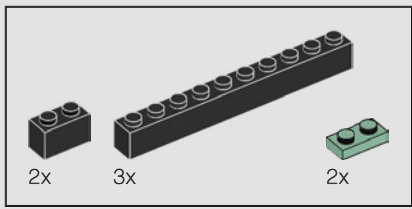

159

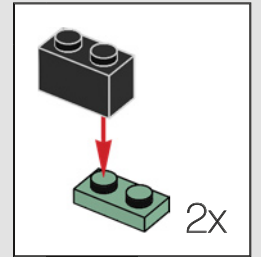
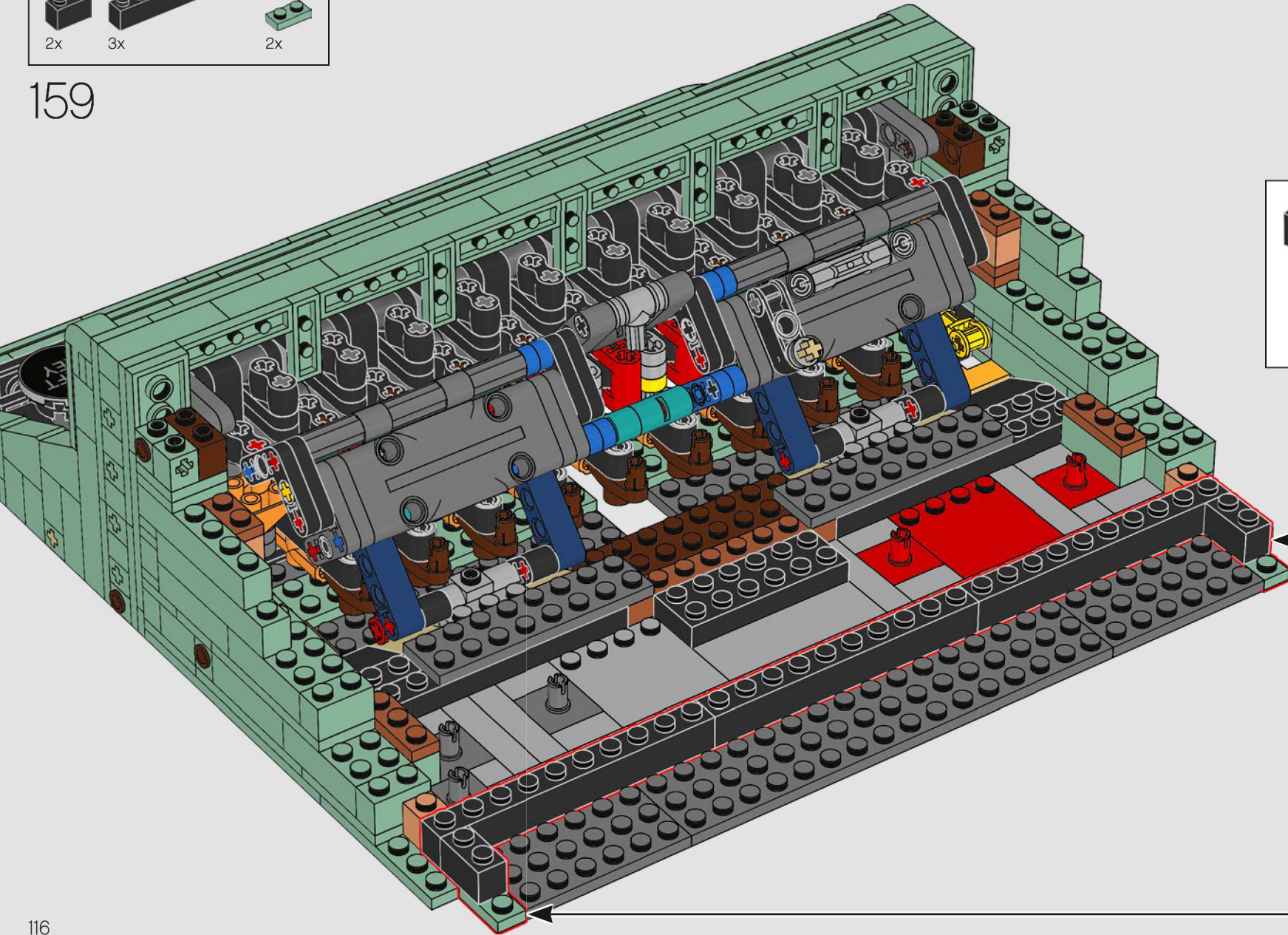

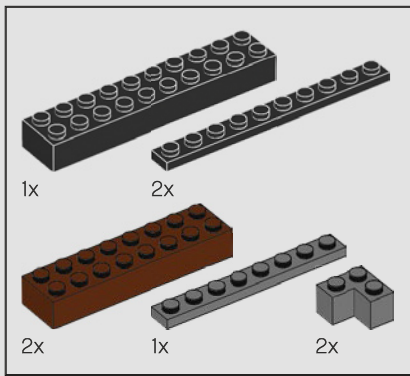

160

1

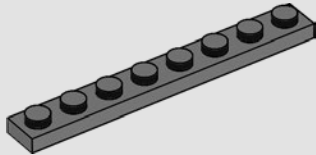

2

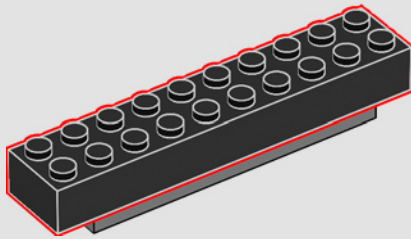

3

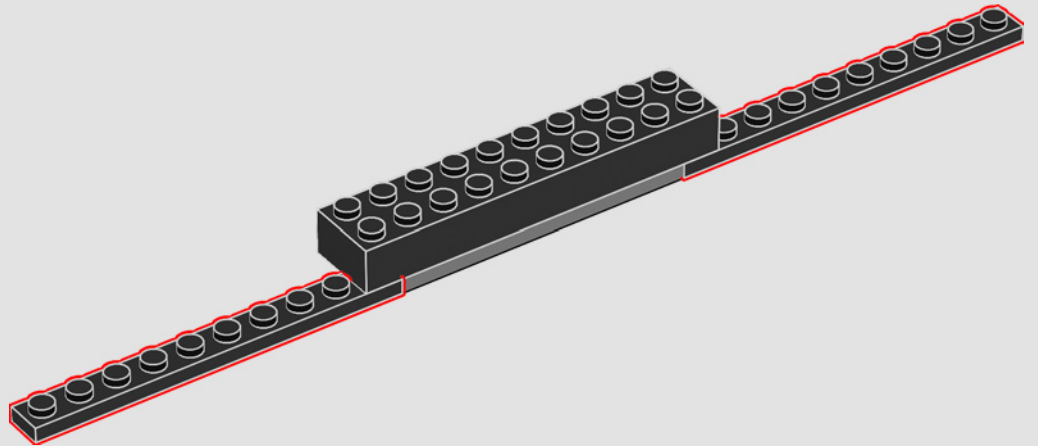

4

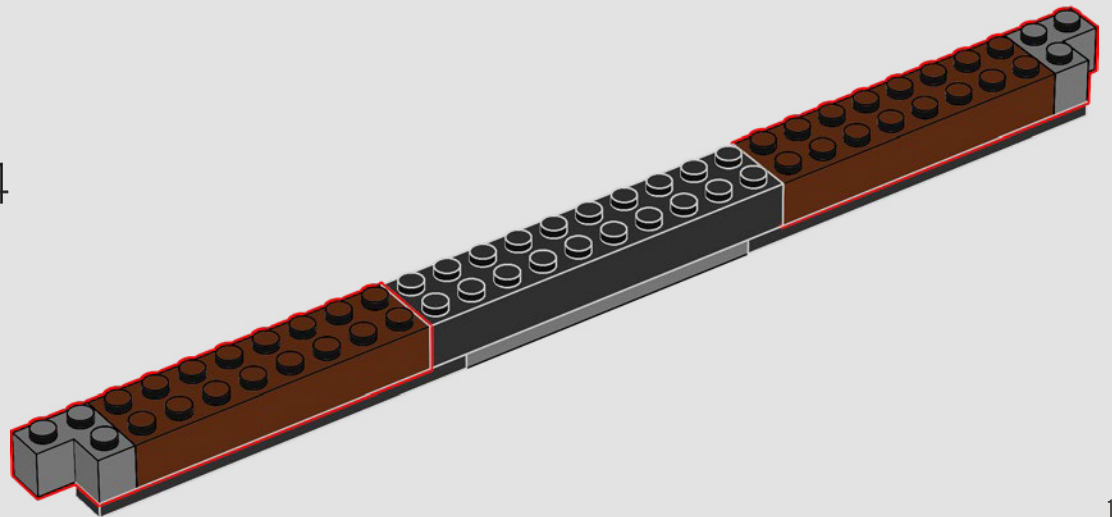

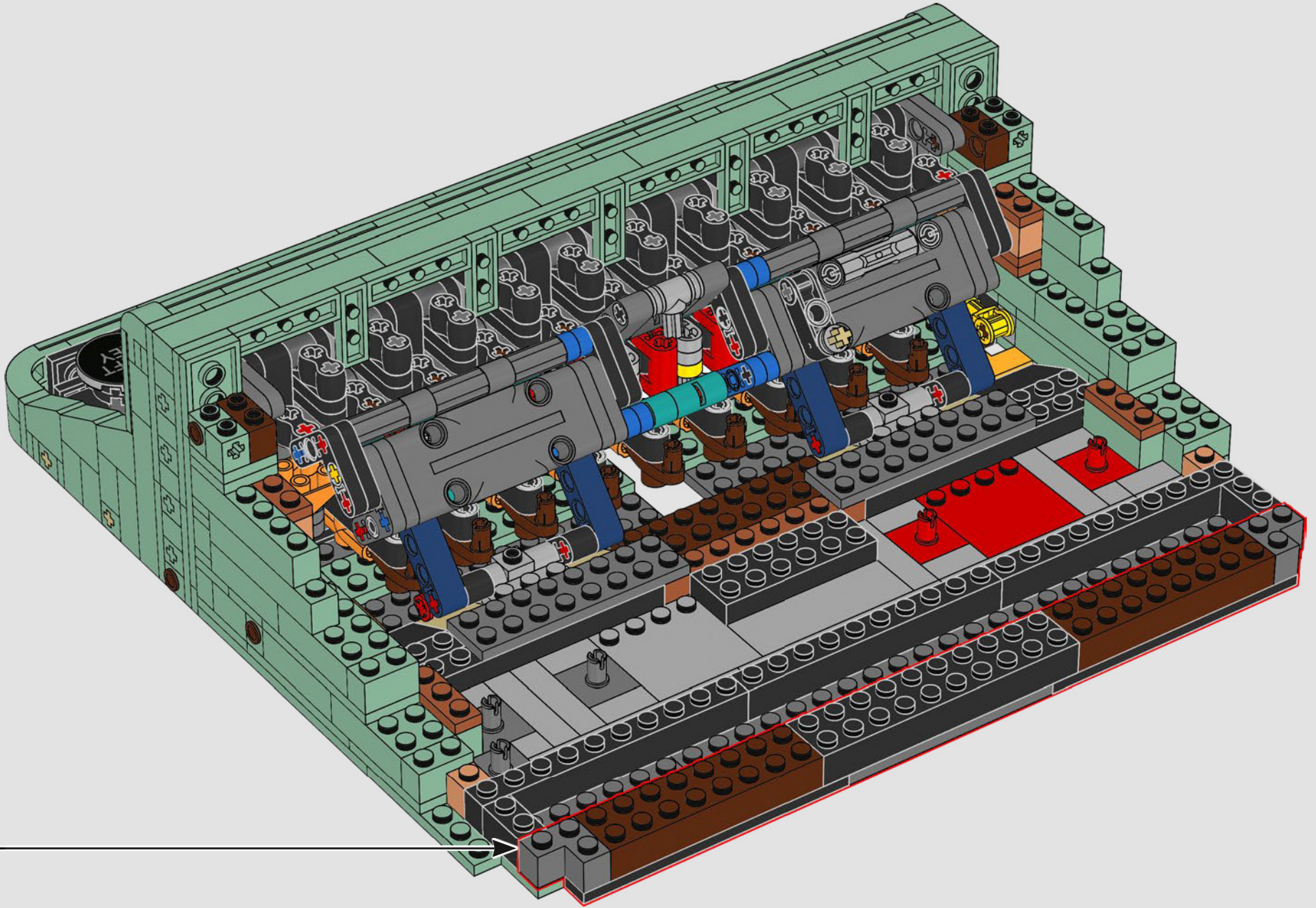

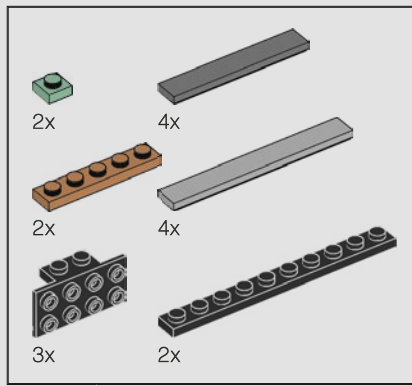

161

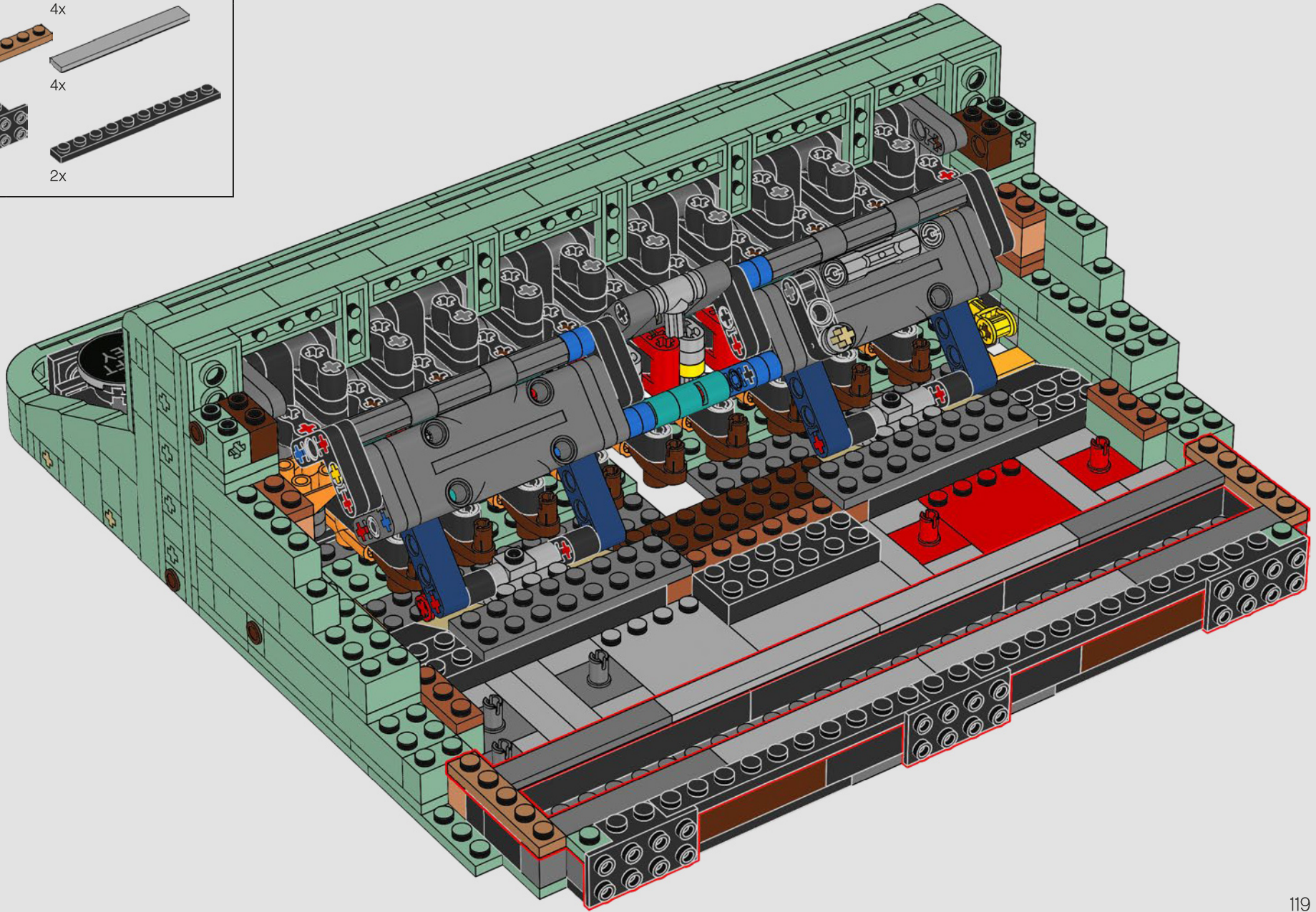

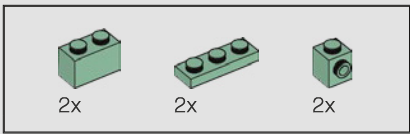

162

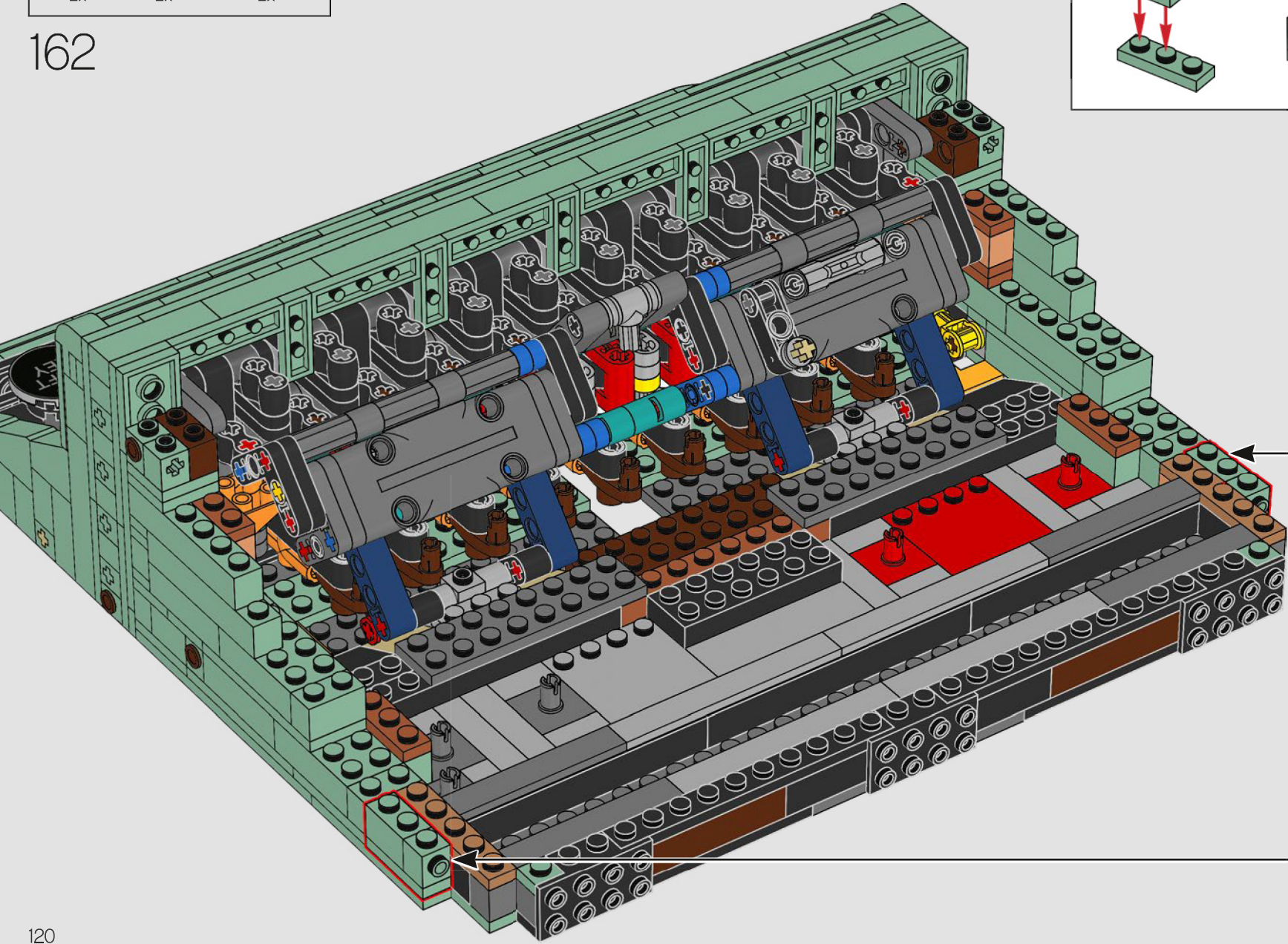
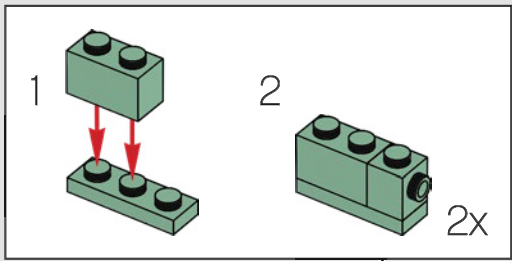

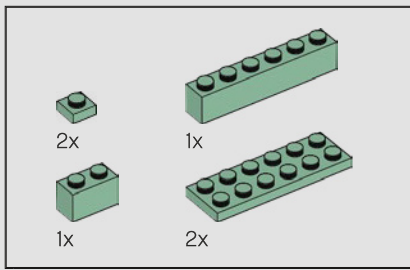

163

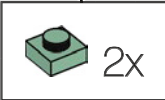
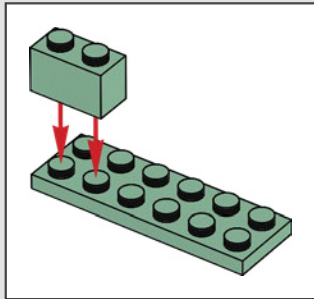
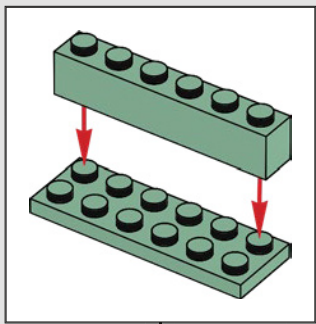
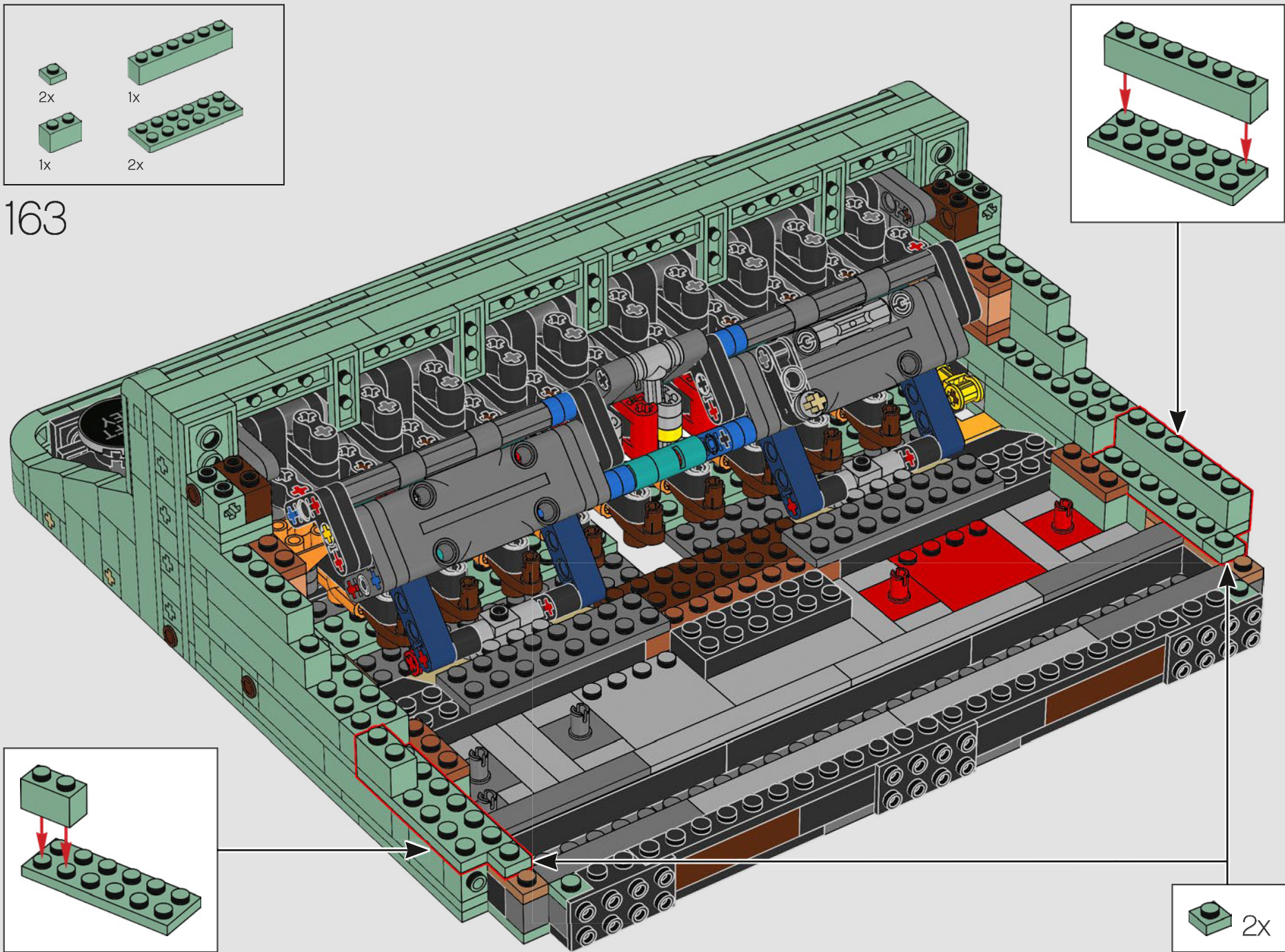

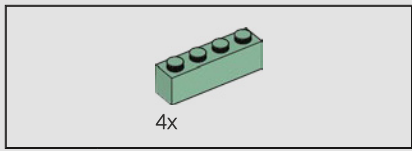

164

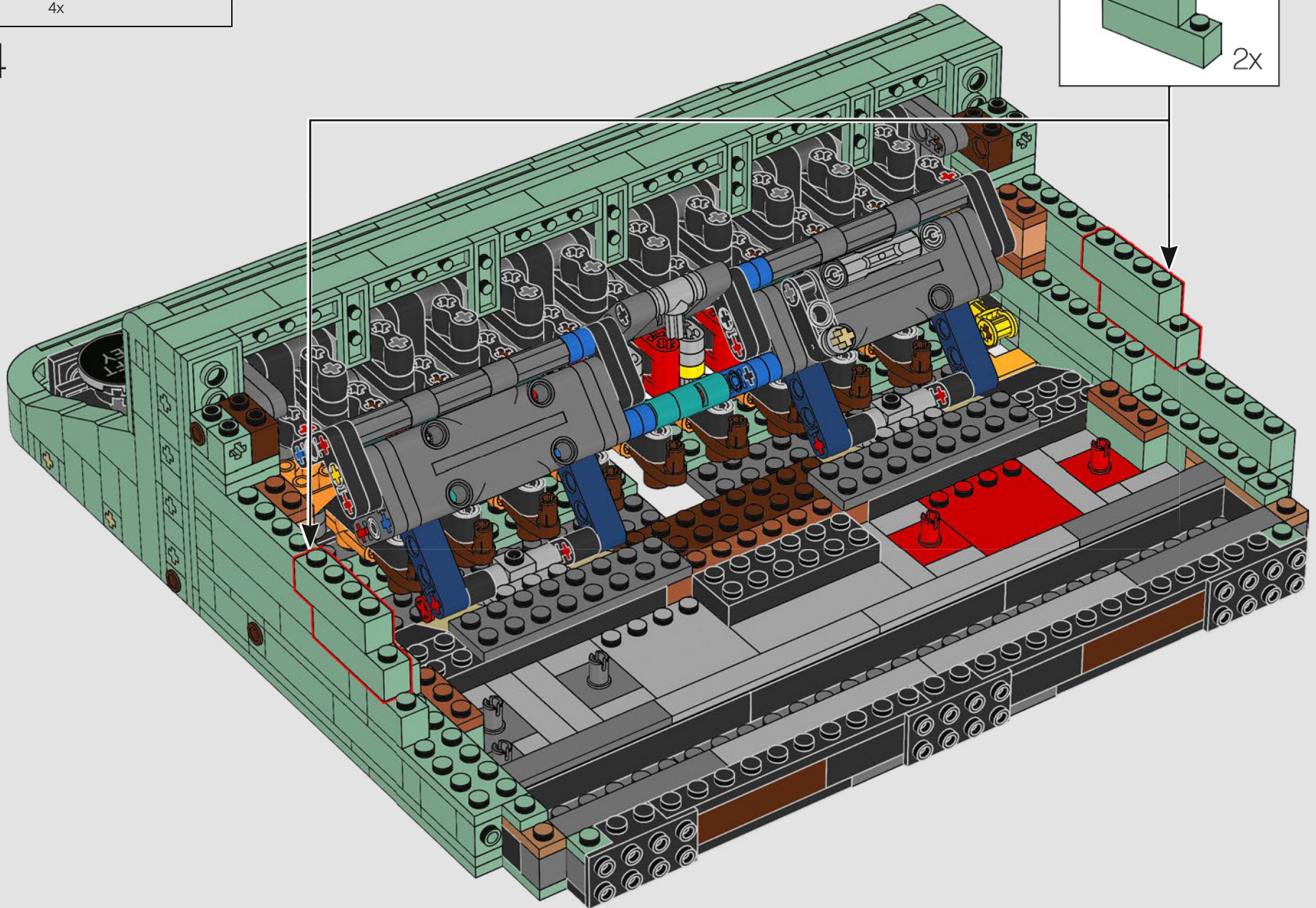
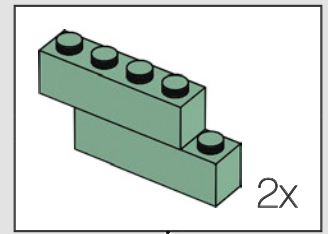

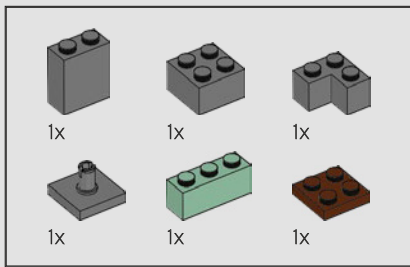

165

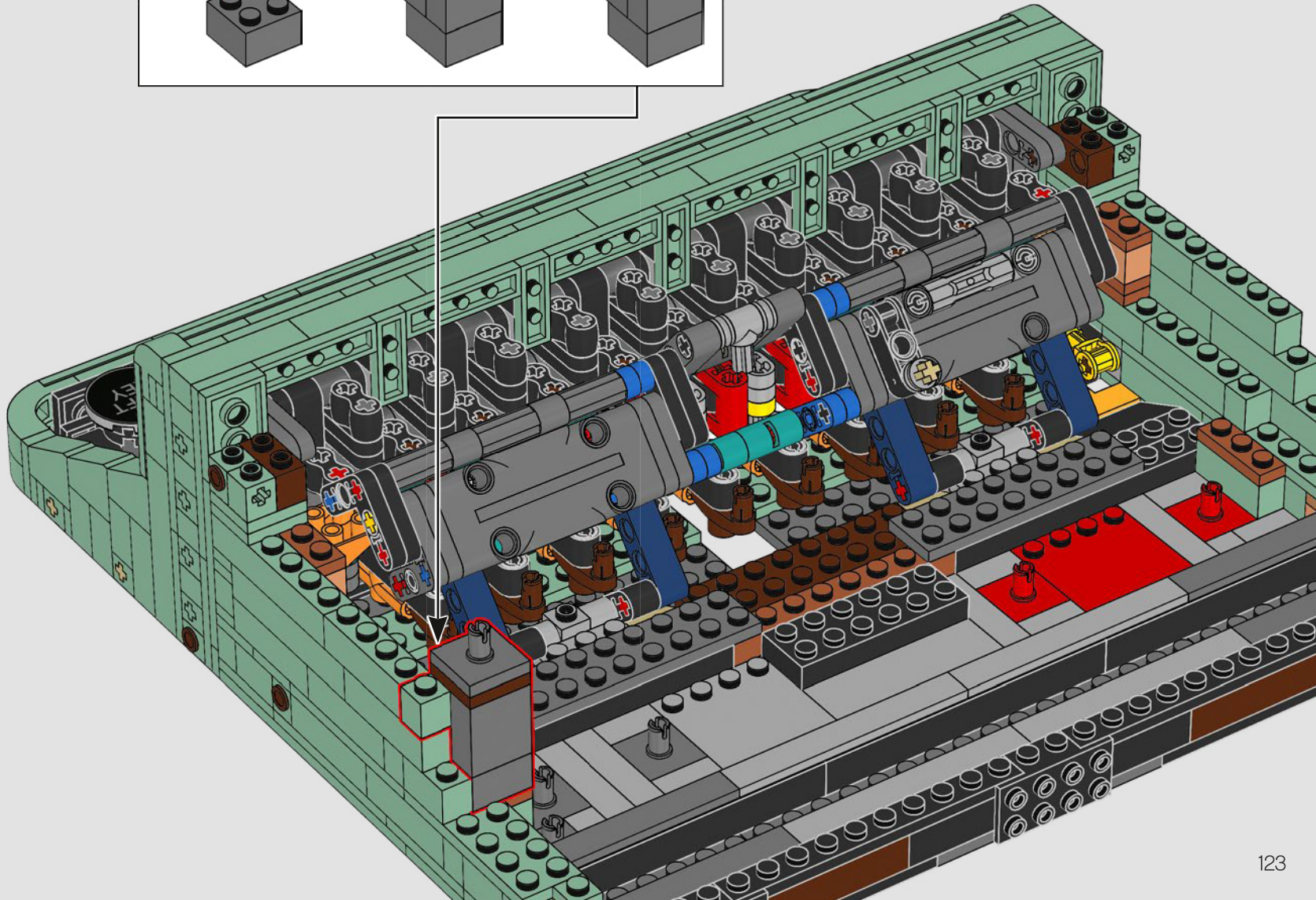
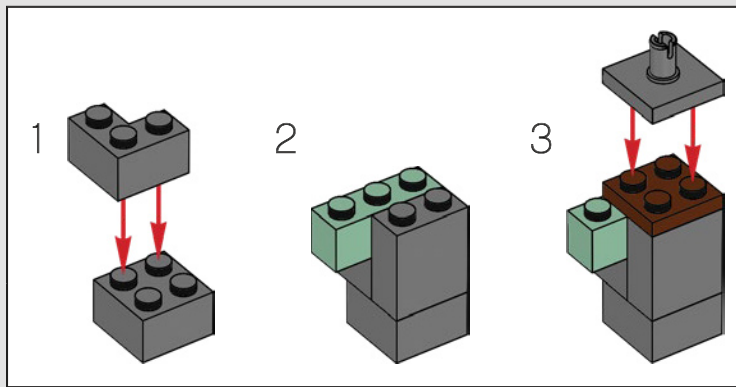

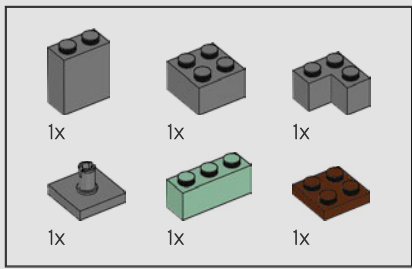

166

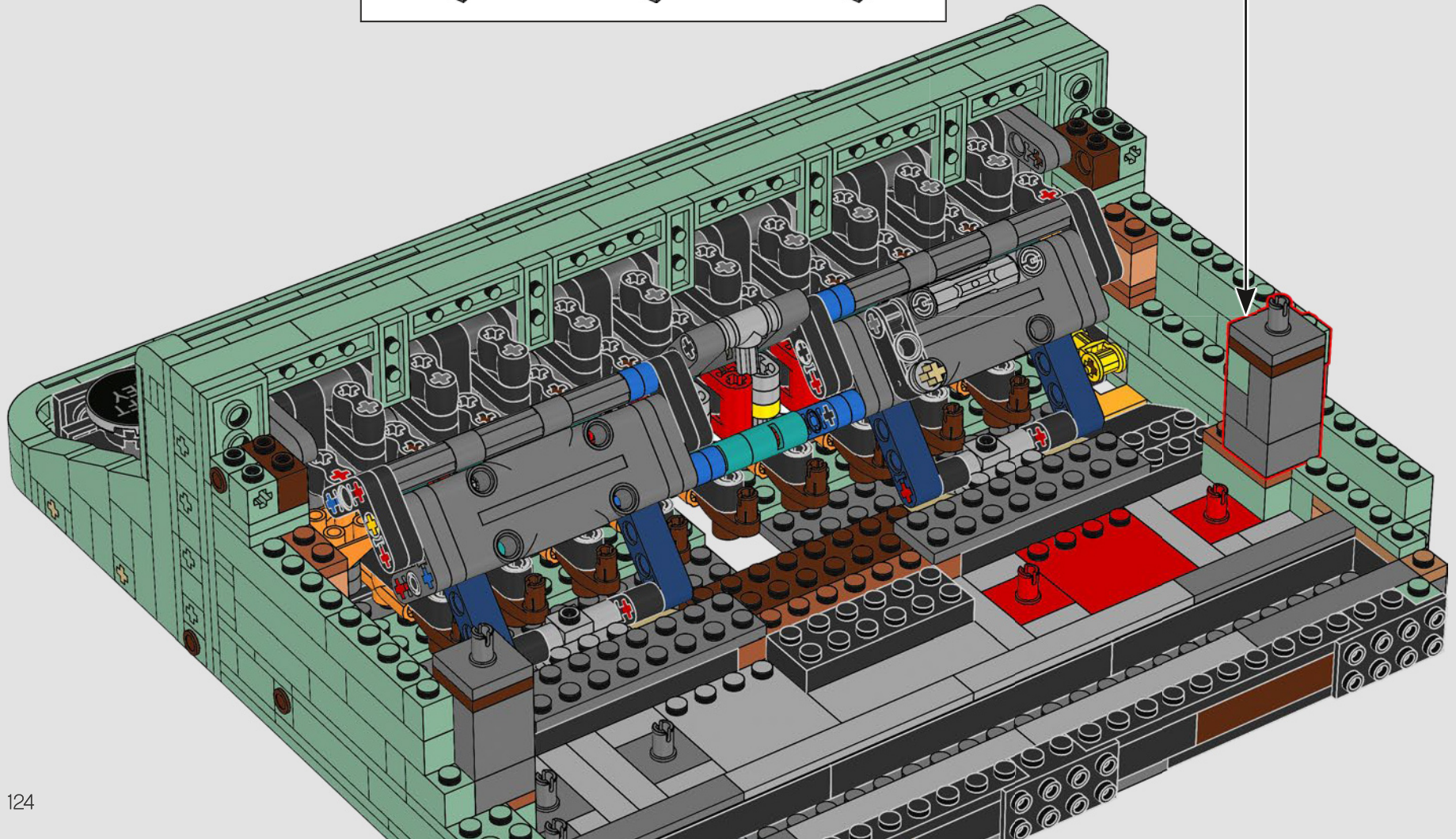
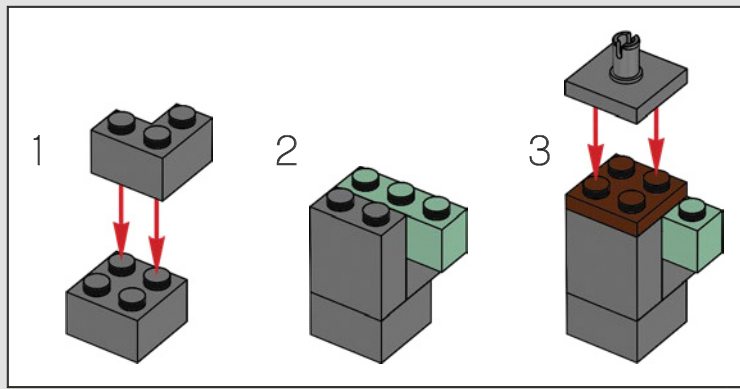

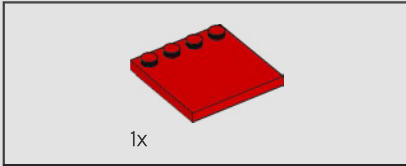
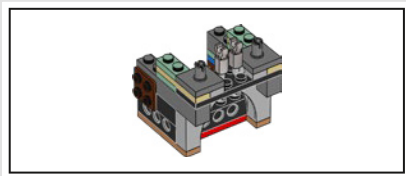

1x

167

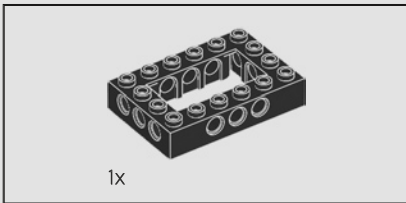
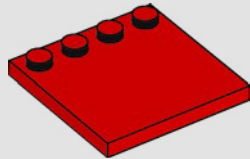

1x

168

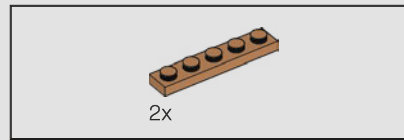
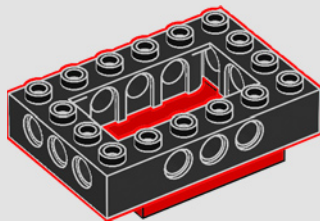

2x

169

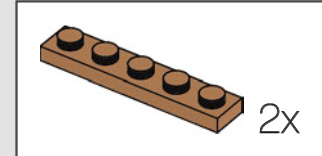

2x

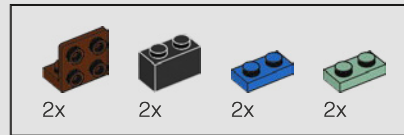
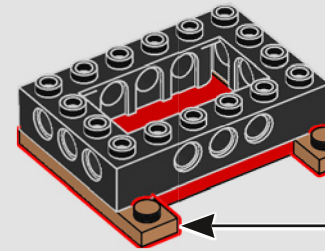

2x

2x

2x

2x

170

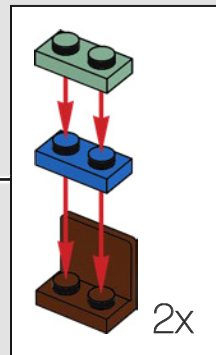

2x

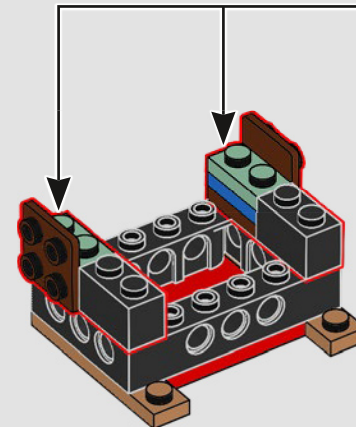

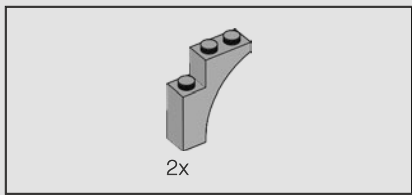

171

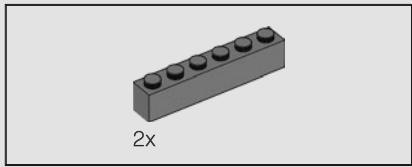
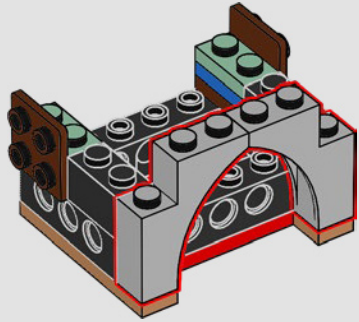

172

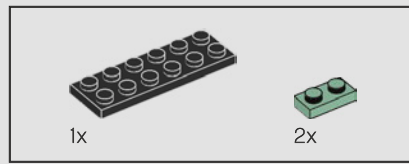
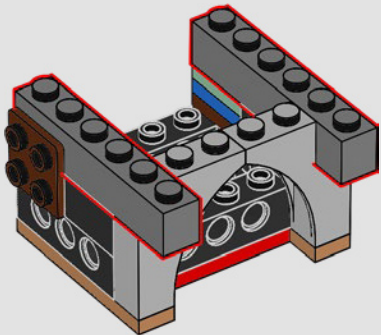

173

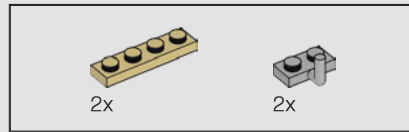
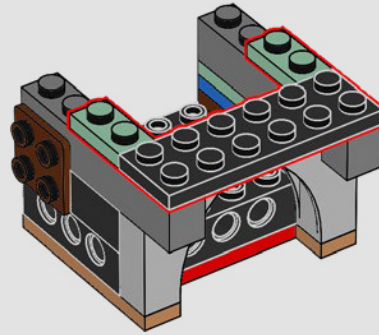

174

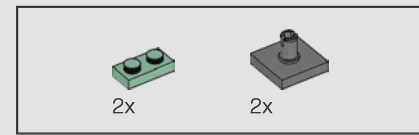
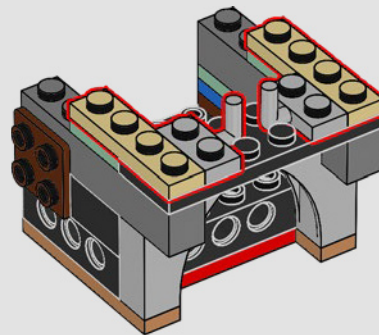

175

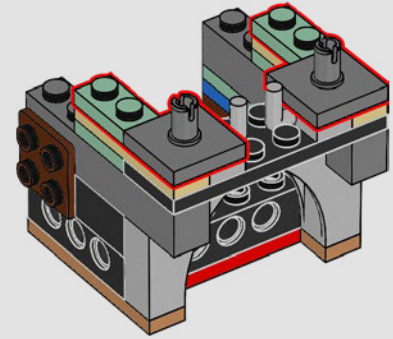

176

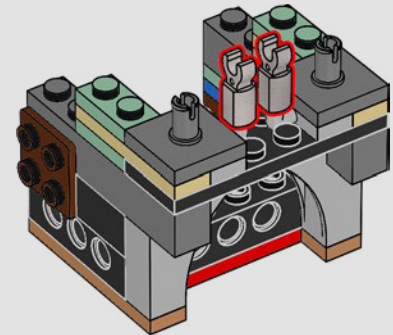

177

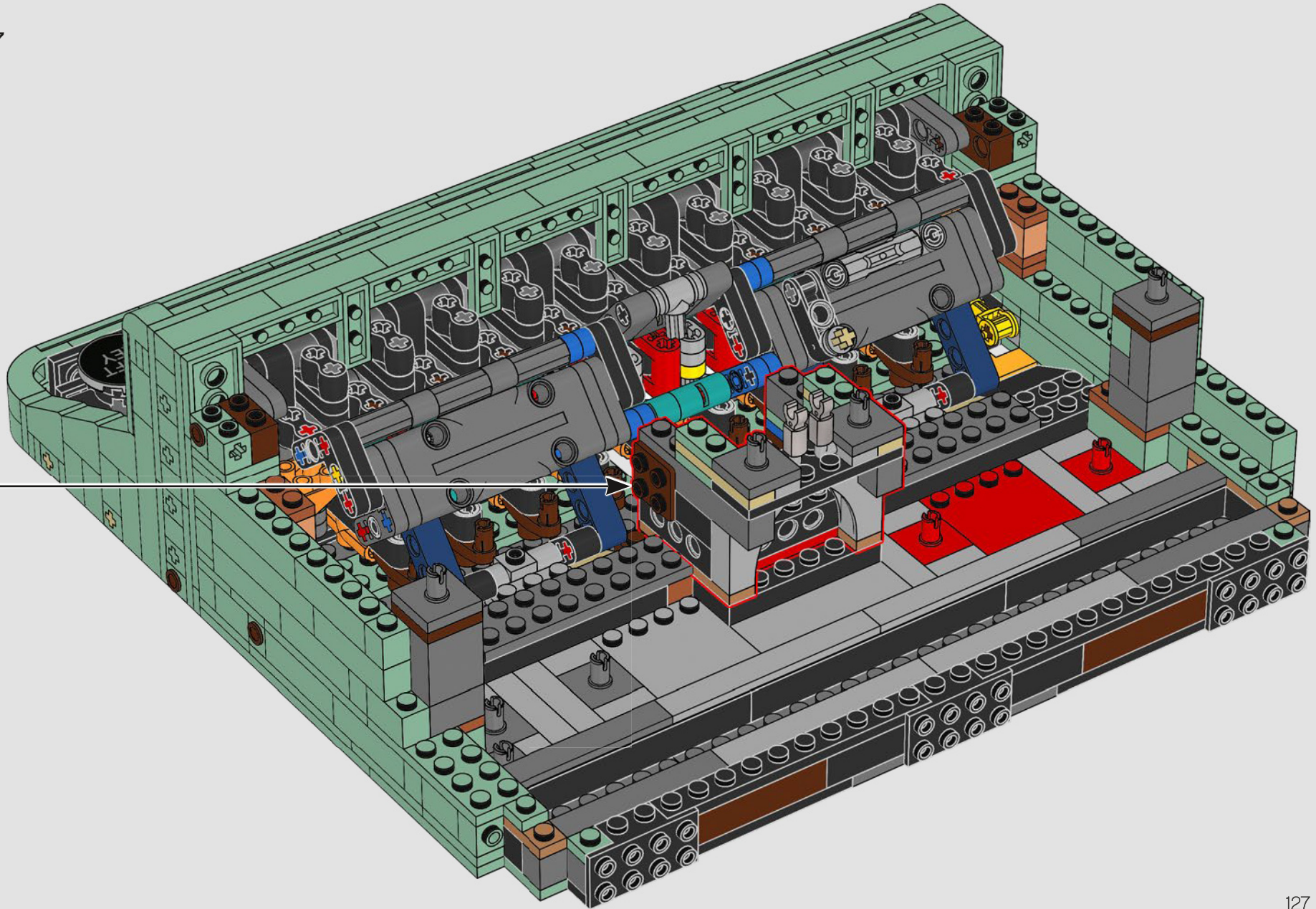

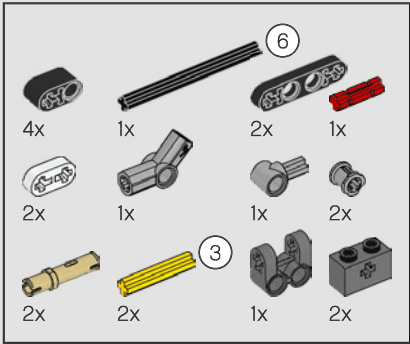

178

1

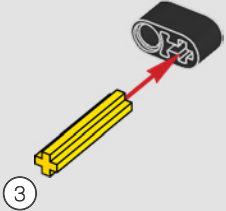

128

2

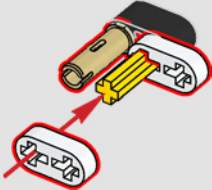

3

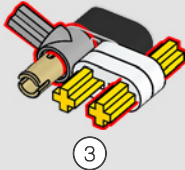

4

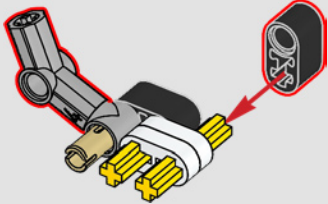

5

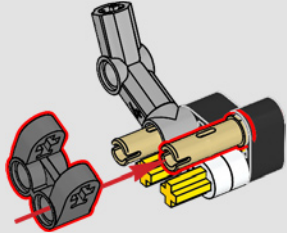

6

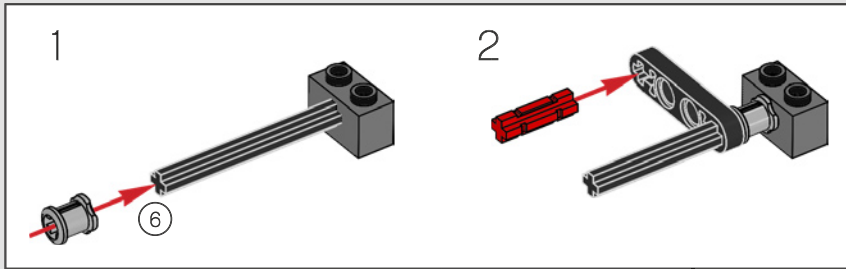
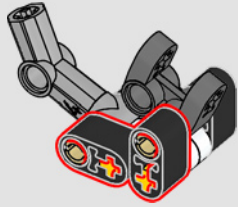

7

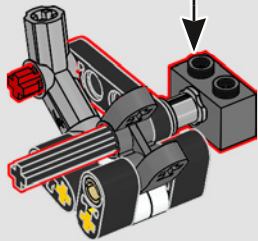

8

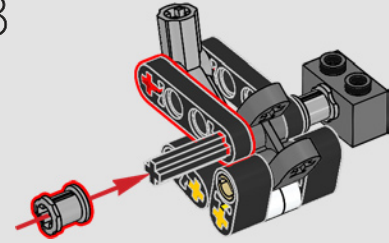

9

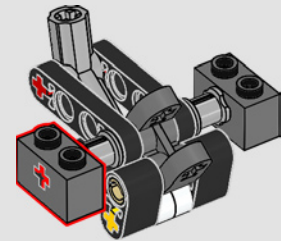

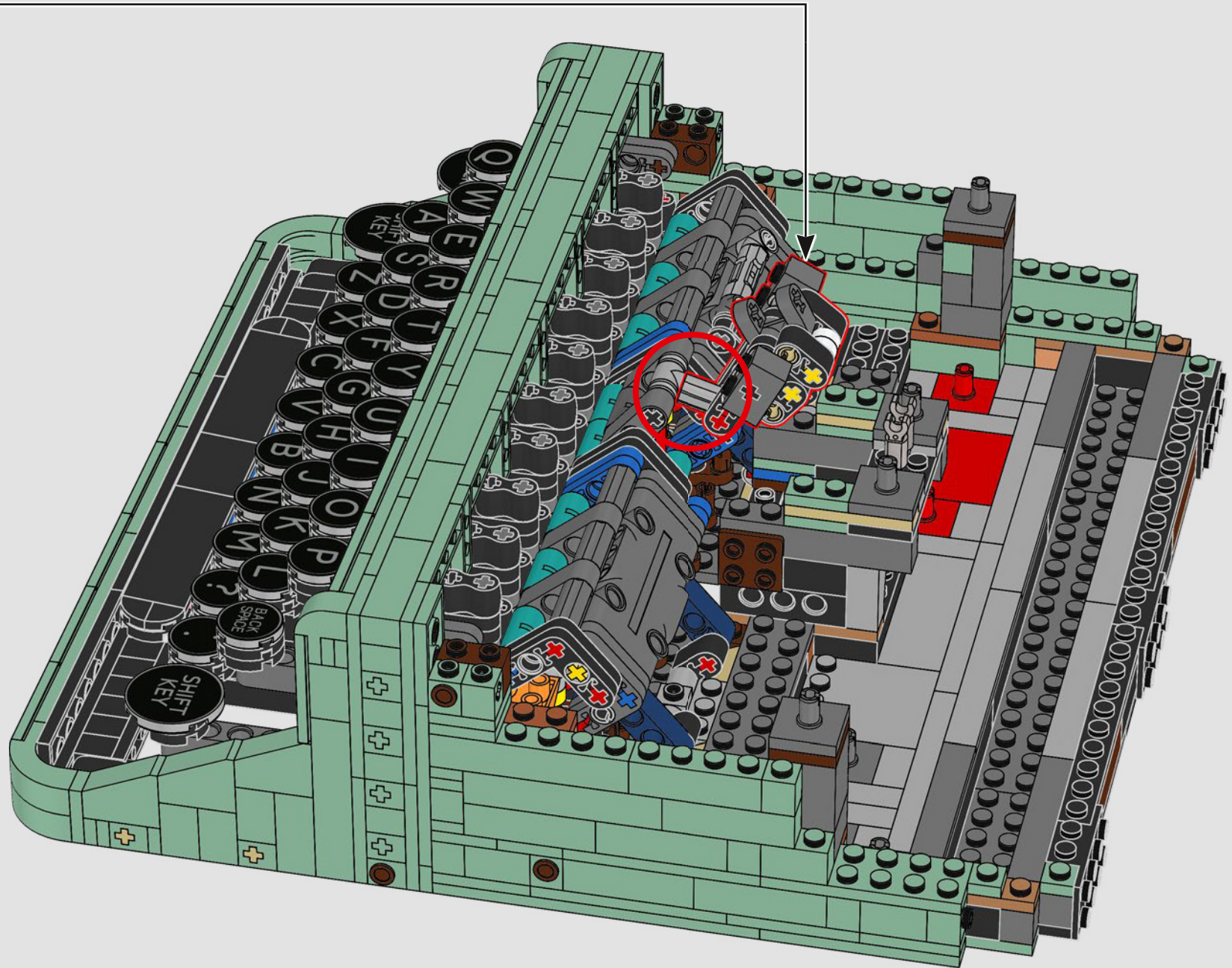

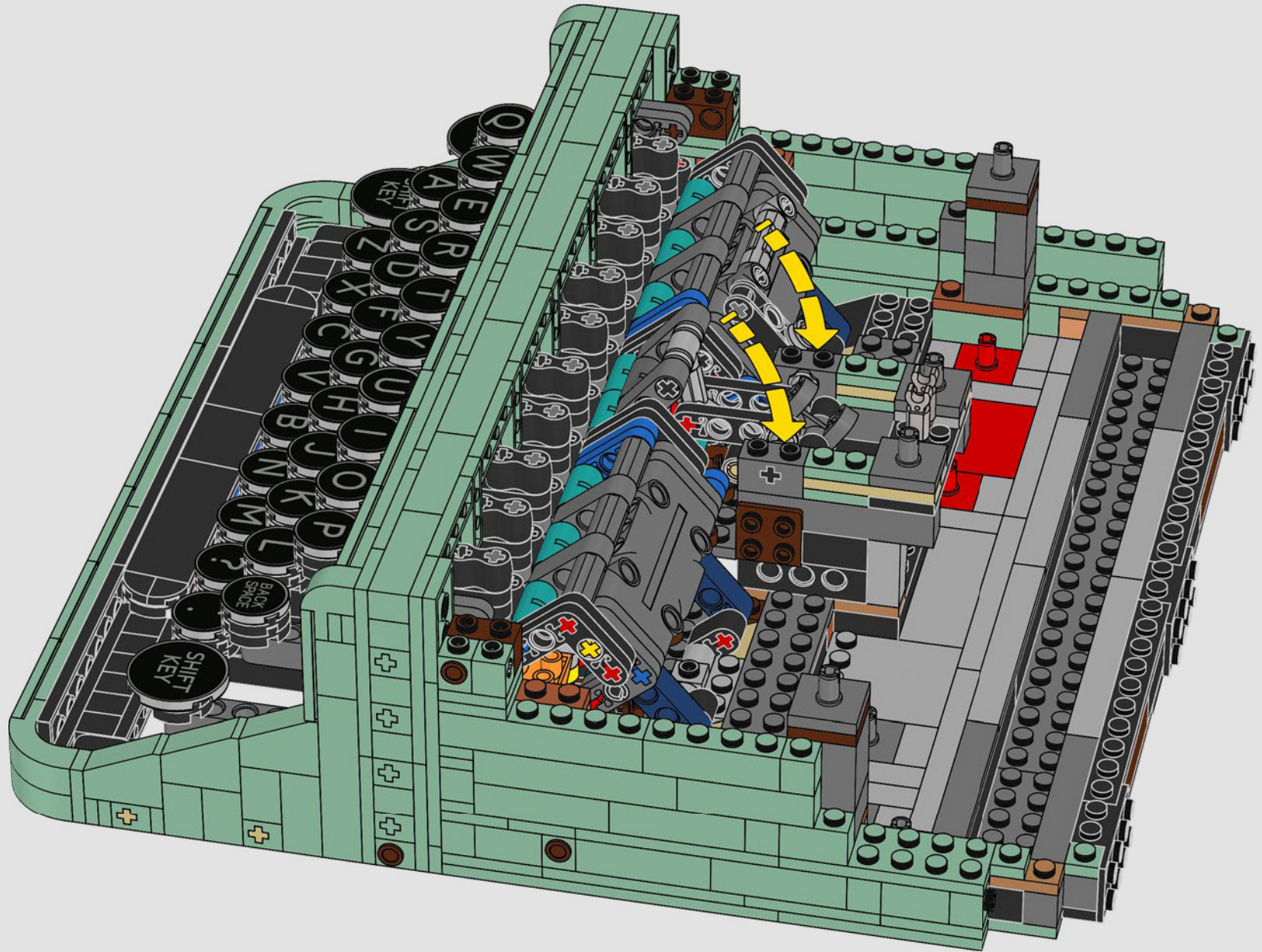

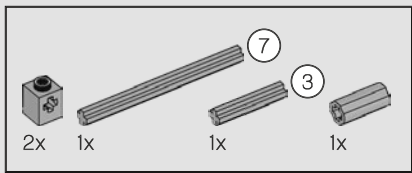

180

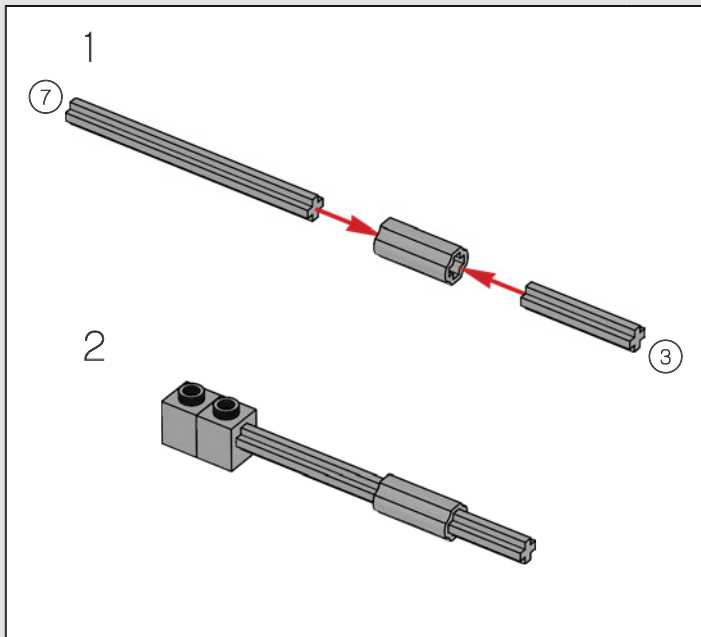
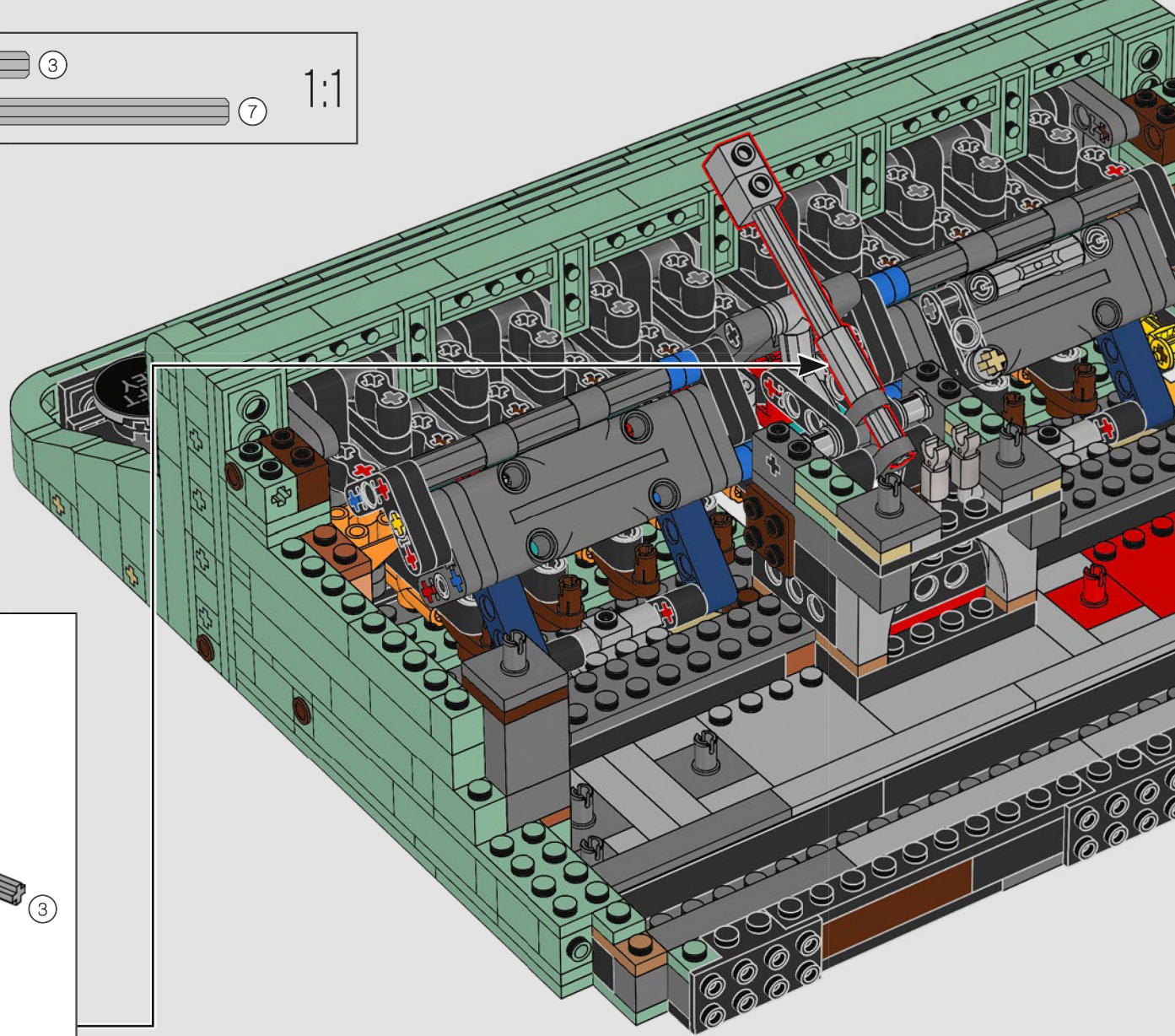



181

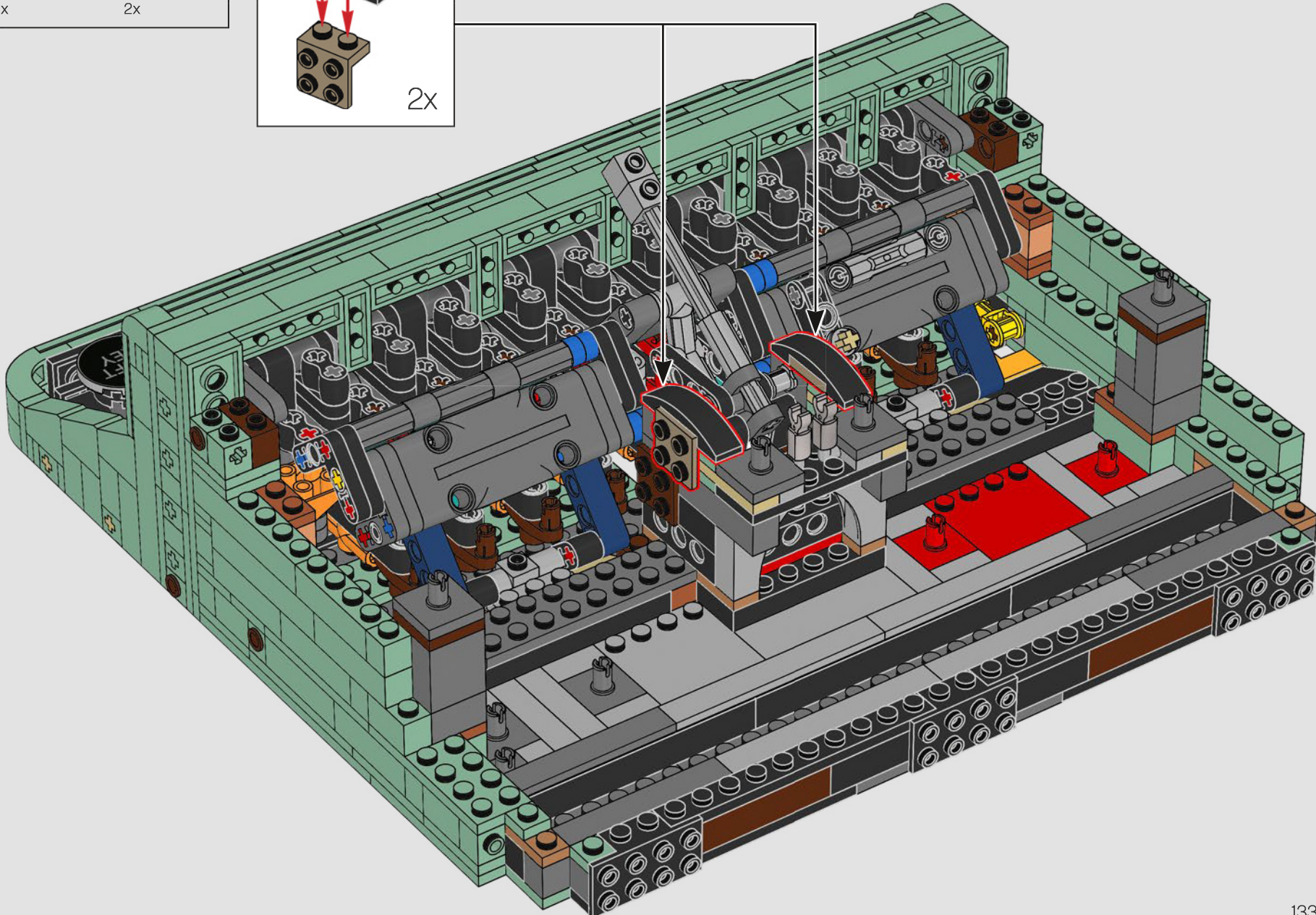
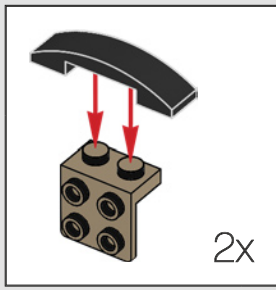

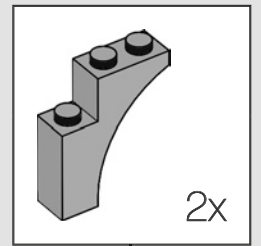
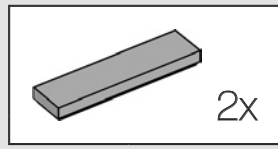
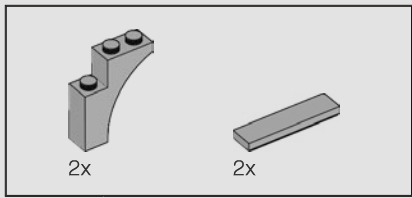

182

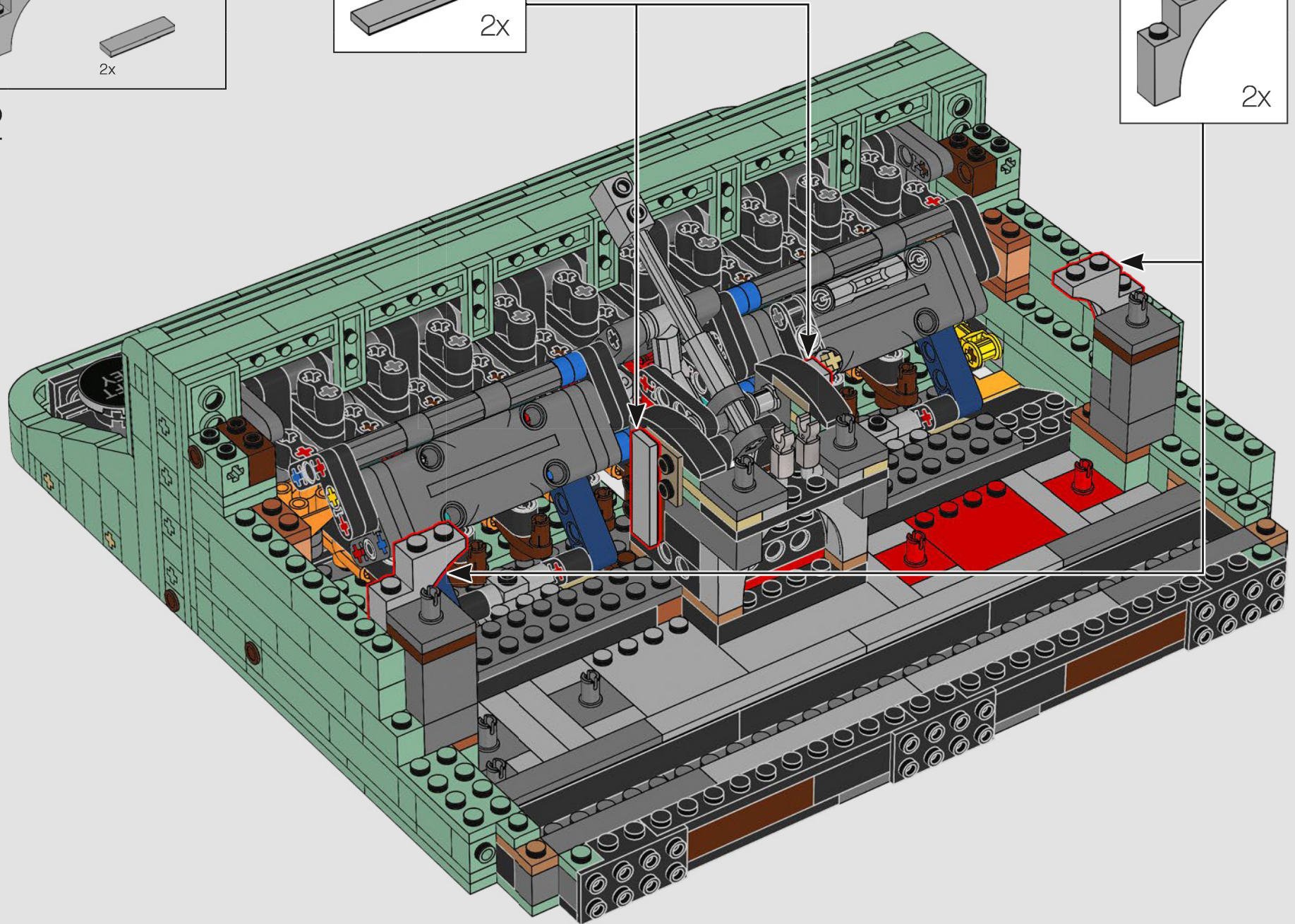

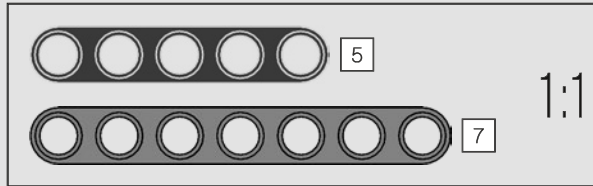
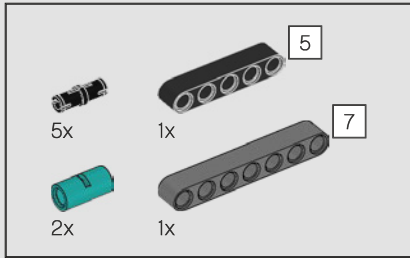
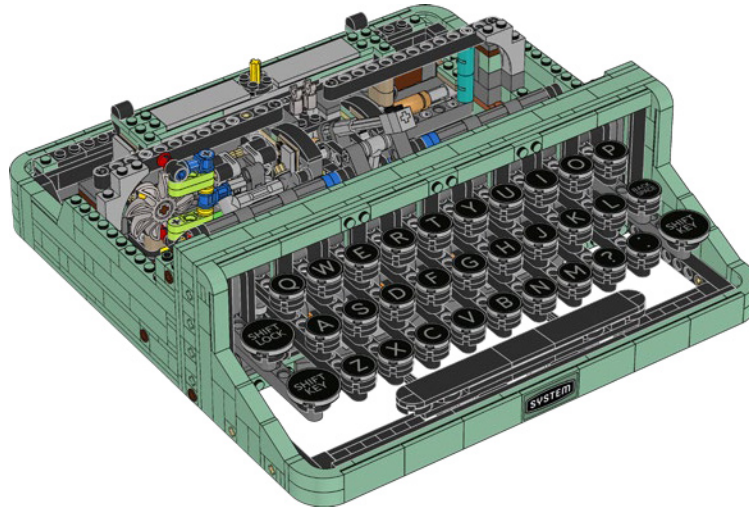

183

1

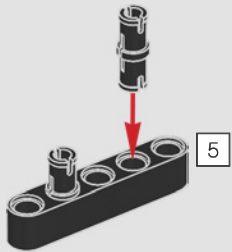

2

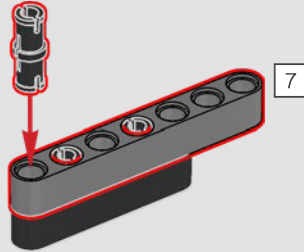

3

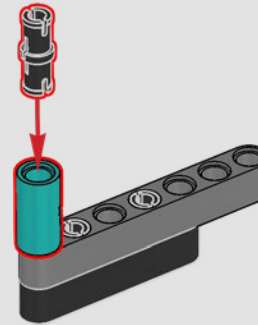

4

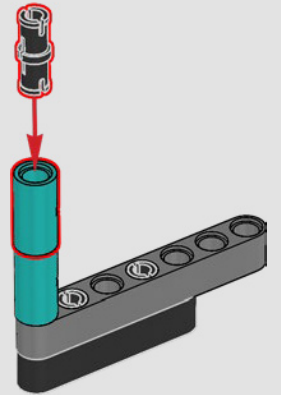

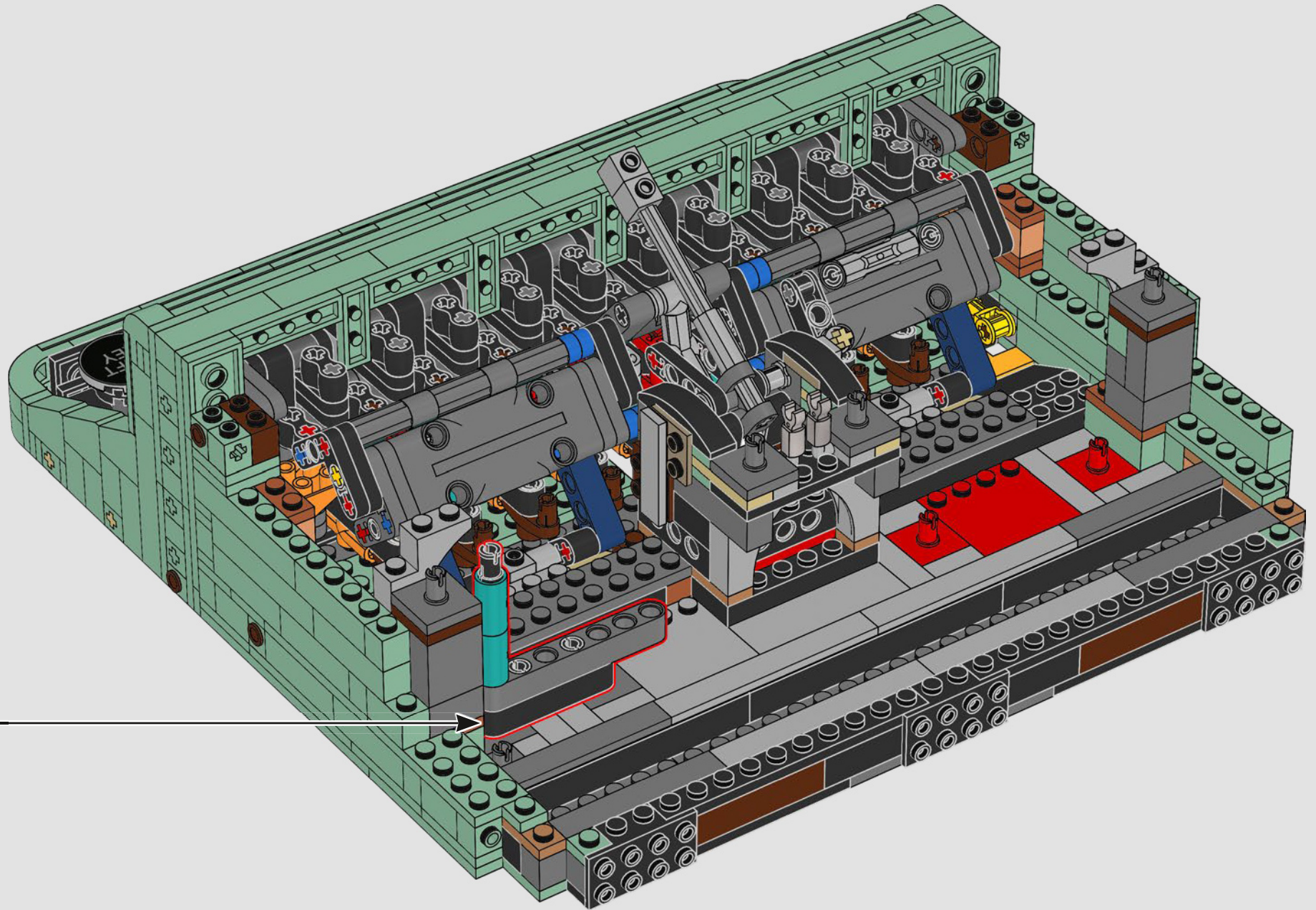

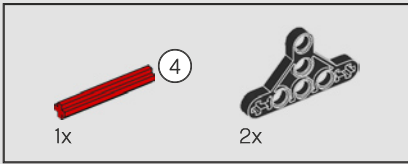
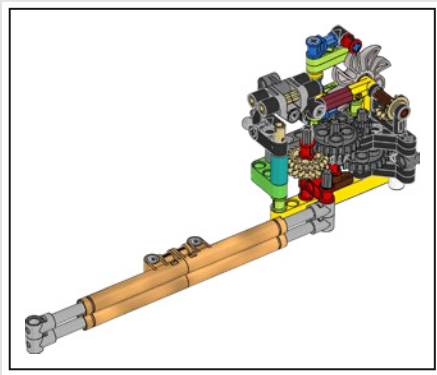

184

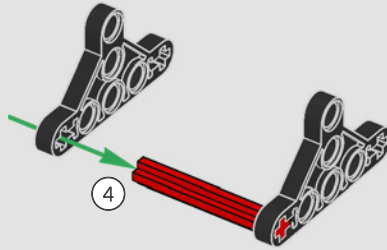

185

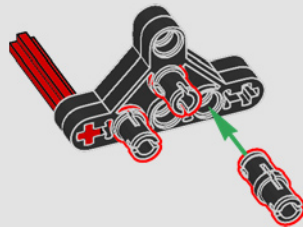

186

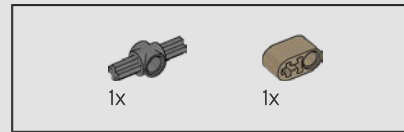
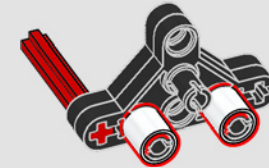

187

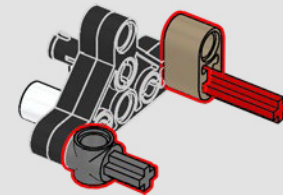

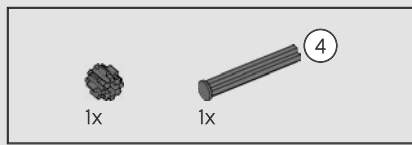

188

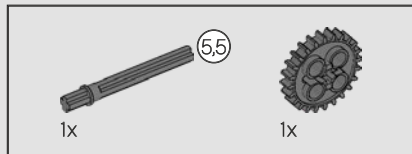
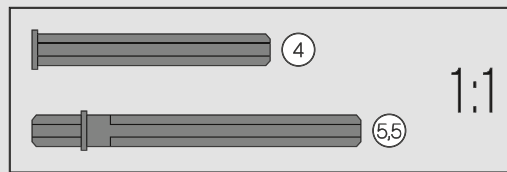
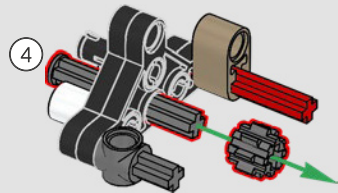

189

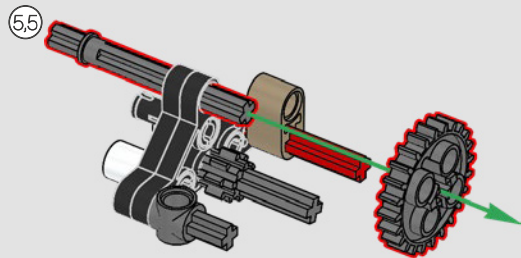

190

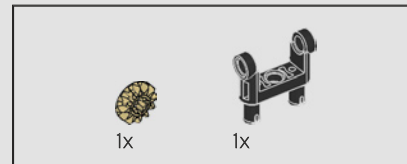
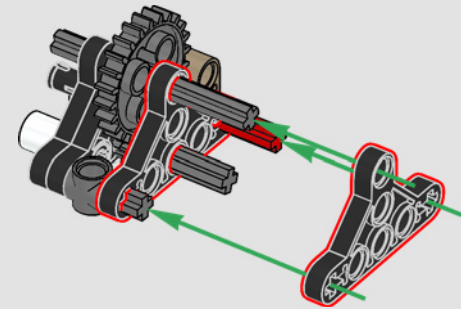

191

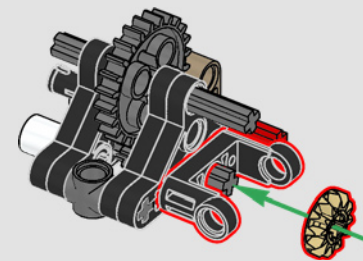

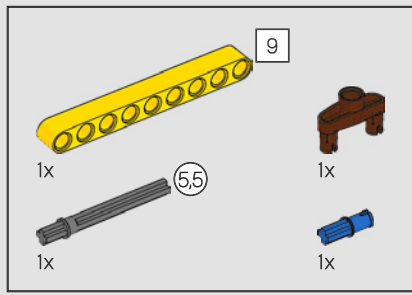

192

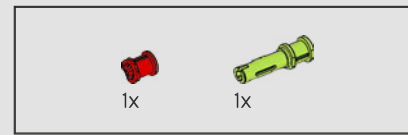
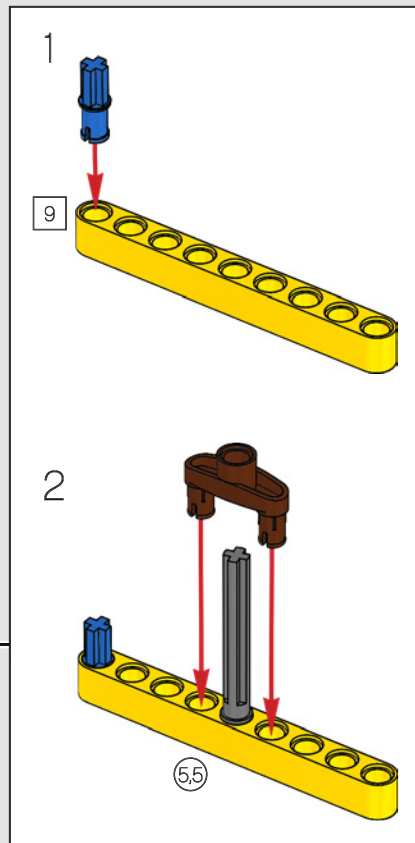
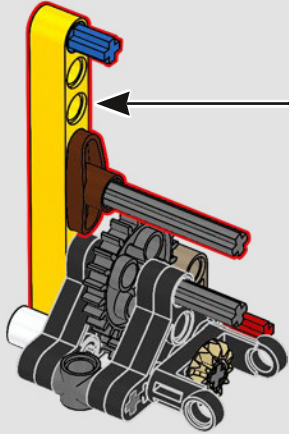

193

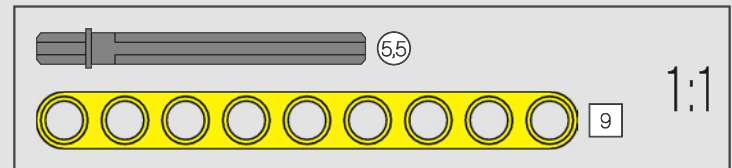
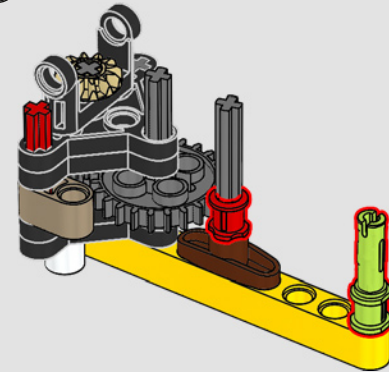

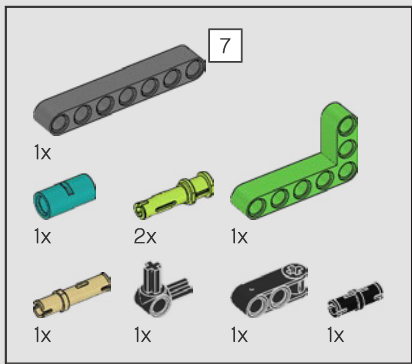

194

1

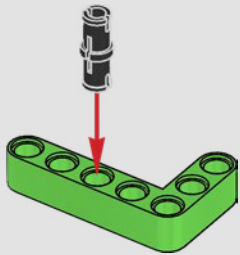

2

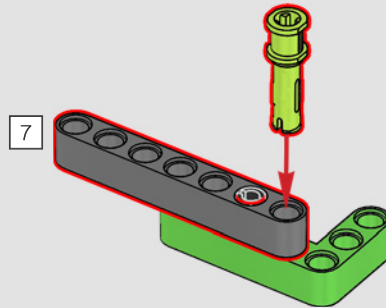

3

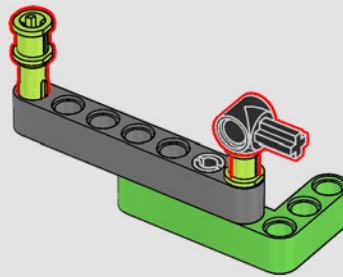

4

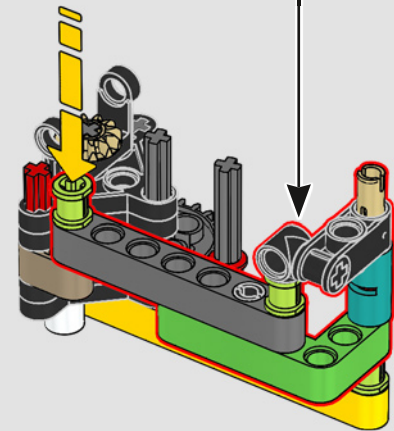
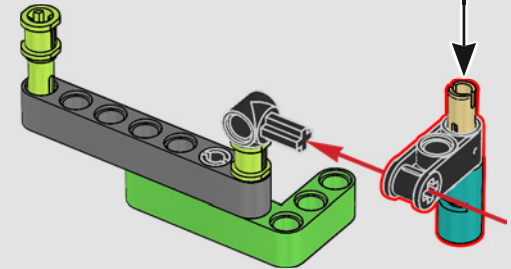

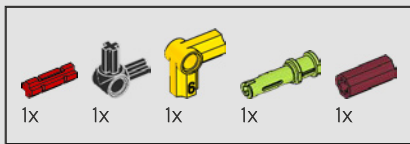

195

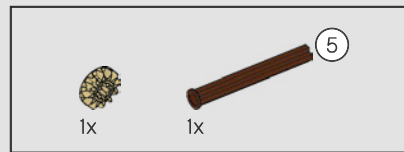
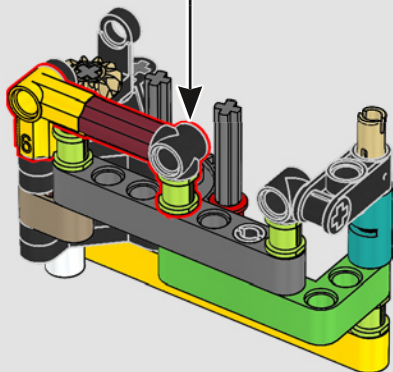
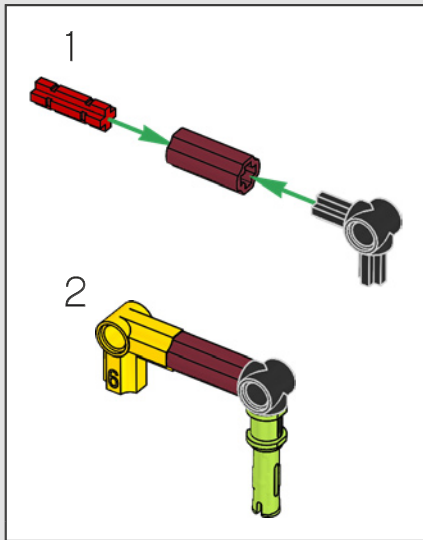

196

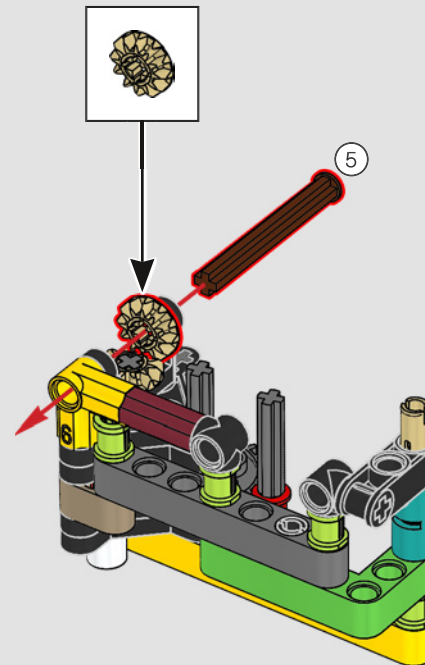
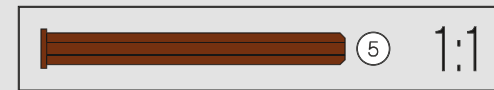



197

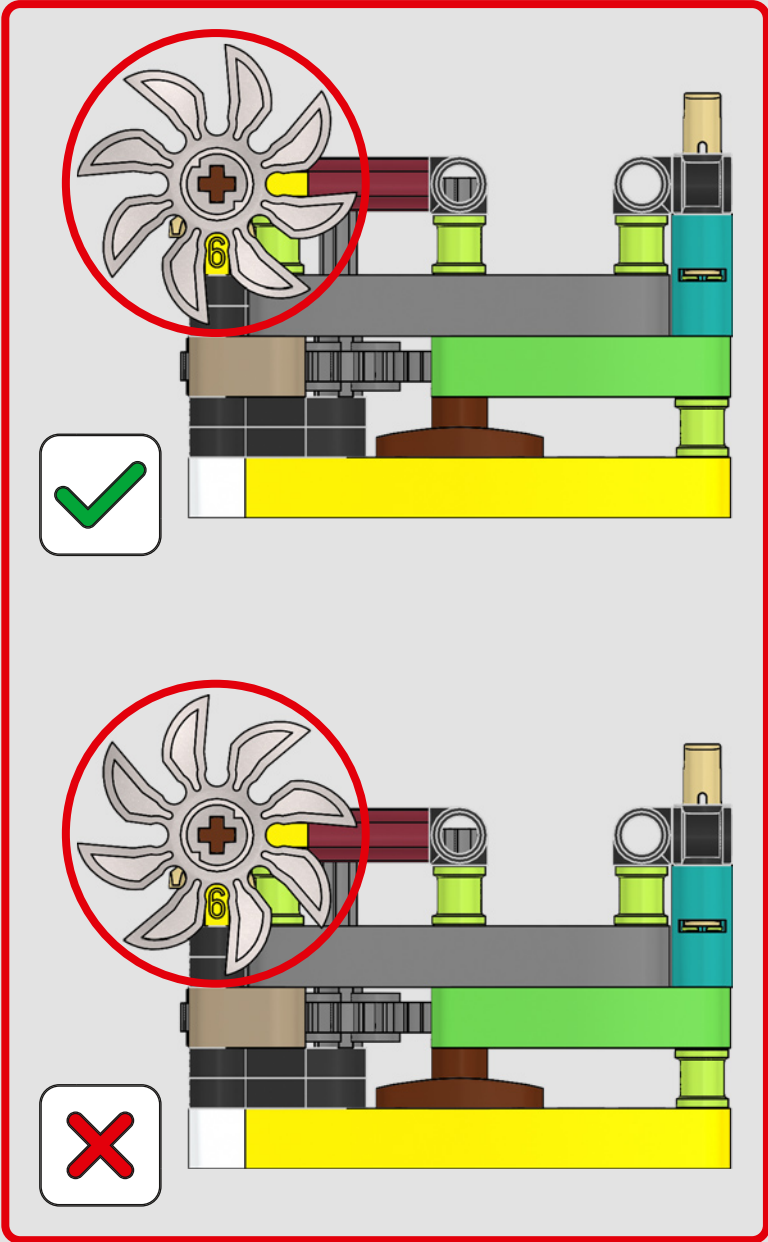
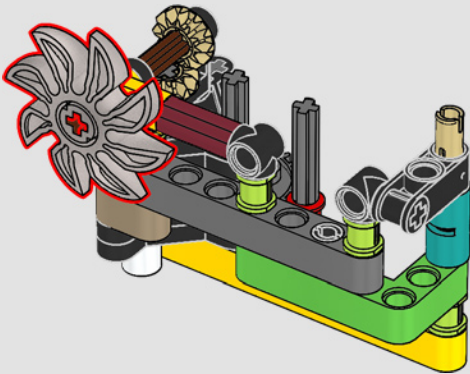

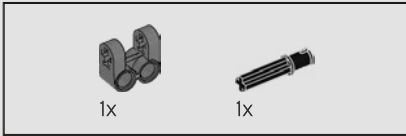
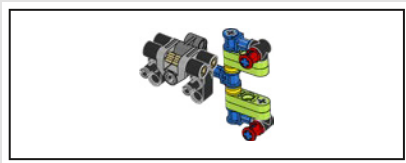

198

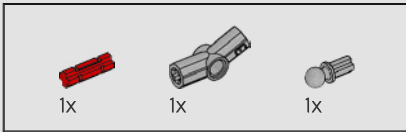
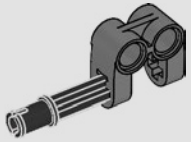

199

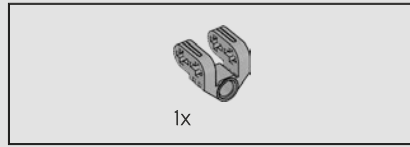
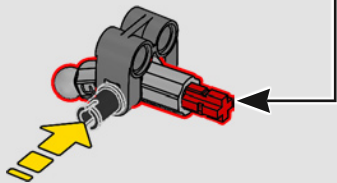
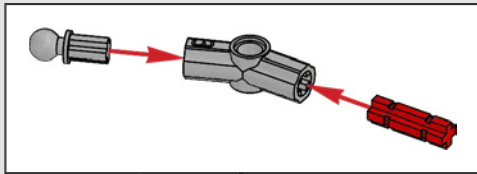

200

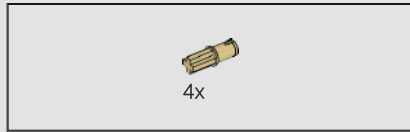
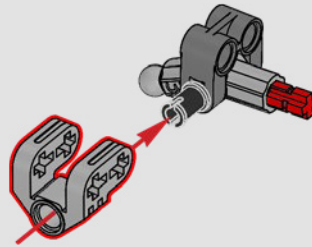

201

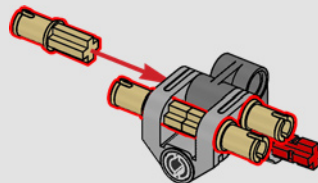

202

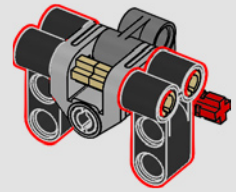

203

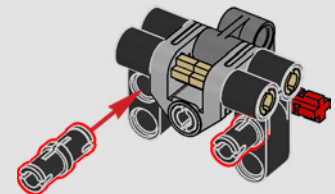

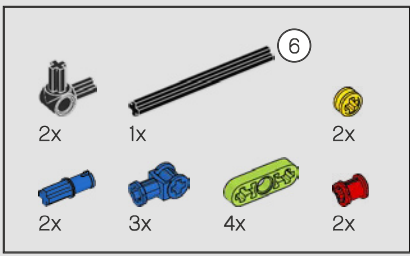

204

1

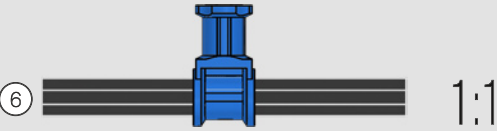

2

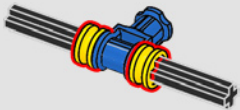

3

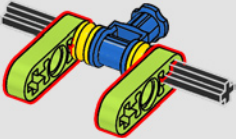

4

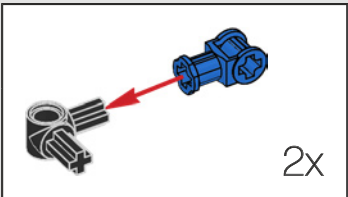
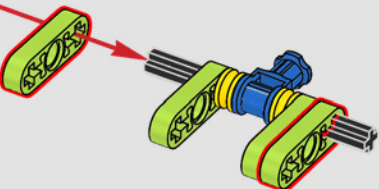

5

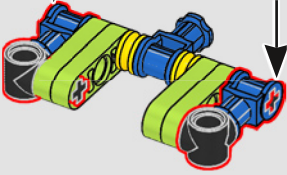

6

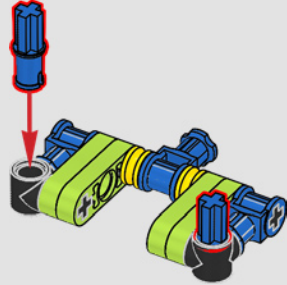

7

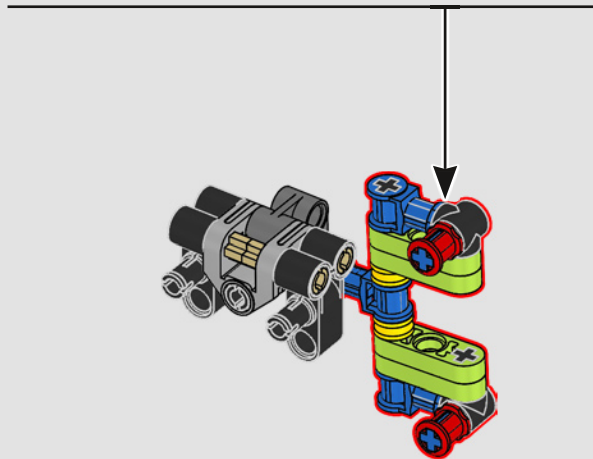
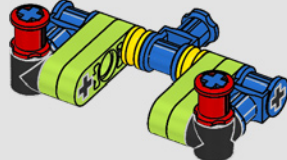

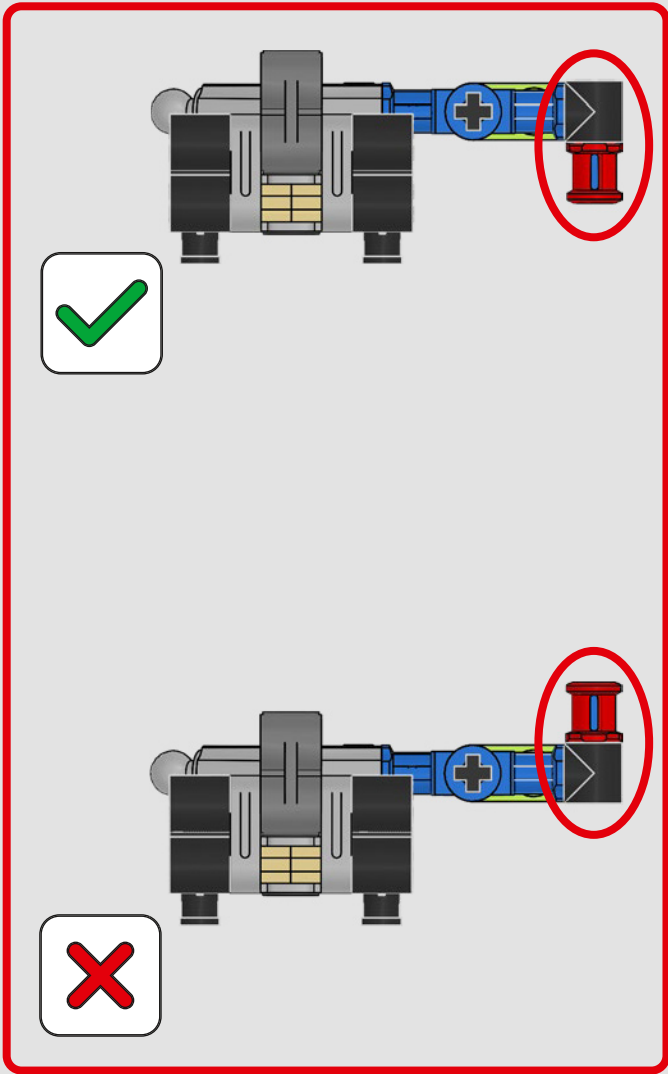

205

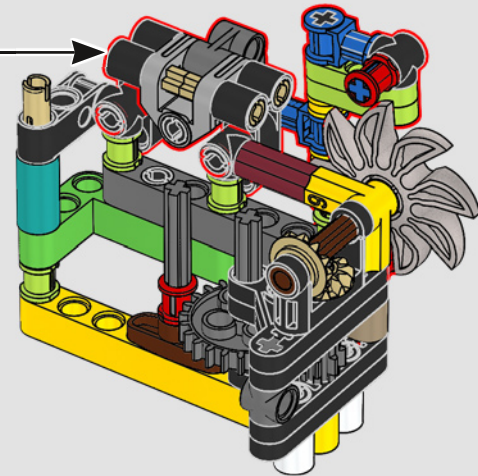



1x

206

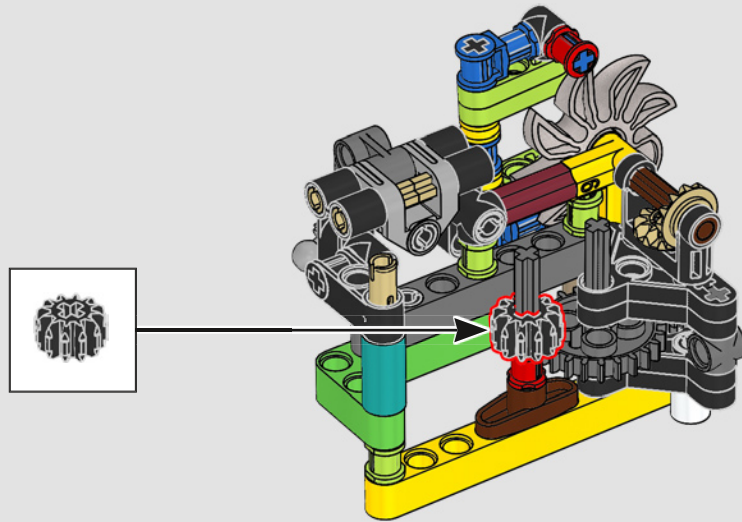

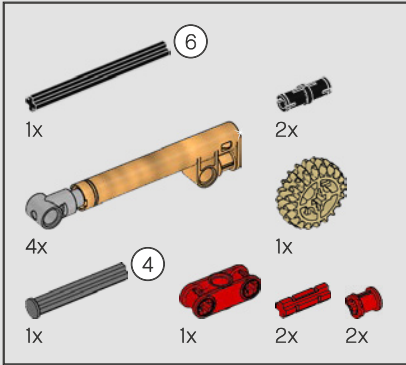
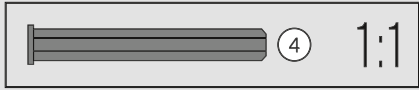
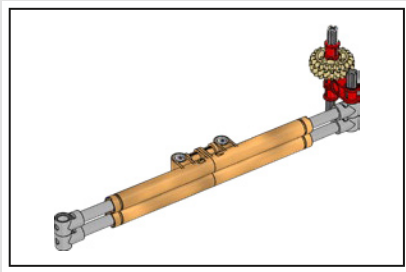

207

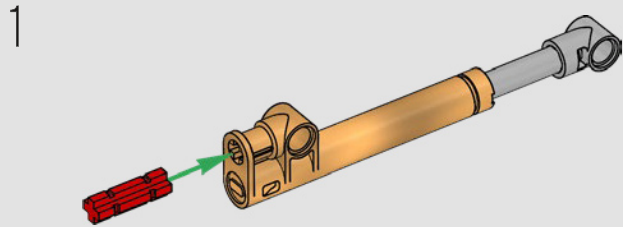

2

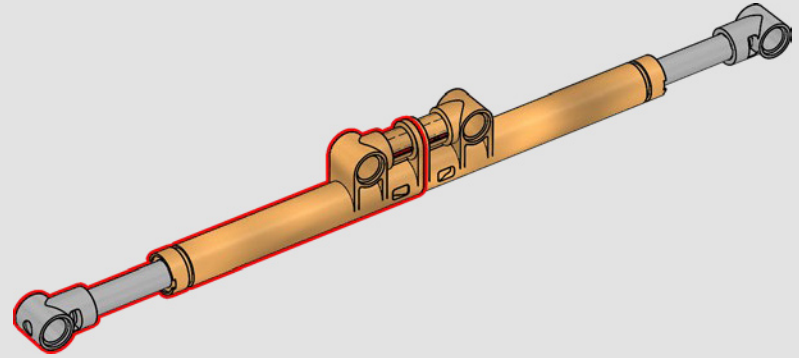

3

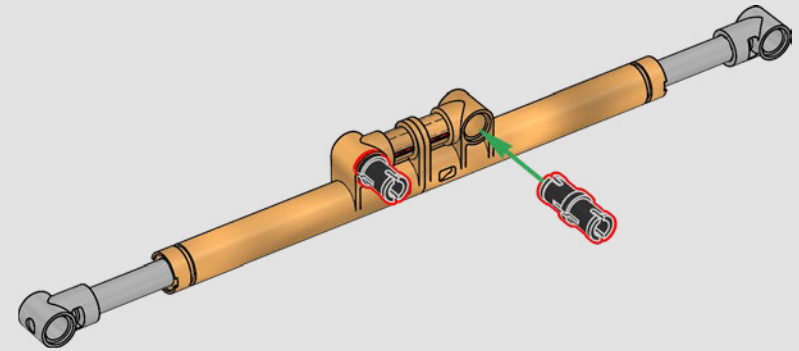

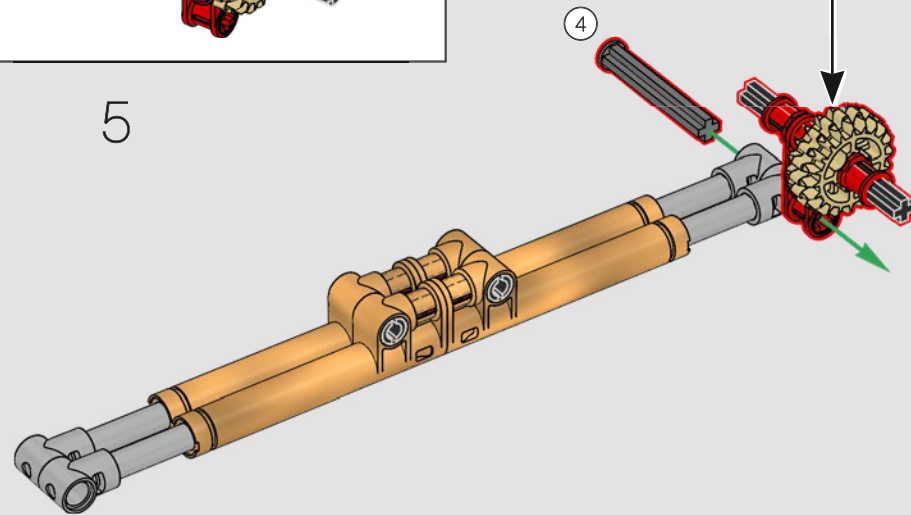
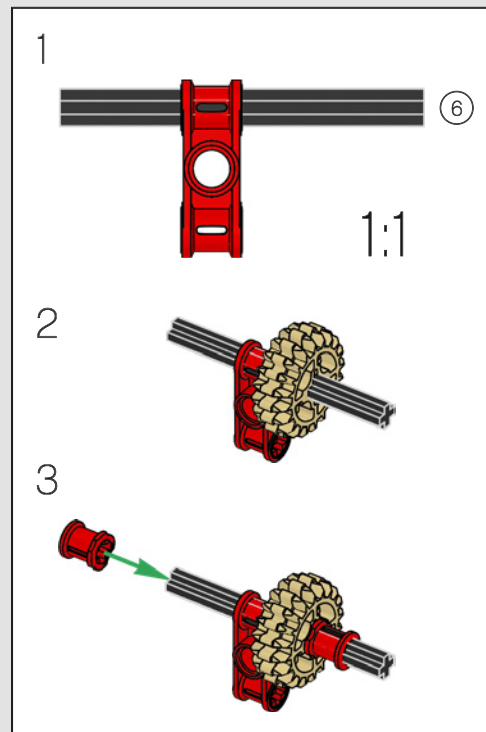
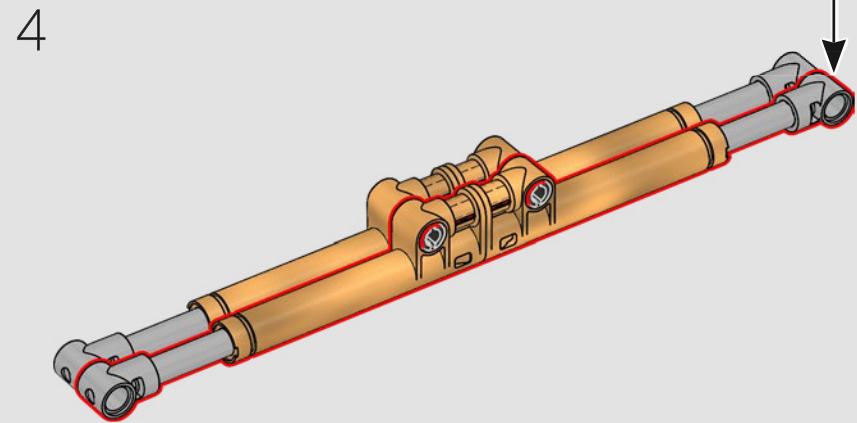
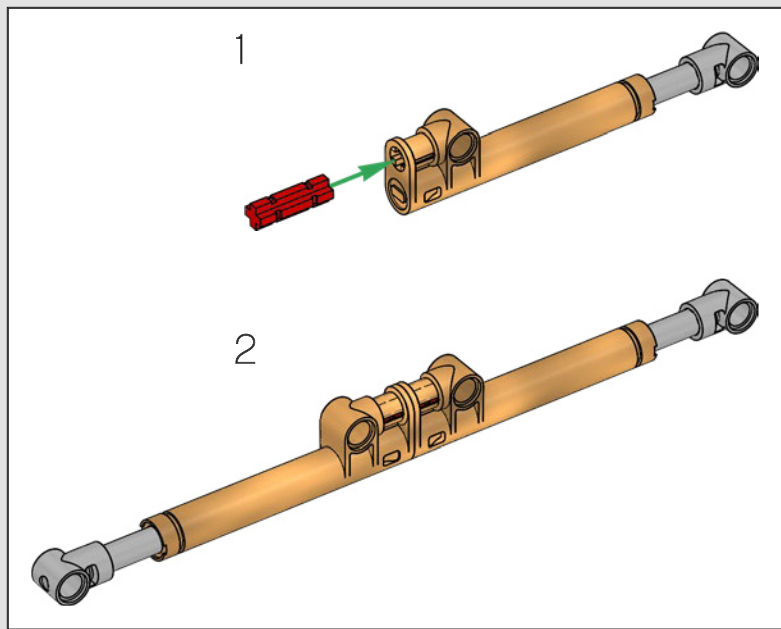



208

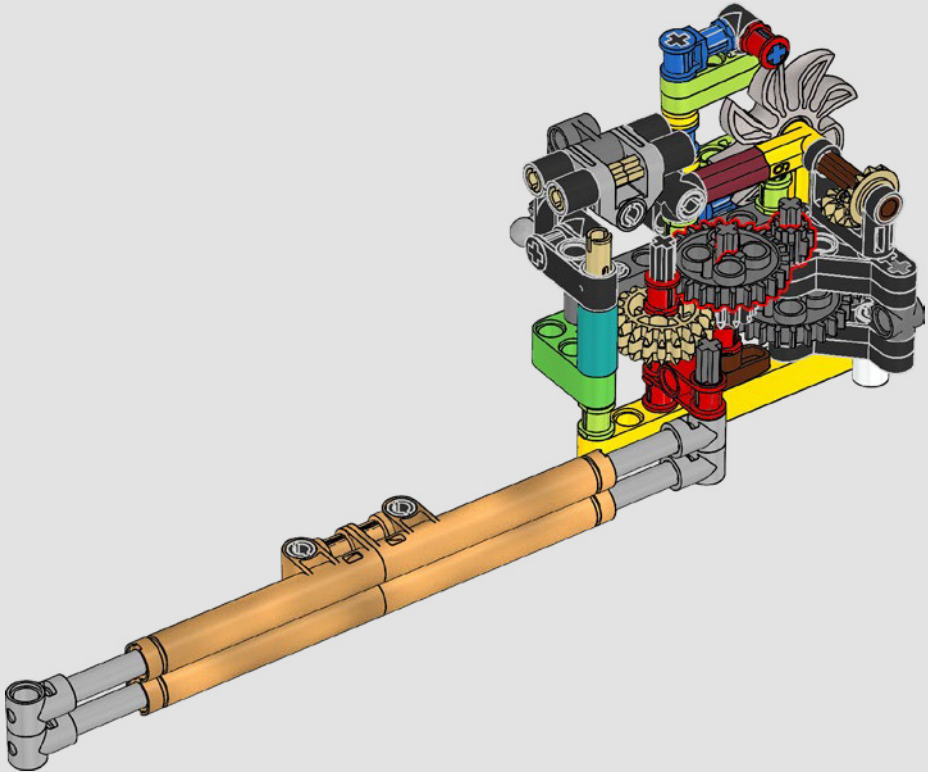
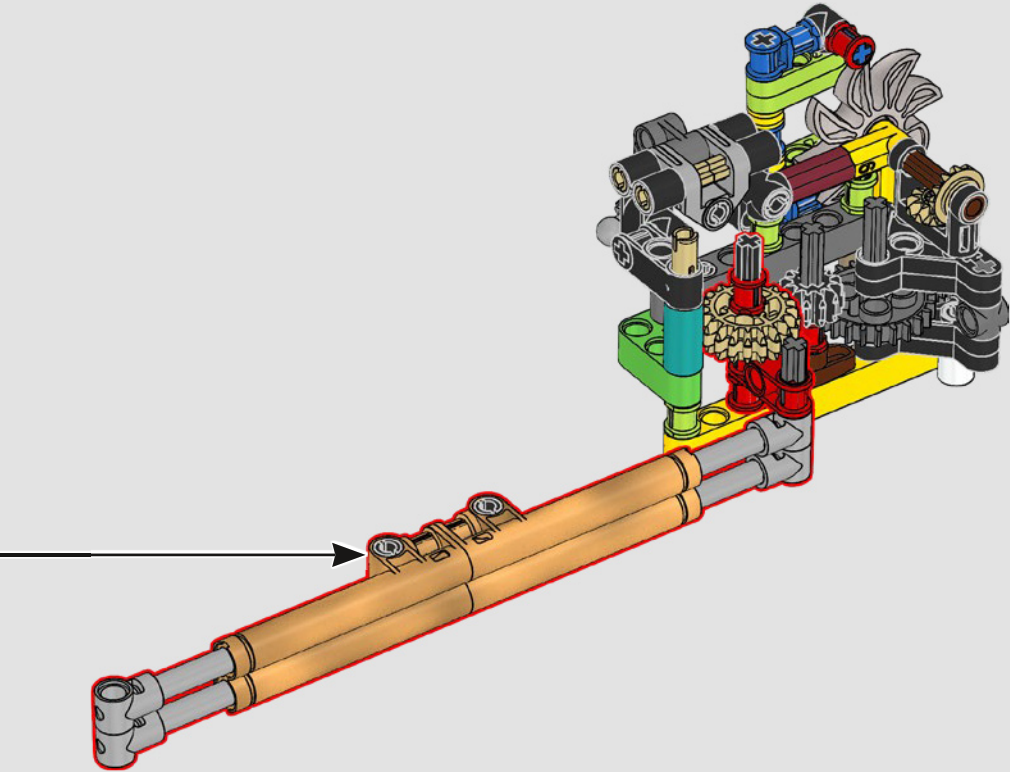

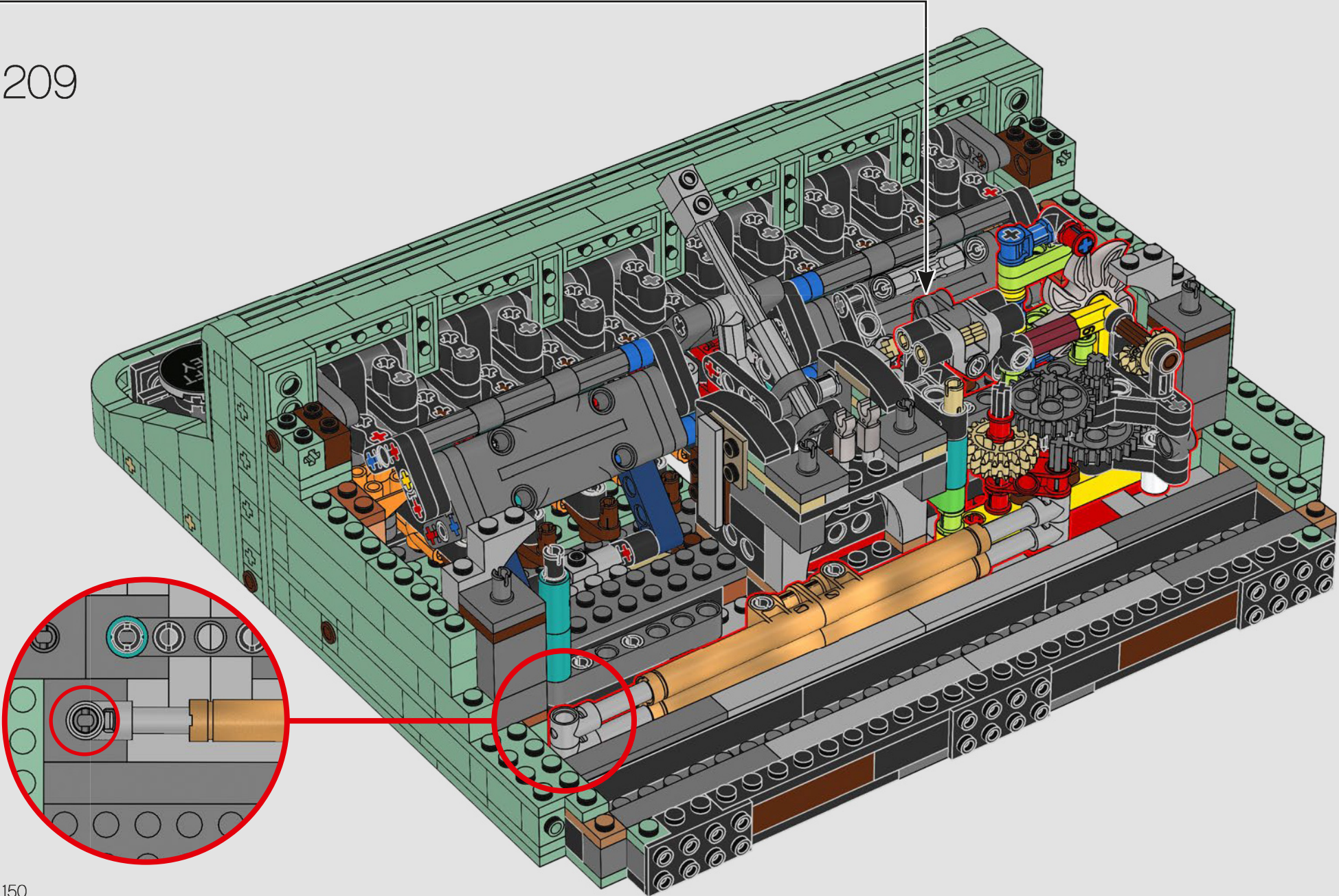

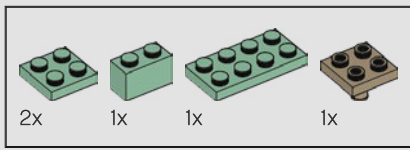

210

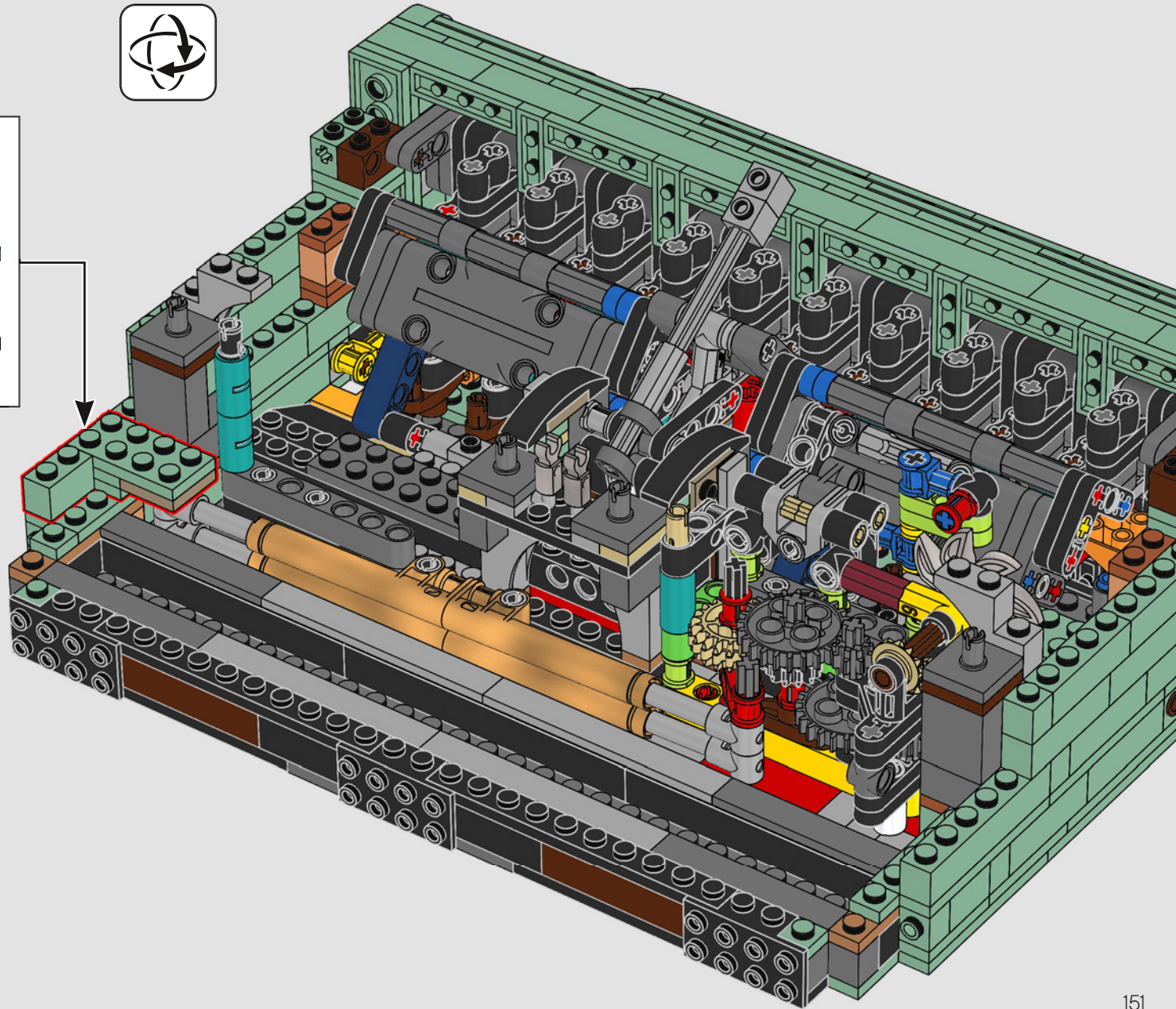
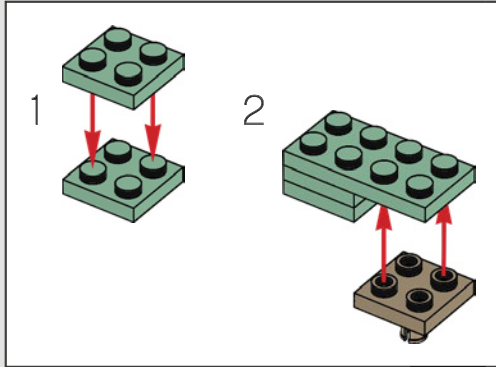

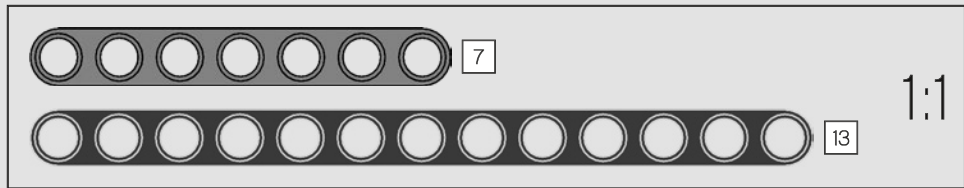
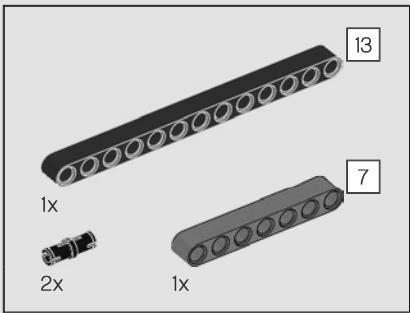

211

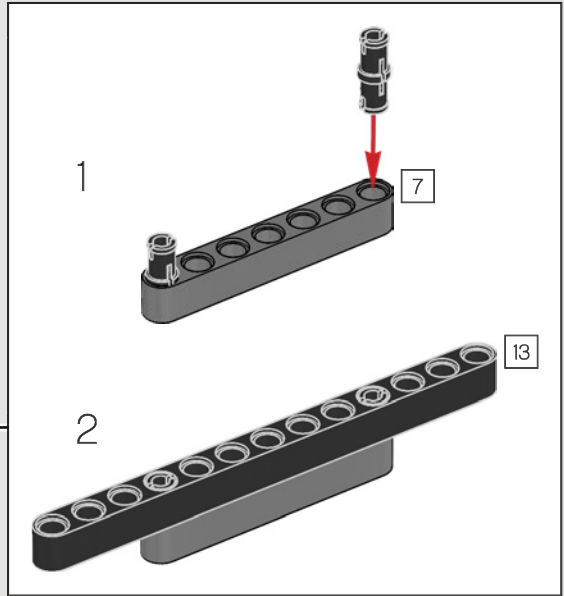
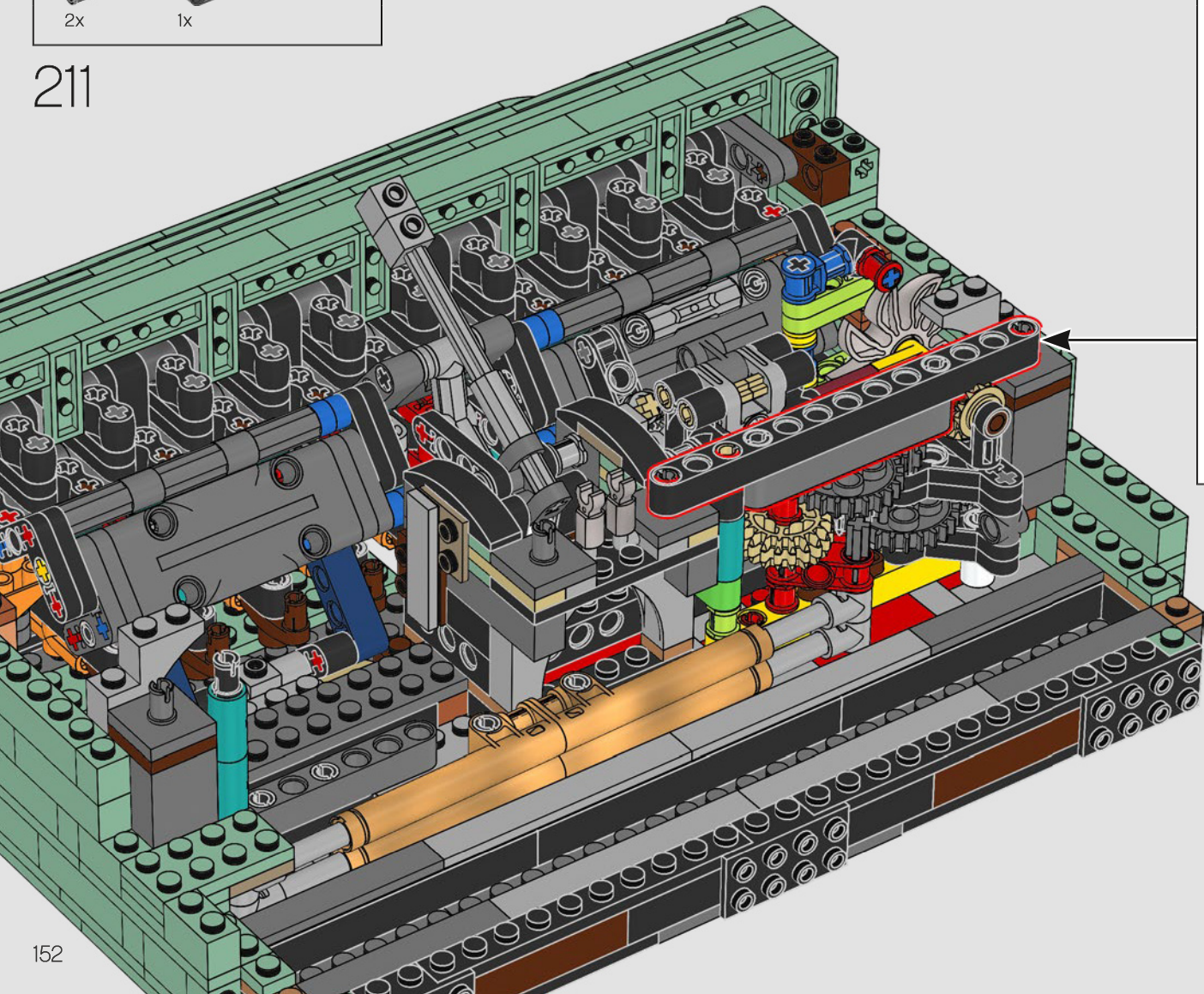

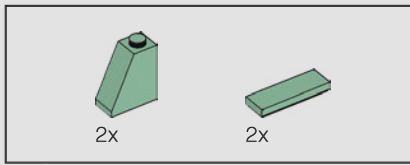

212

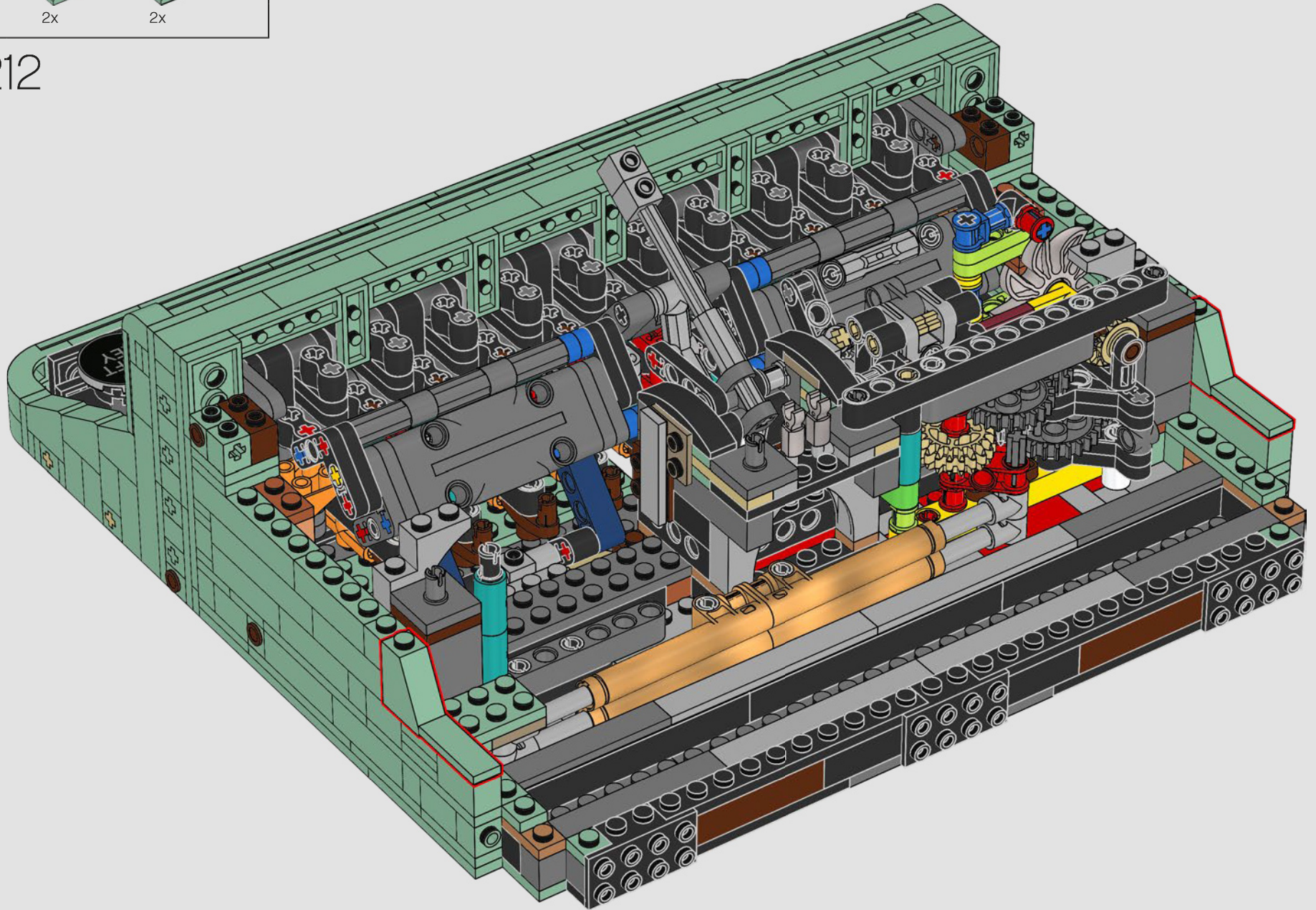

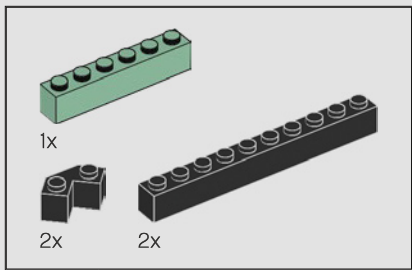

213

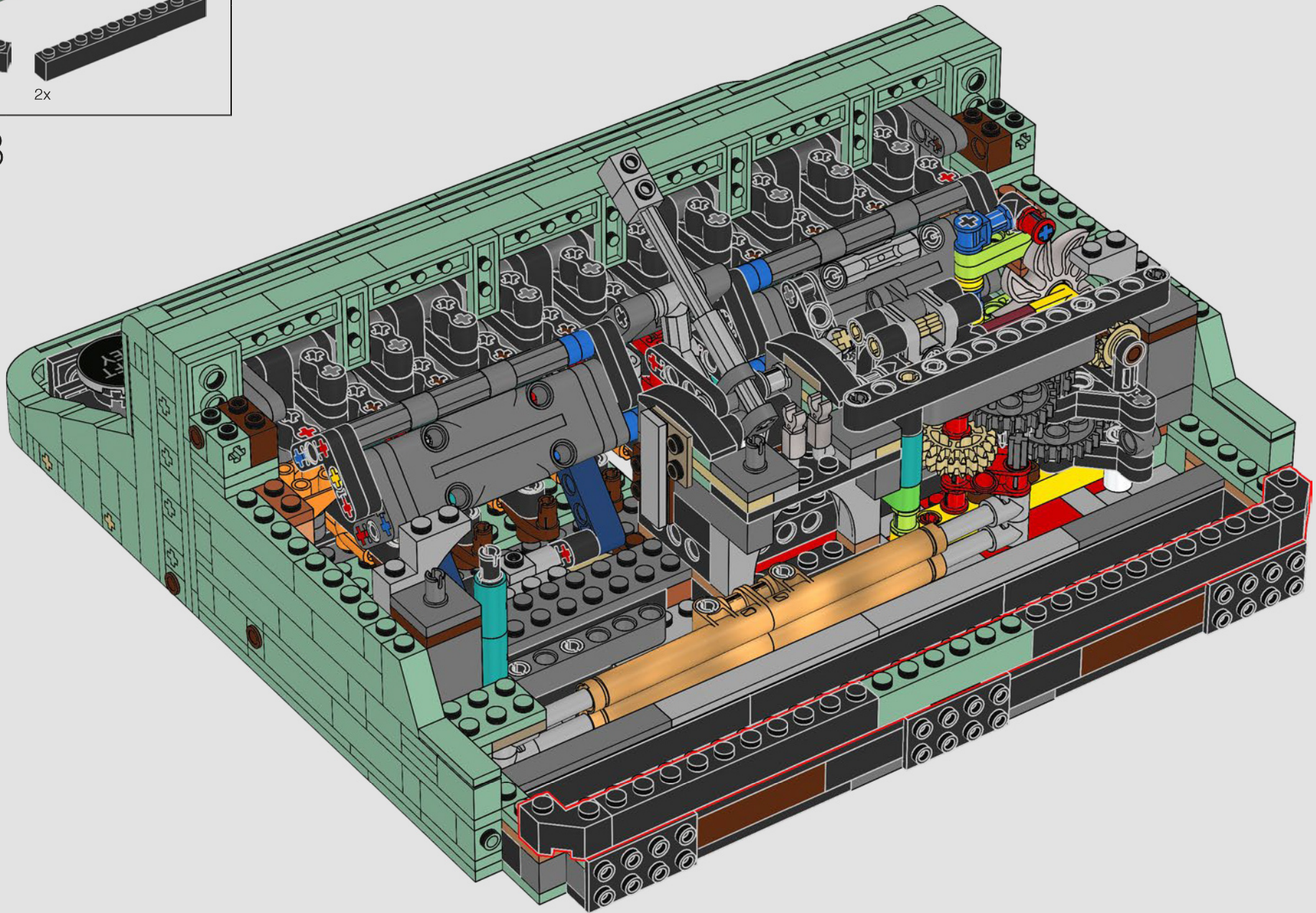

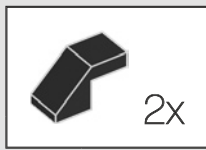
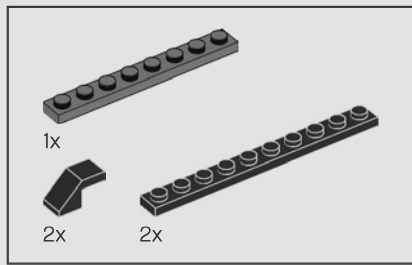

214

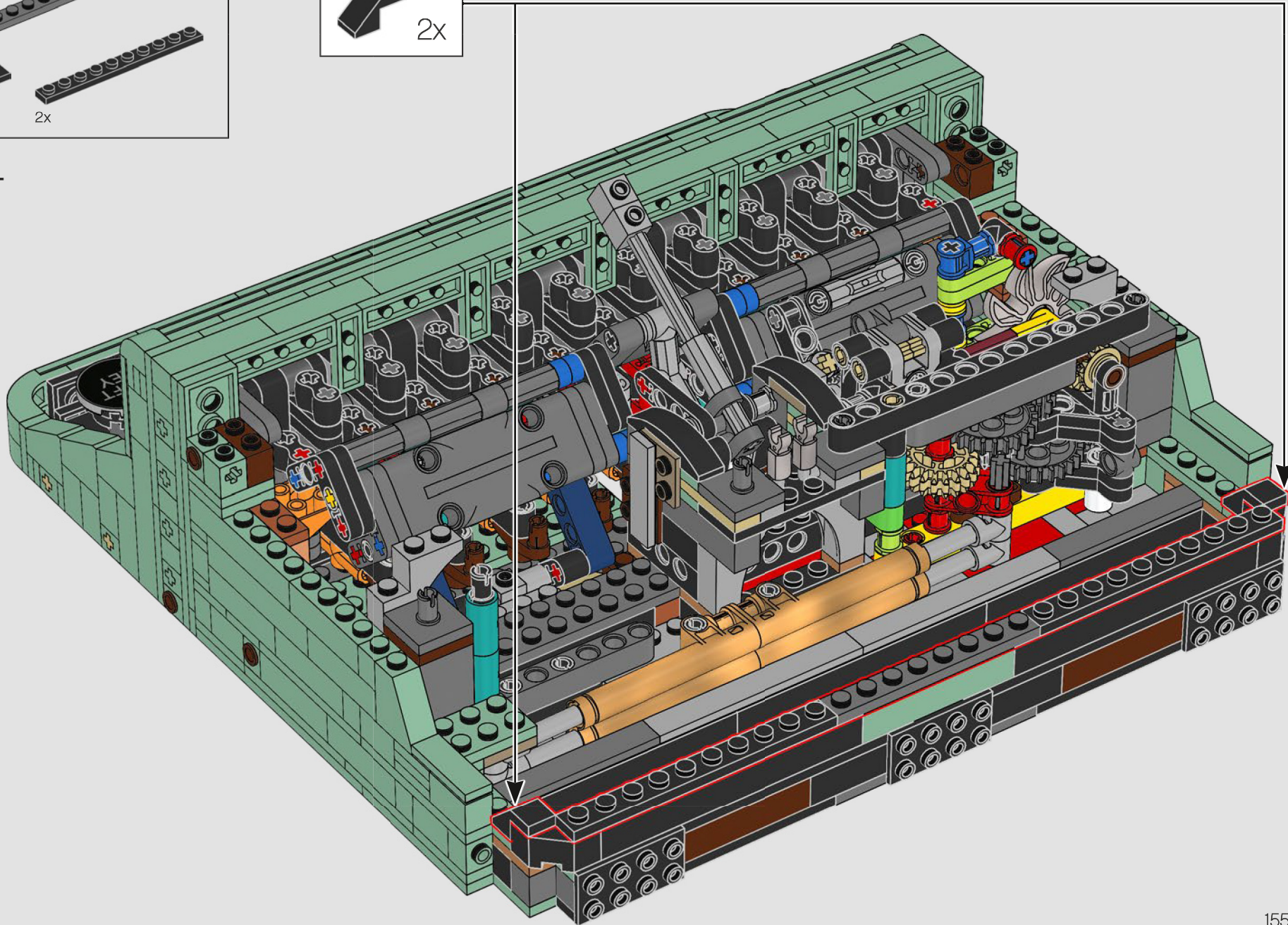

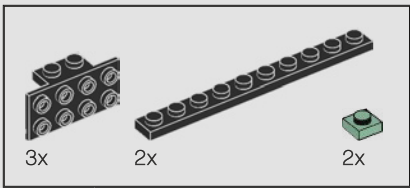

215

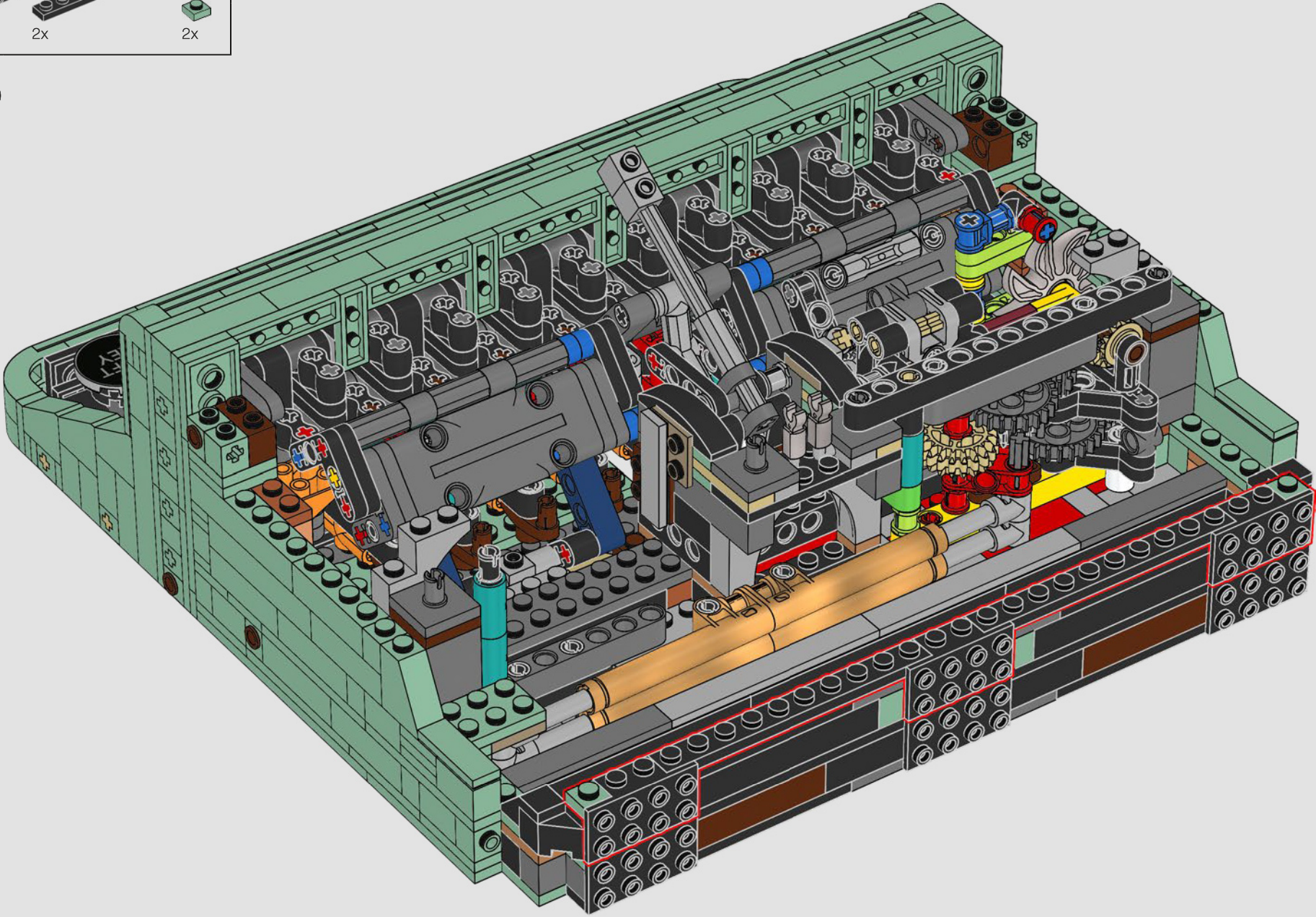

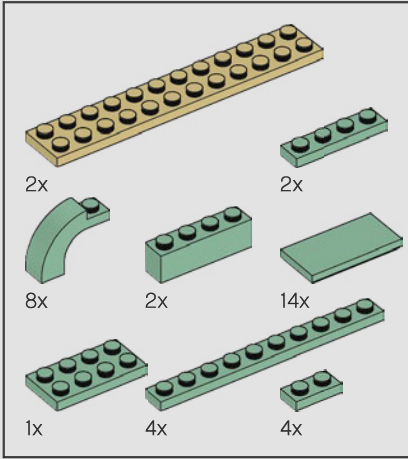
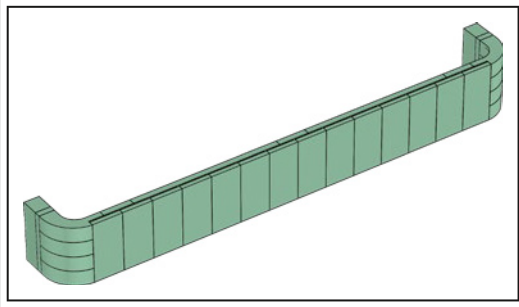

216

1

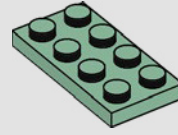

2

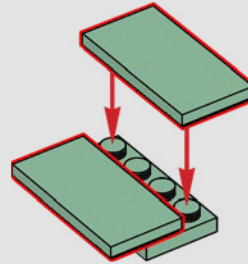

3

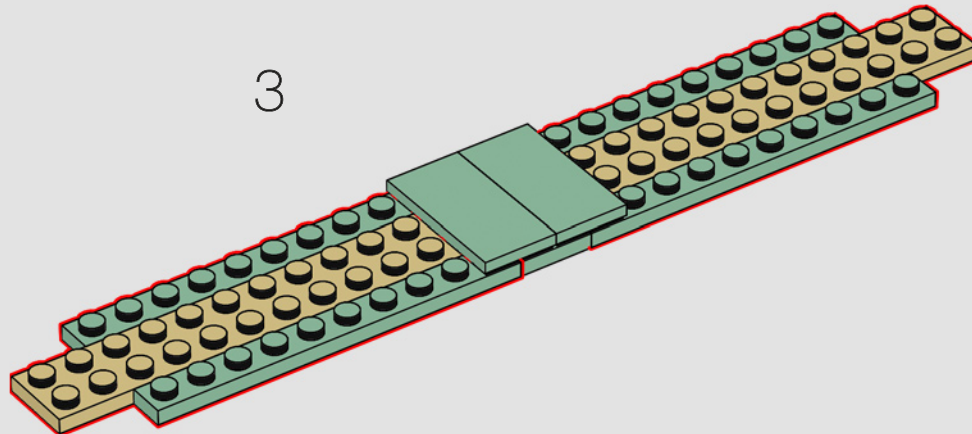

4

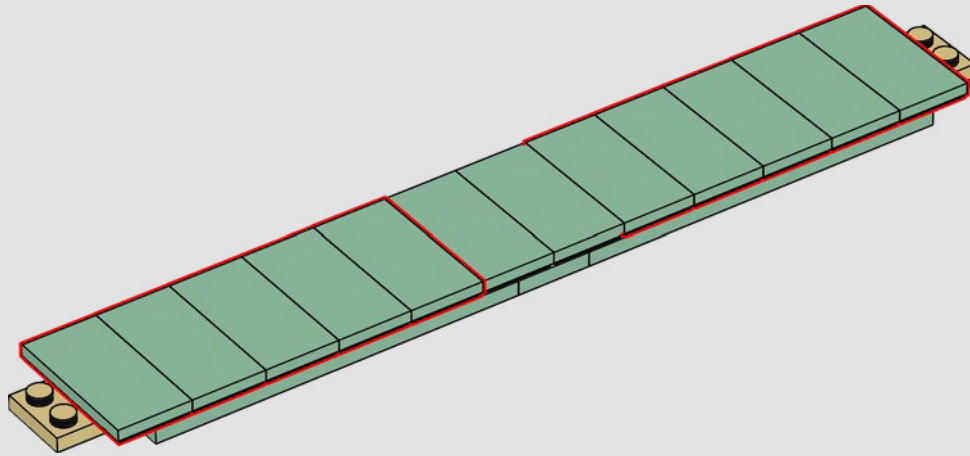

5

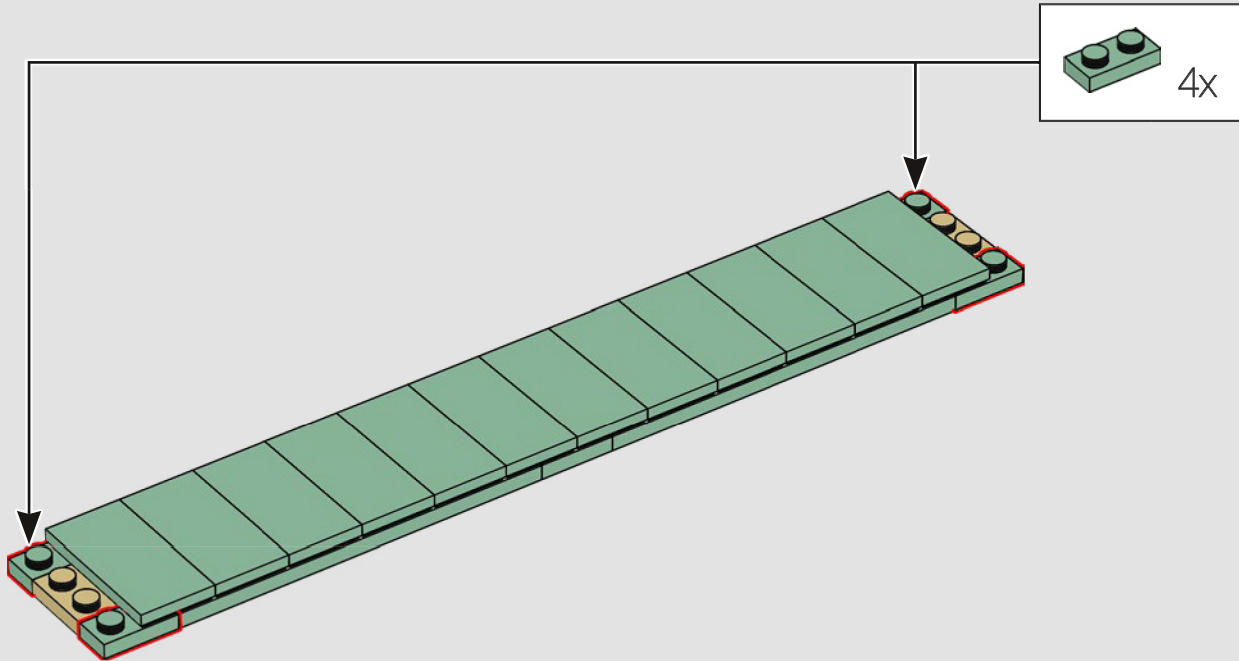

6

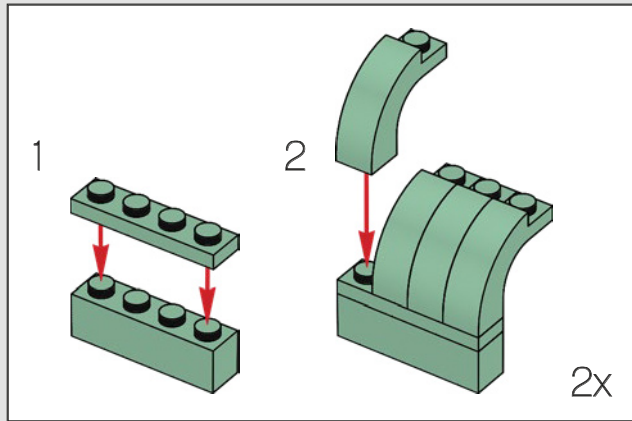
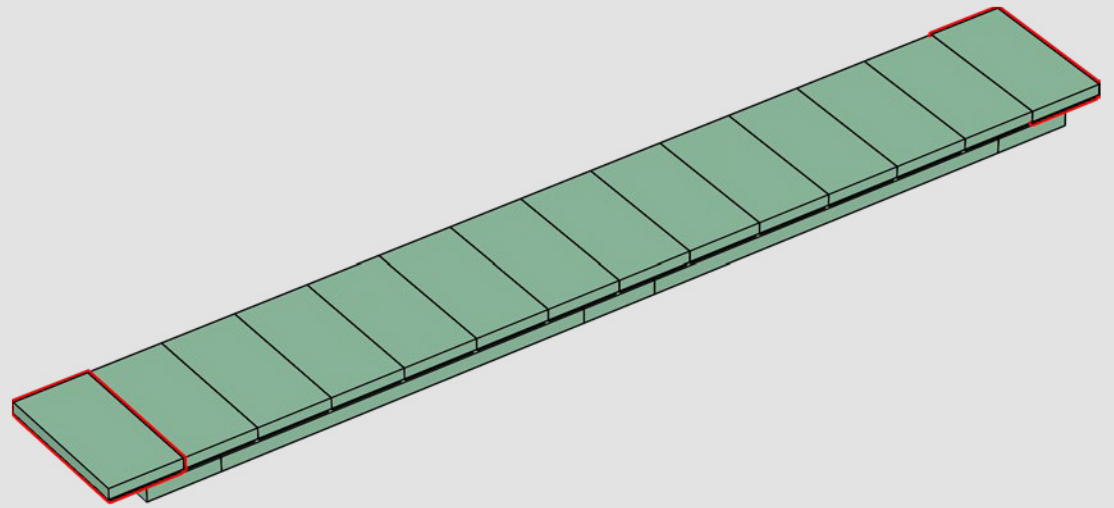

7

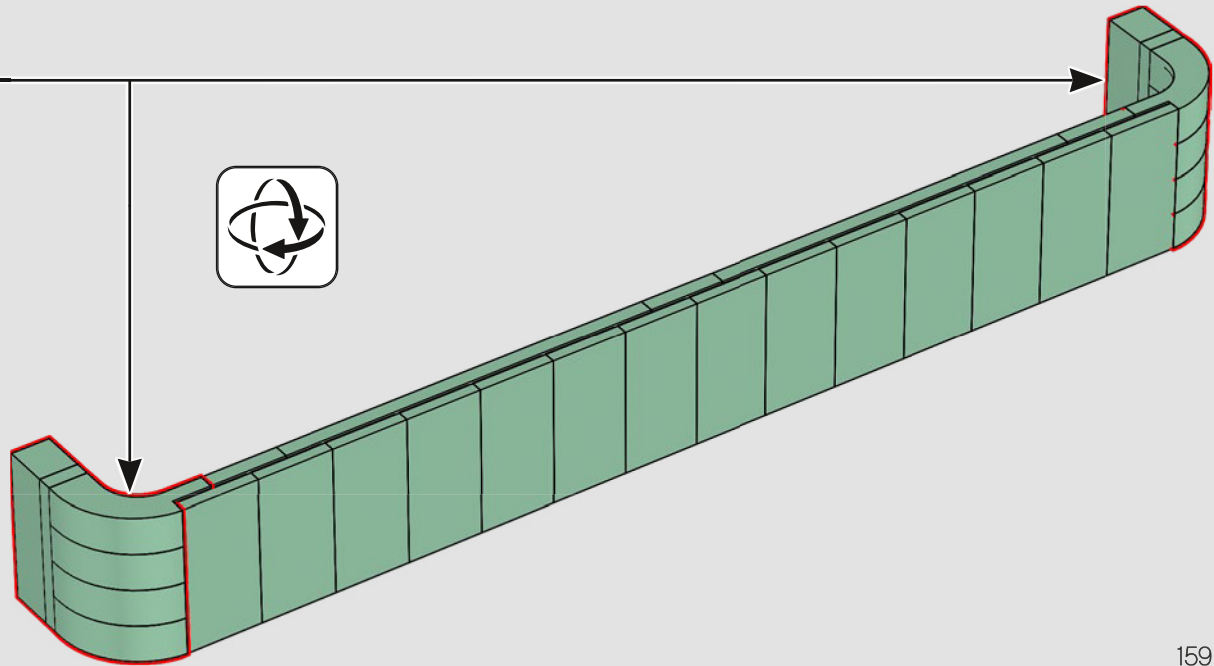

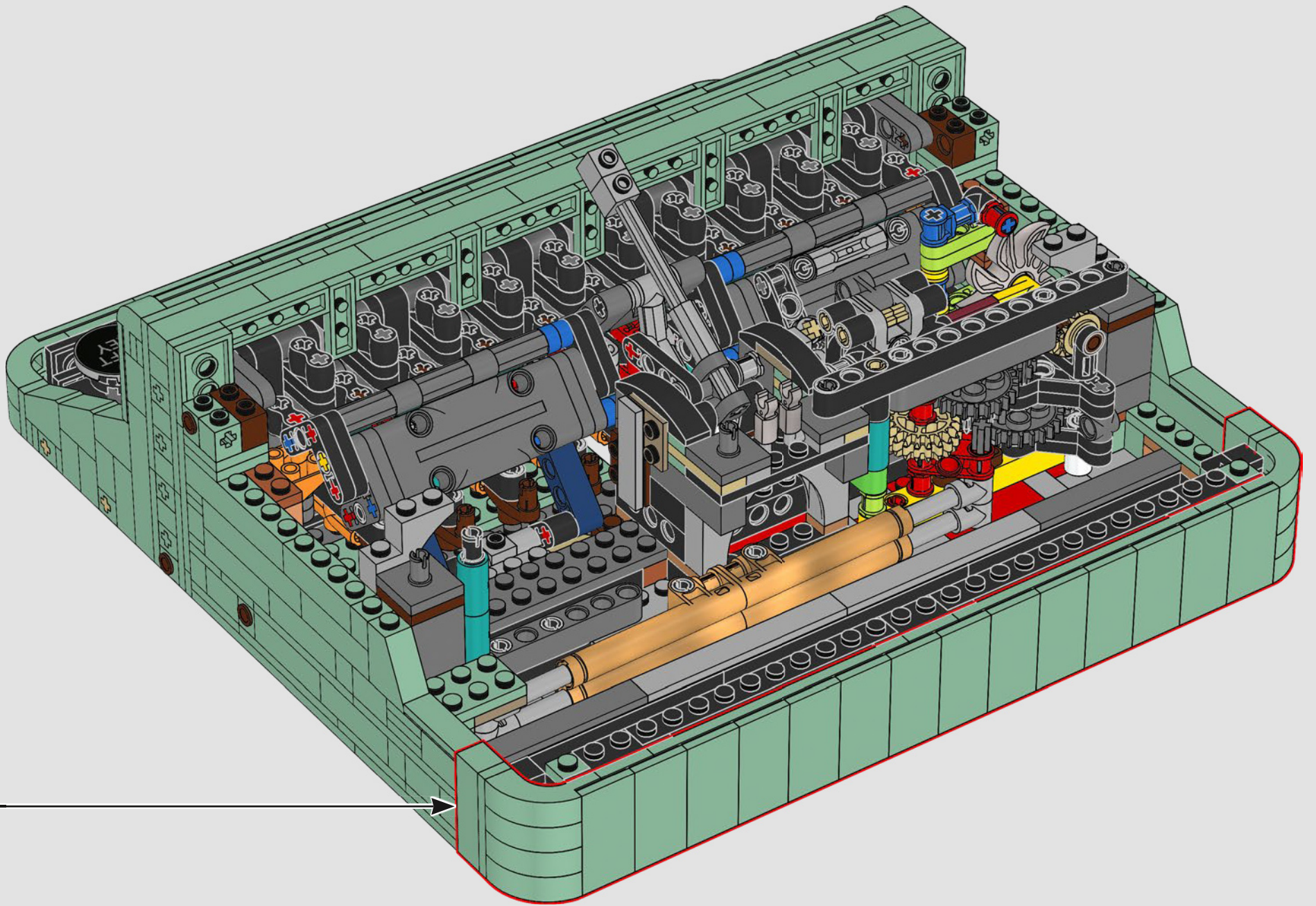

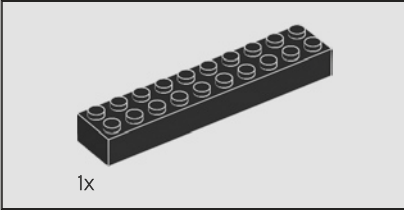
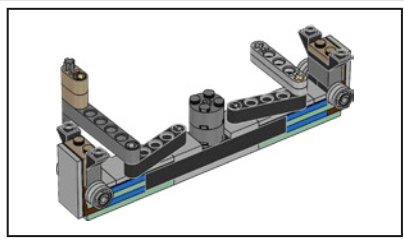

217

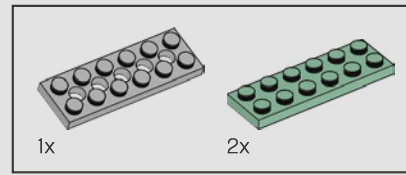
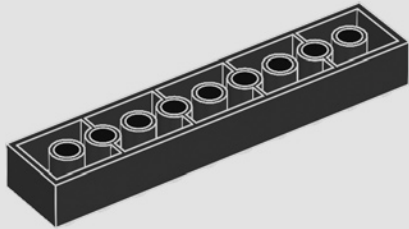

218

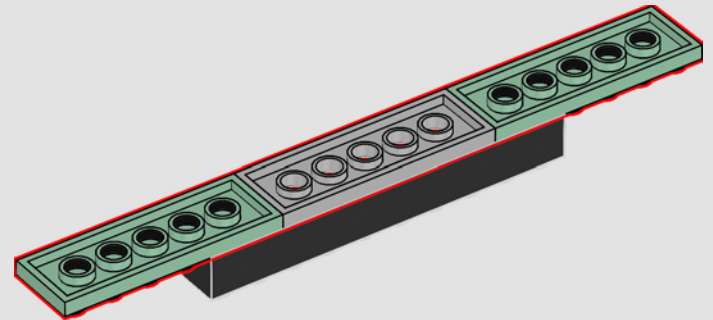

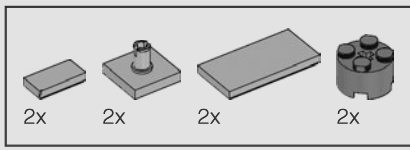

220

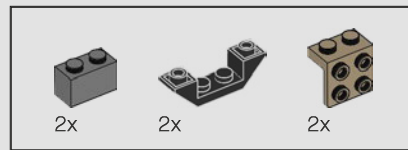
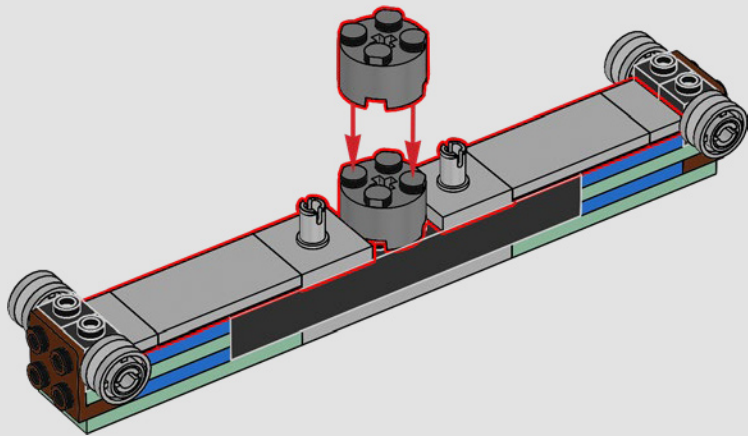

221

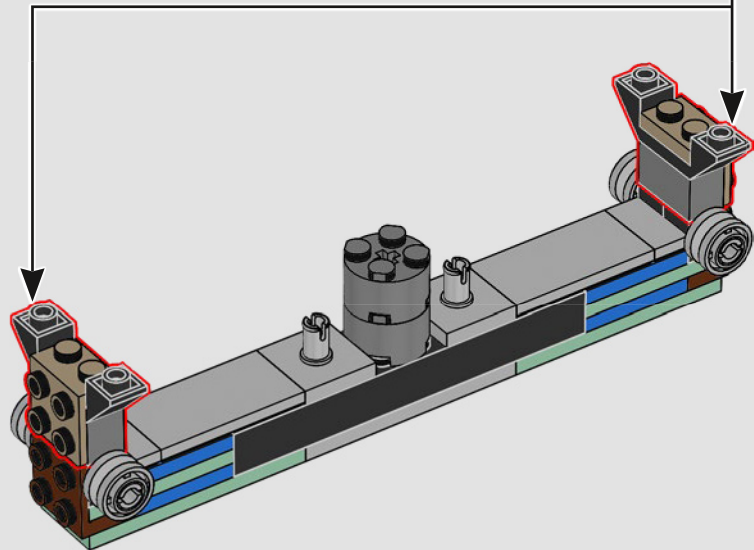
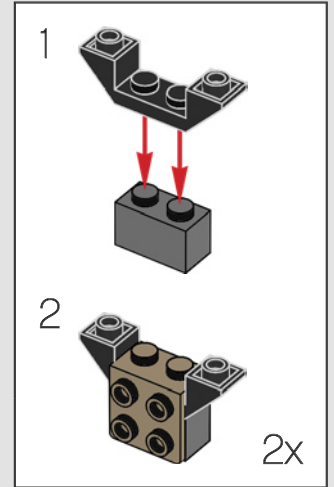

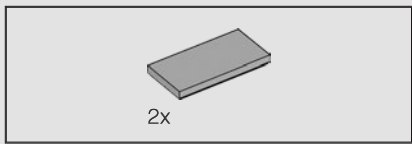

222

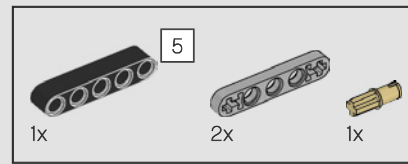
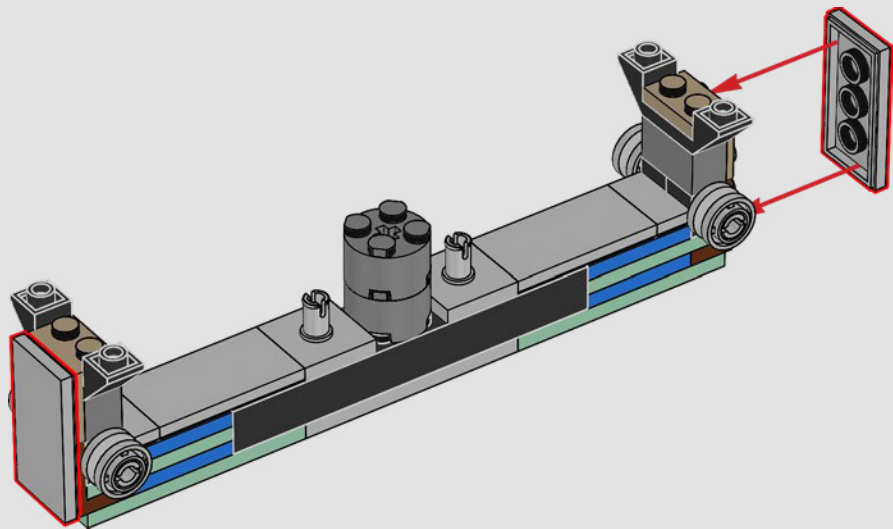

223

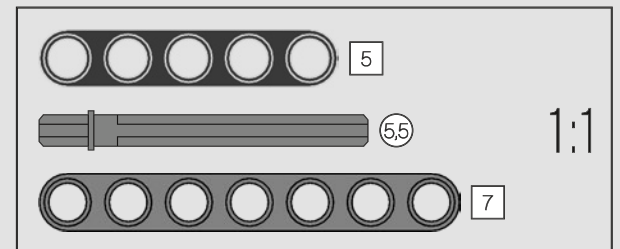
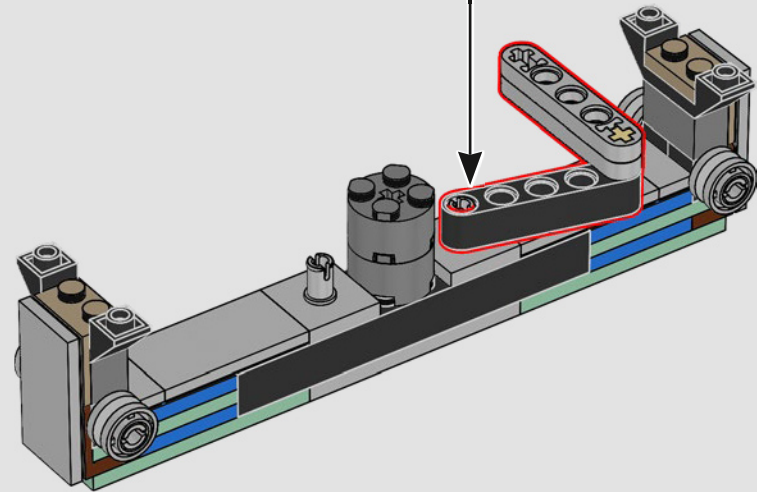
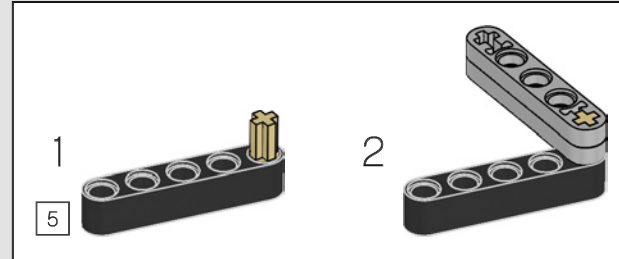

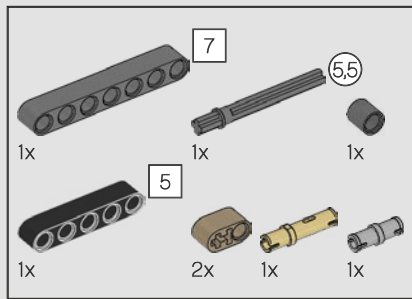

224

1

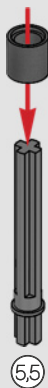

2

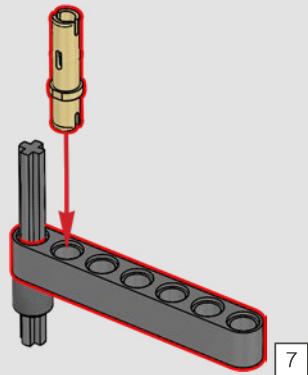

3

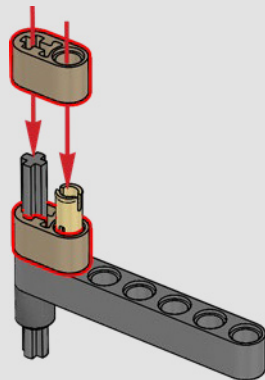

4

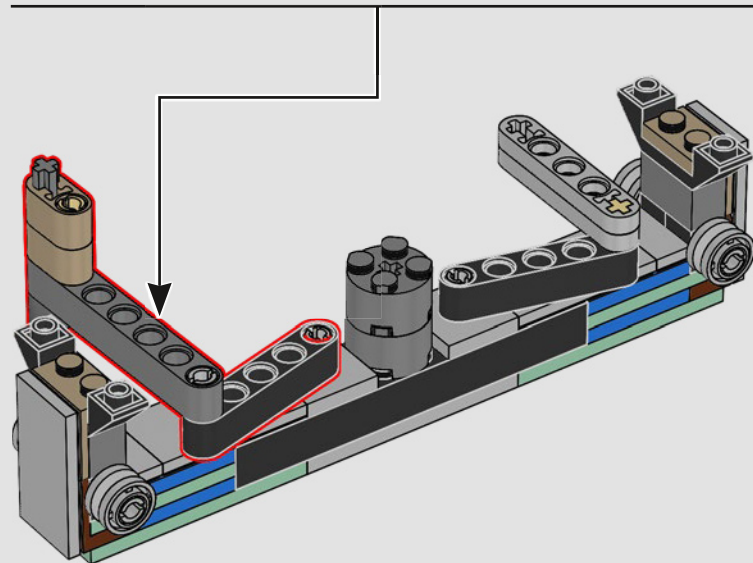
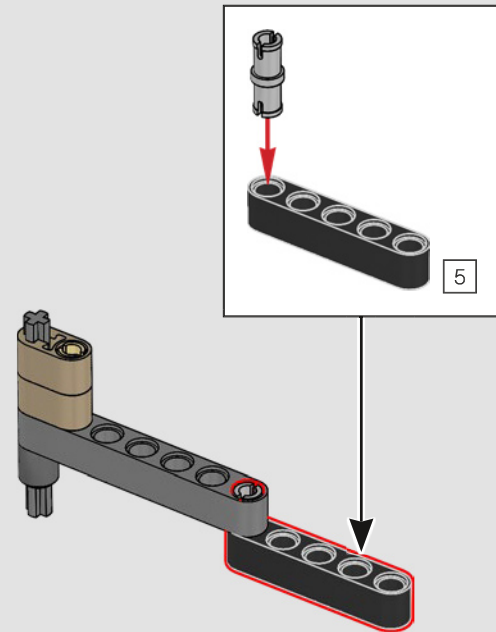

225

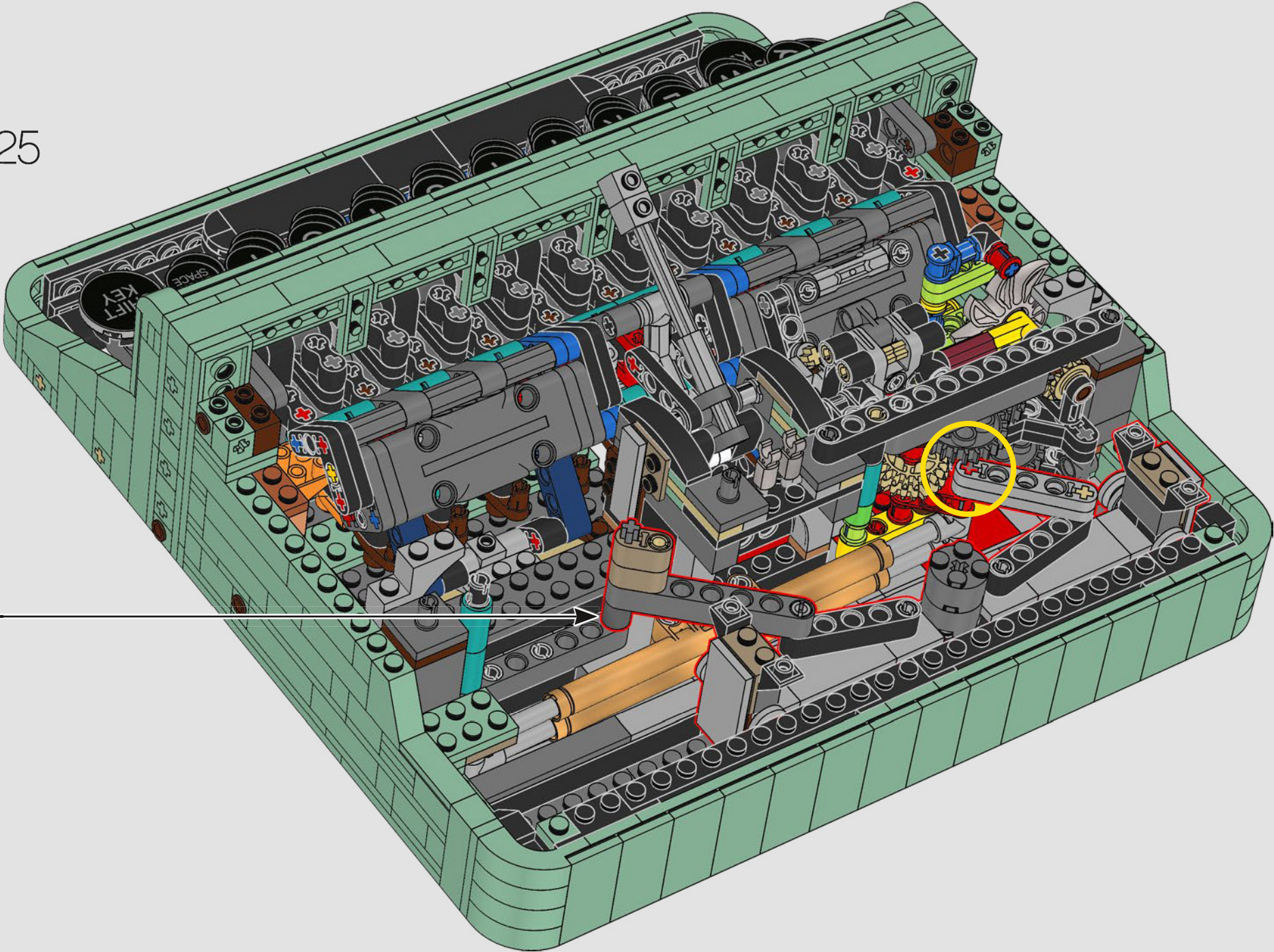

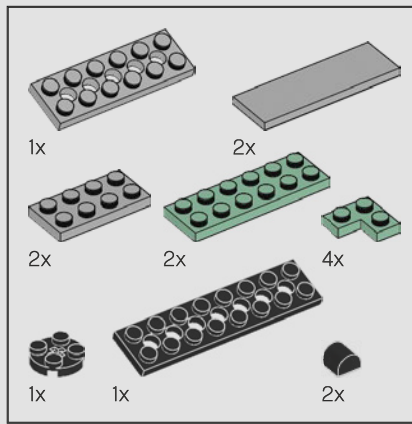

1

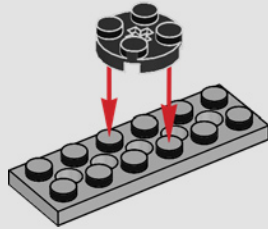

2

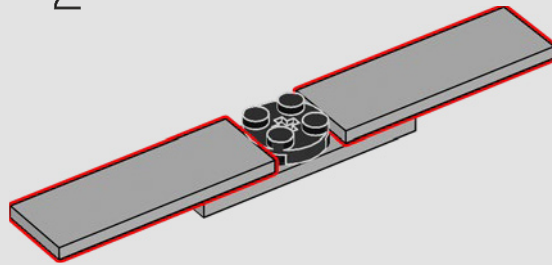

3

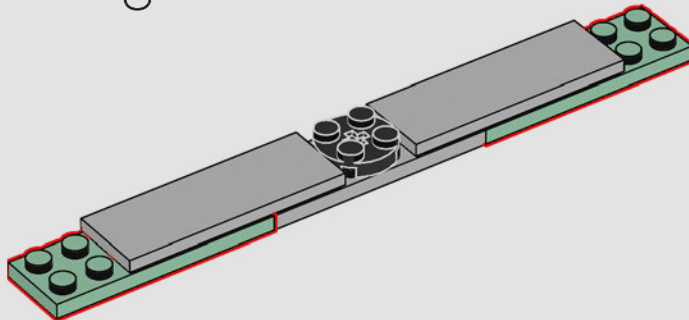

226

4

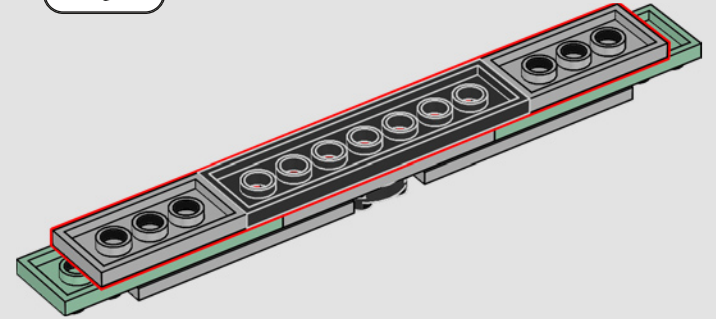

5

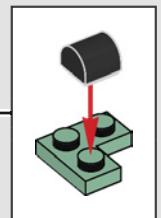
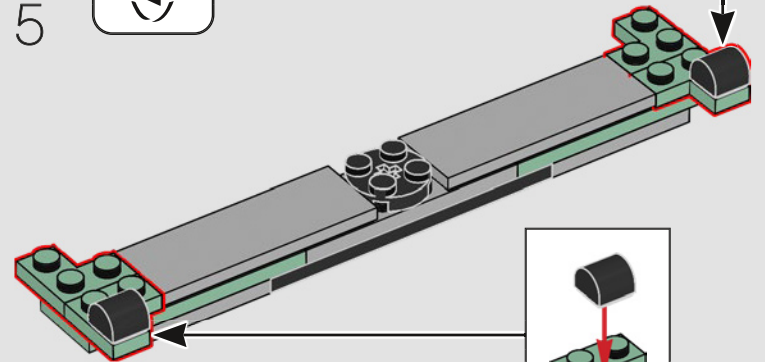
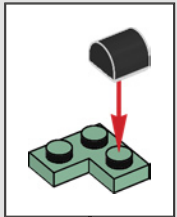
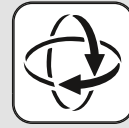

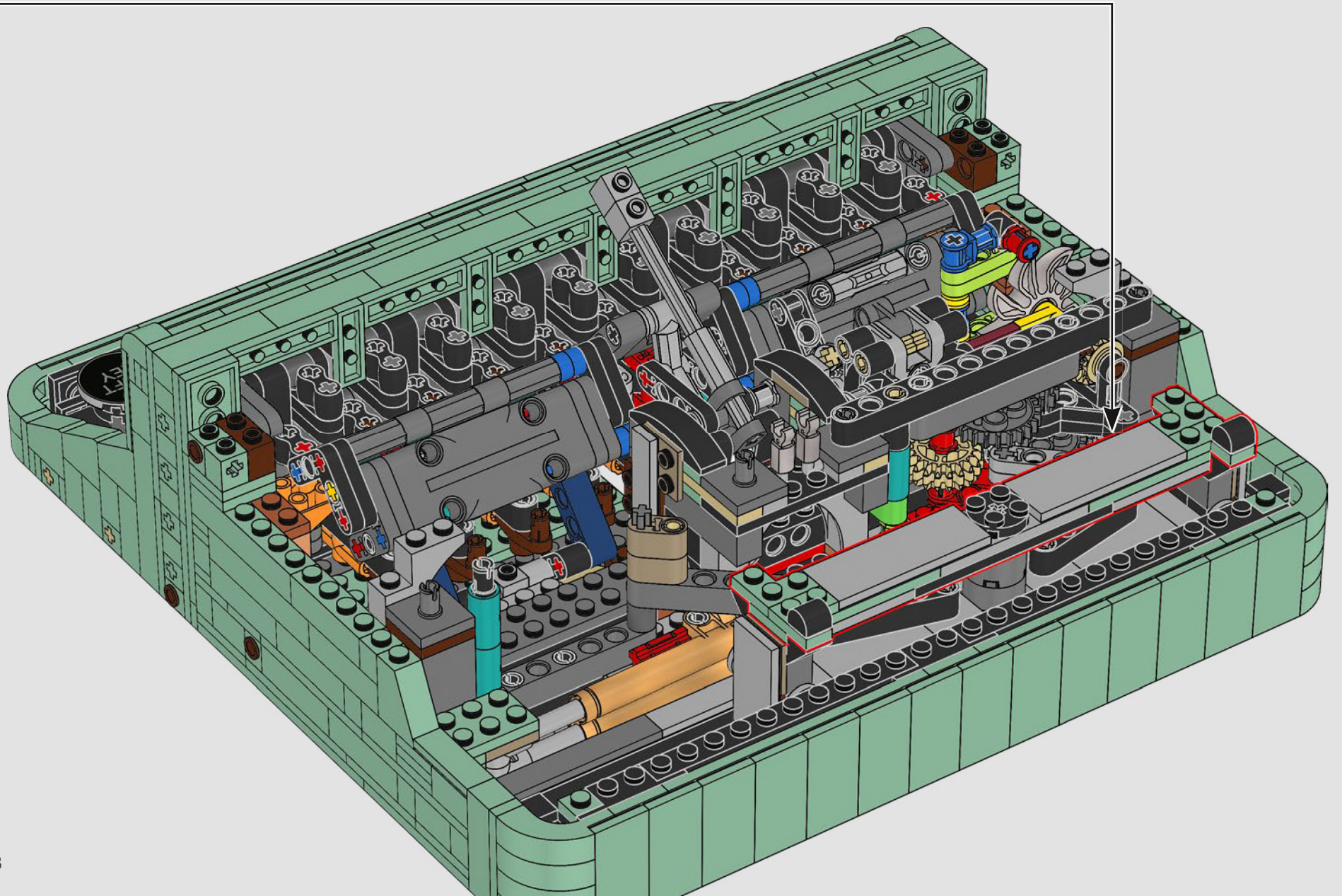

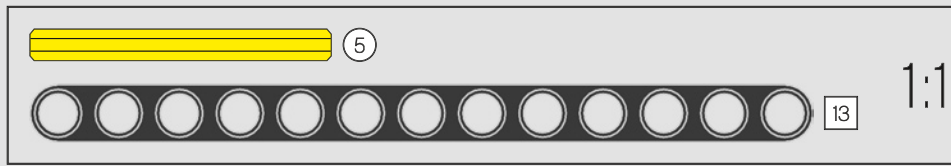
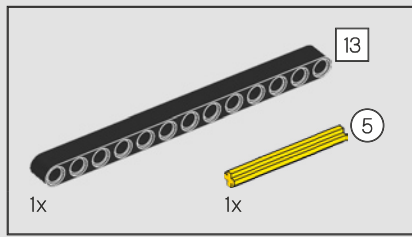

227

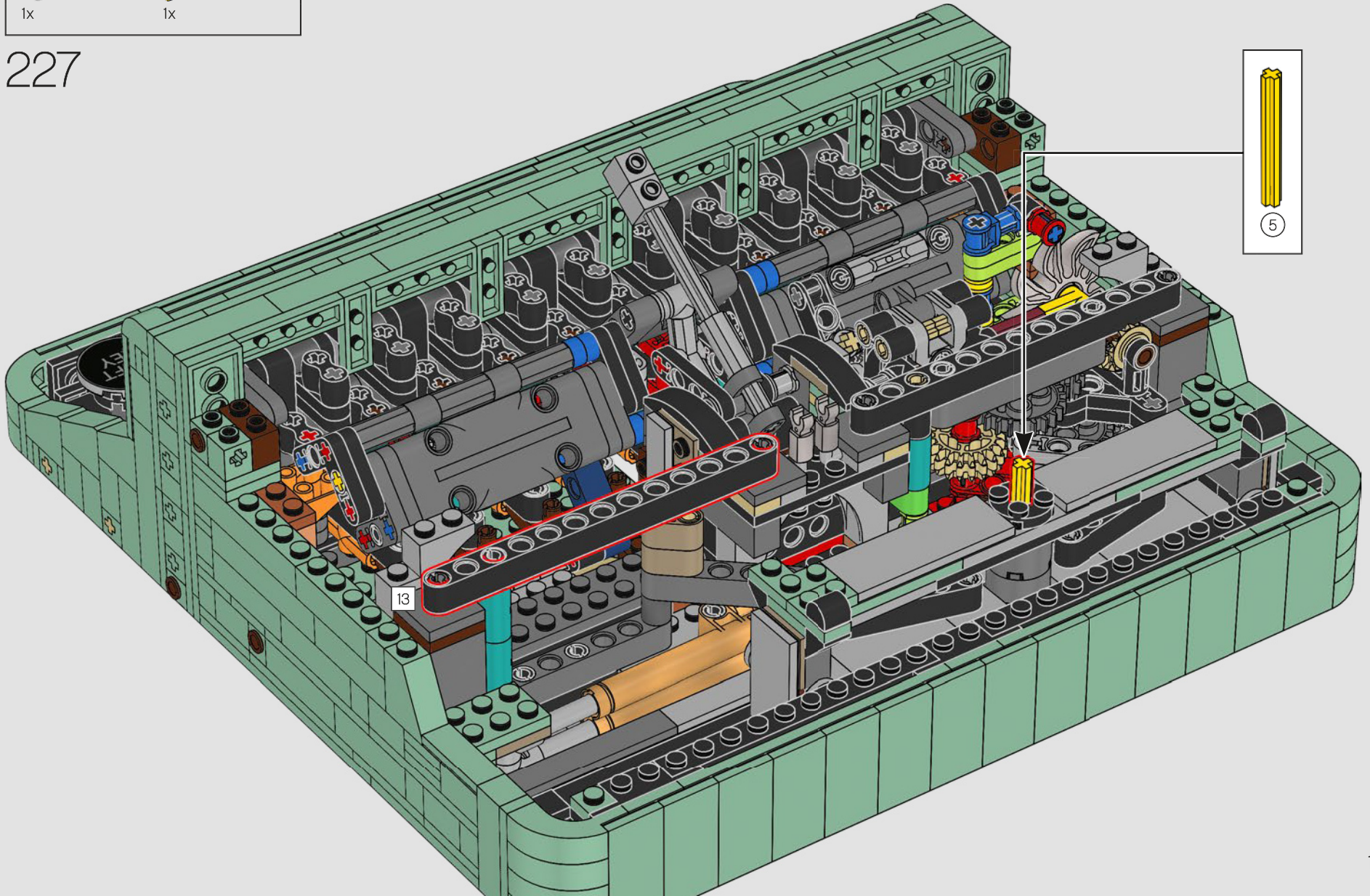

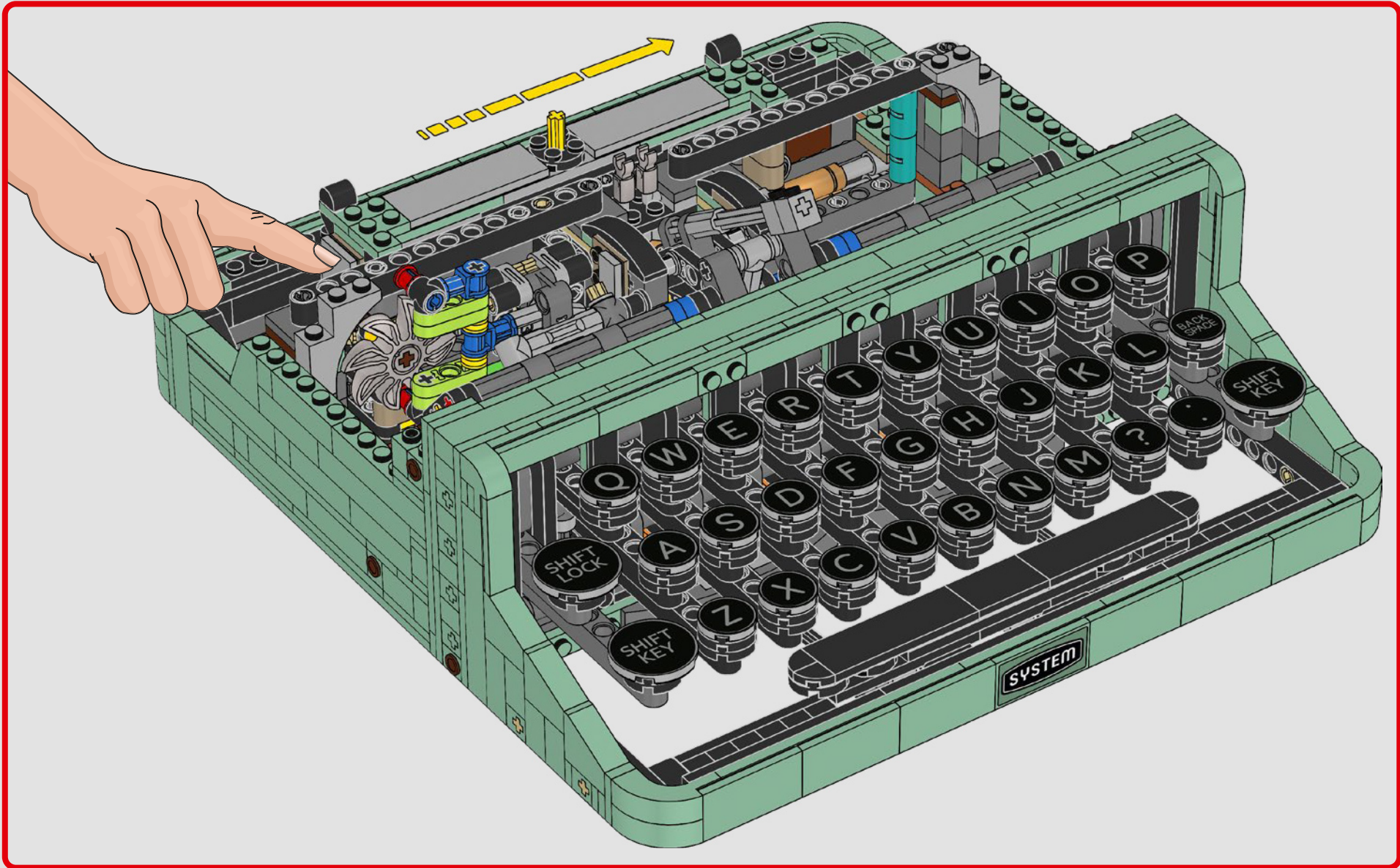

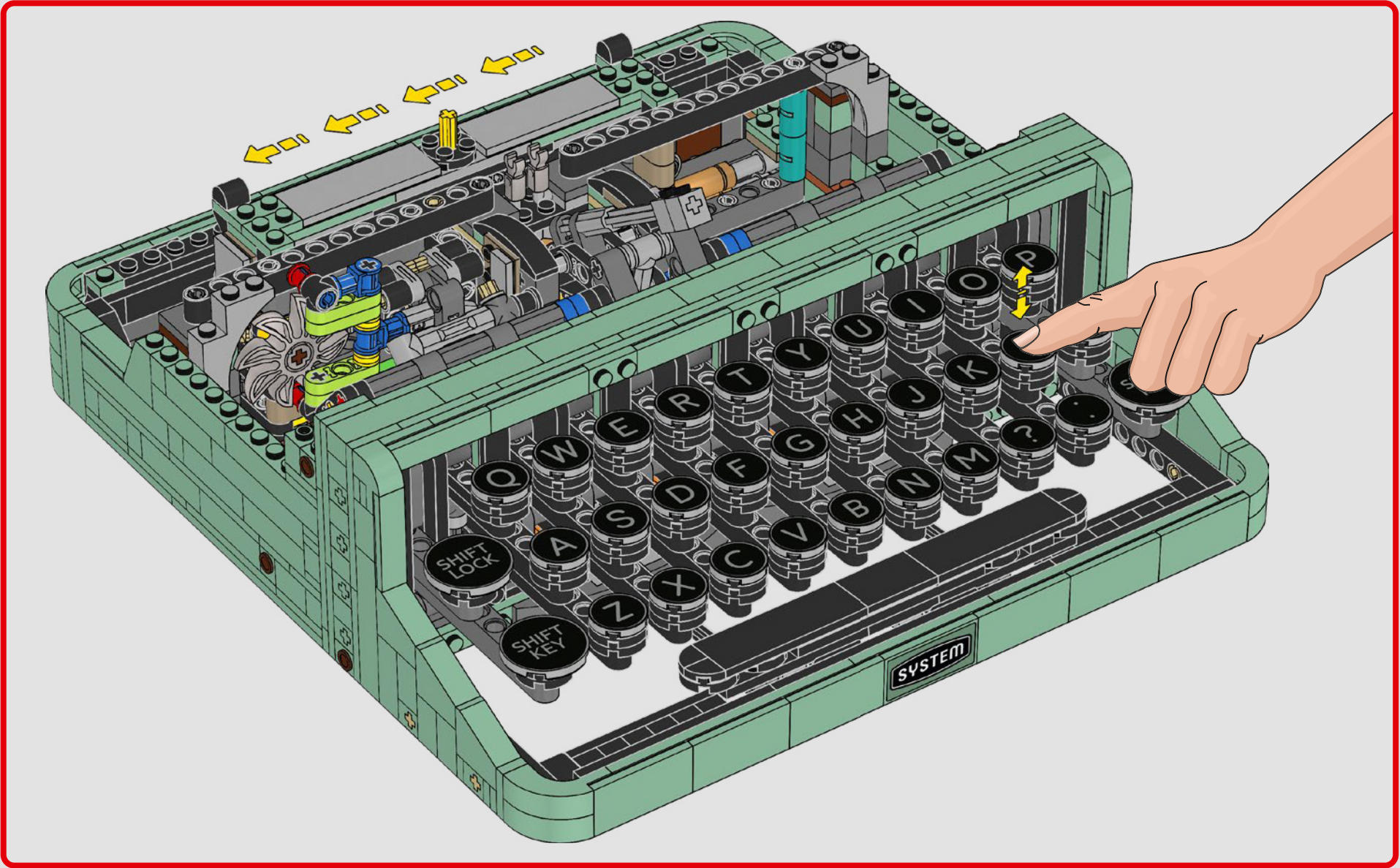

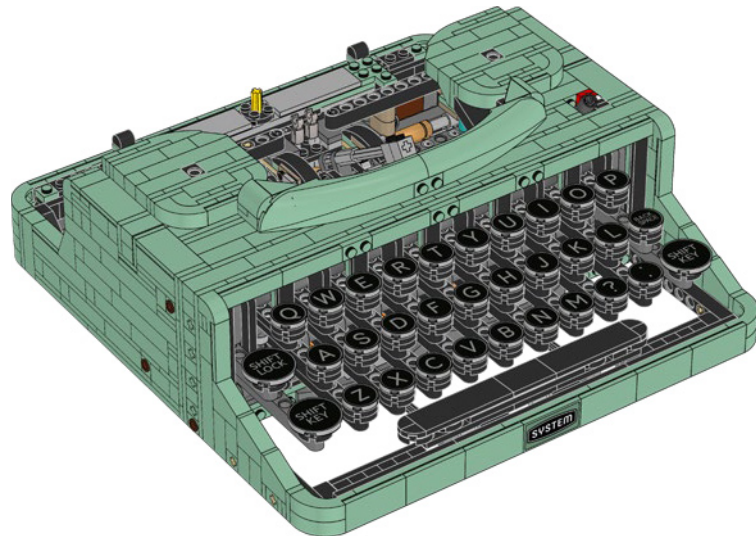
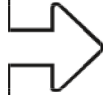

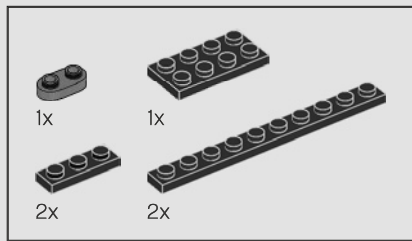

228

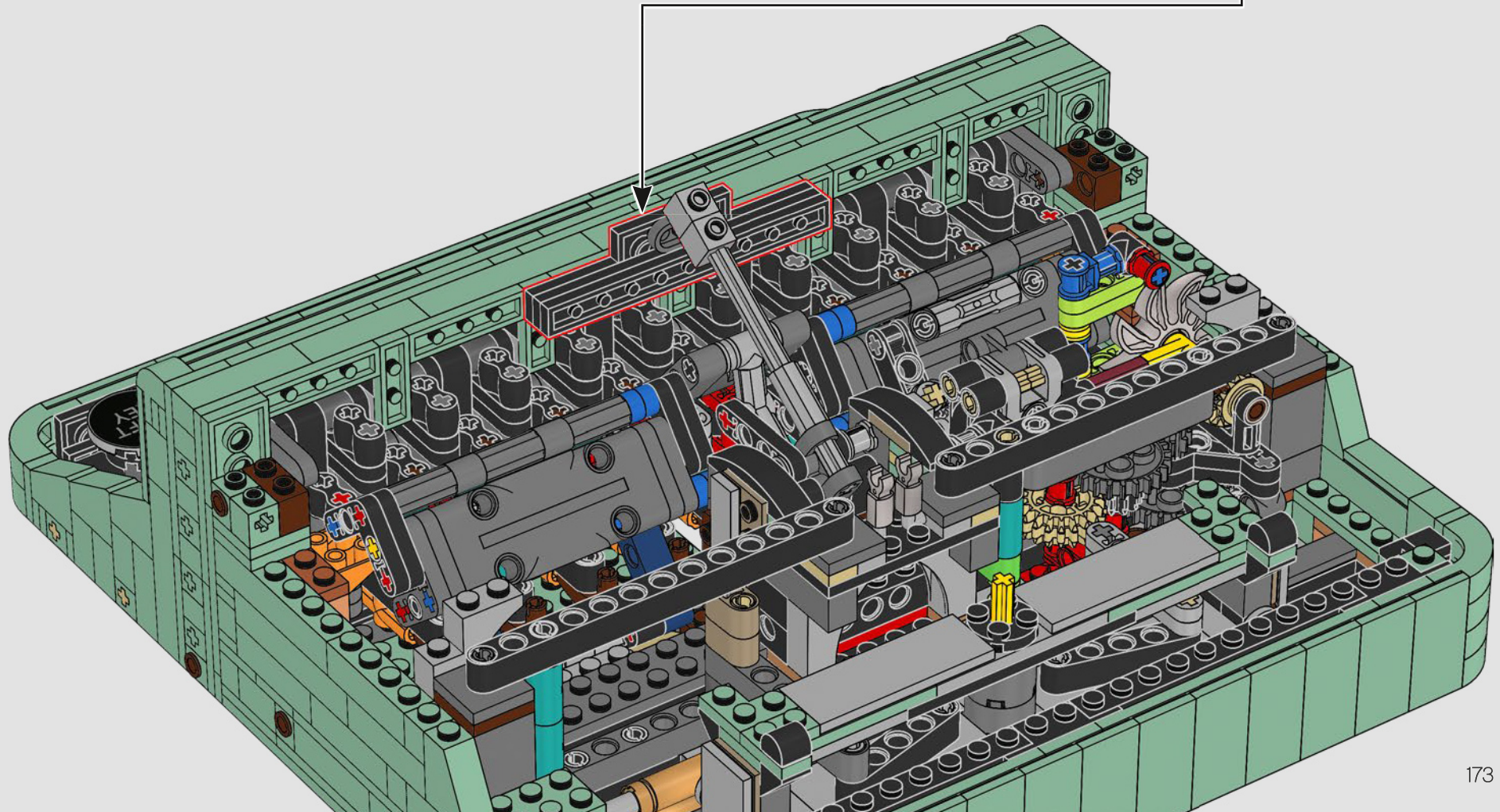
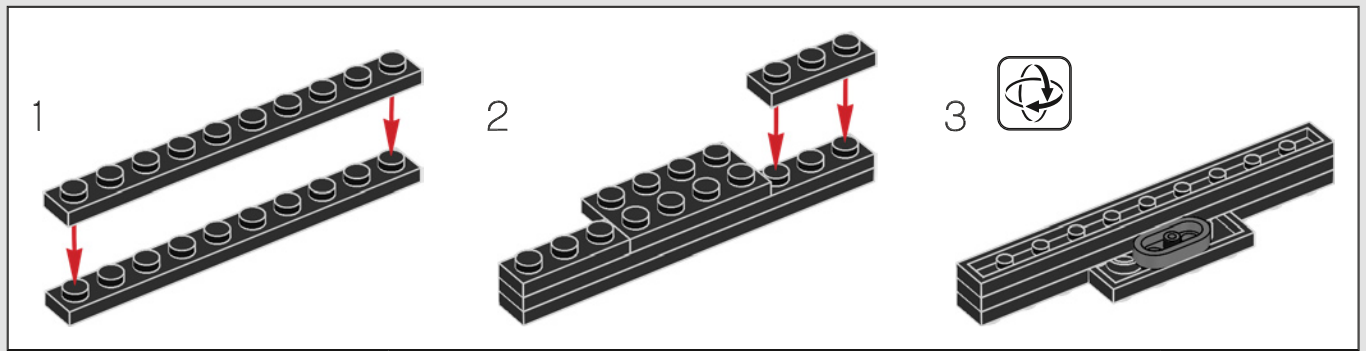

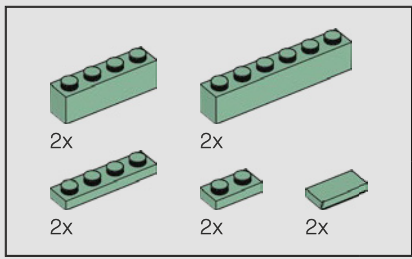

229

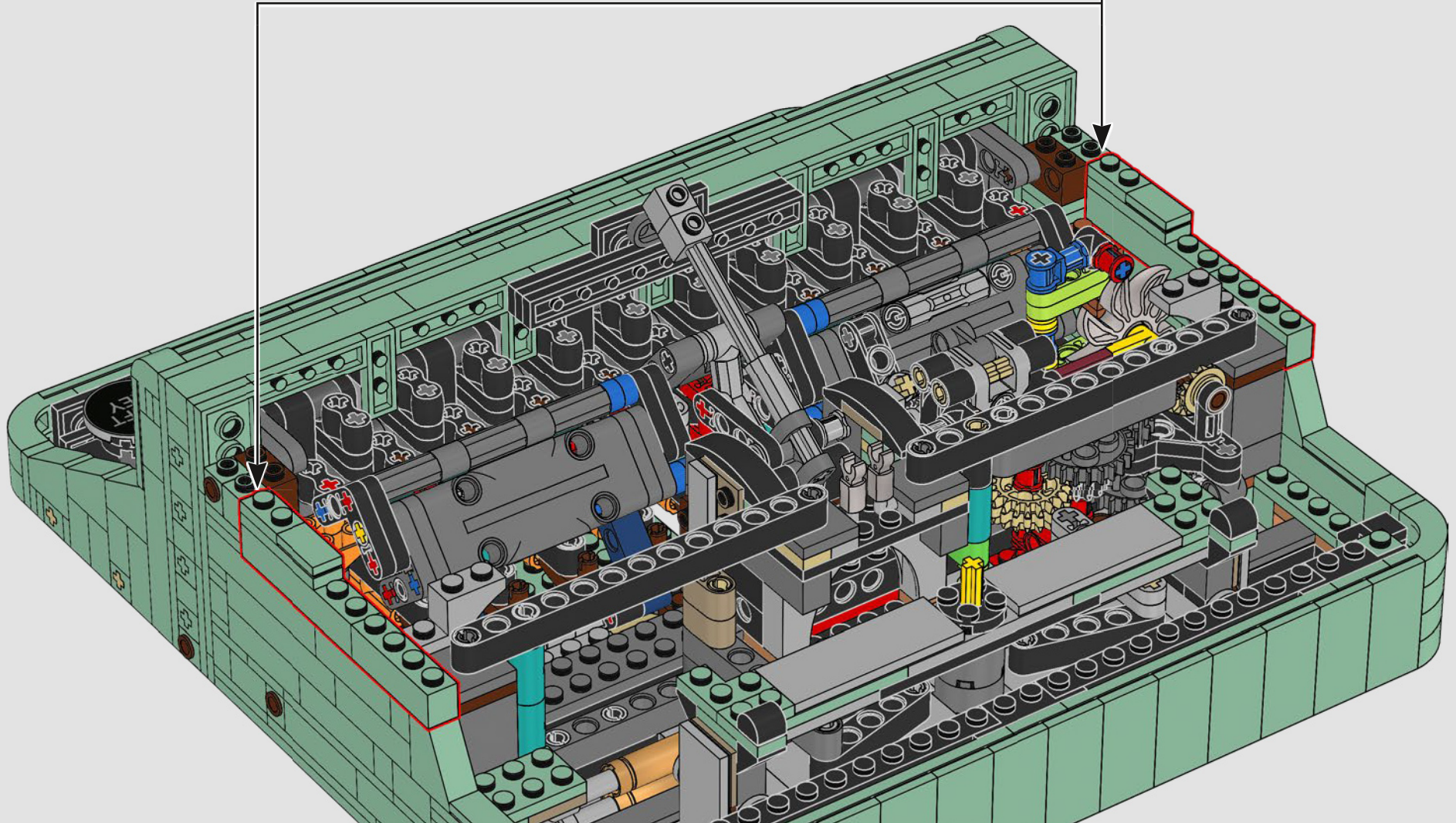
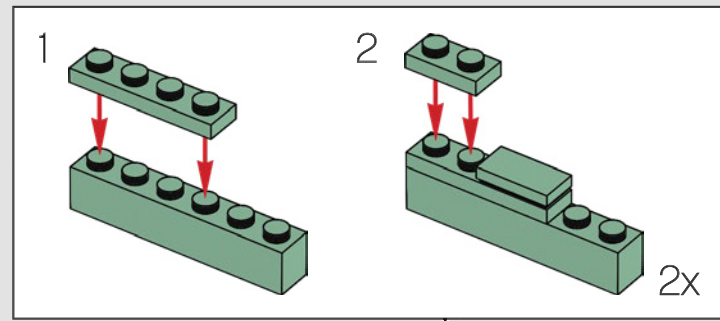

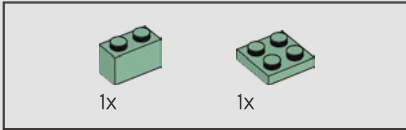
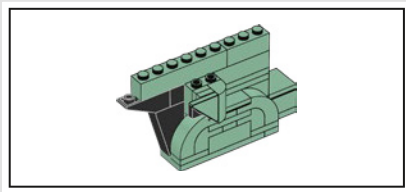

230

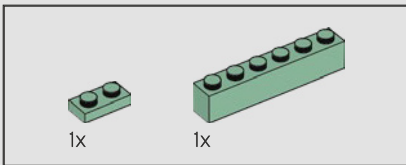
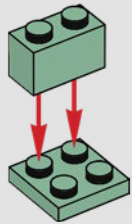

231

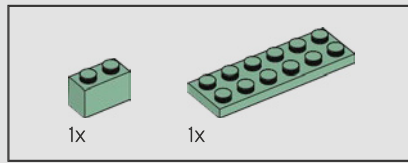
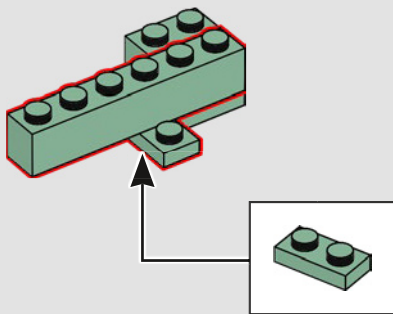

232

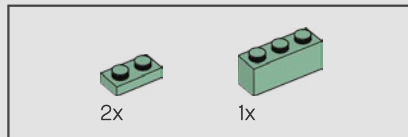
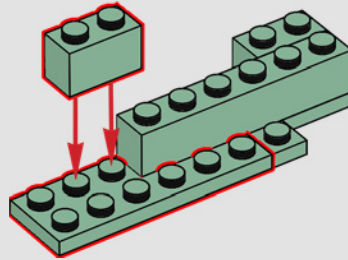

233

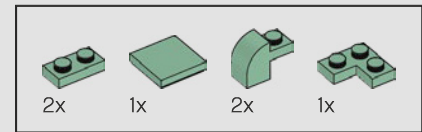
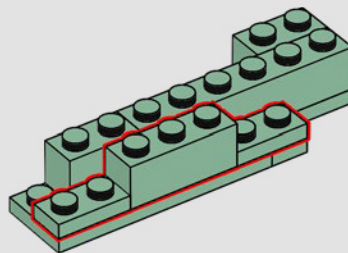

234

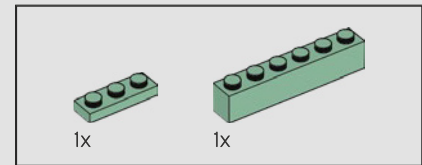
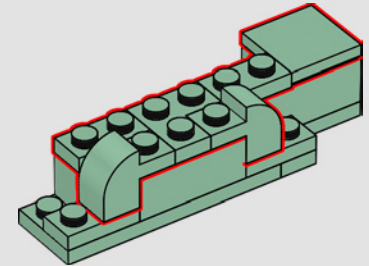

235

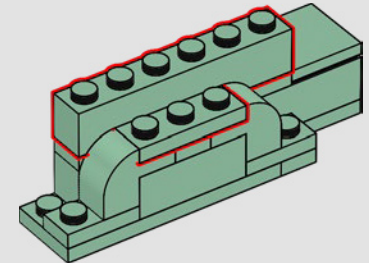

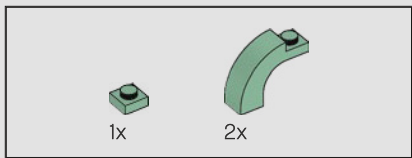

236

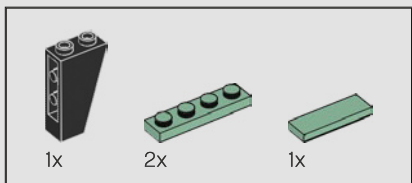
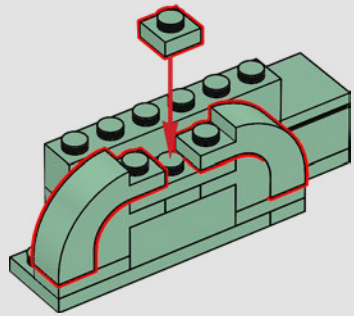

237

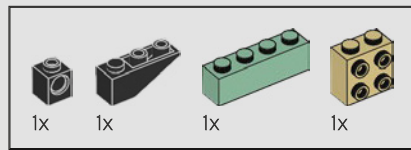
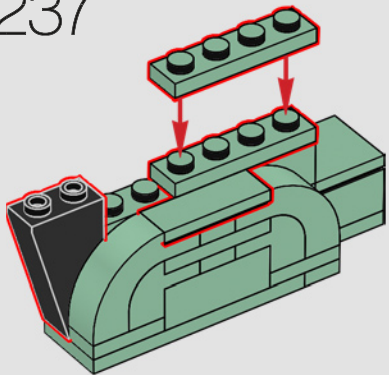

238

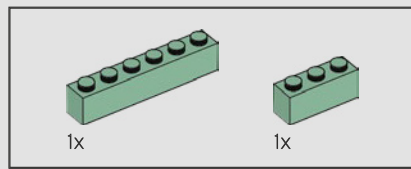
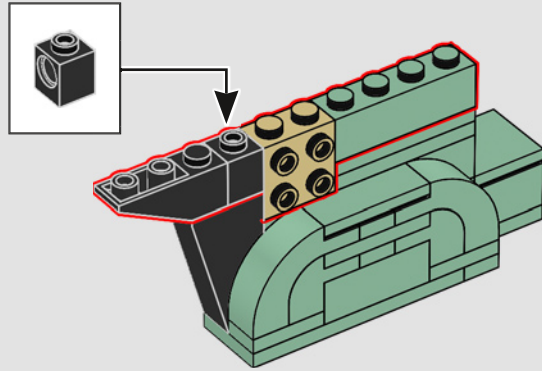

239

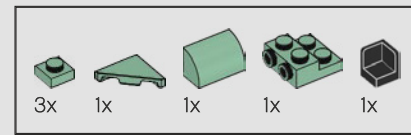
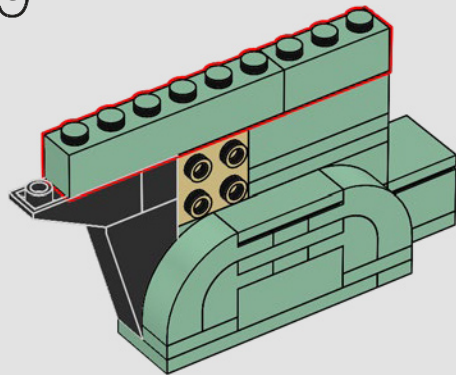

240

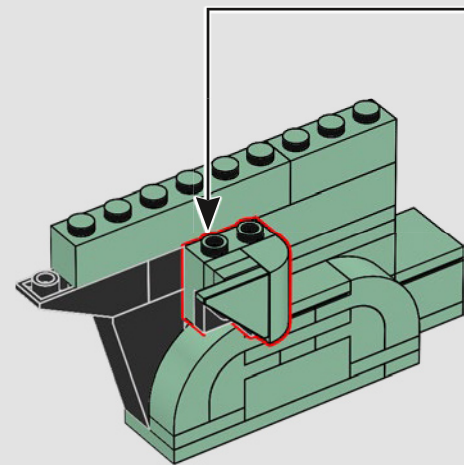
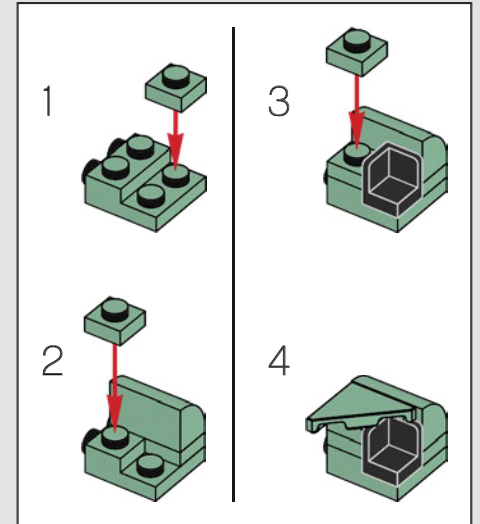

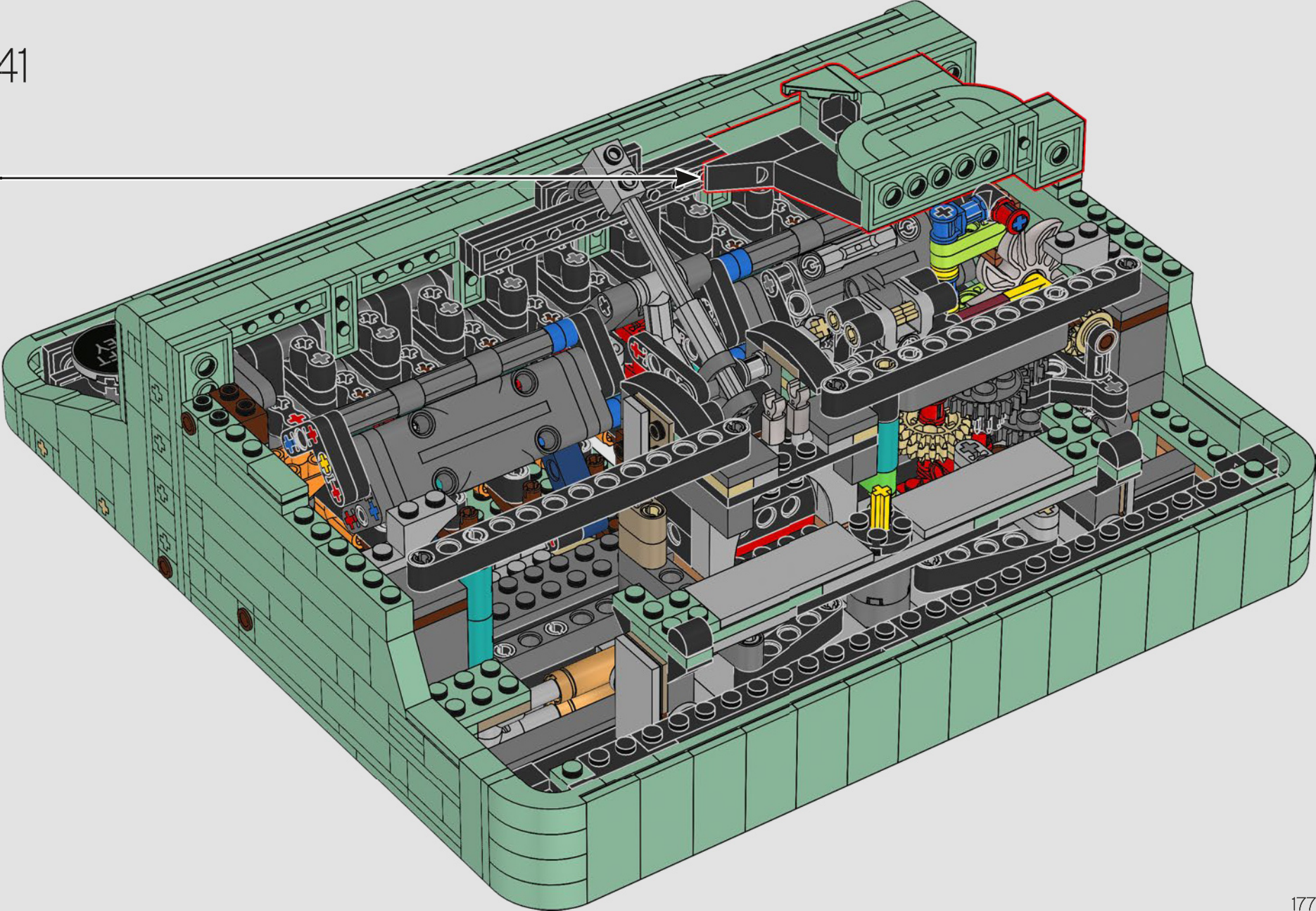

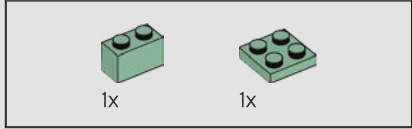
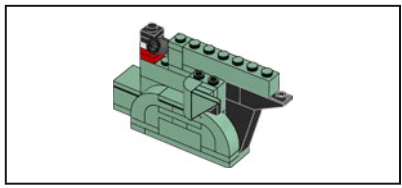

242

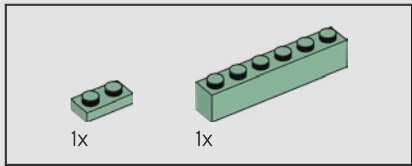
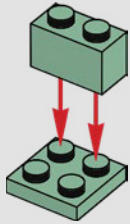

243

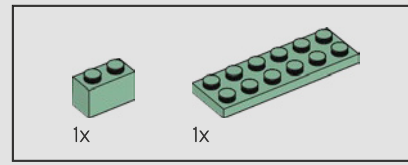
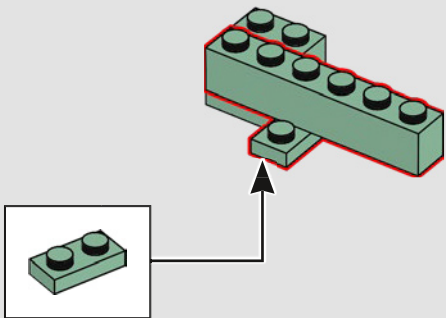

244

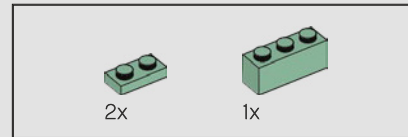
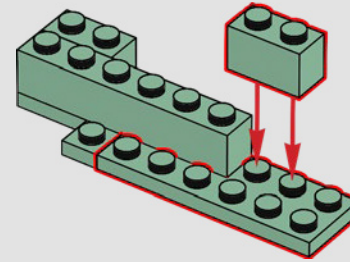

245

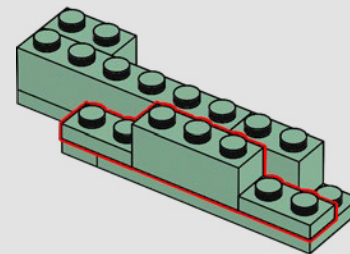

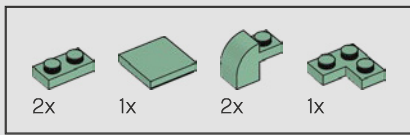

246

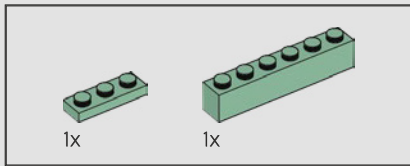
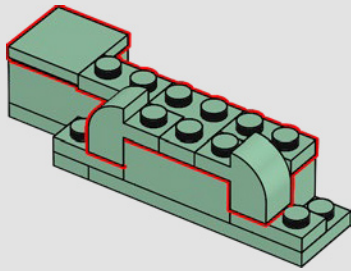

247

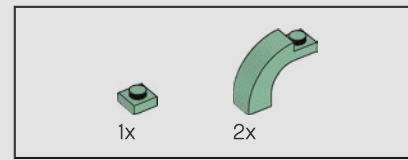
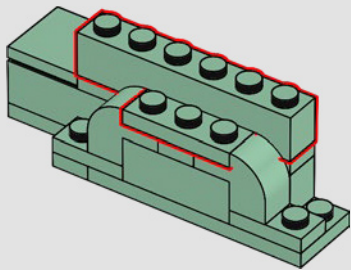

248

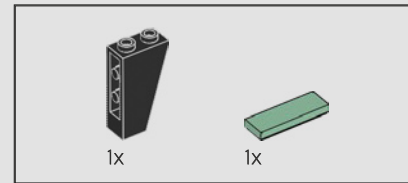
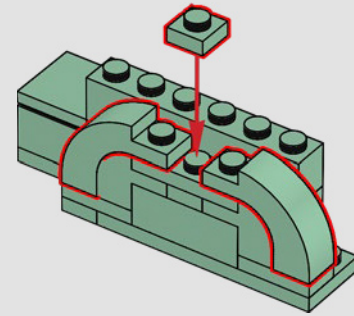

249

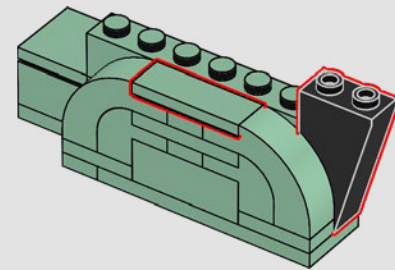

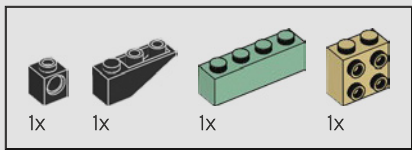

250

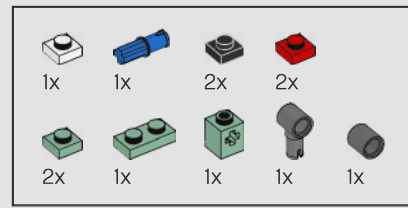
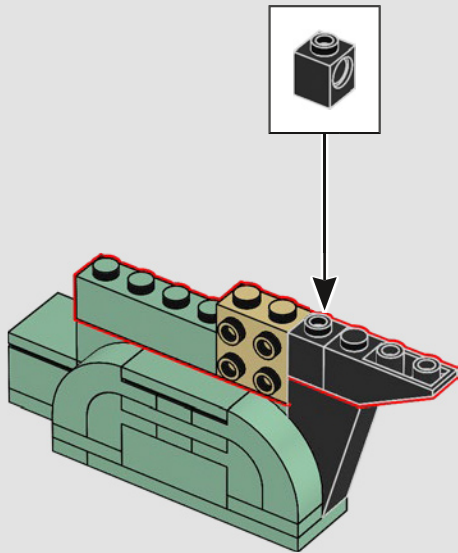

251

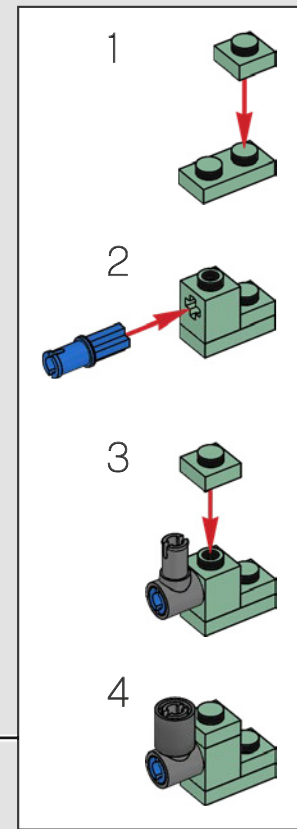
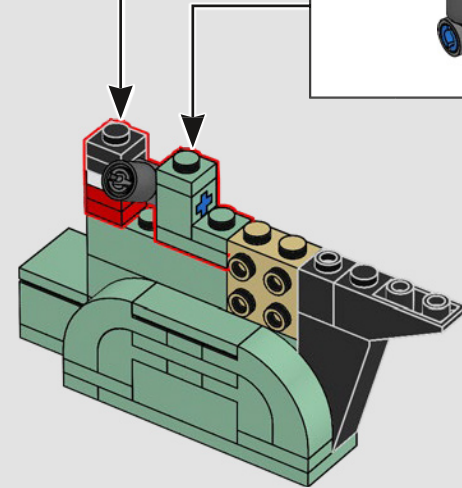
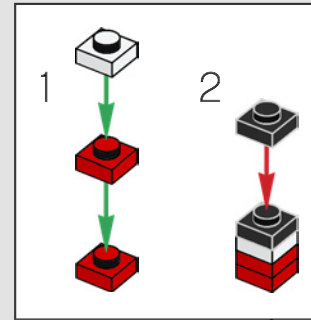

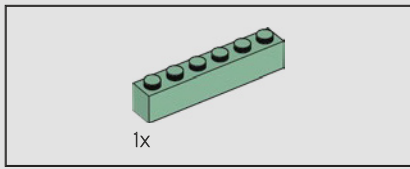

252

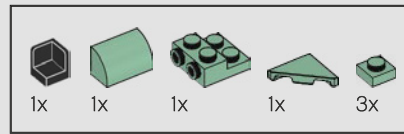
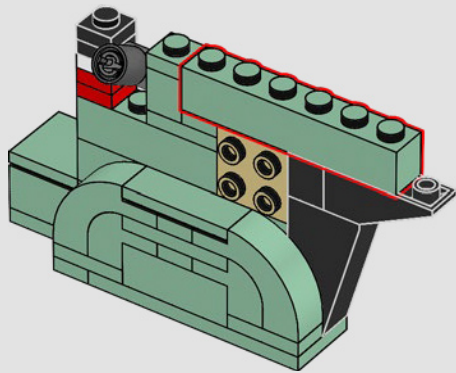

253

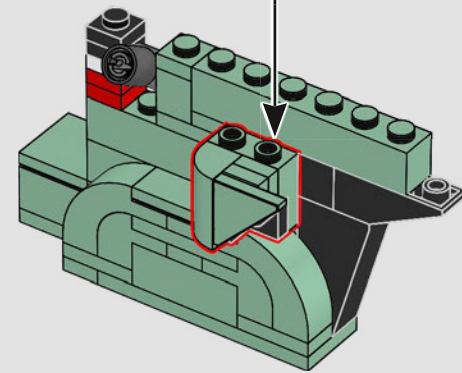
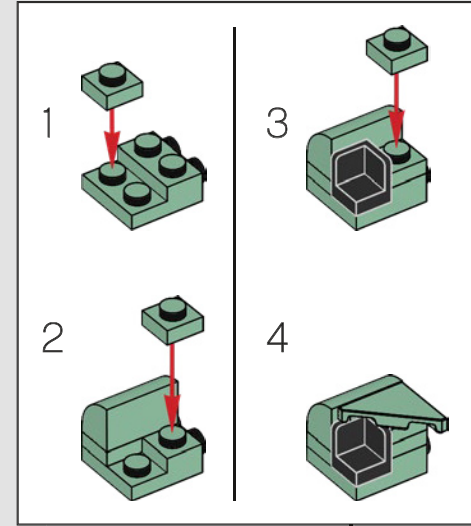

254

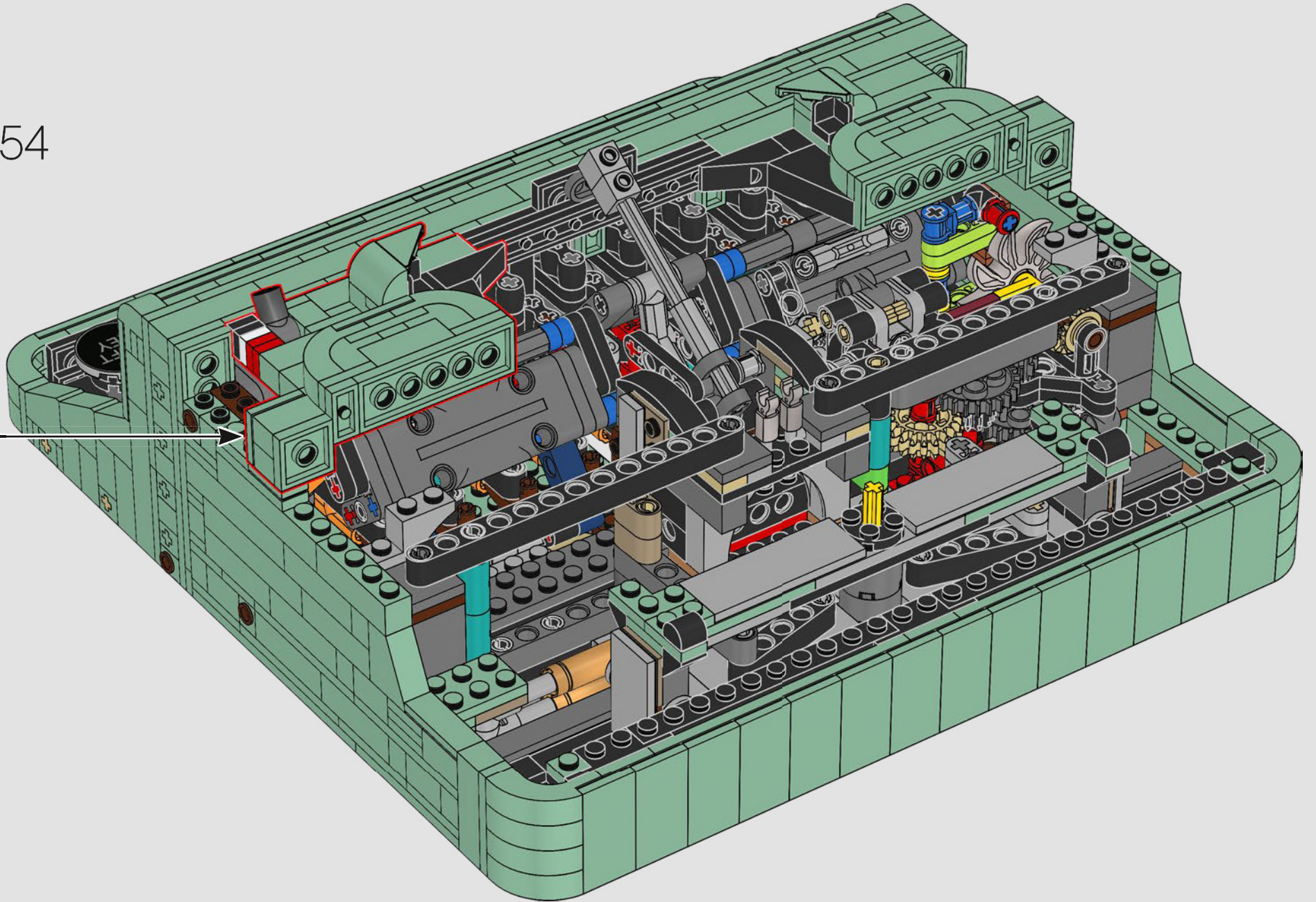

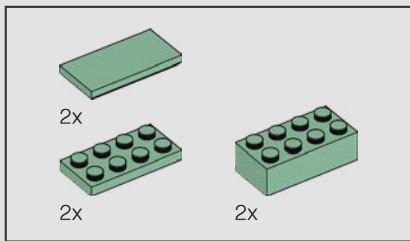

255

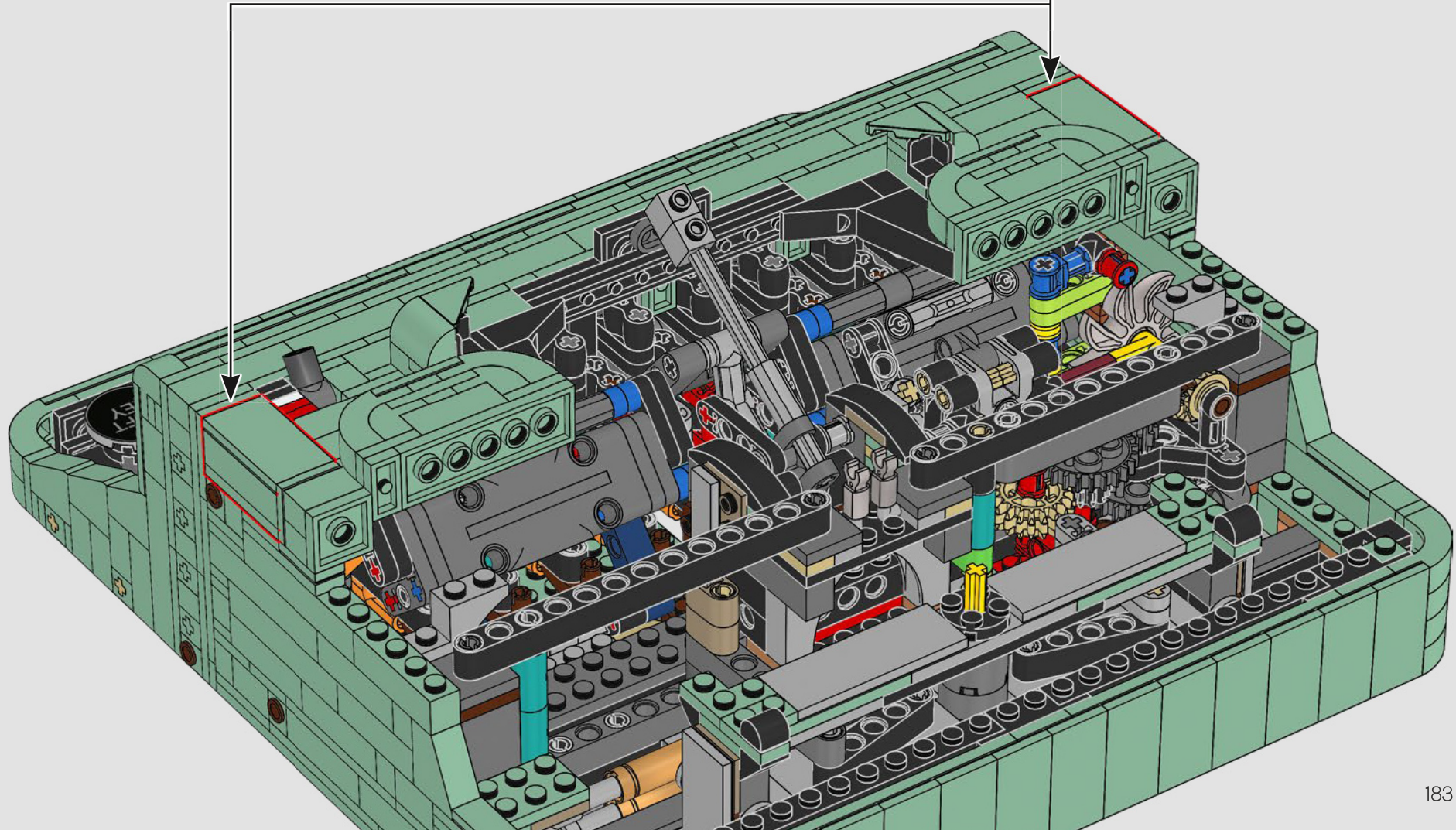
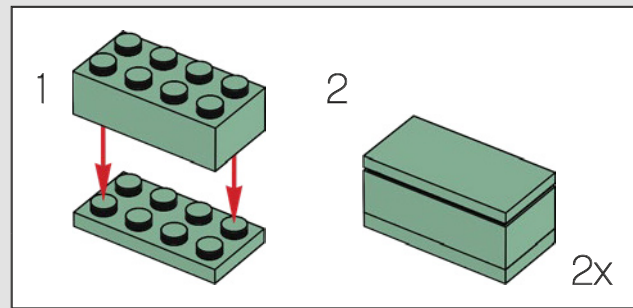

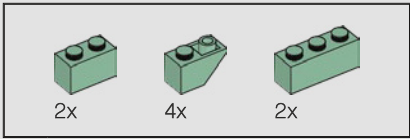

256

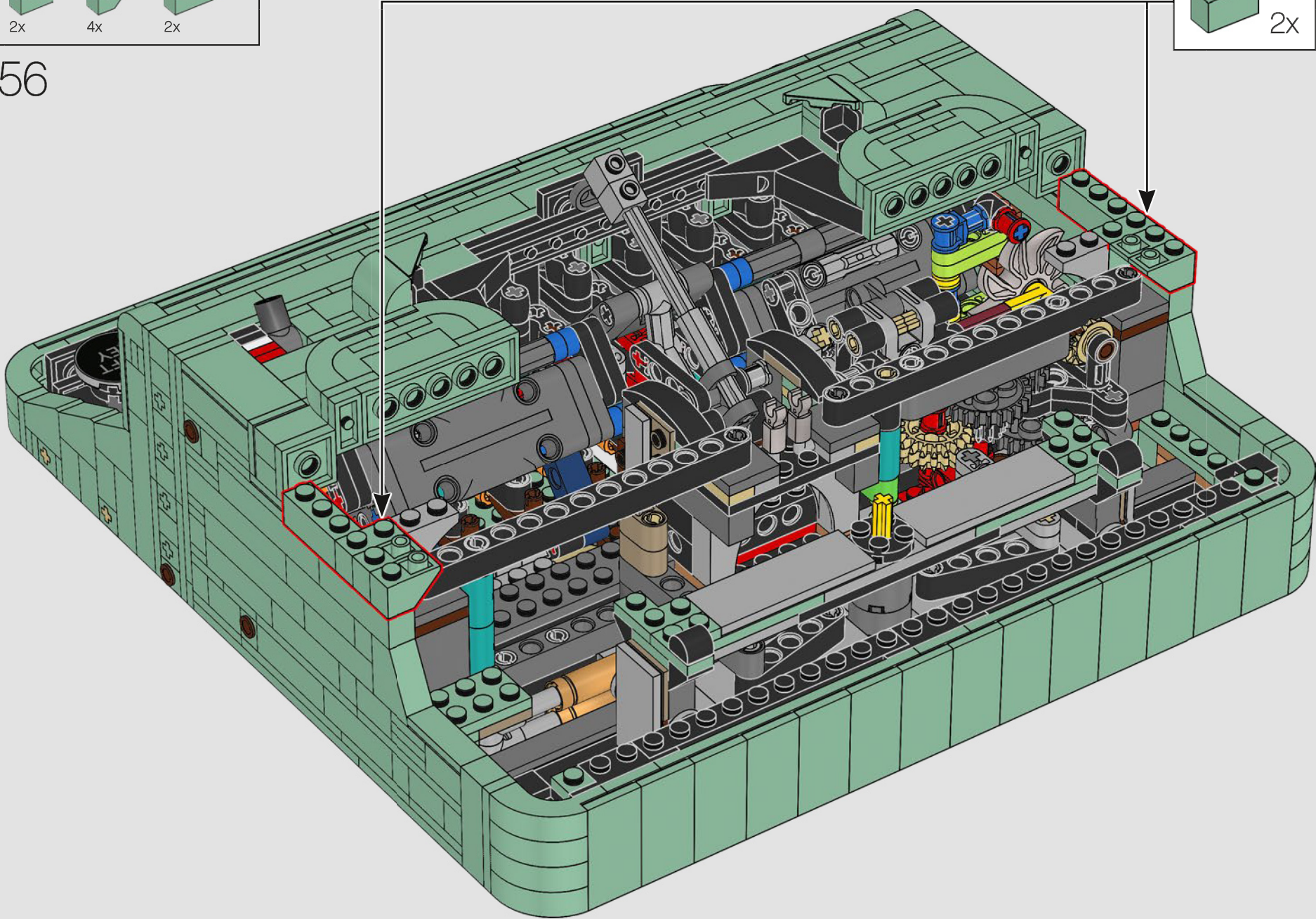
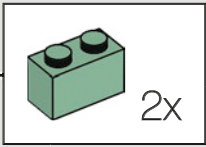

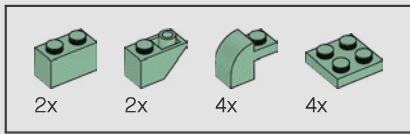

257

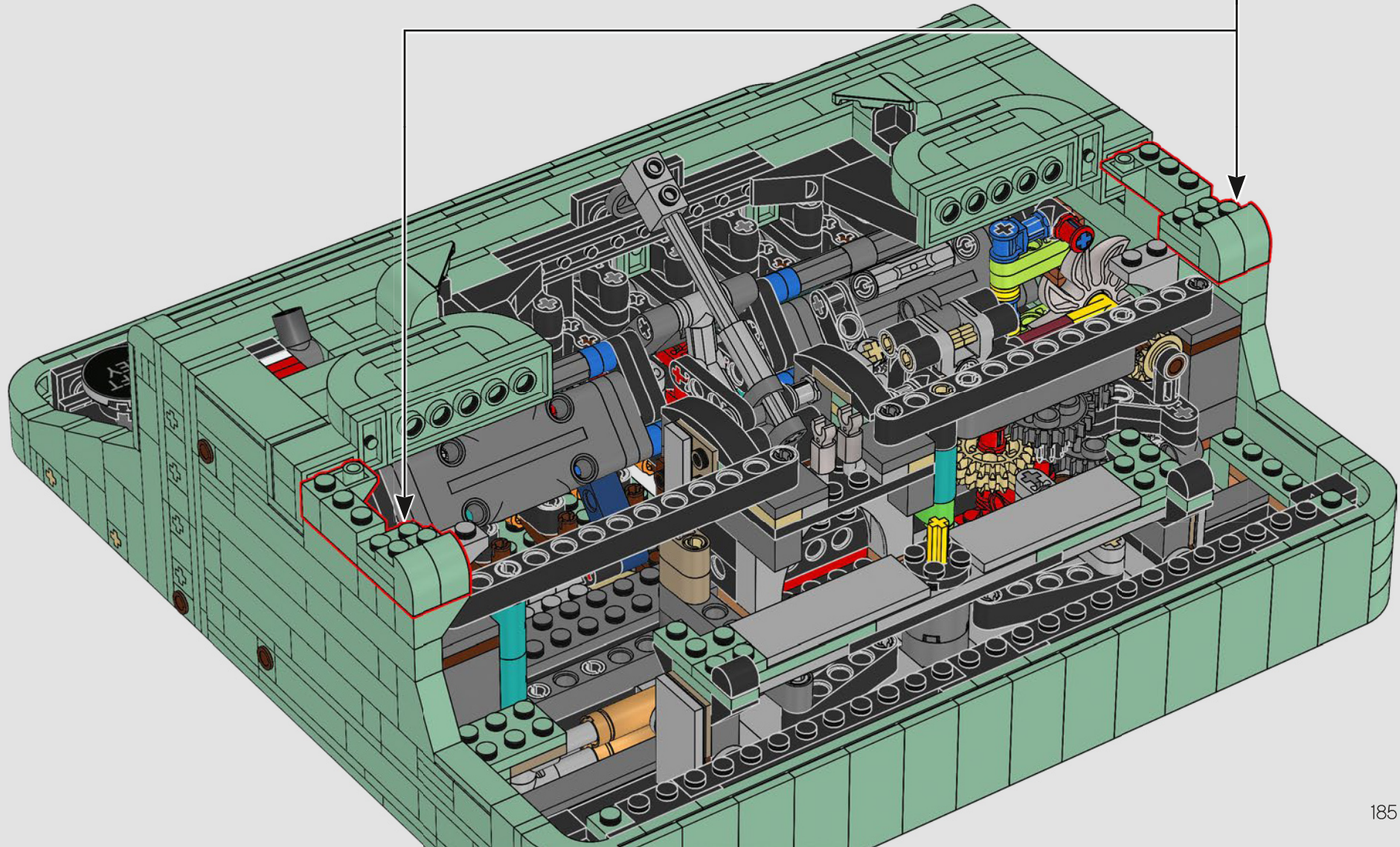
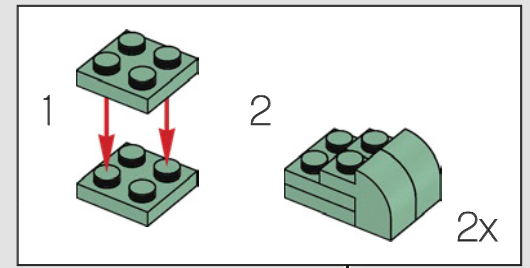

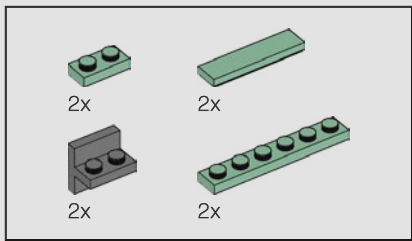

258

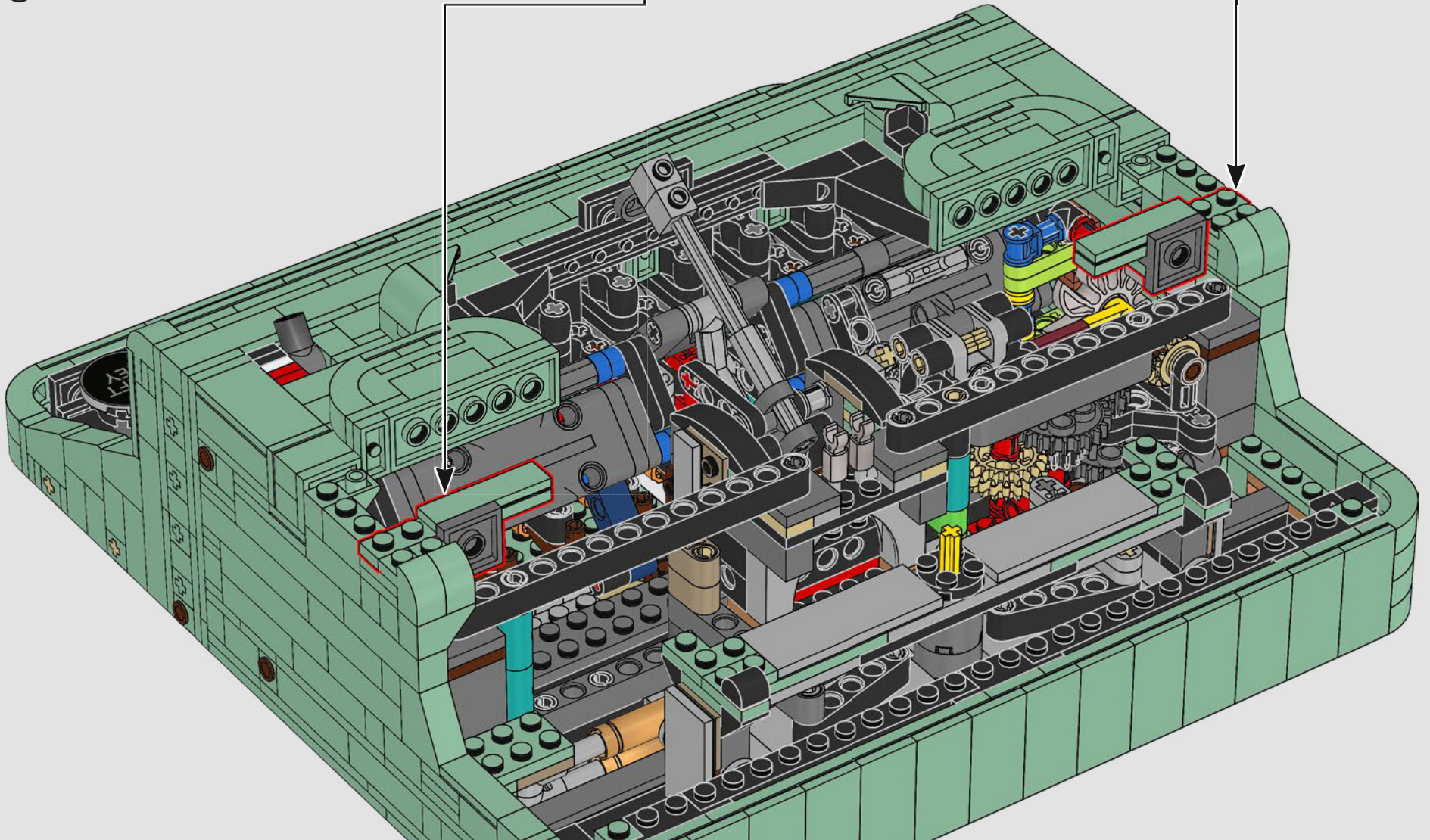
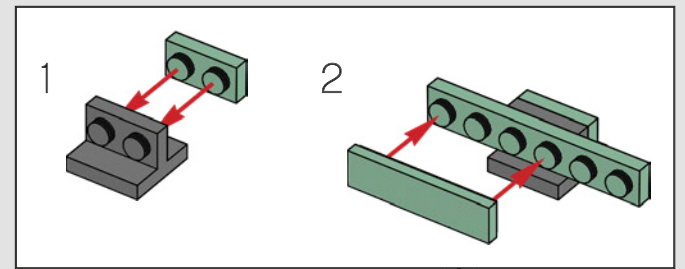
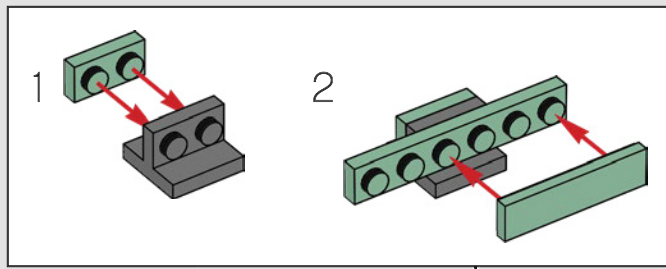

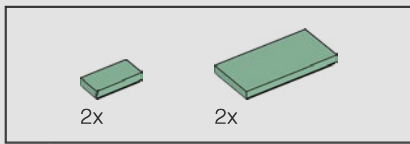

259

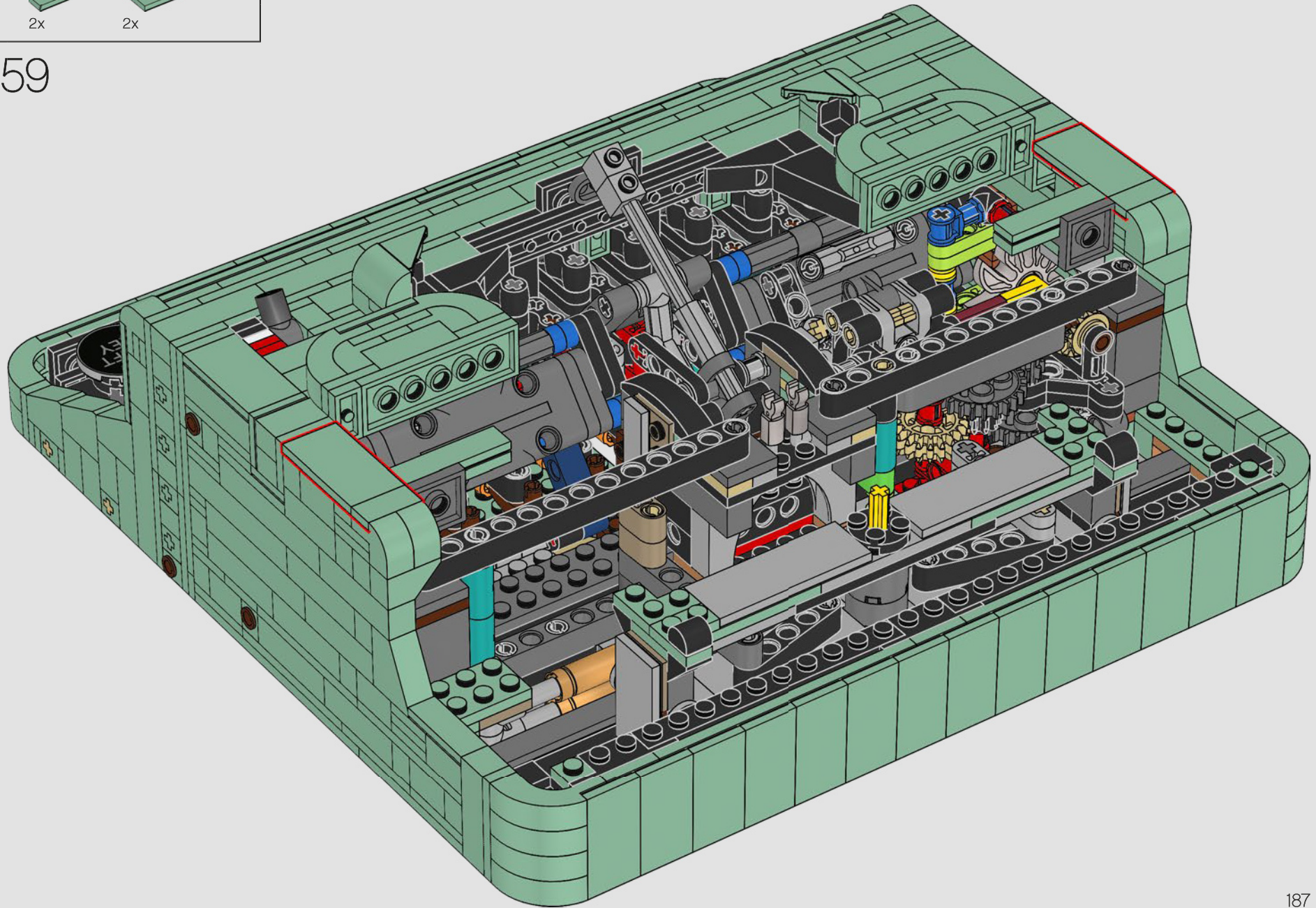

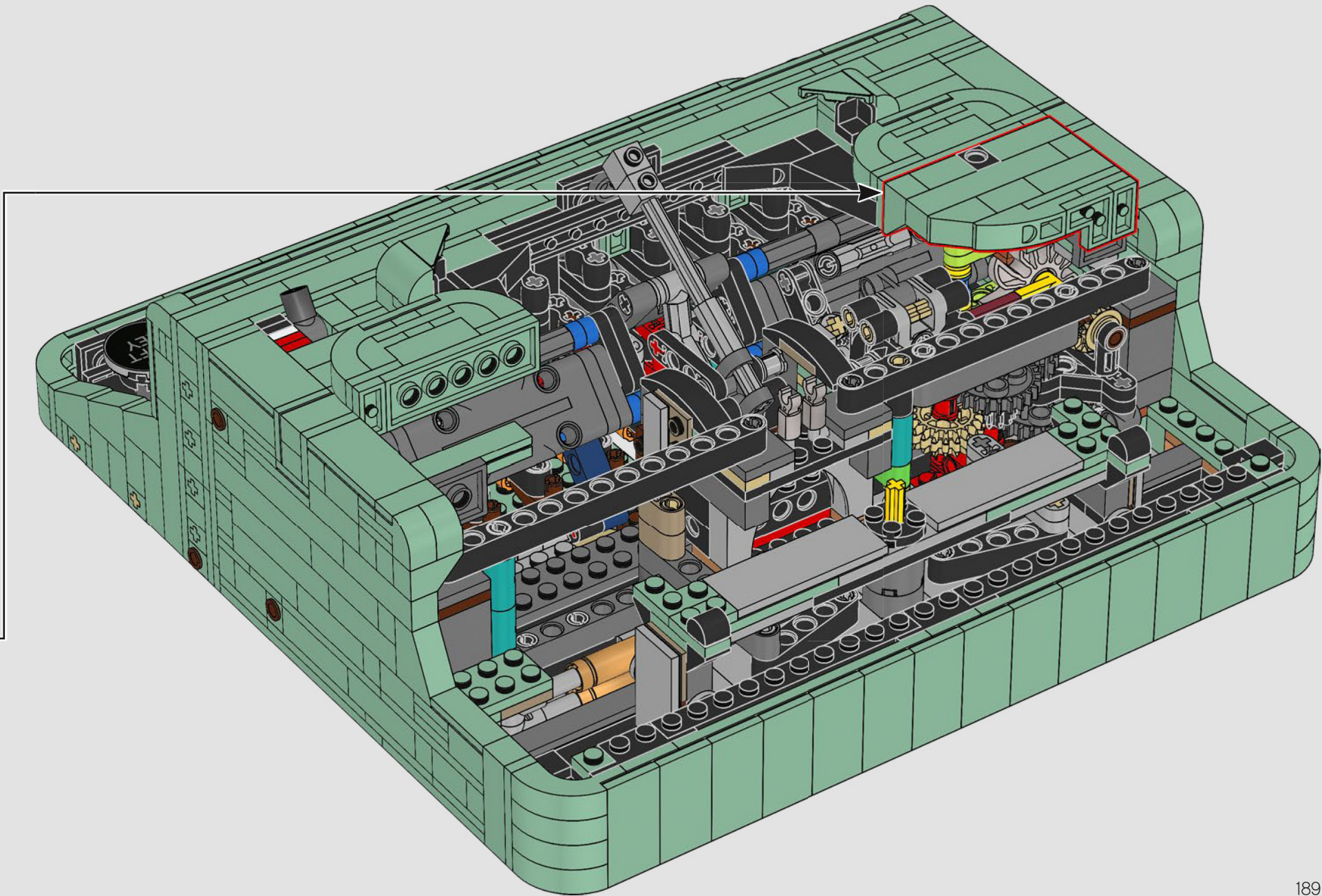

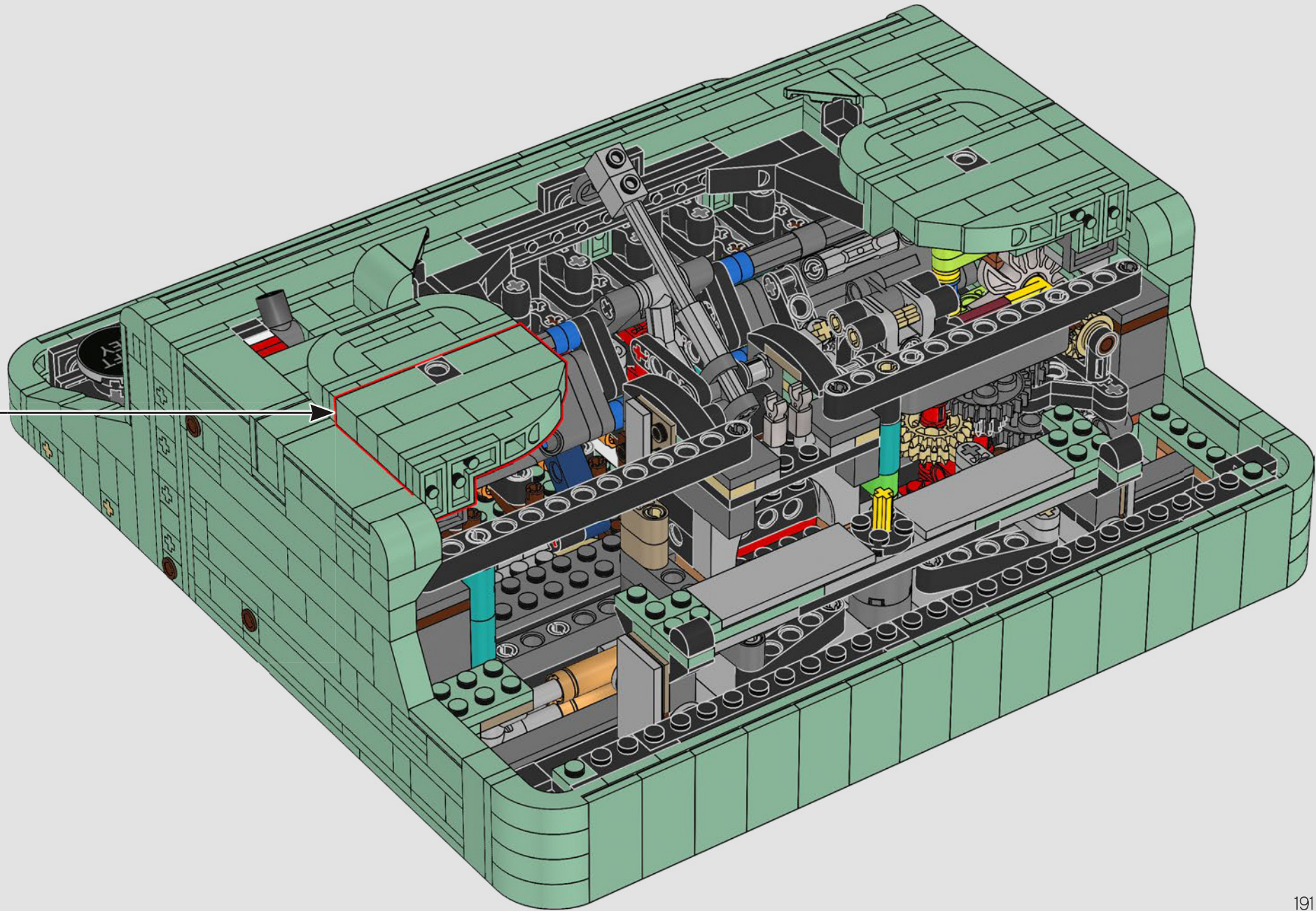

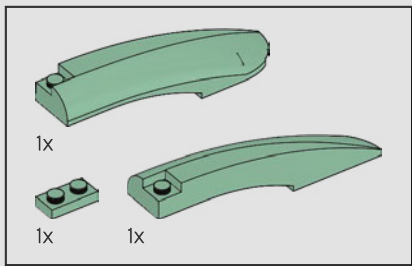

262

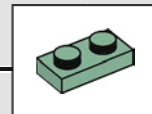
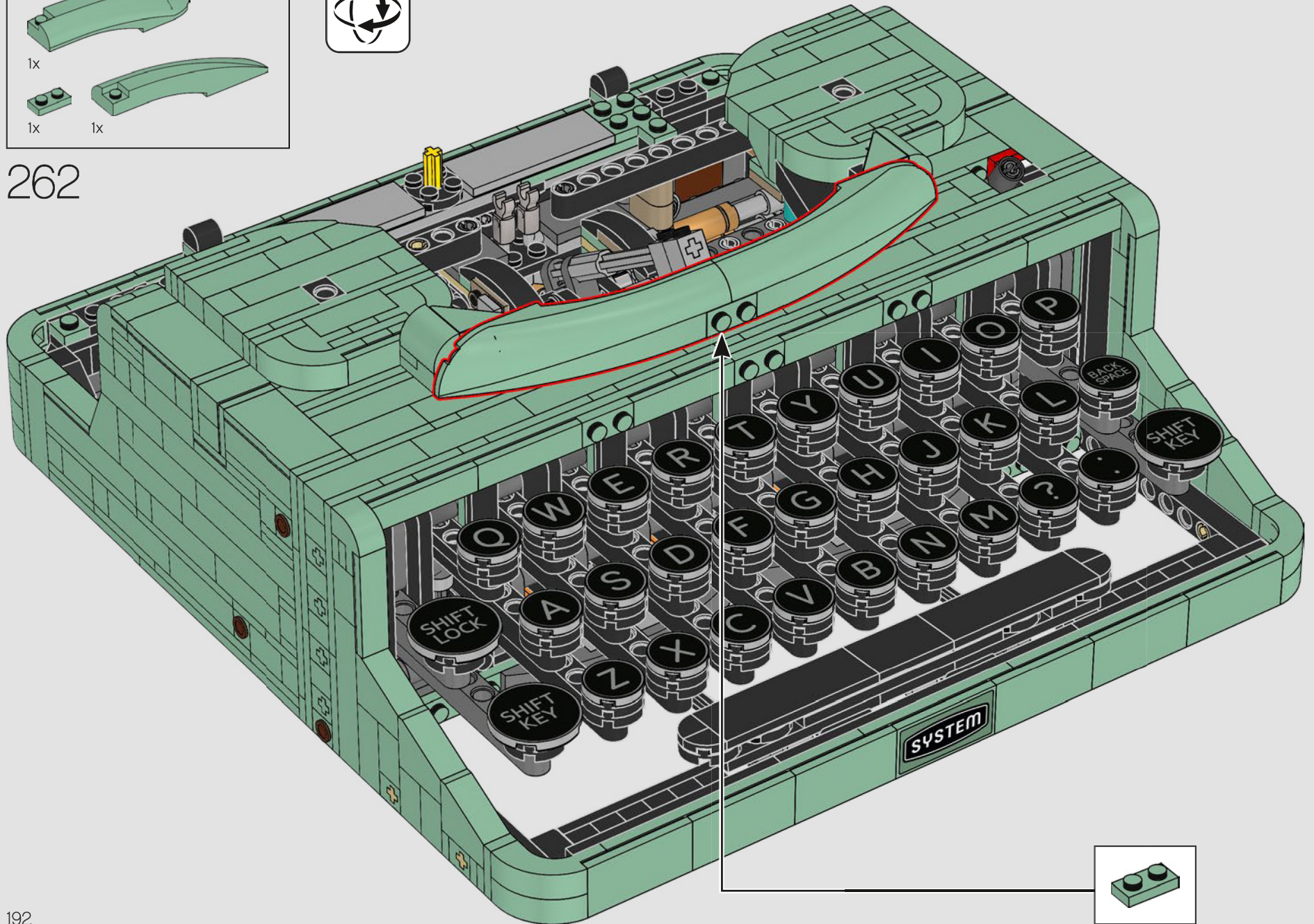

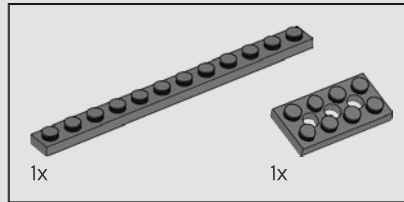
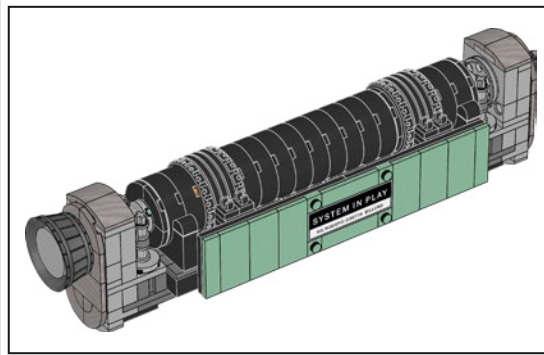
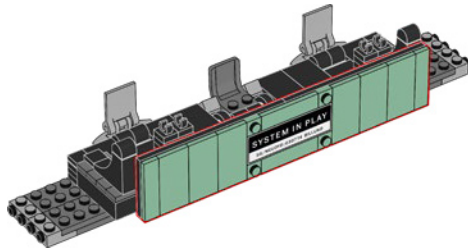

263

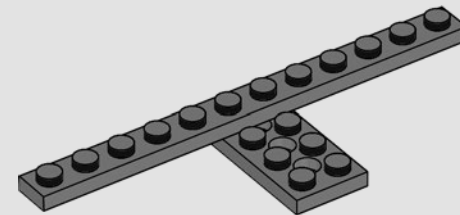

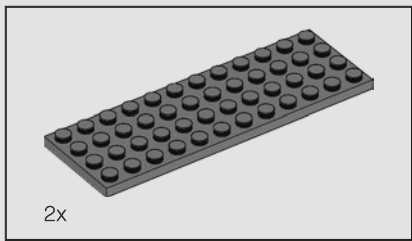

264

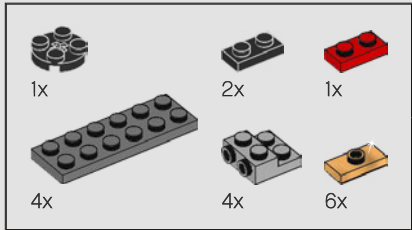
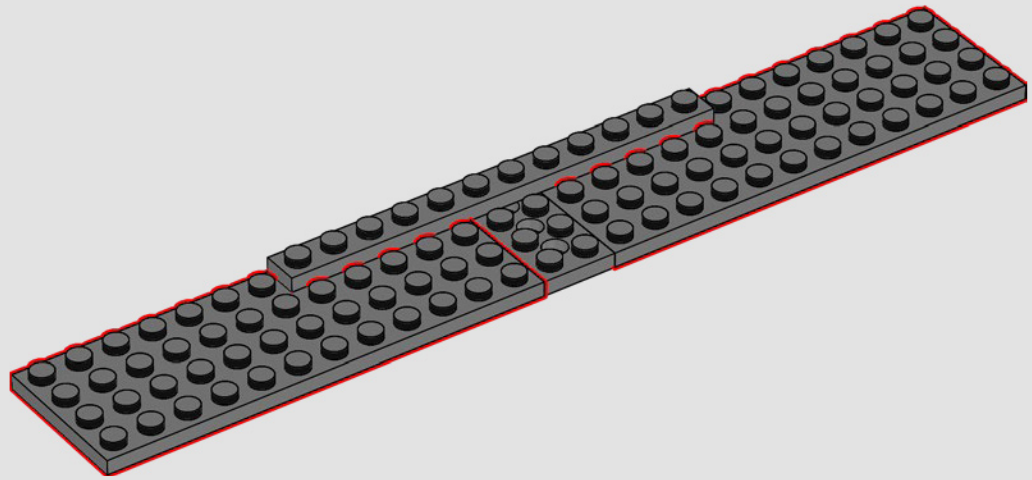

265

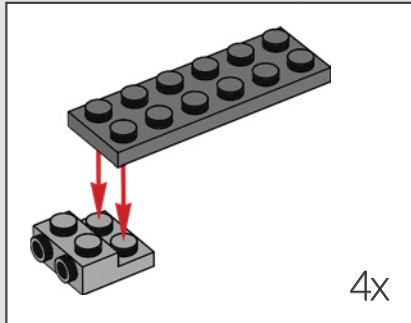
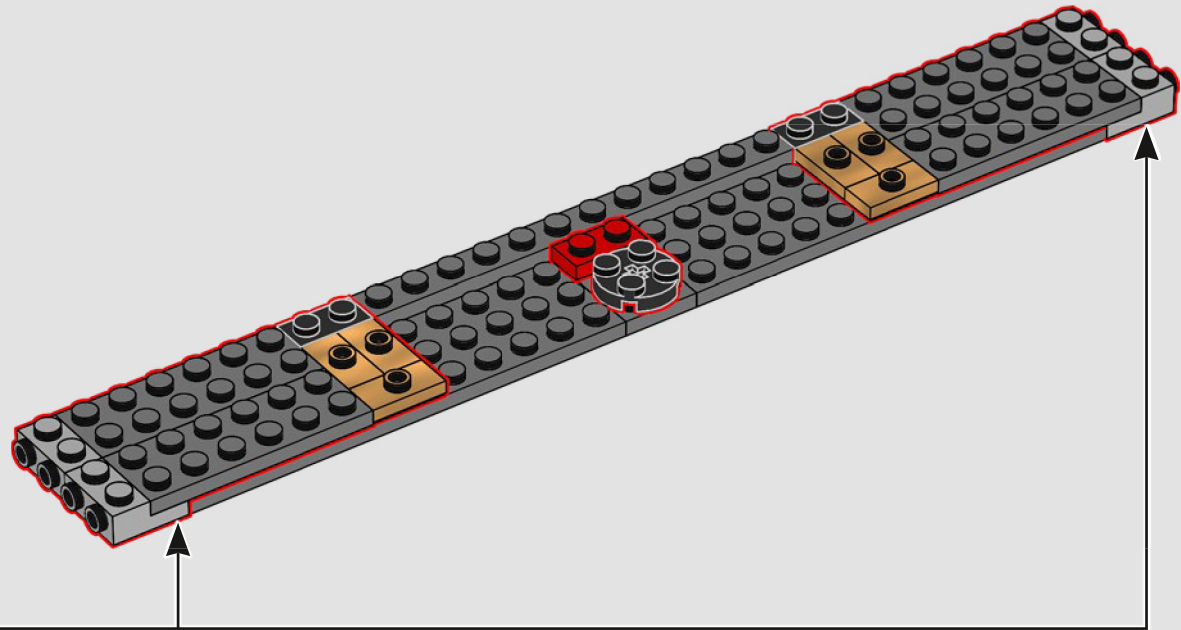

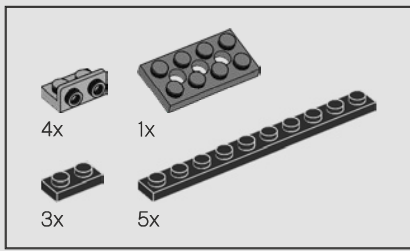

266

1

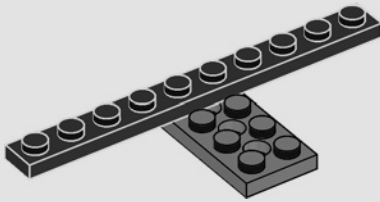

2

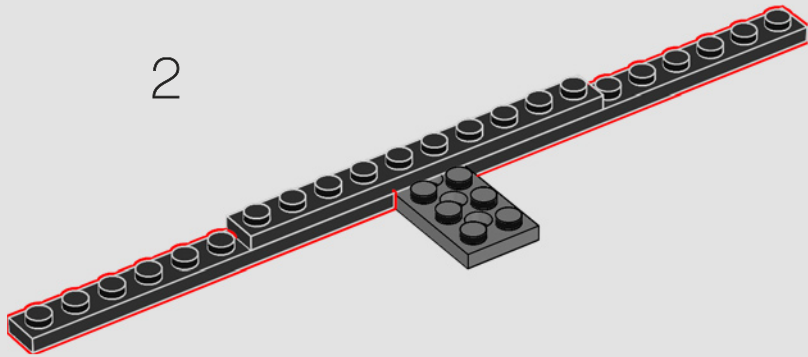

3

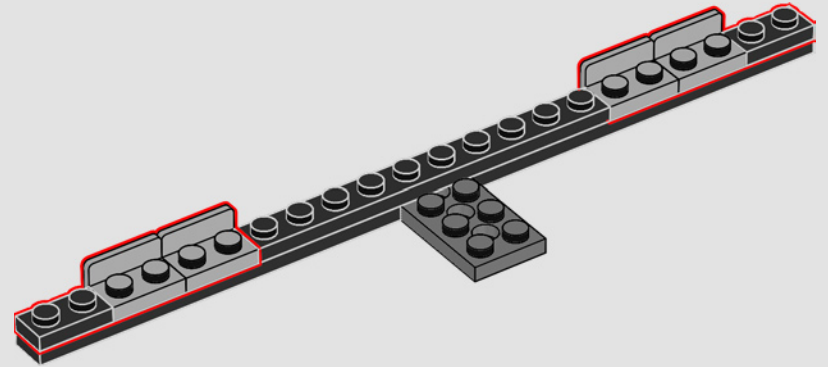

4

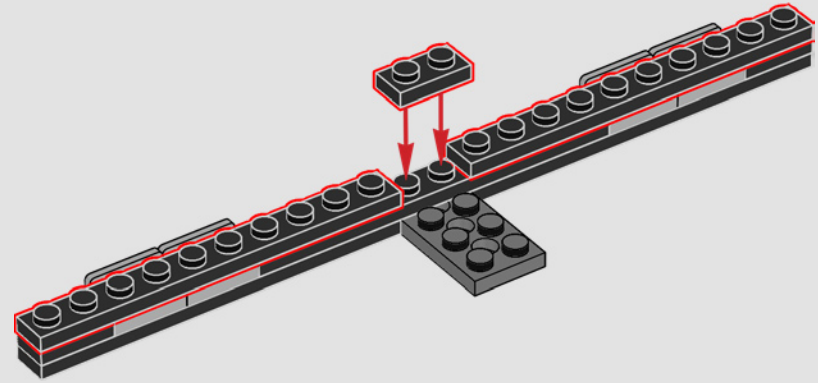

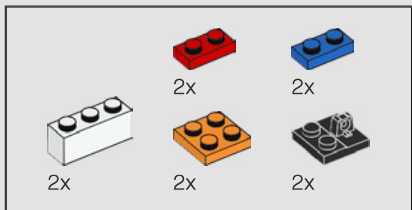
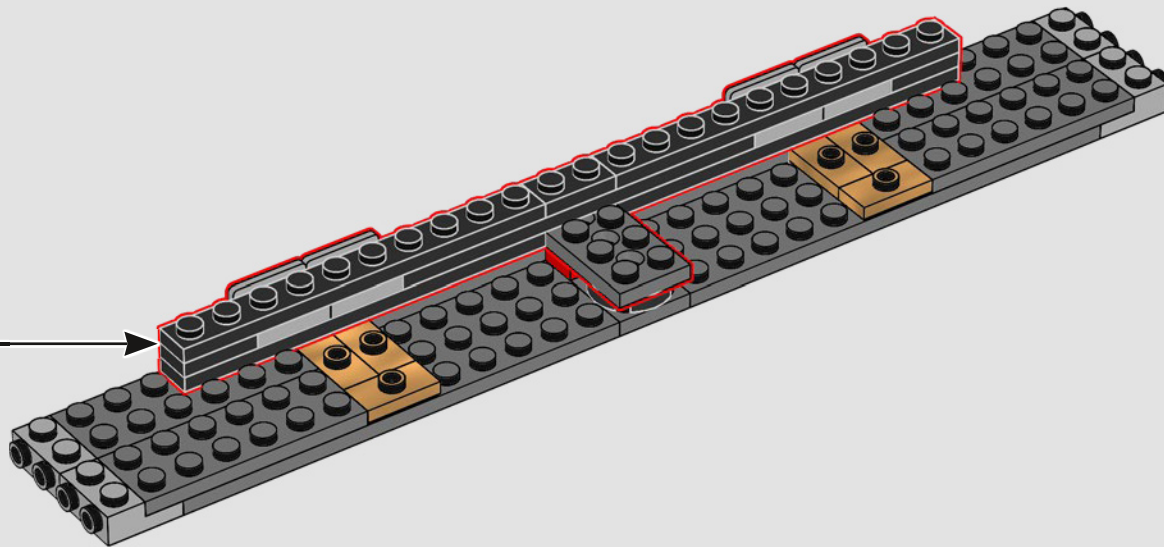

267

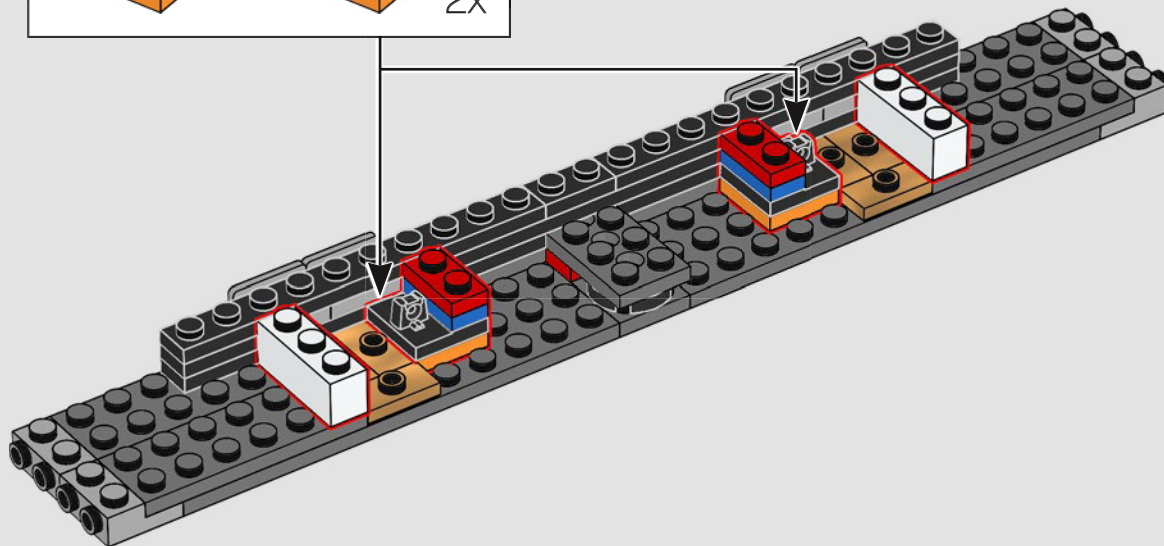
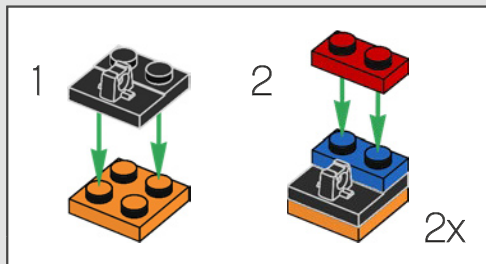

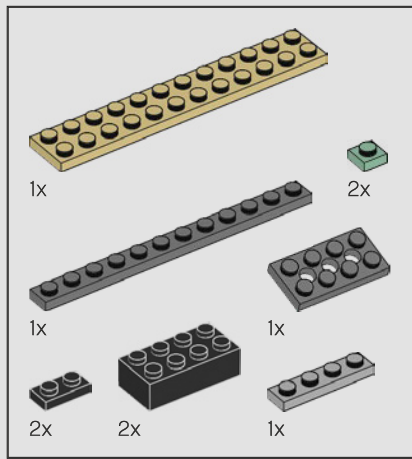

268

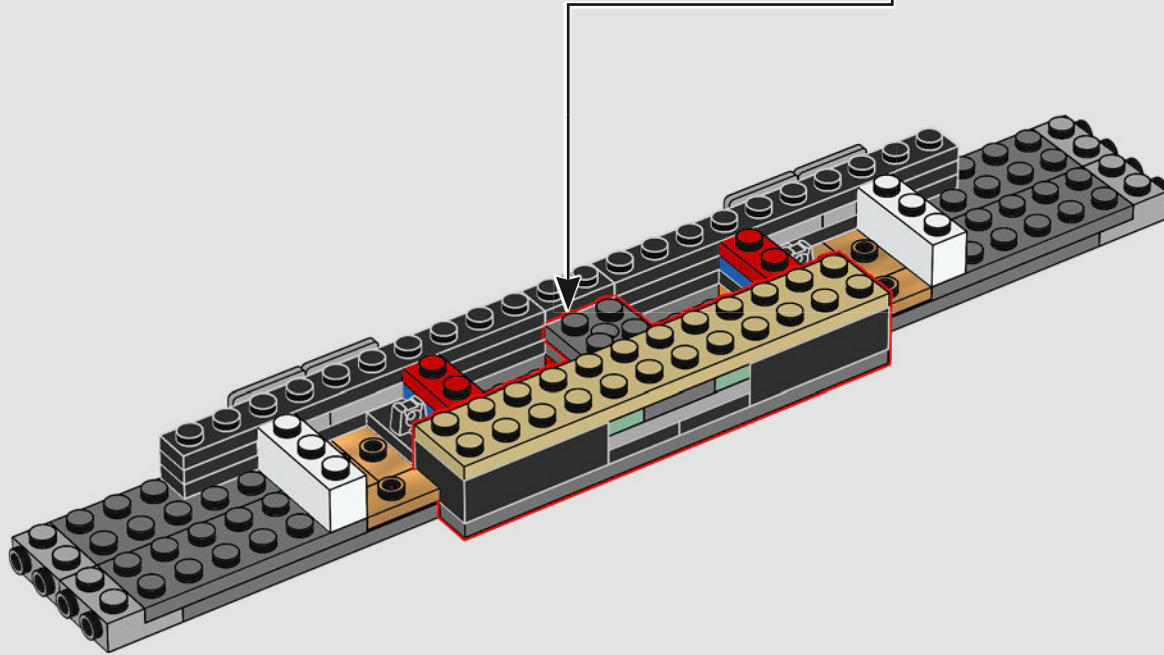
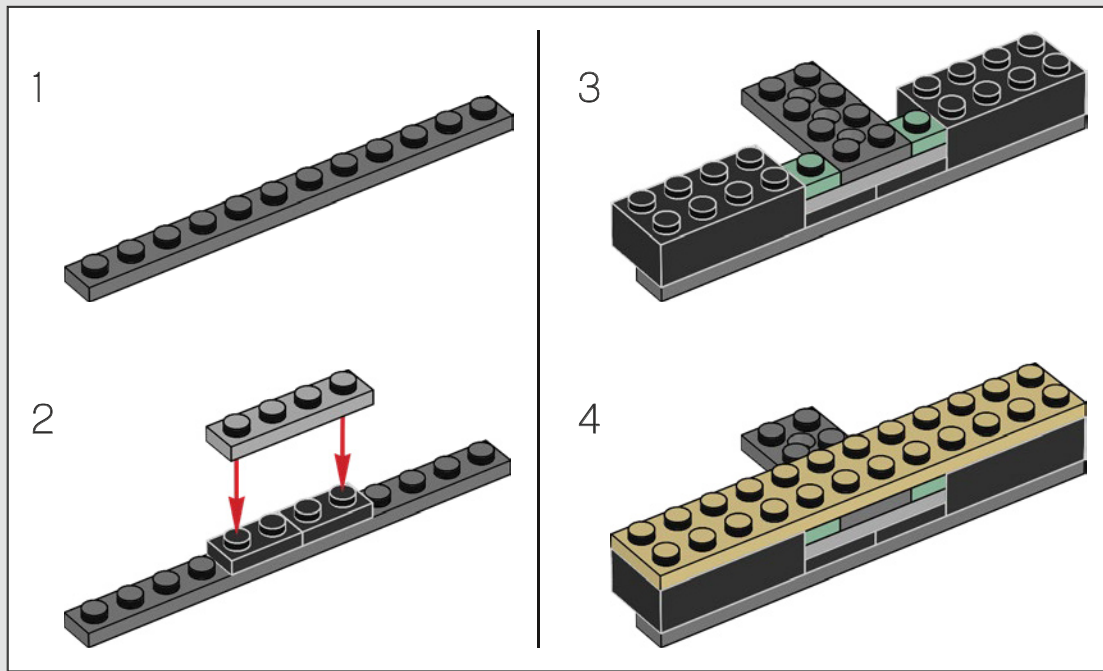

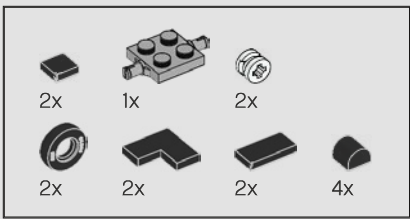

269

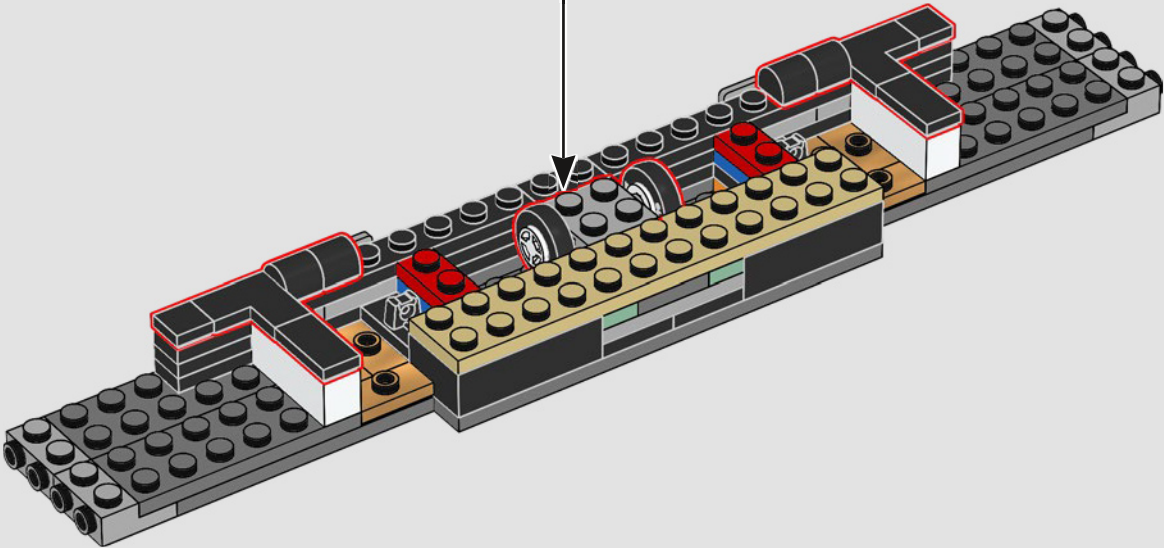
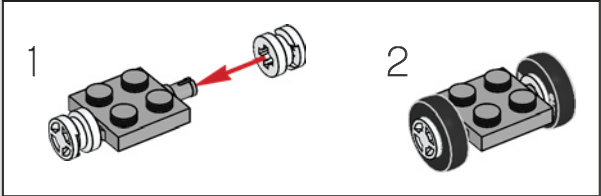

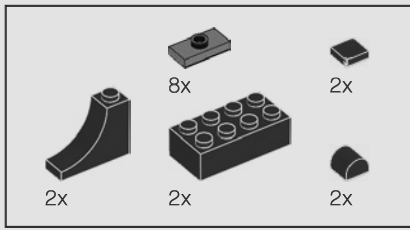

270

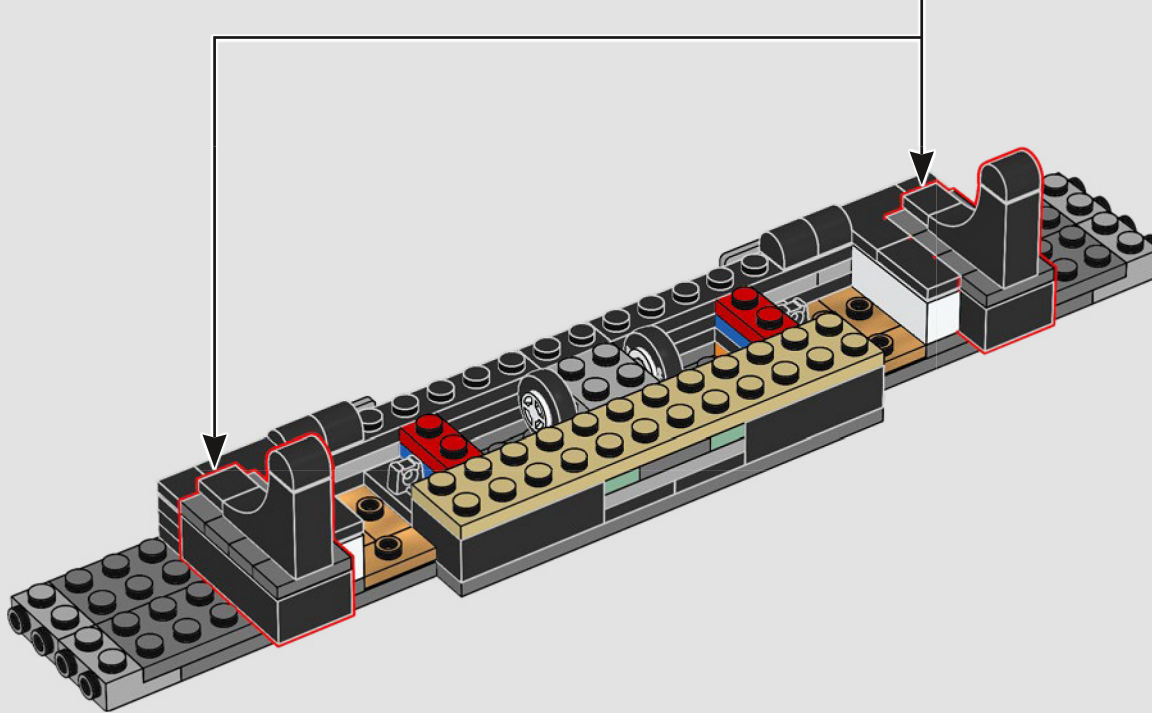
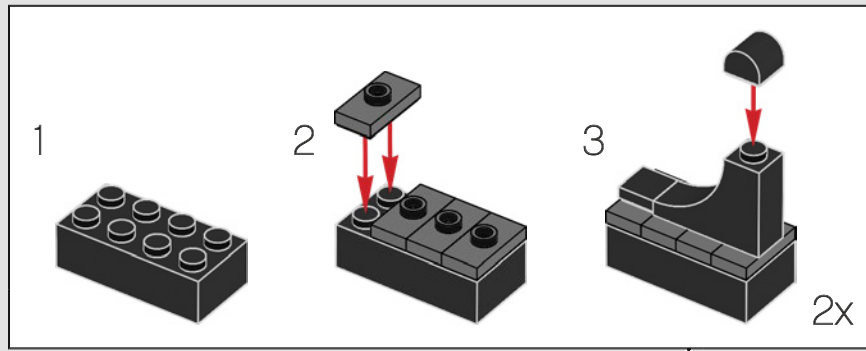

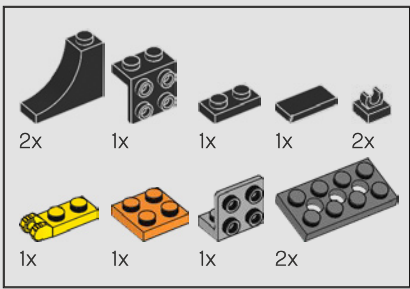

271

1

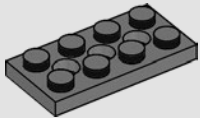

2

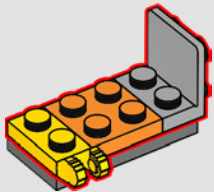

3



4

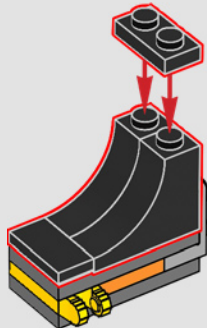

5

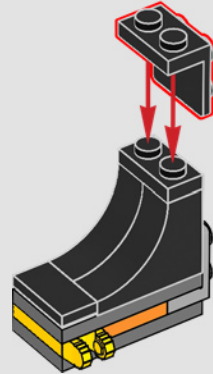

6

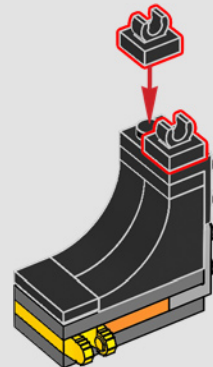

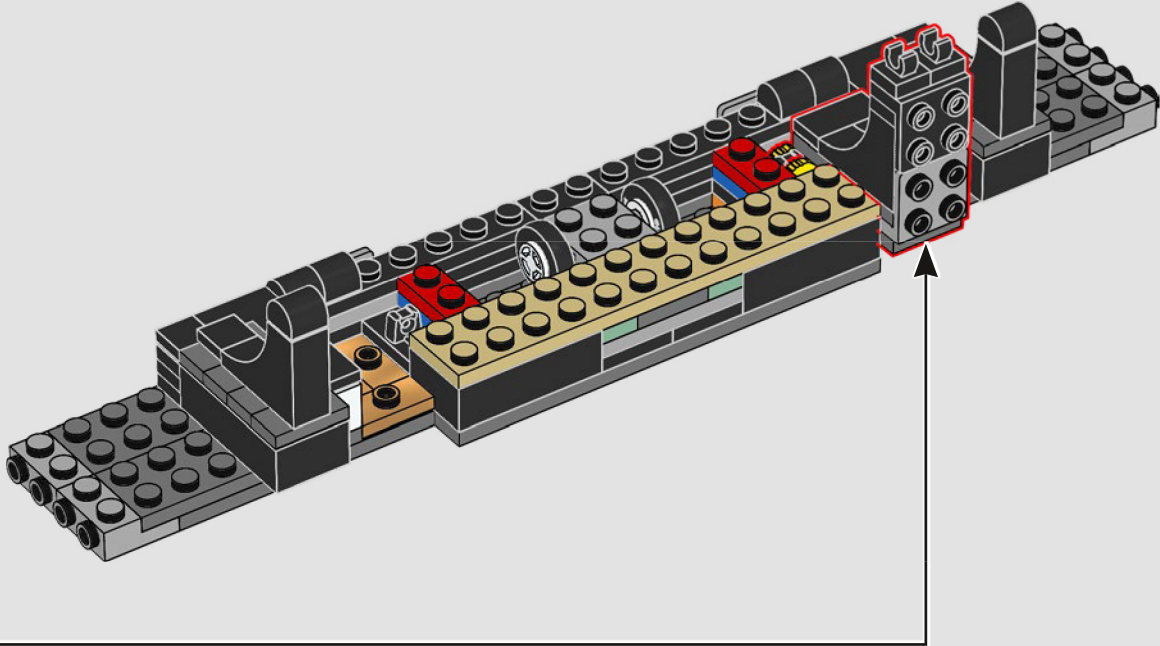

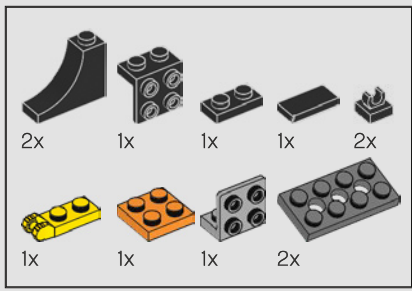

272

1

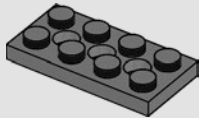

2

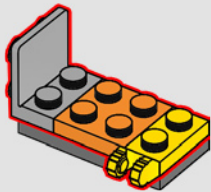

3

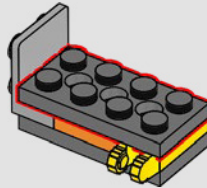

4

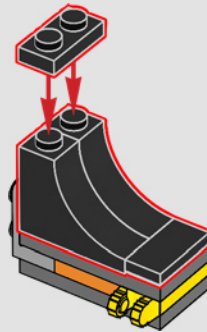

5

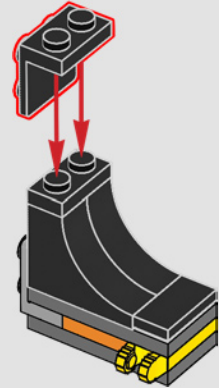

6

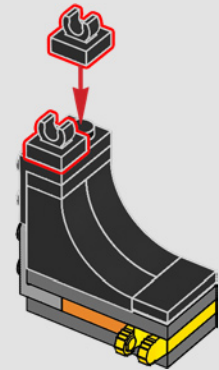

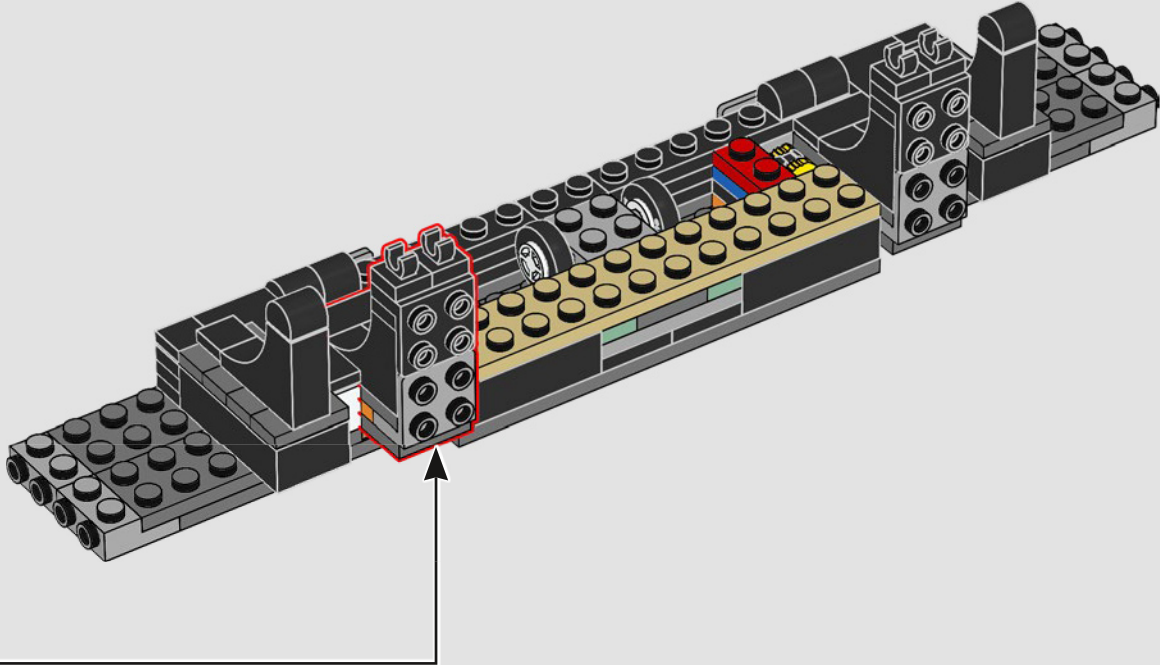

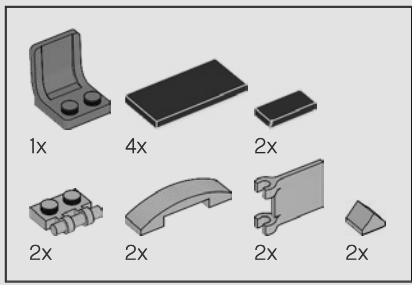

273

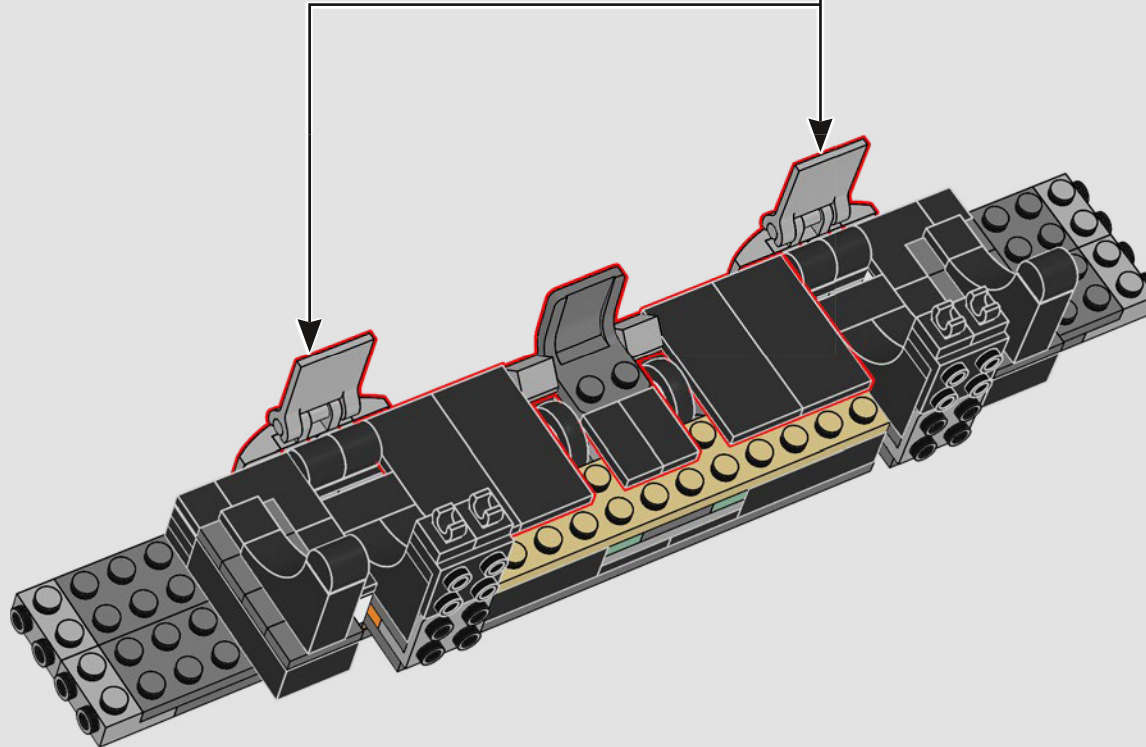
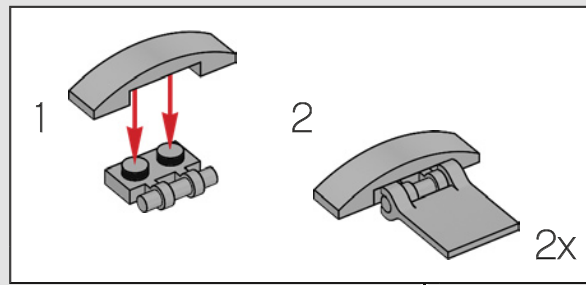

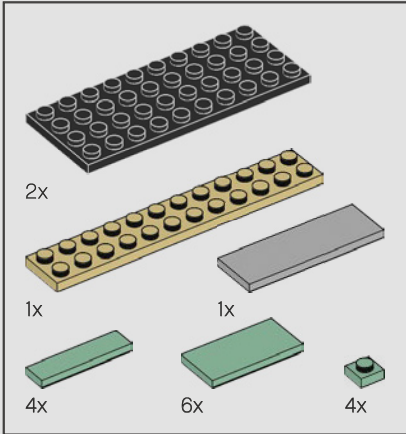
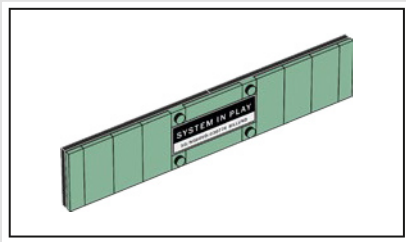

274

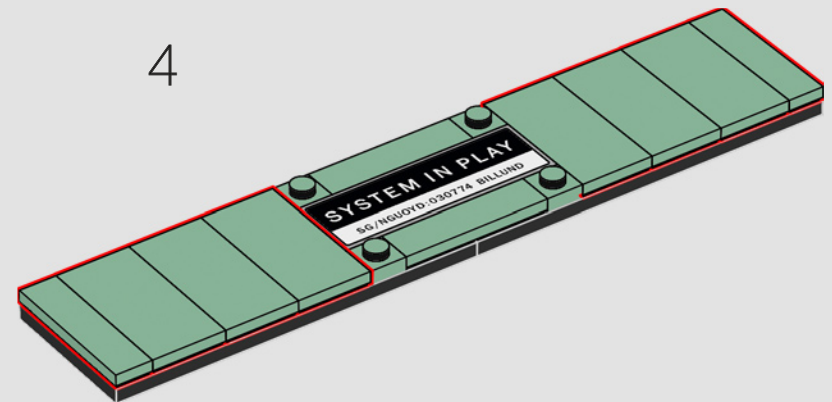
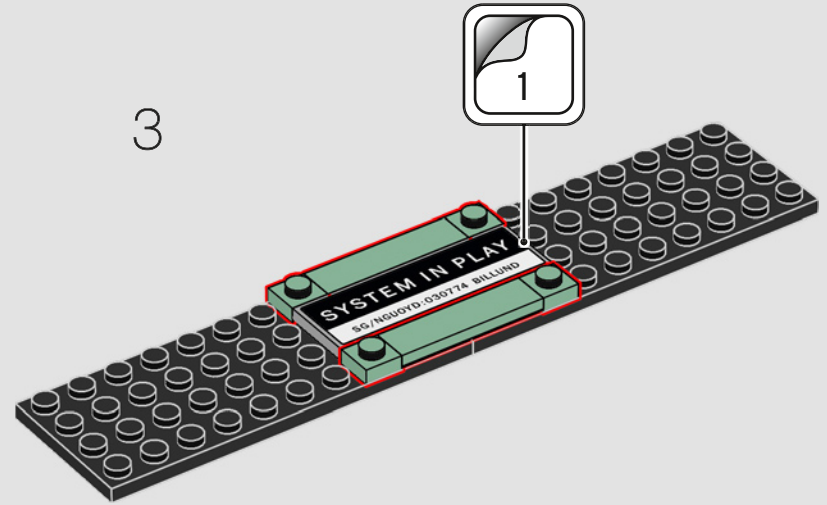
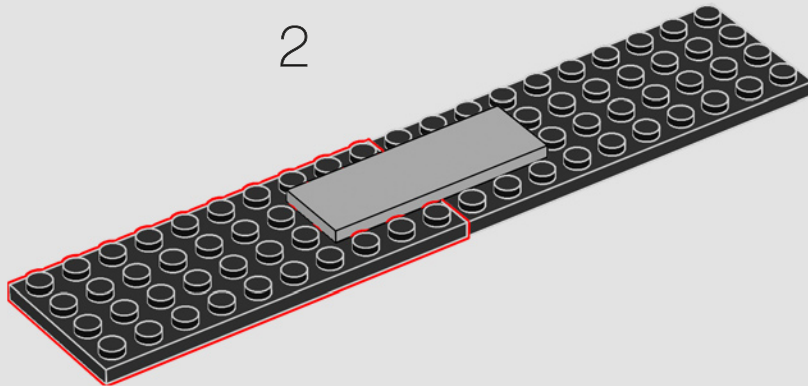
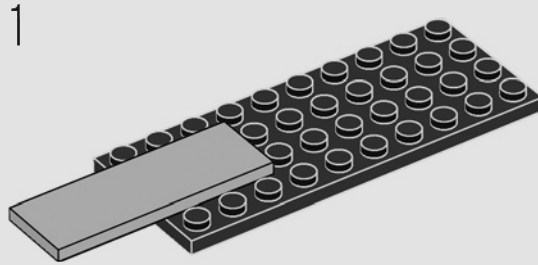

5

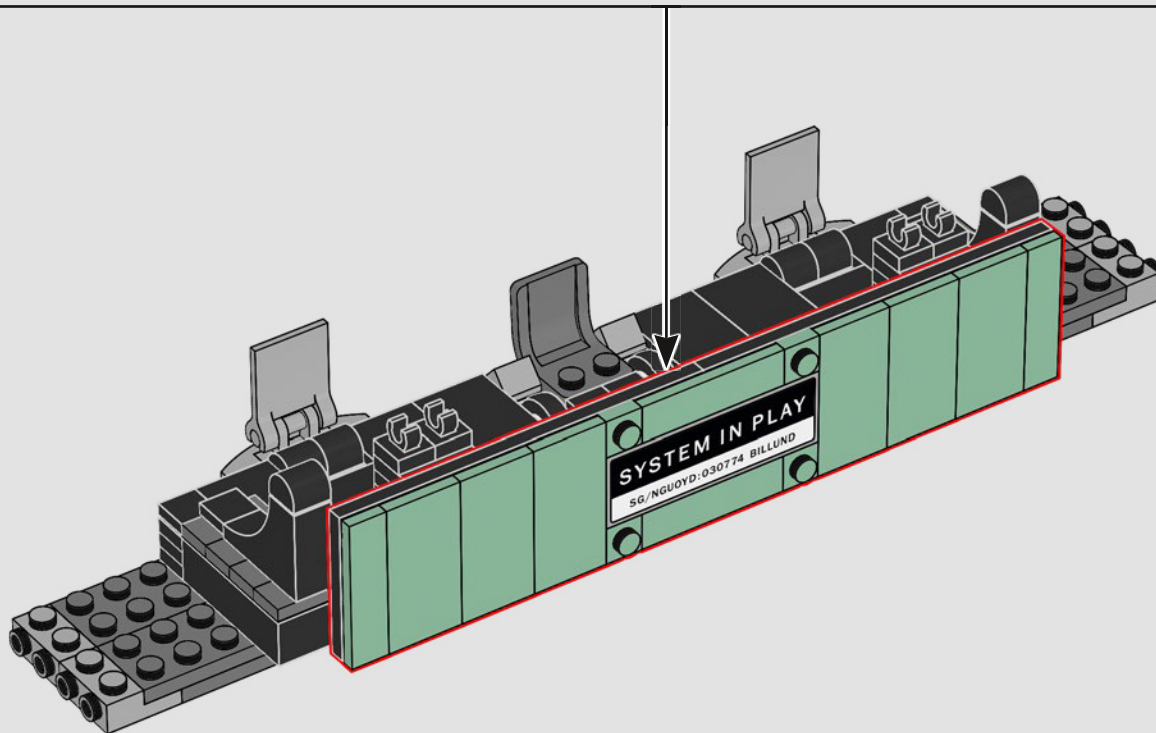
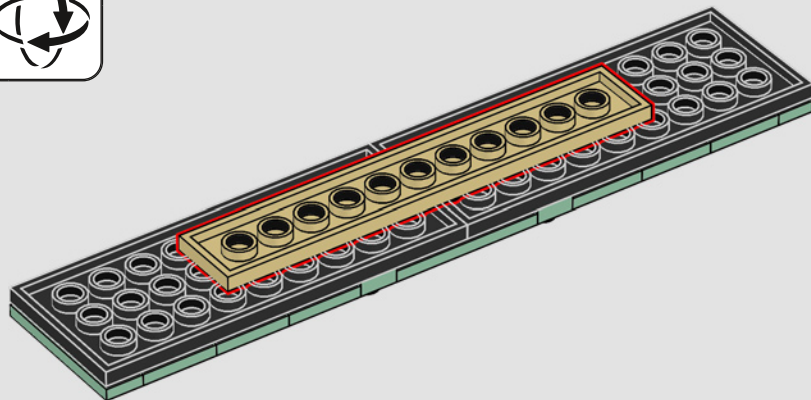

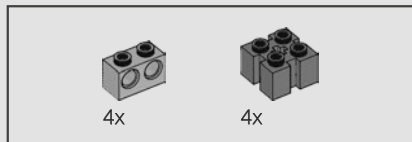
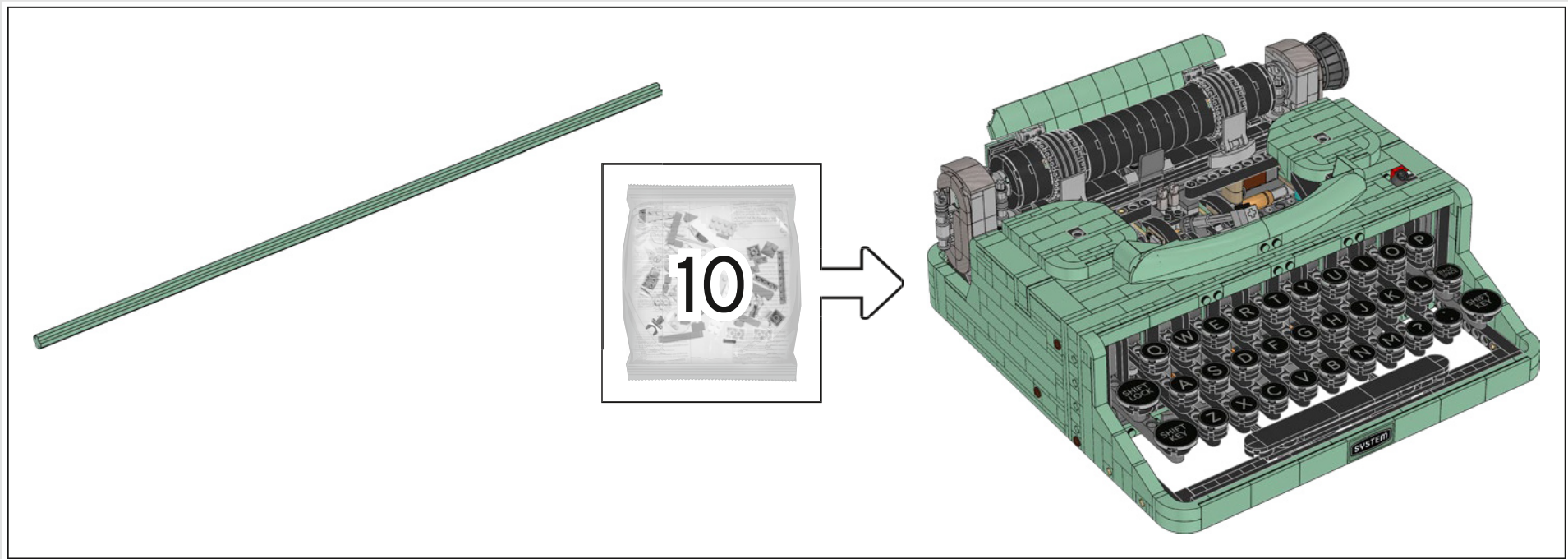

275

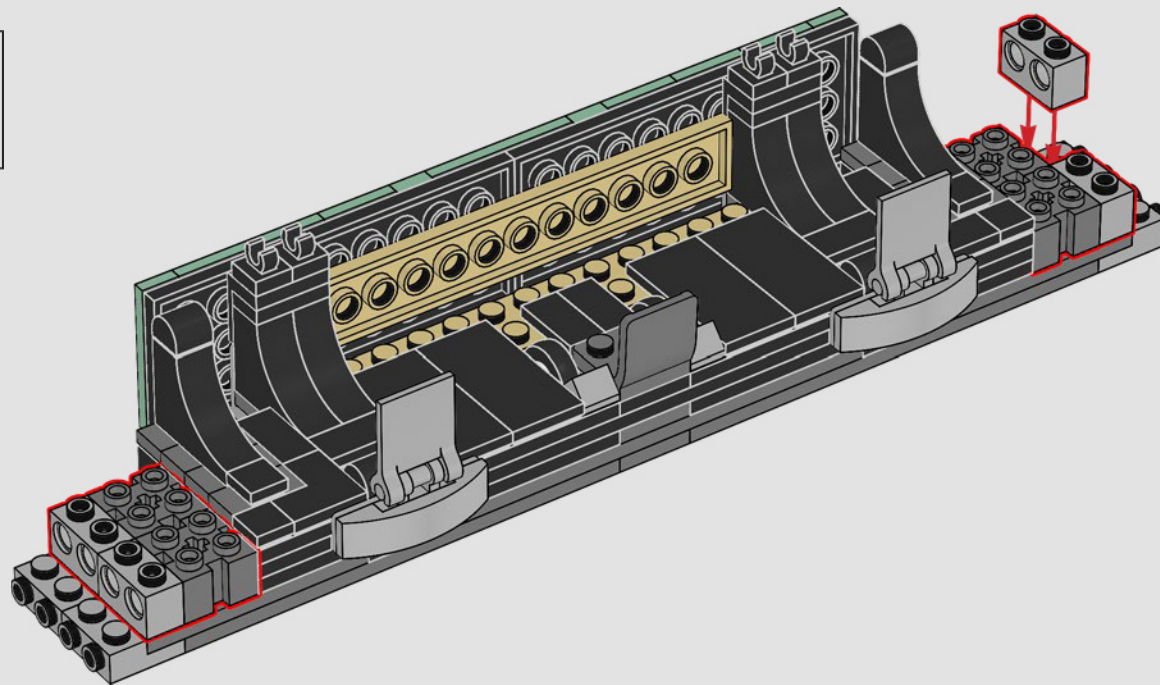

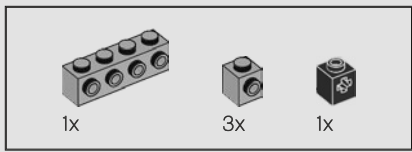

276

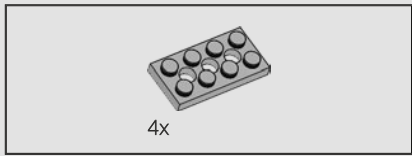
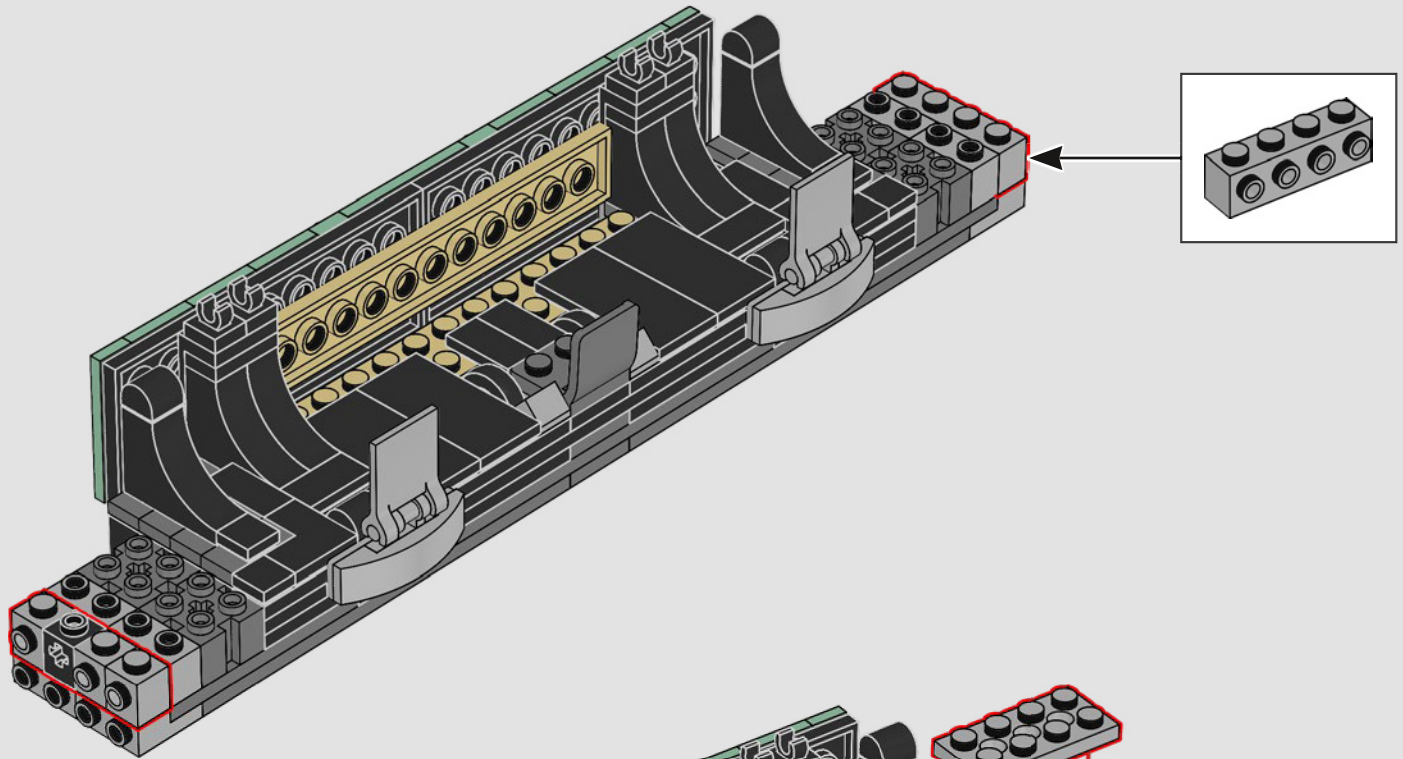

277

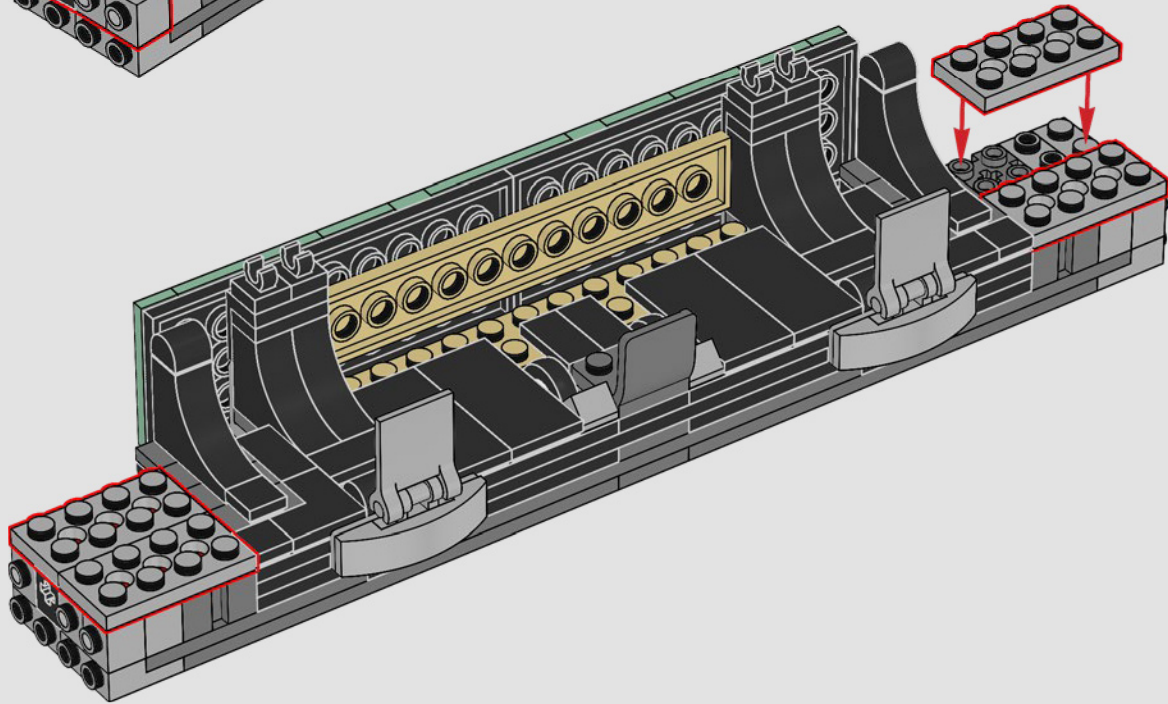

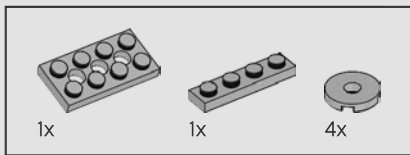

278

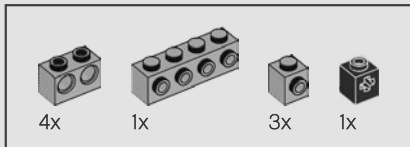
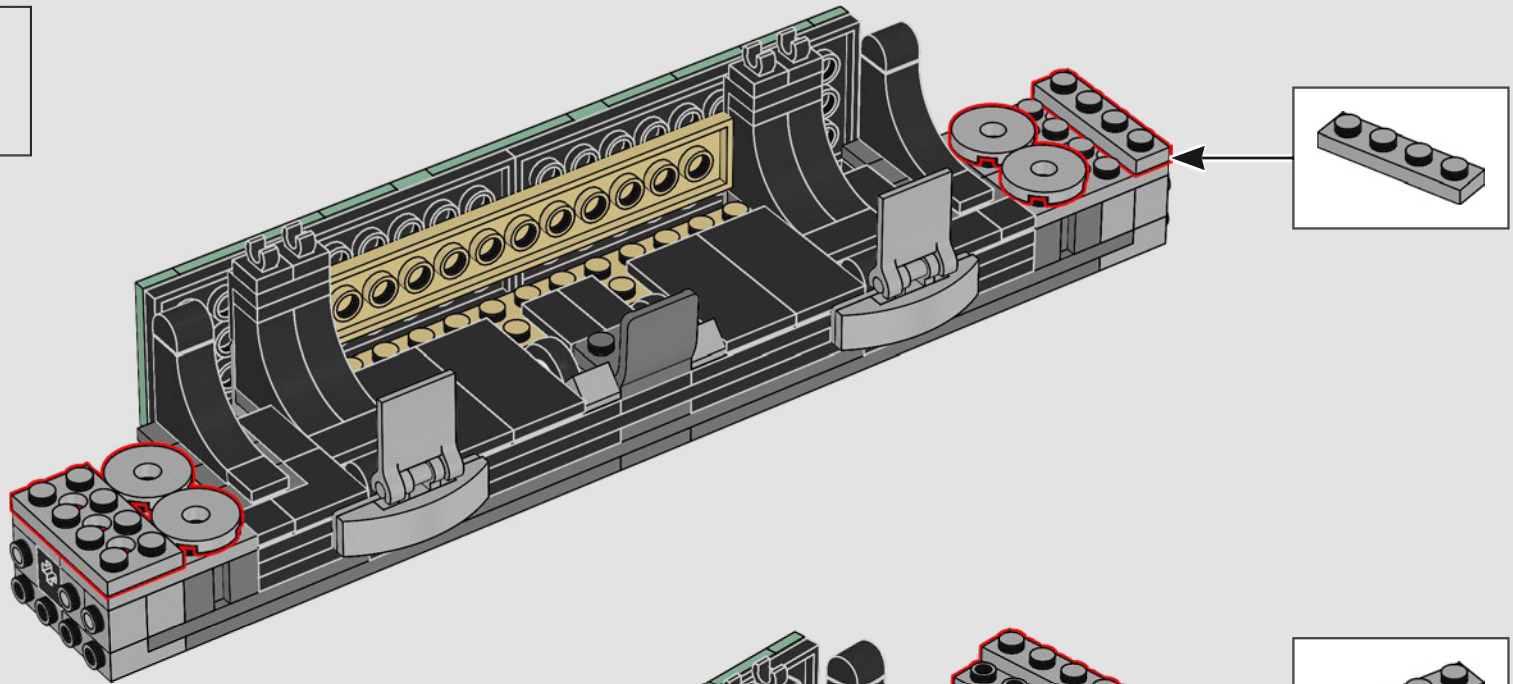

279

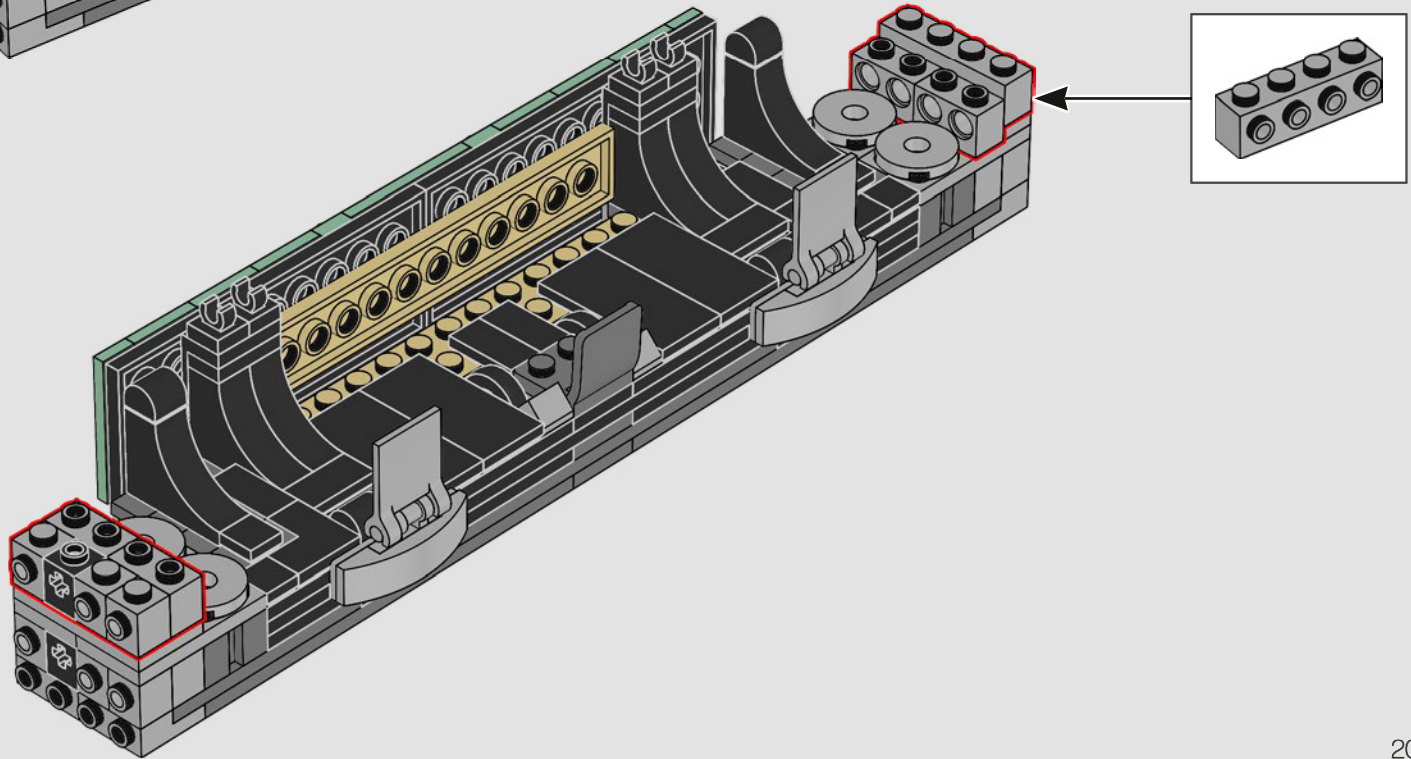

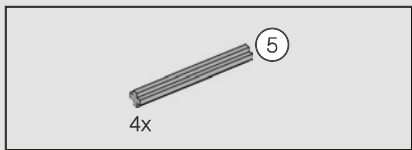

280

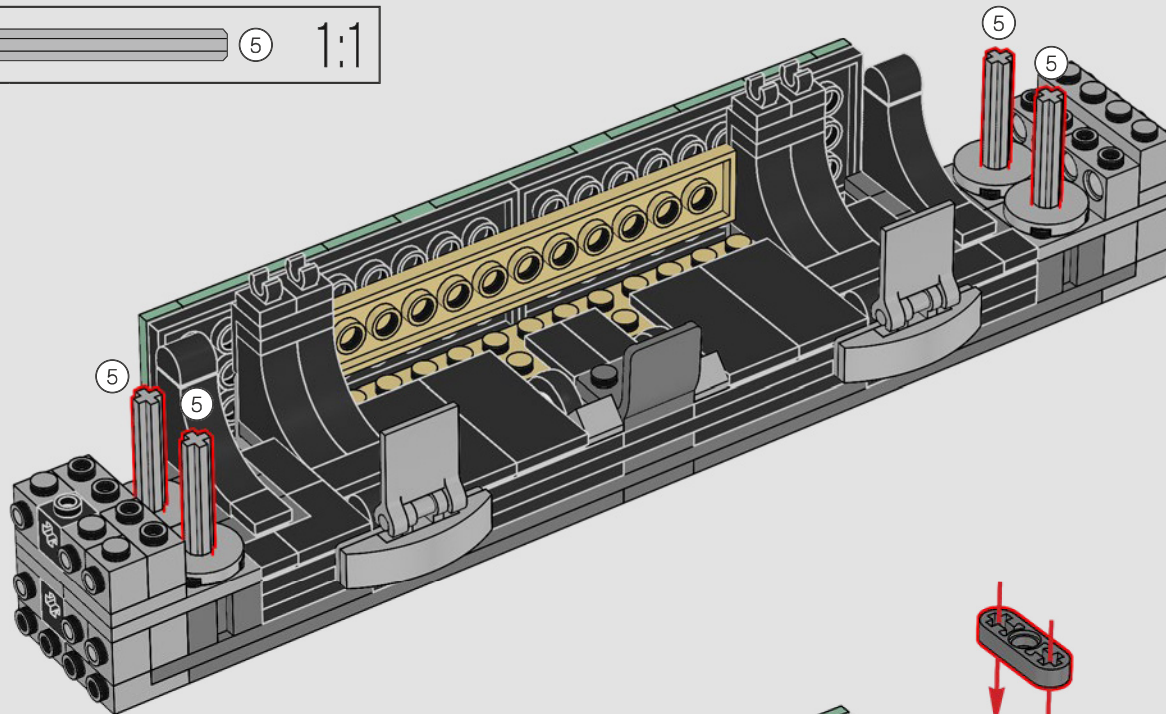
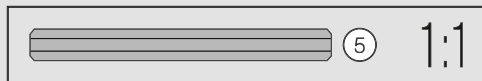

281

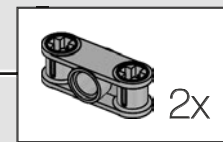
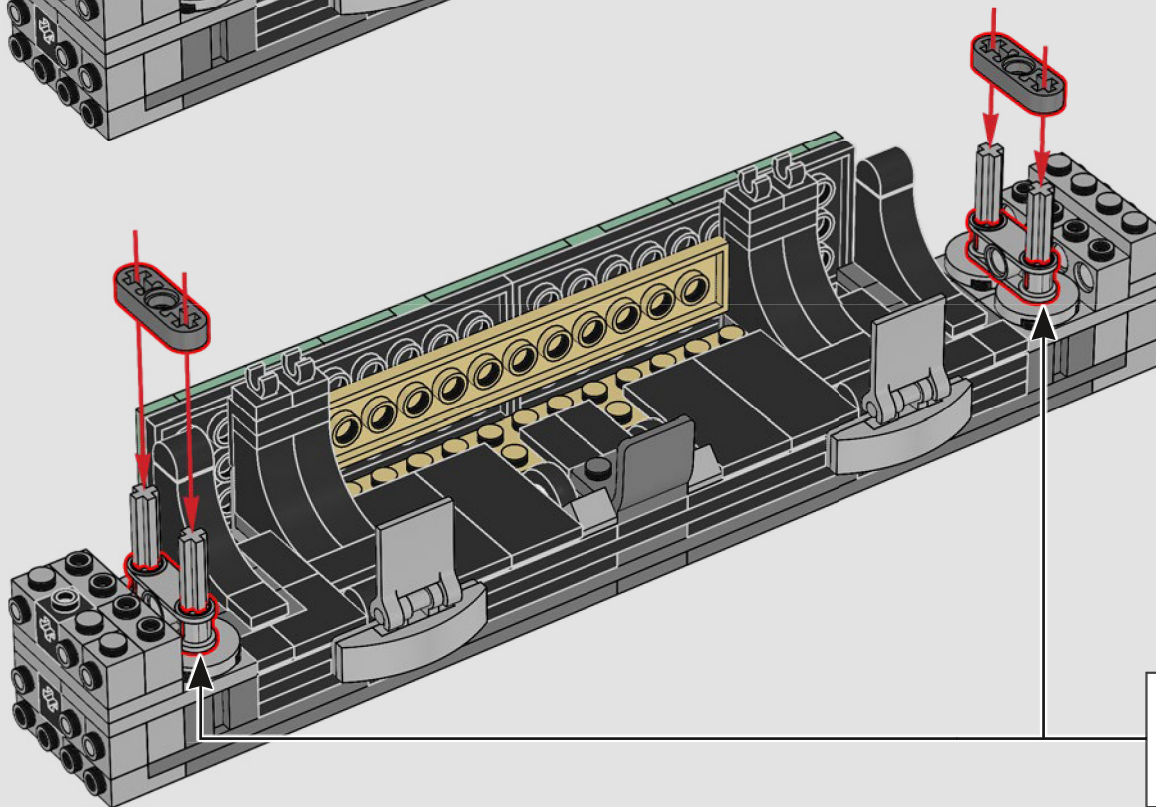

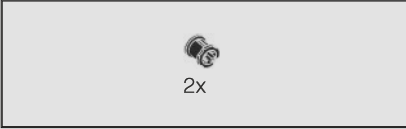
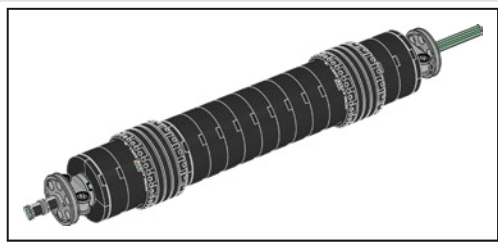

282

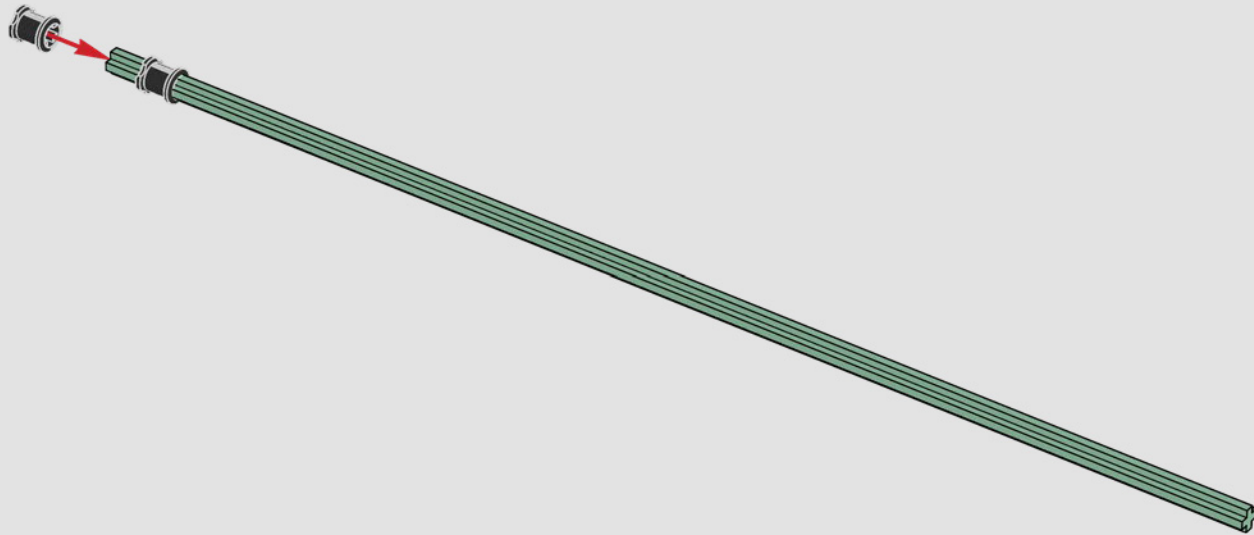

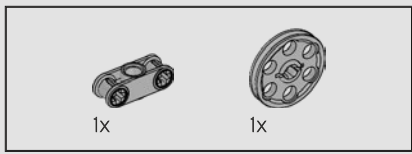

283

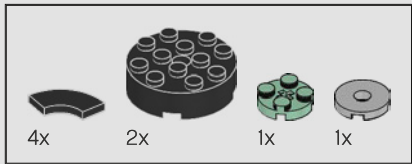
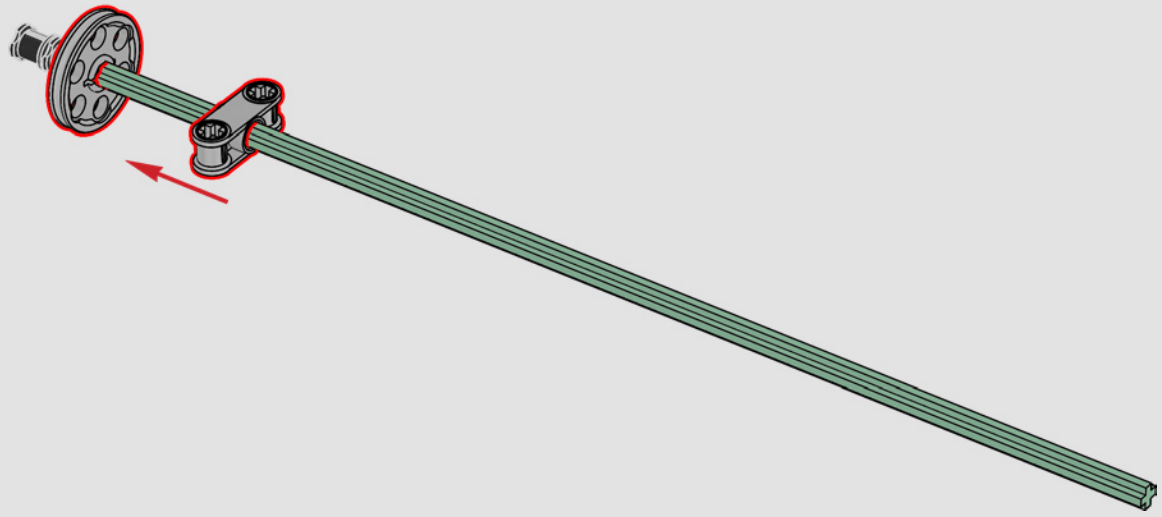

284

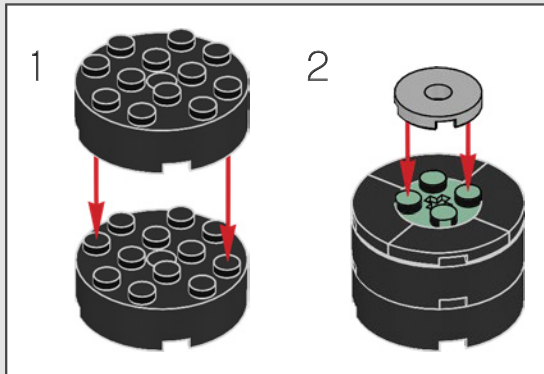
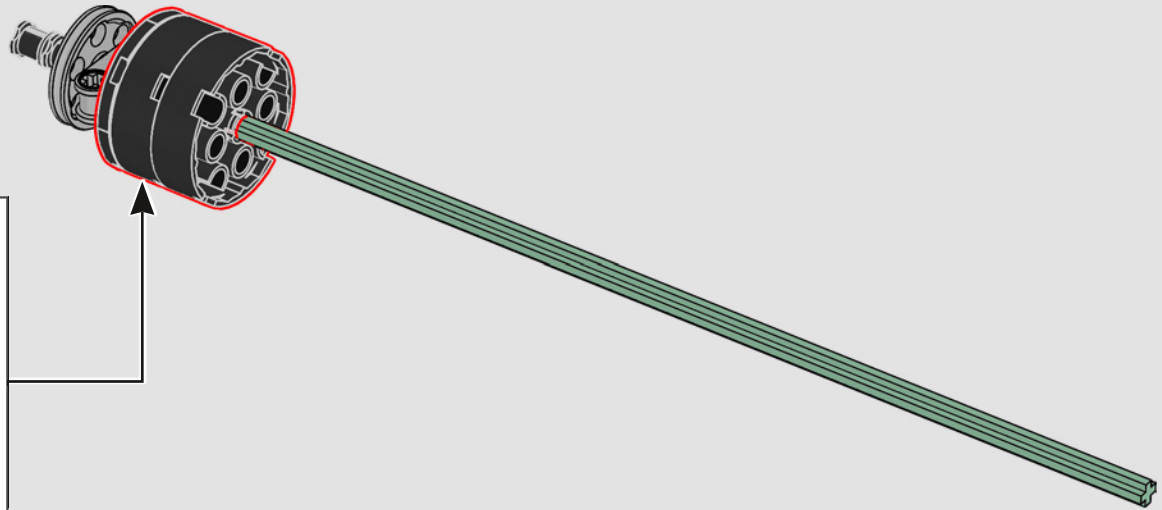

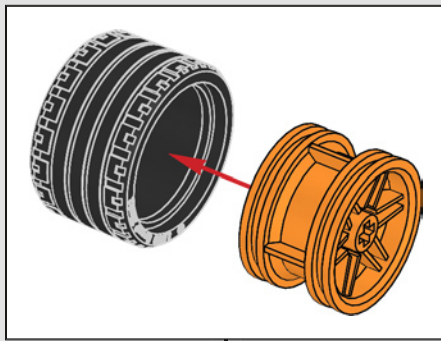
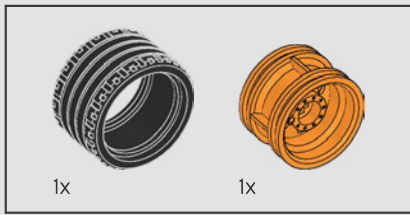

285

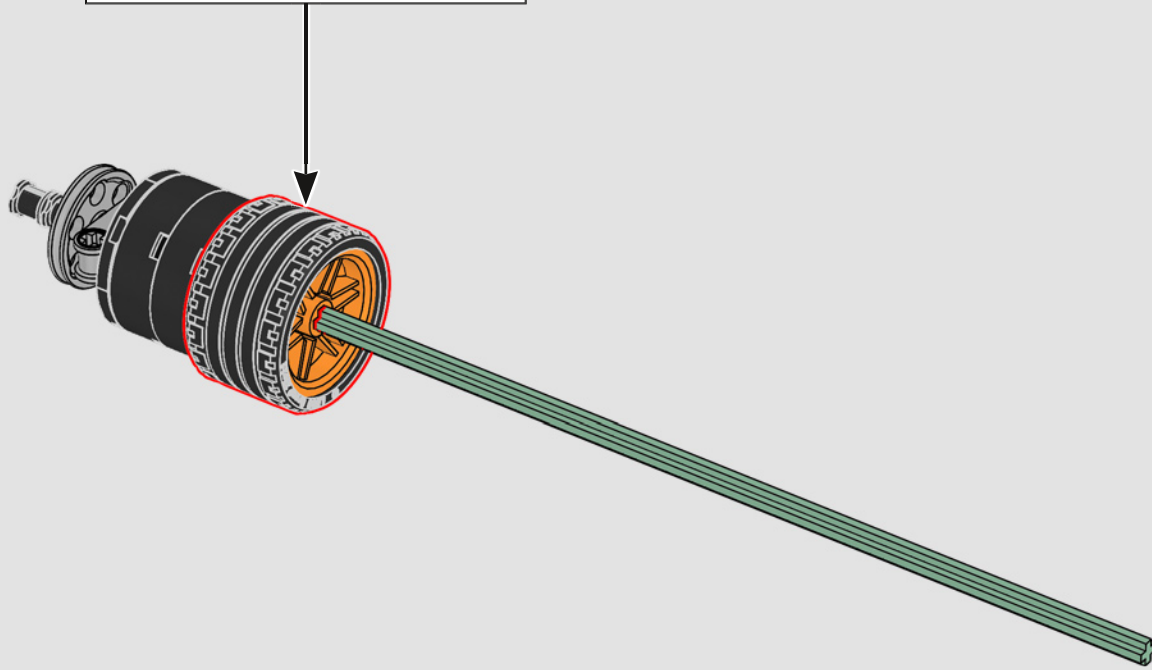

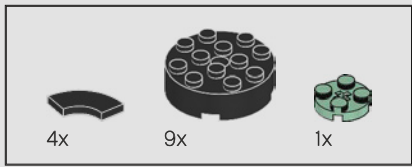

286

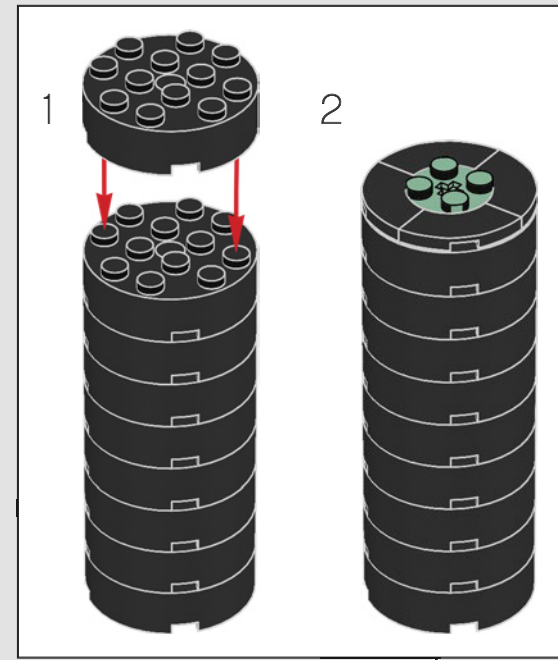
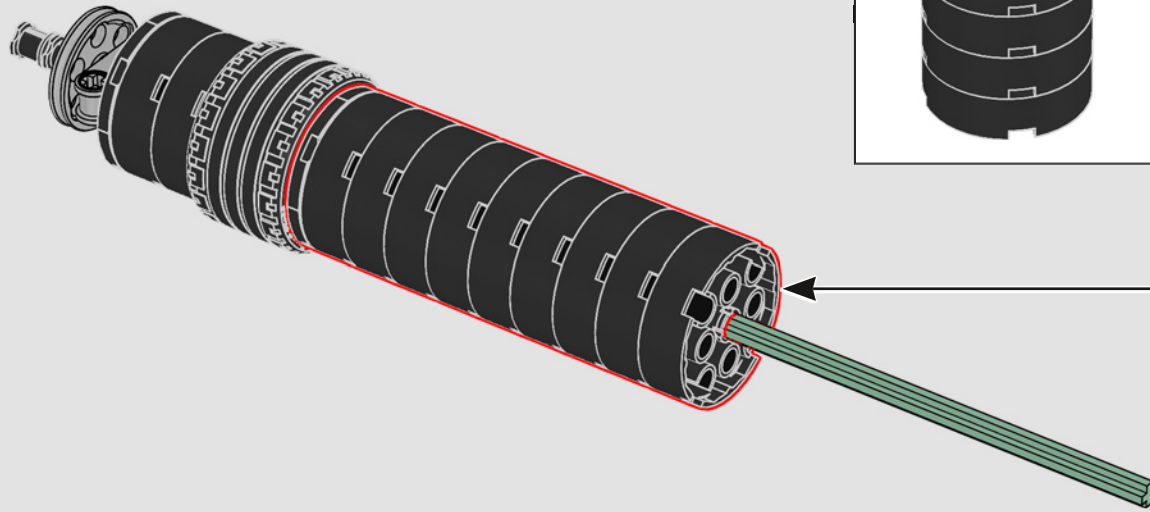

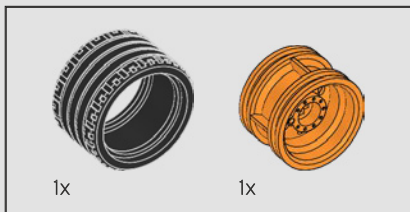

287

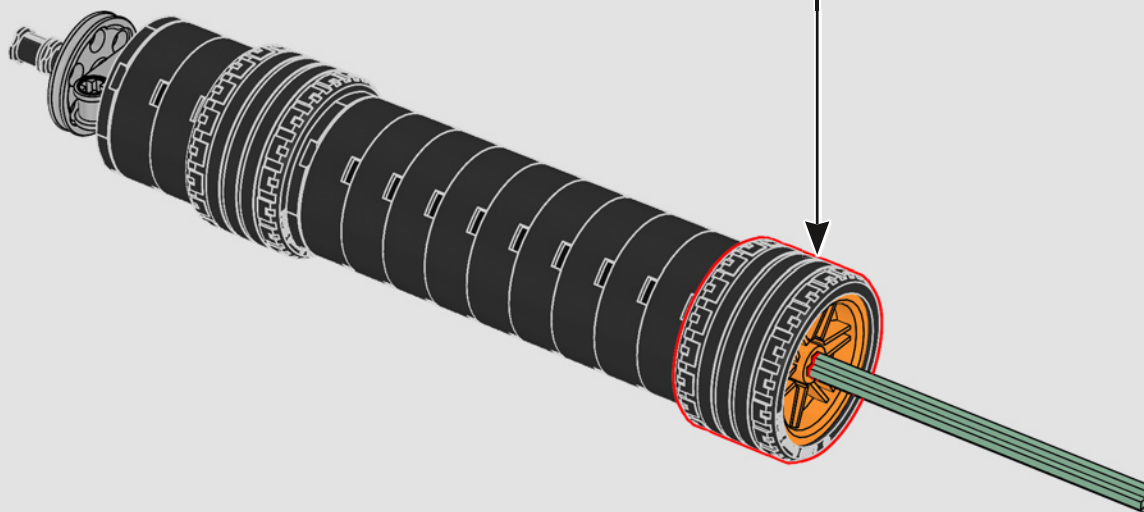
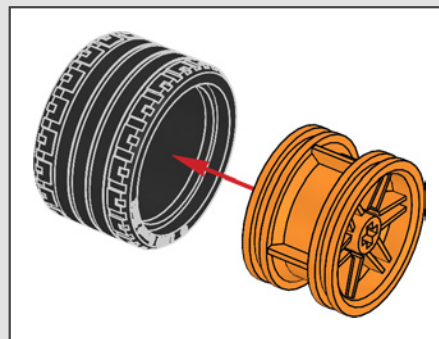

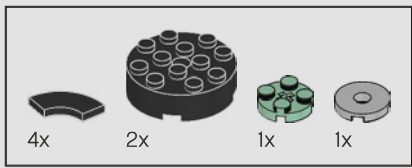

288

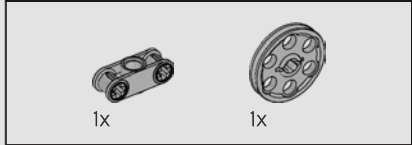
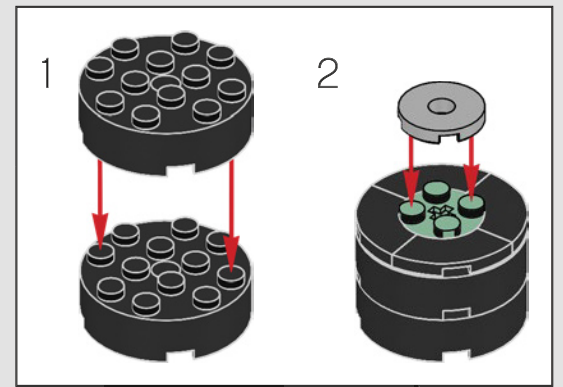
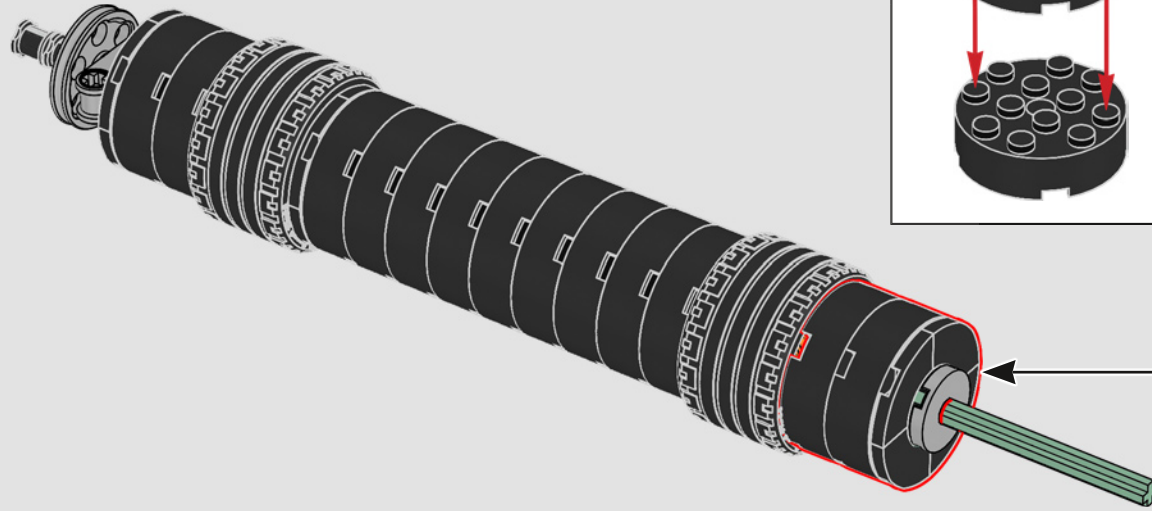

289

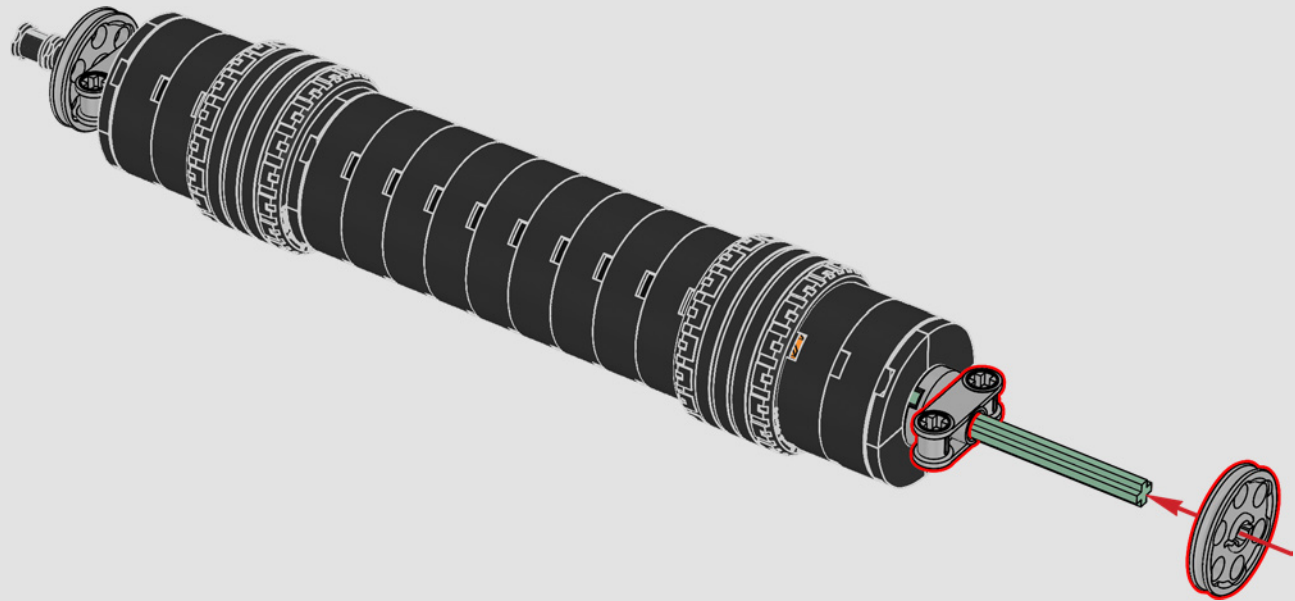

290

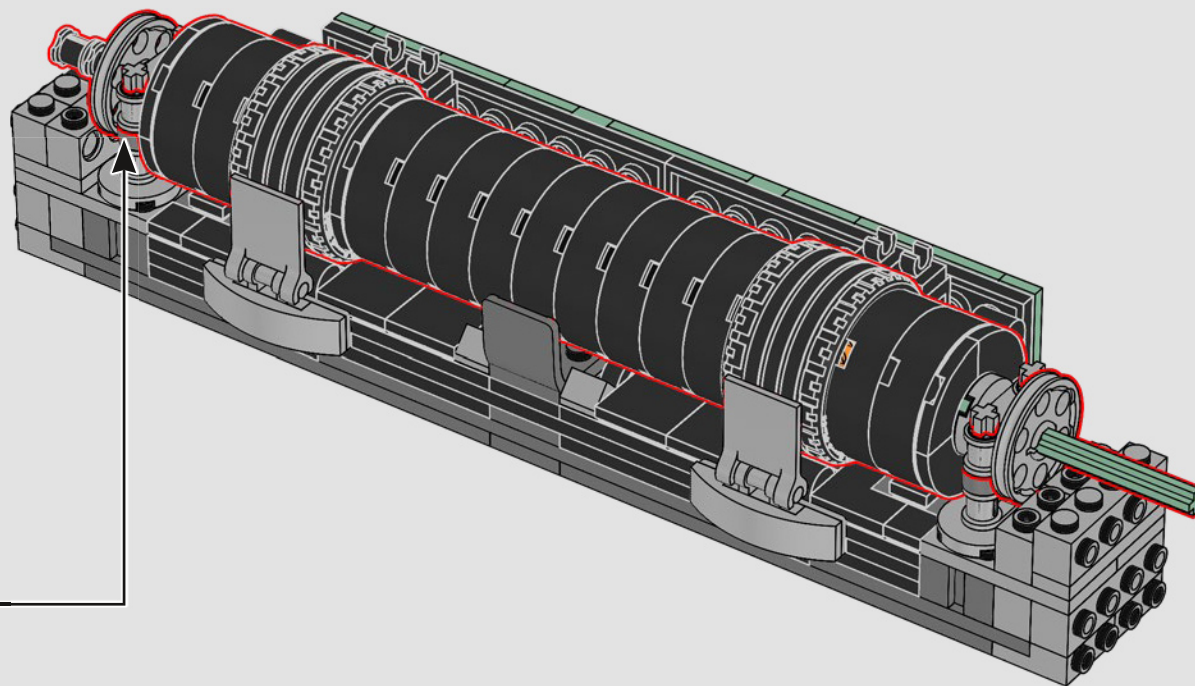

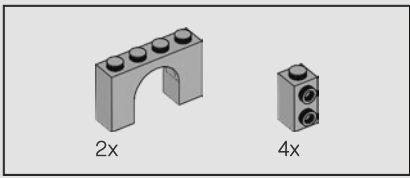

291

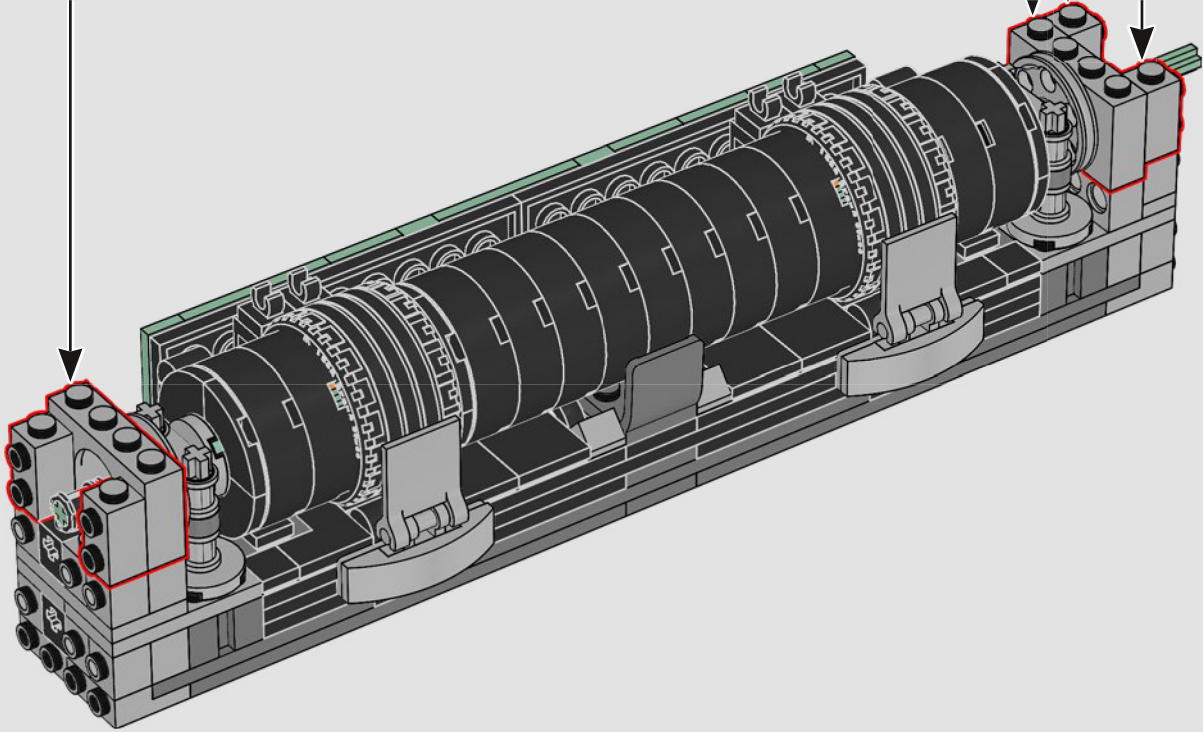
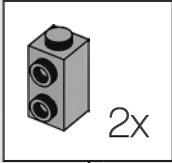
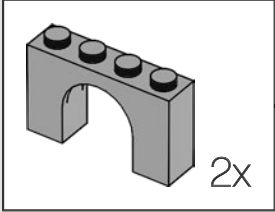

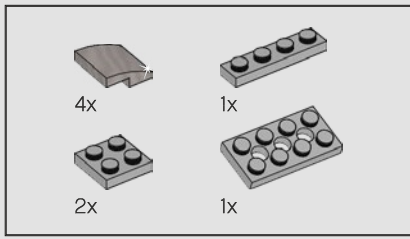

292

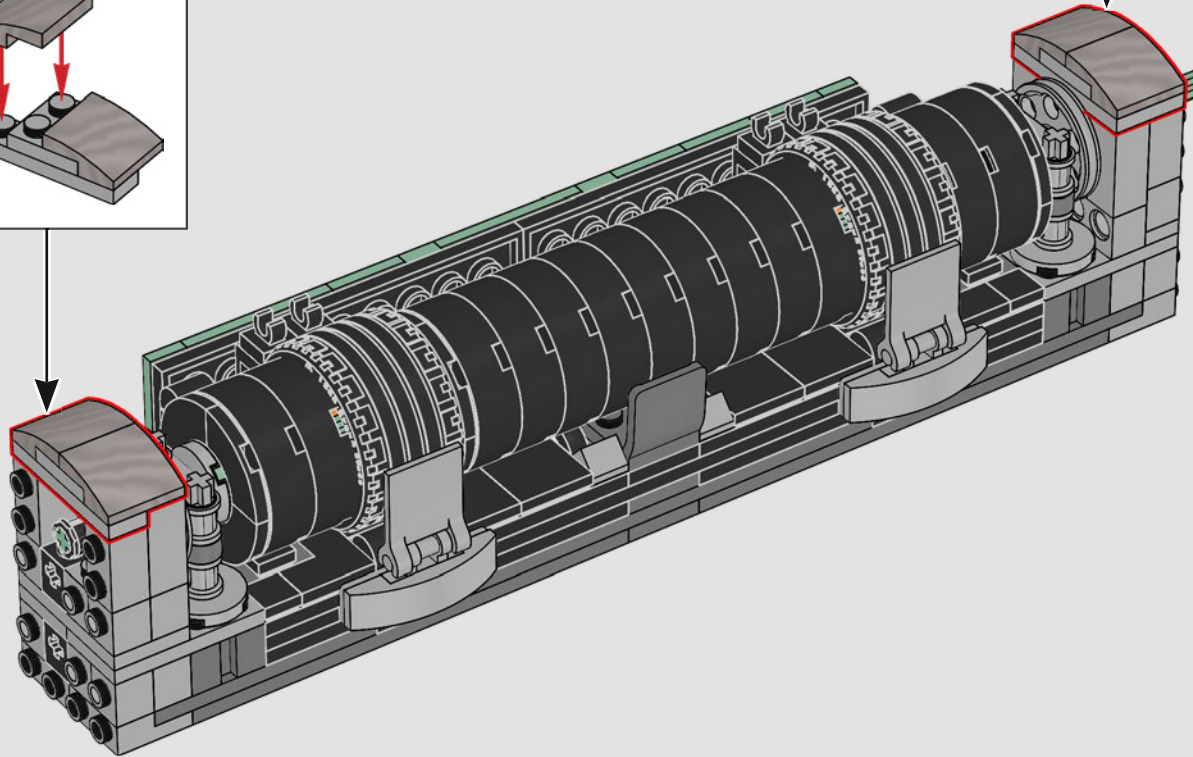
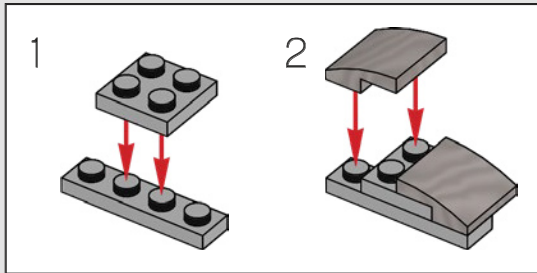
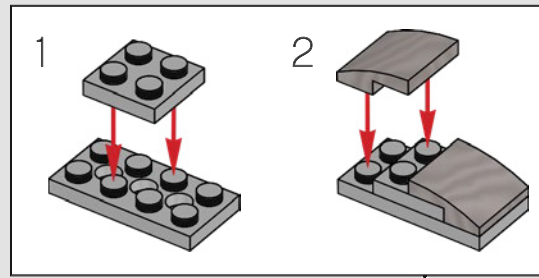

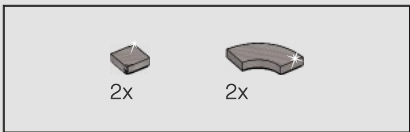

293

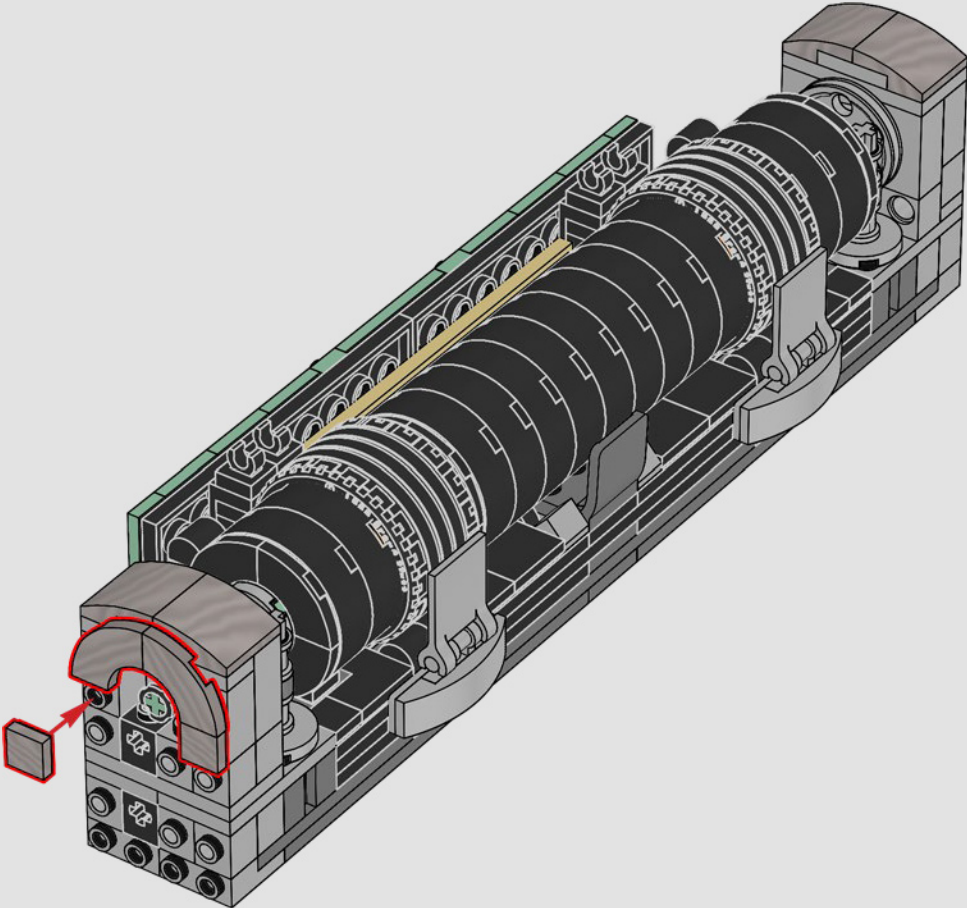

294

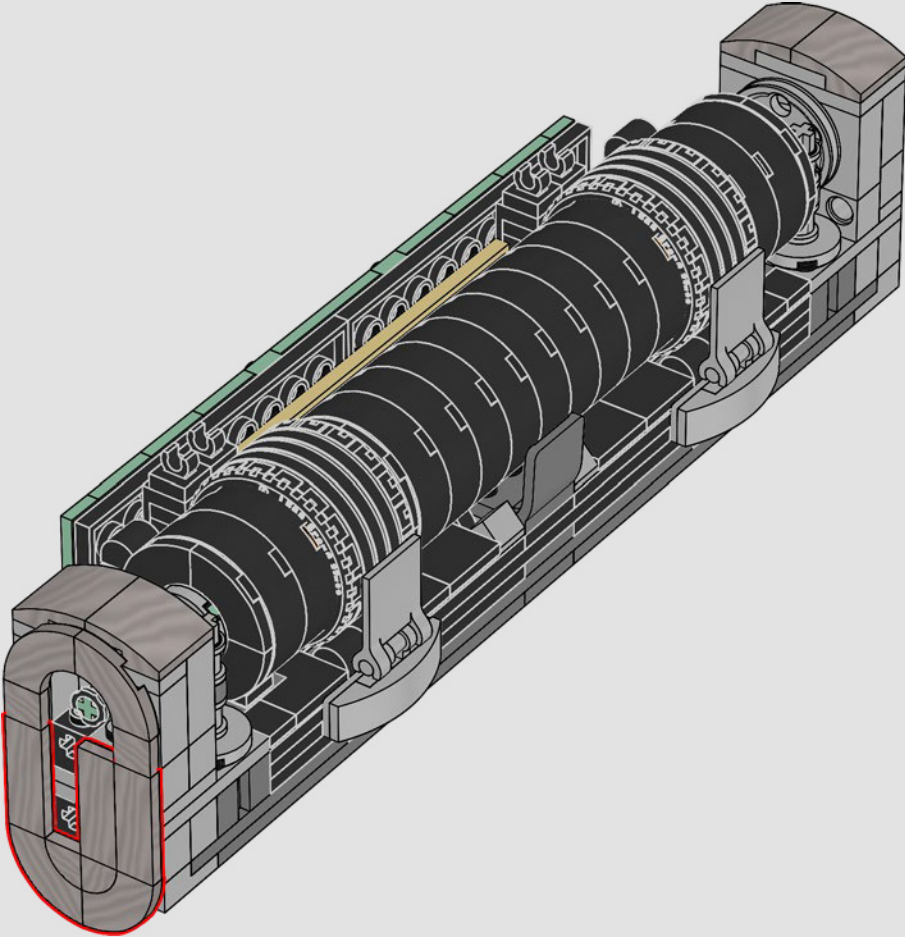

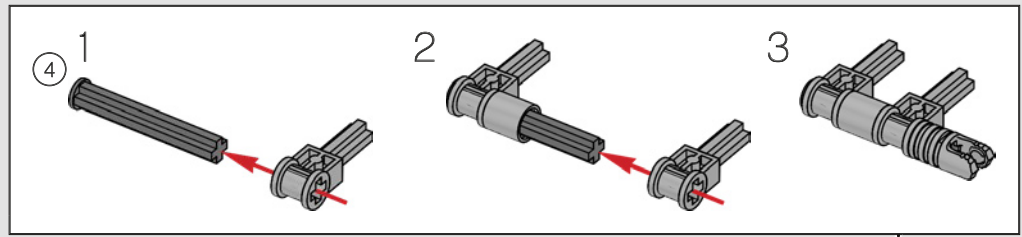
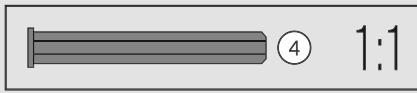
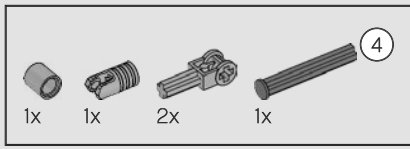

295

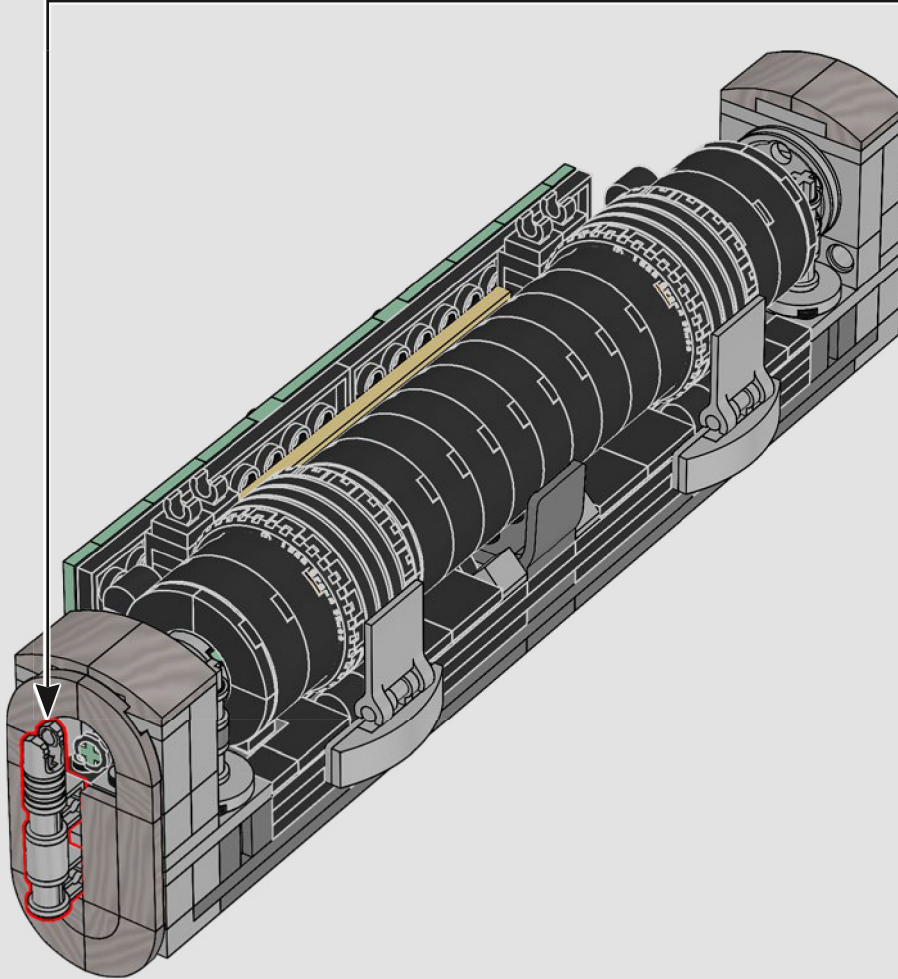

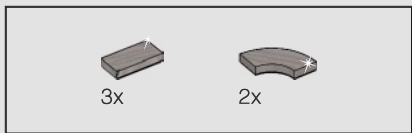

296

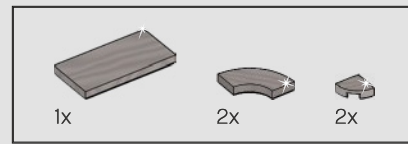
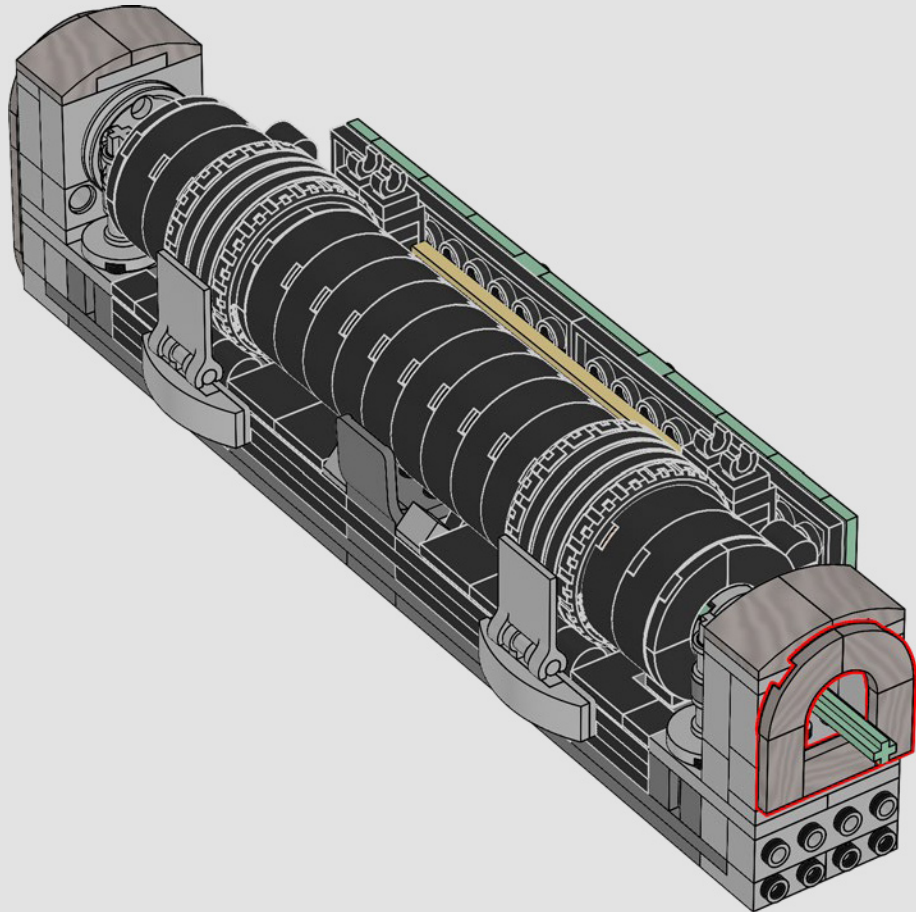

297

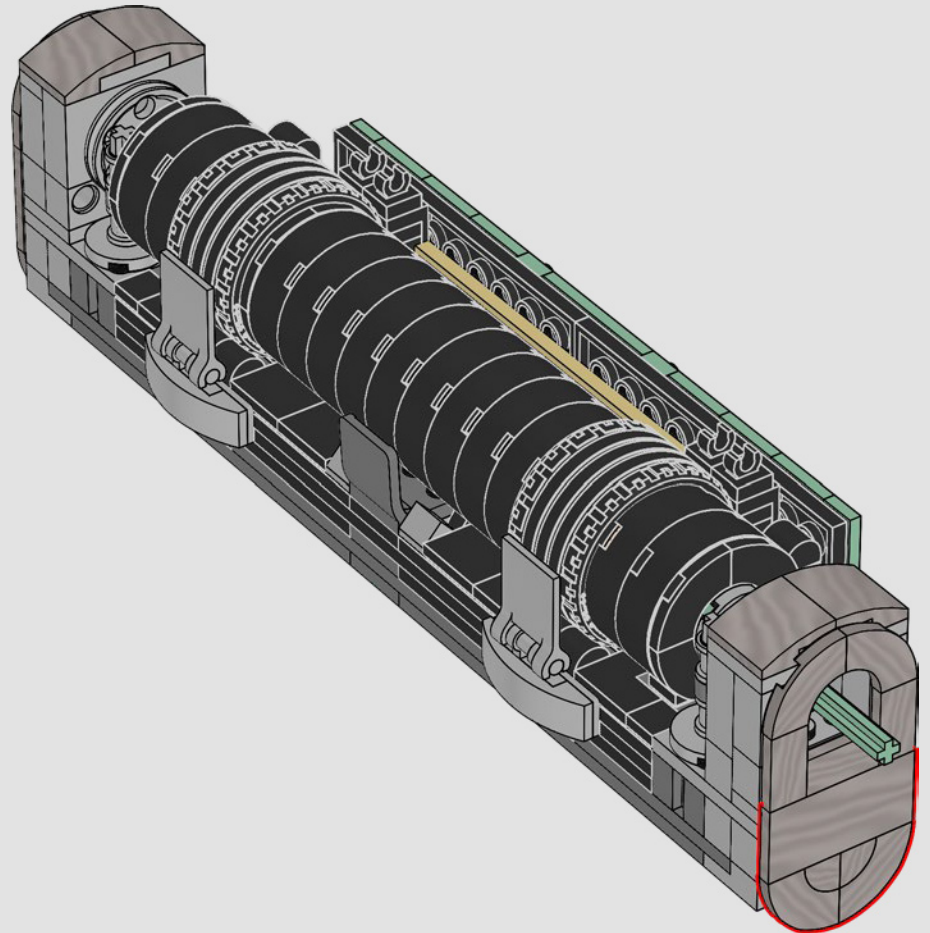

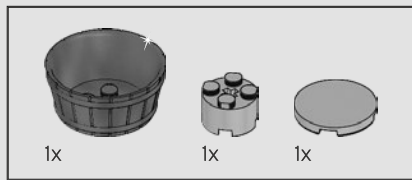

298

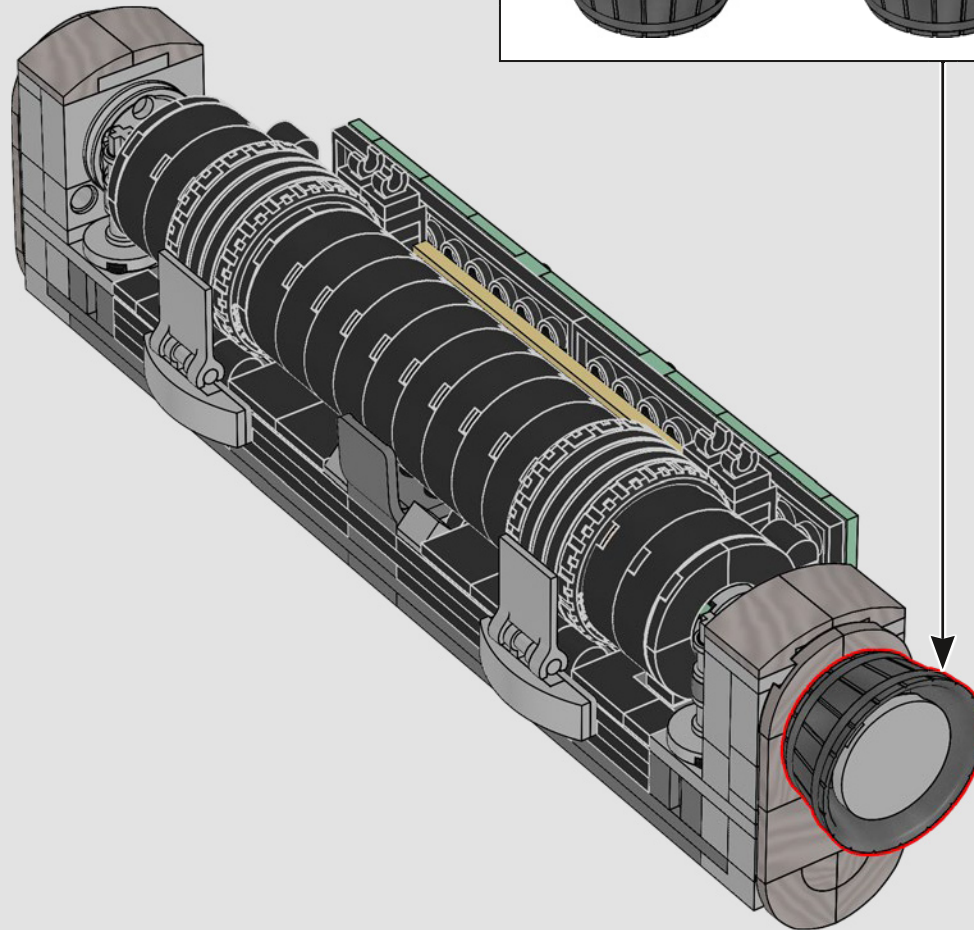
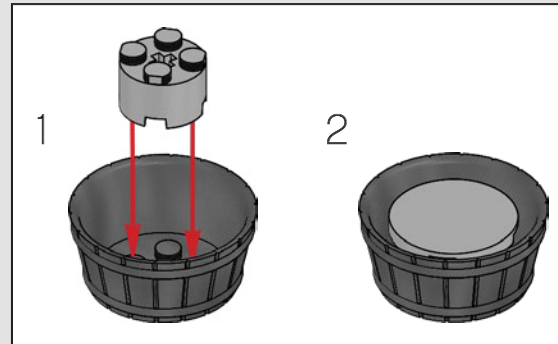

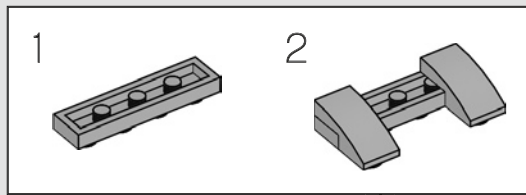
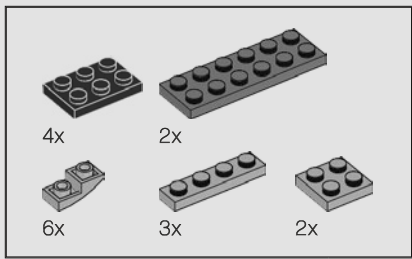

299

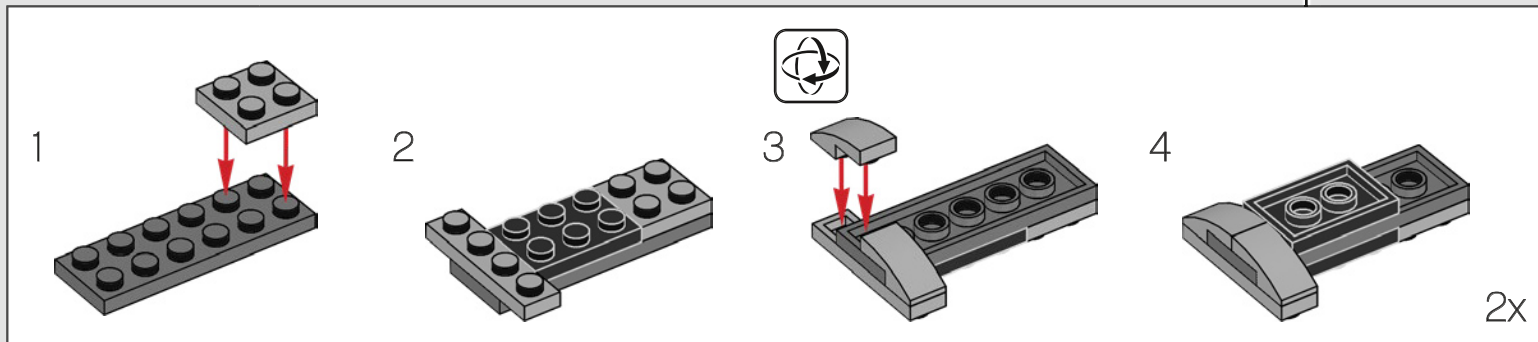
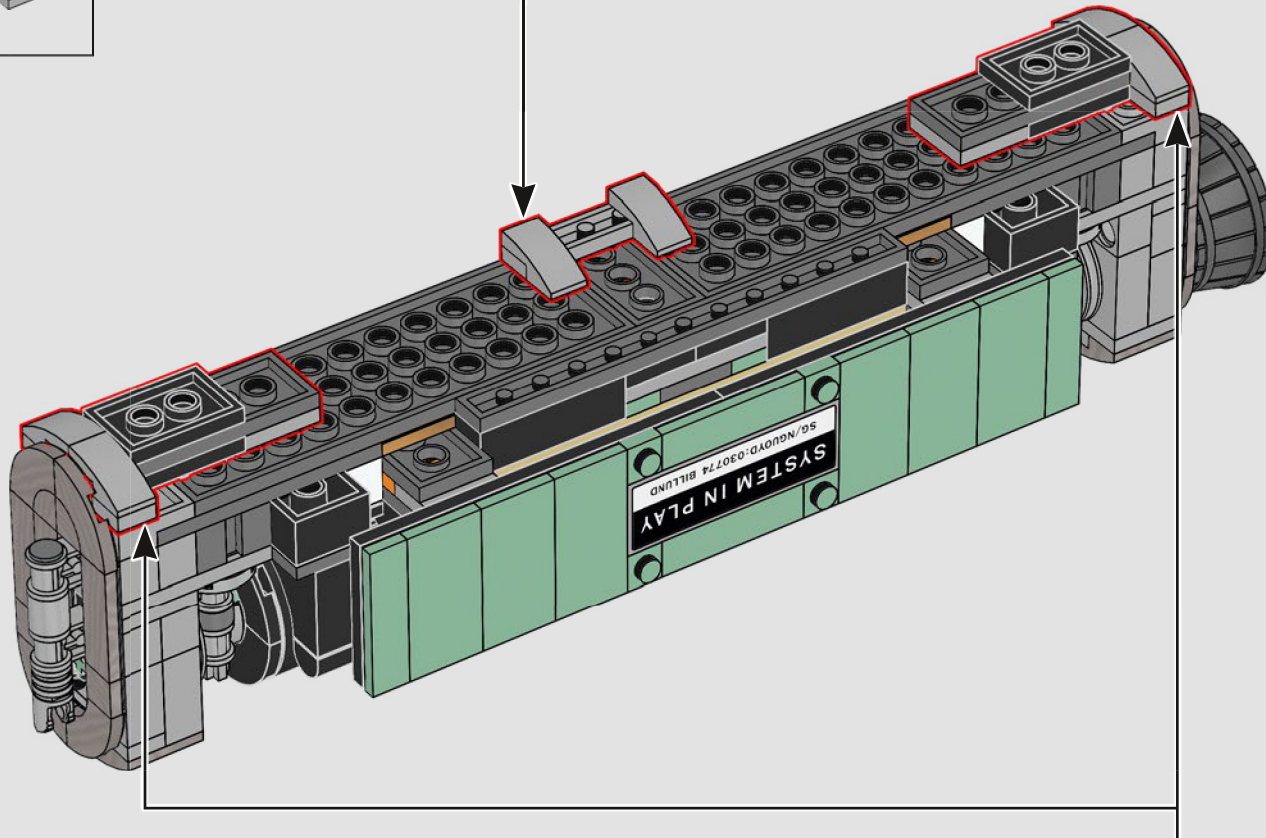

300

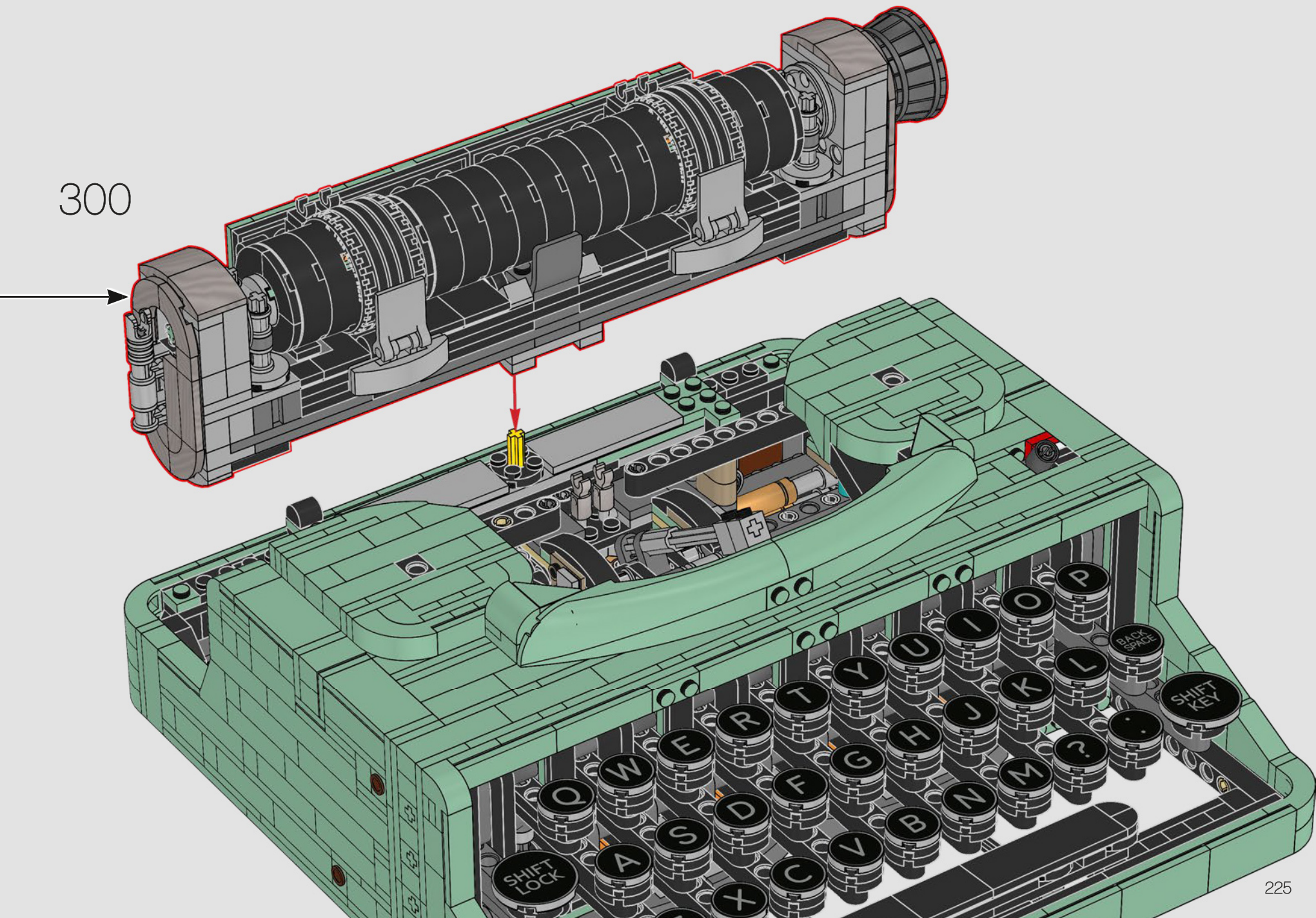

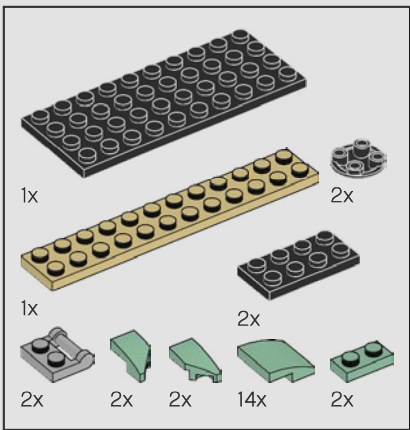

301

1

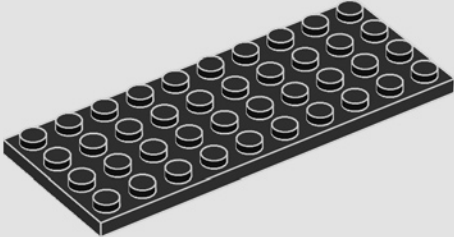

2

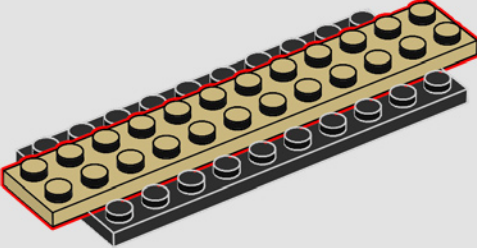

3

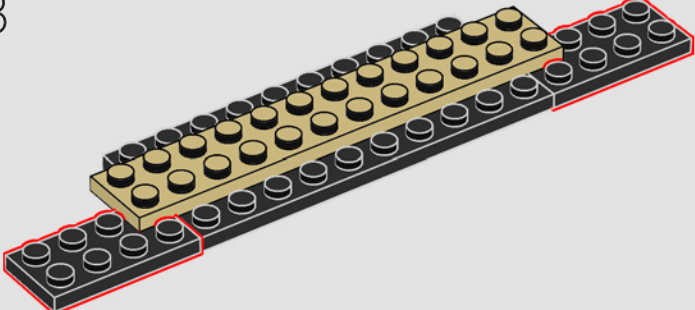

4

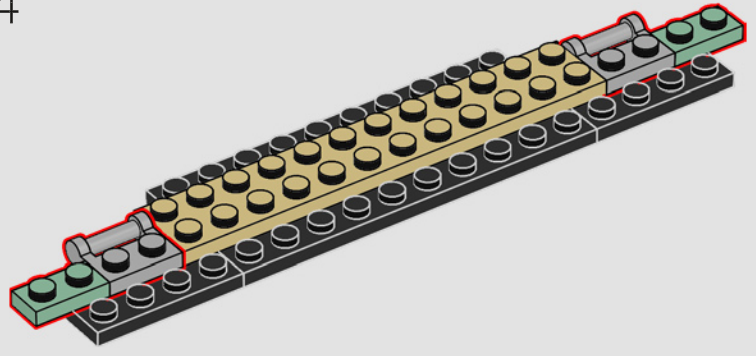

5

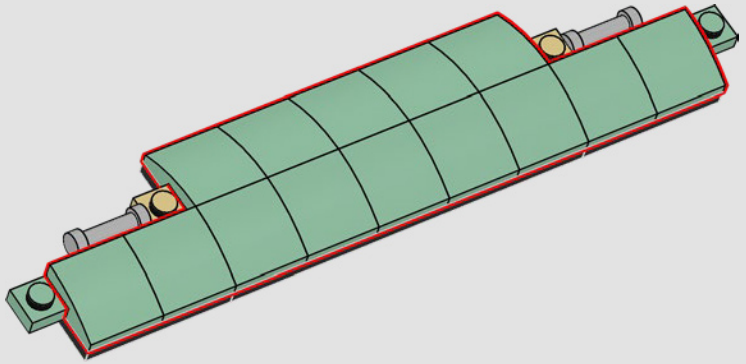

6

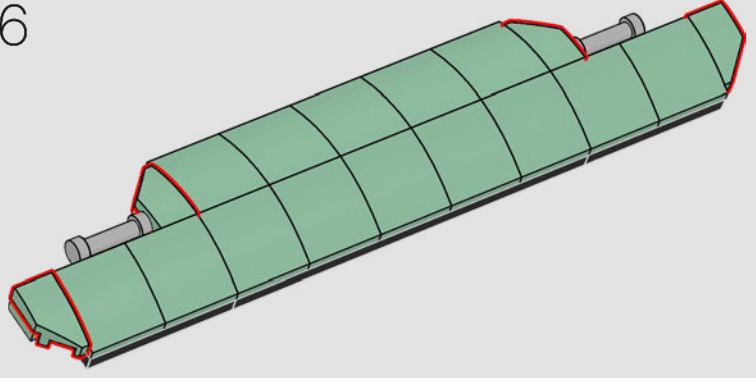

7

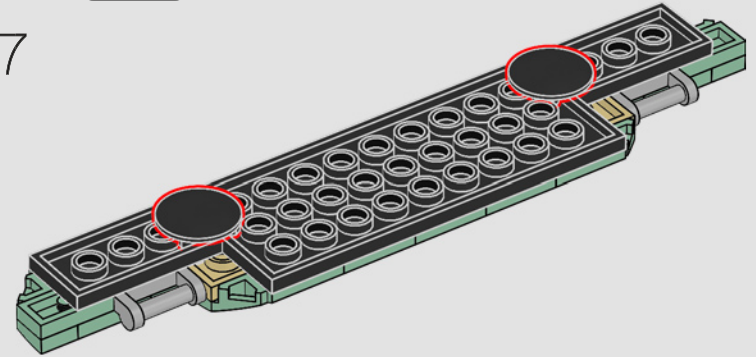

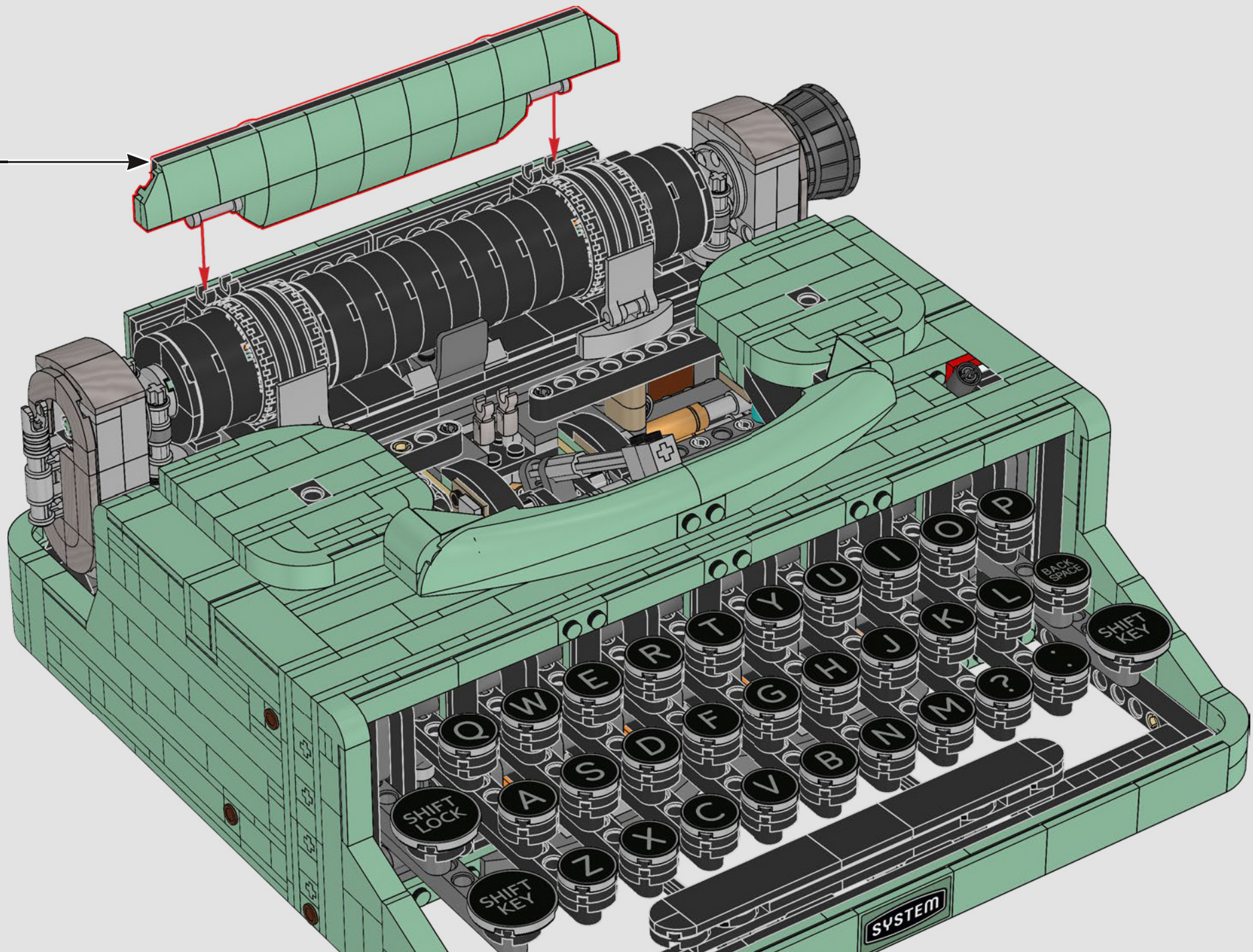

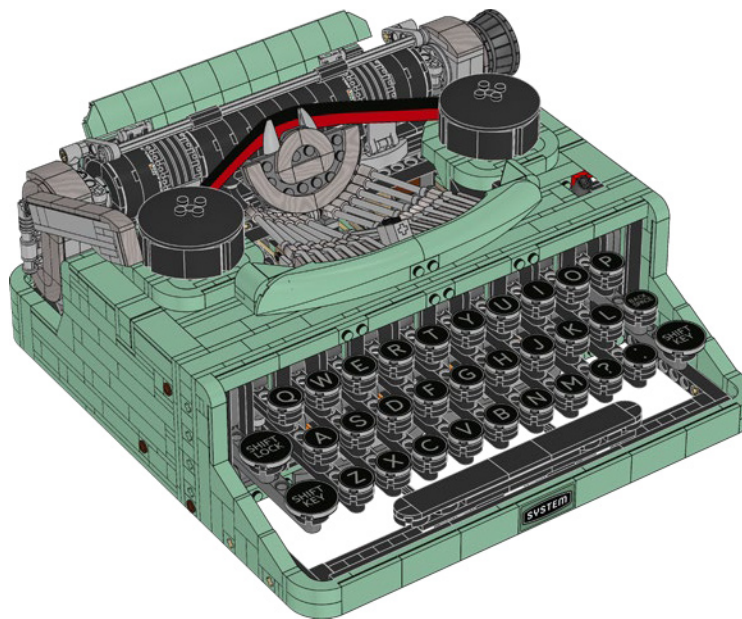

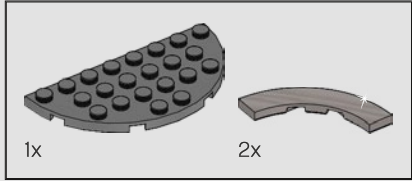
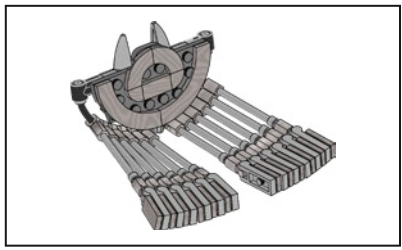

302

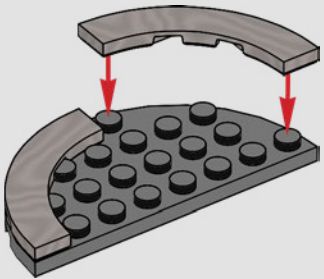

303

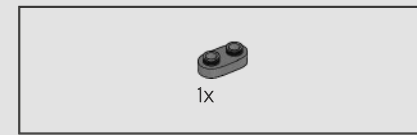
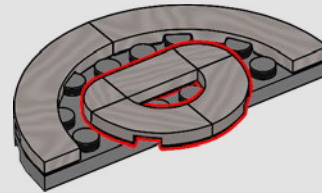

304

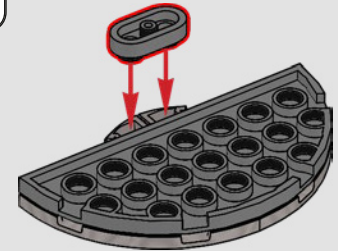
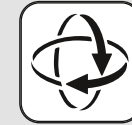

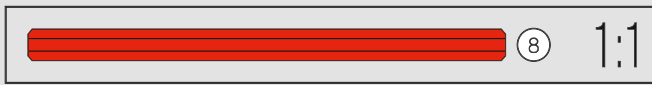
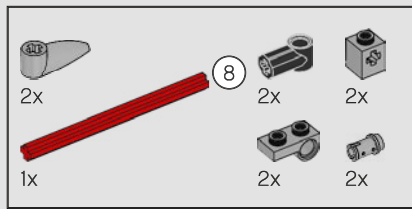

305

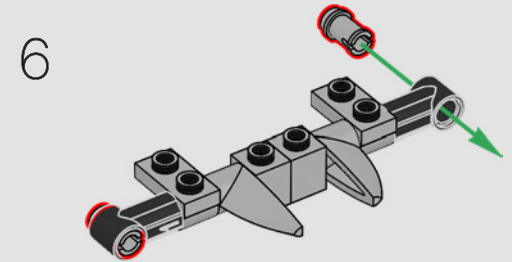
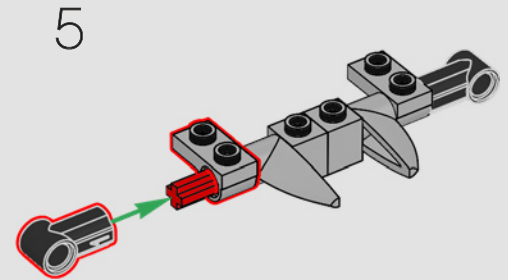
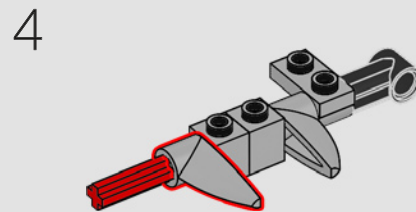
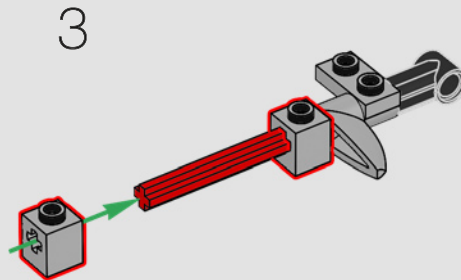
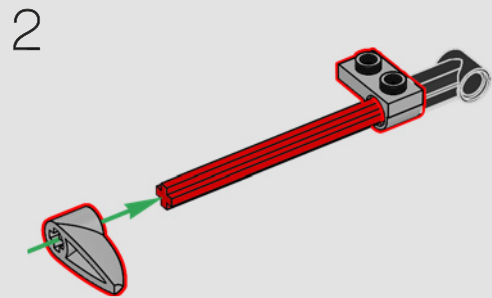
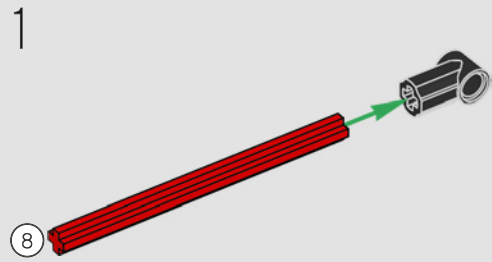

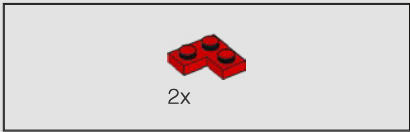
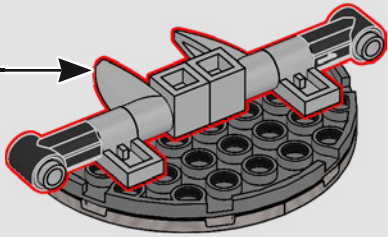

306

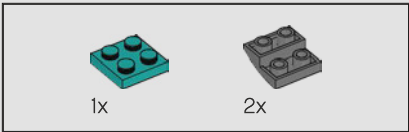
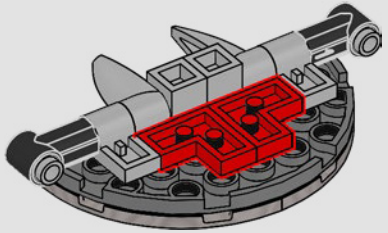

307

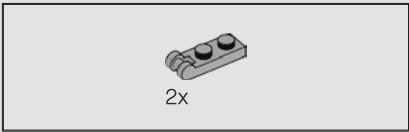
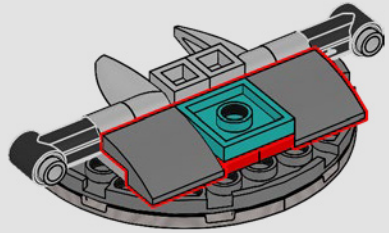

308

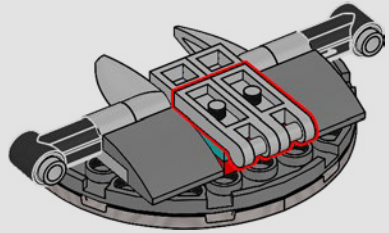

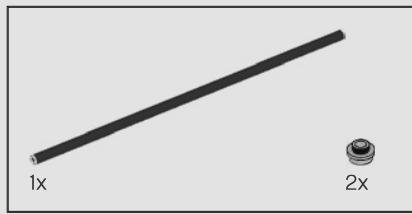

309

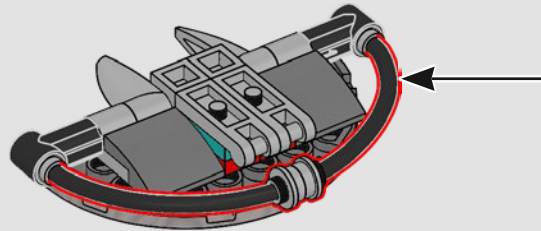
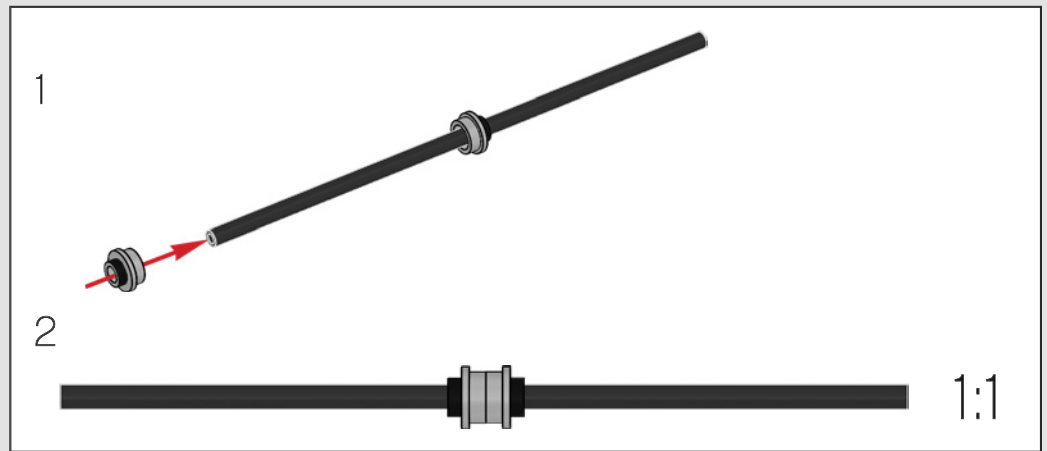

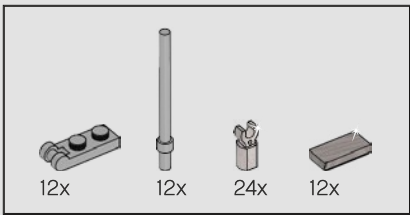

310

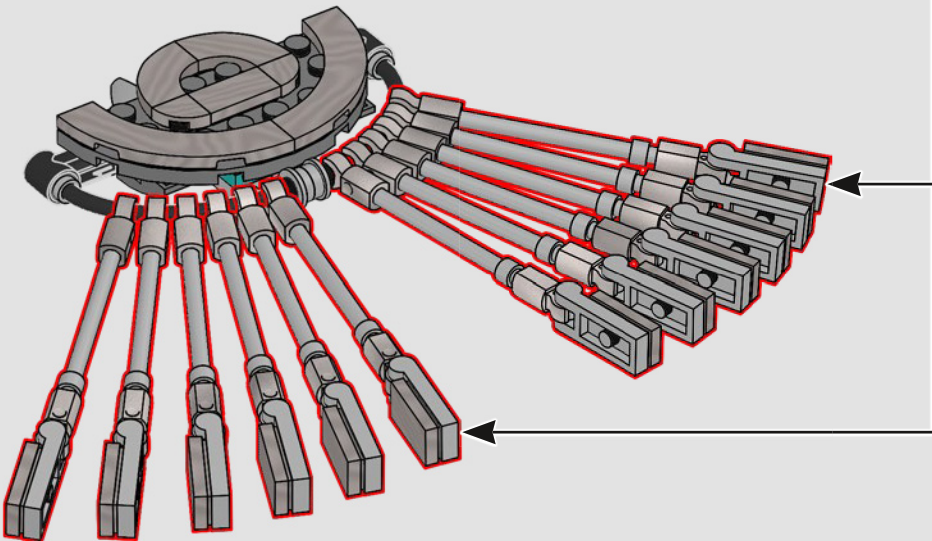
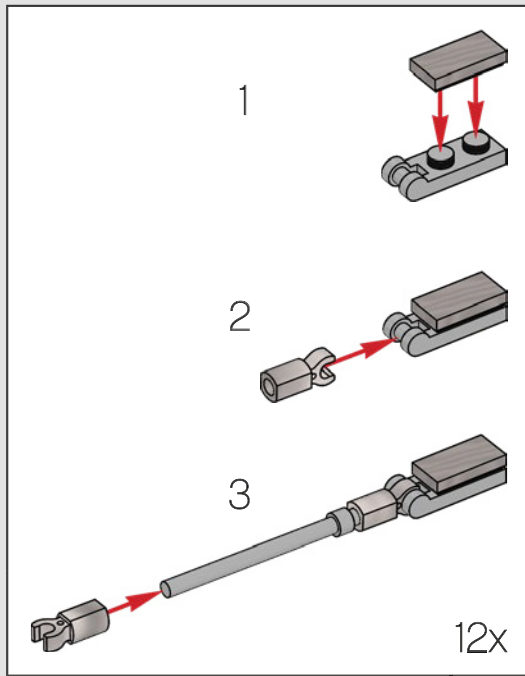

311

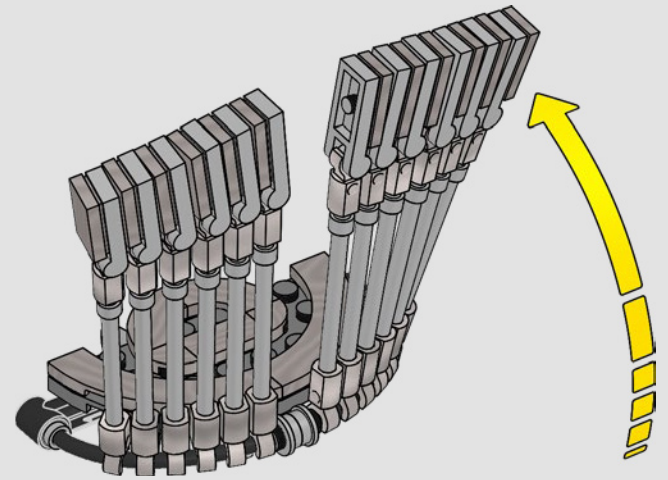

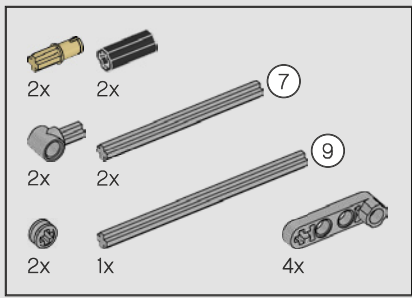

313

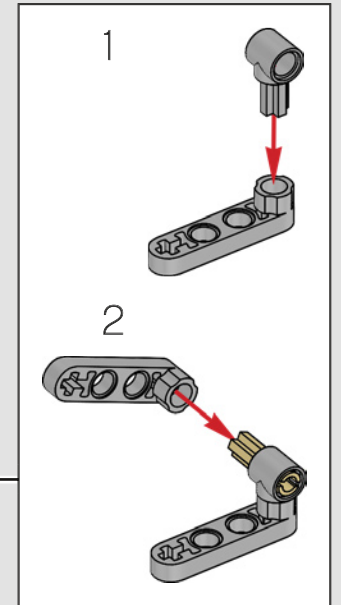
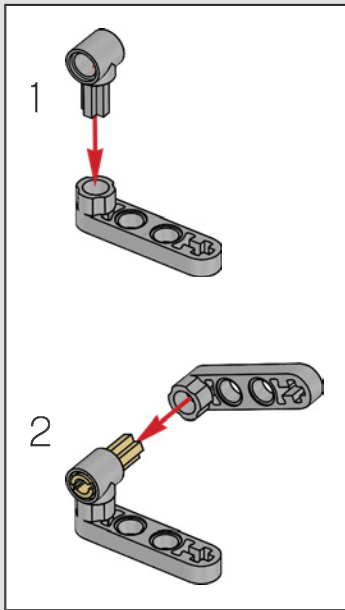
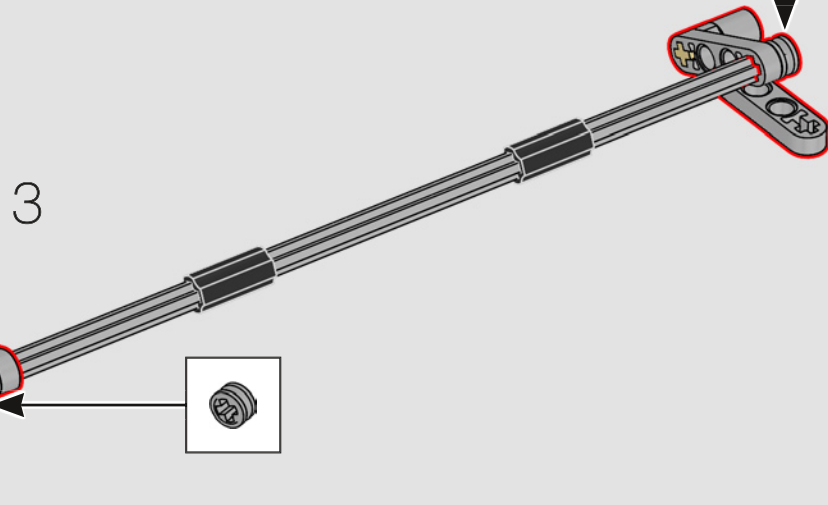
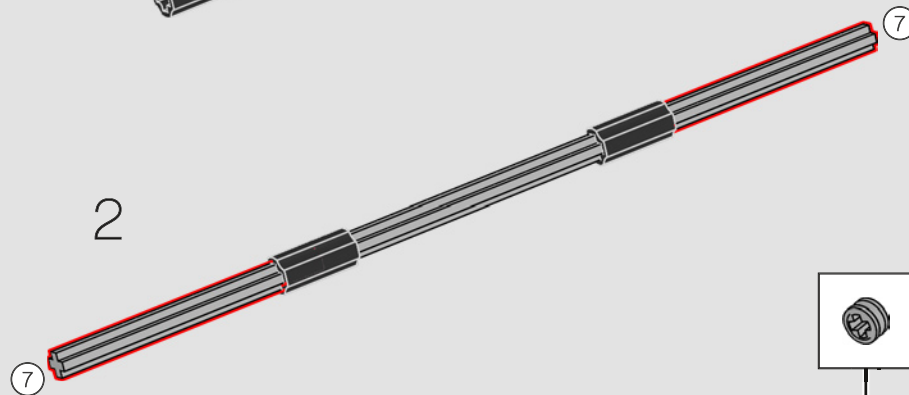
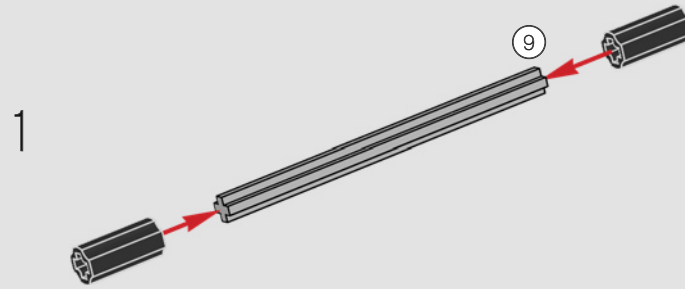
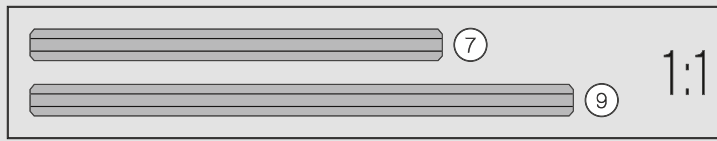

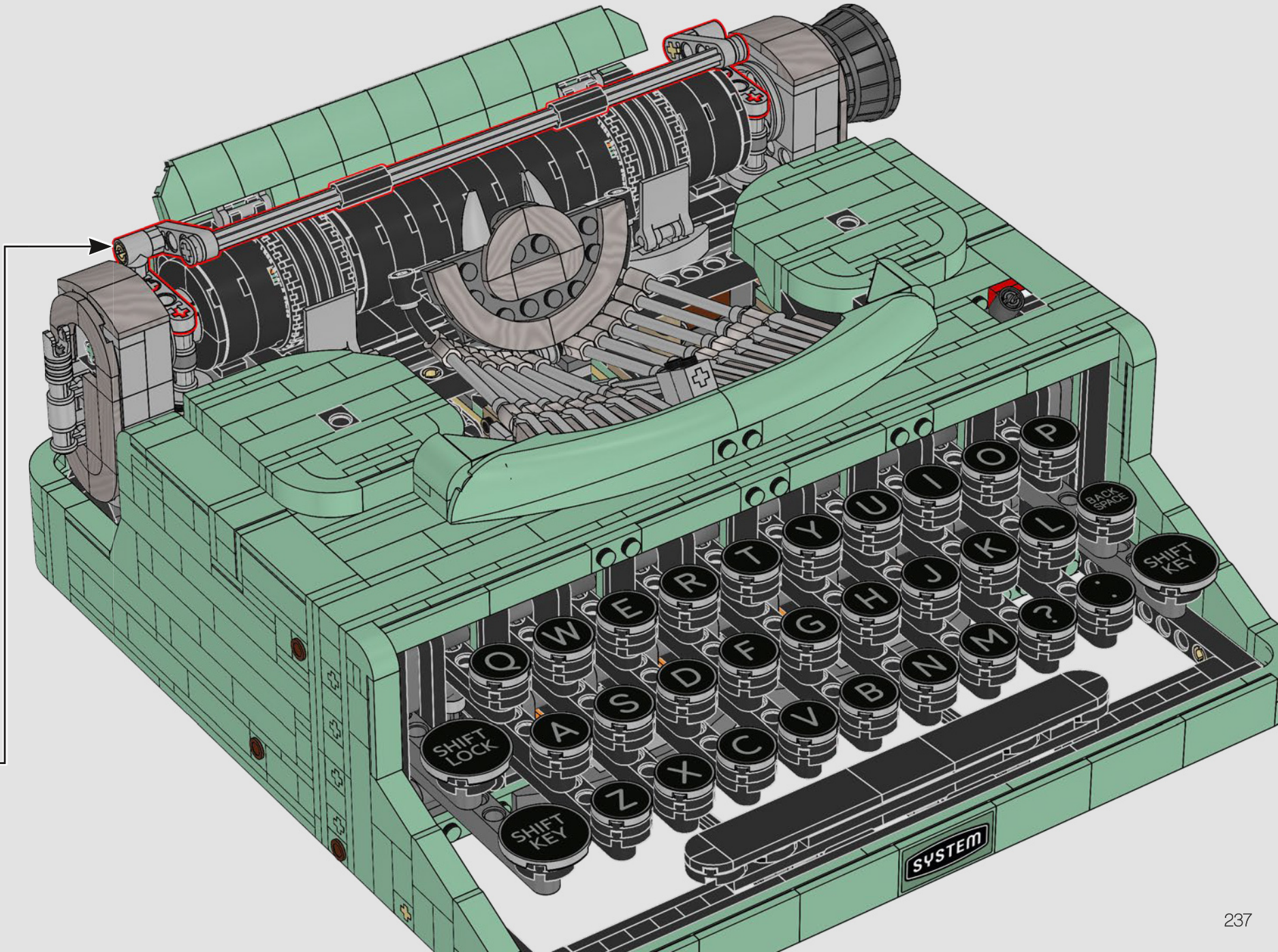

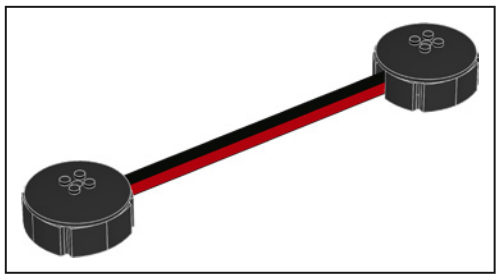

314

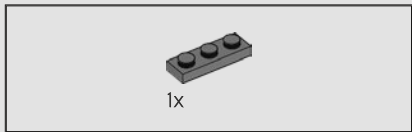
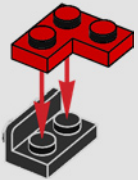

315

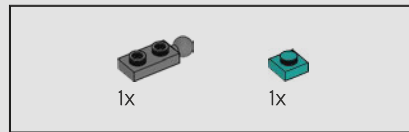
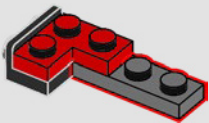

316

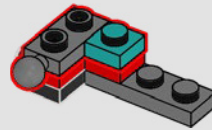

317

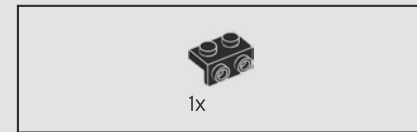
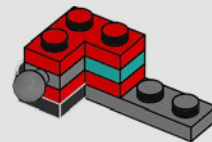

318

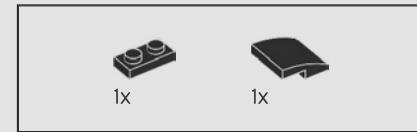
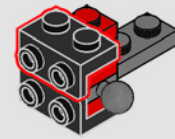

319

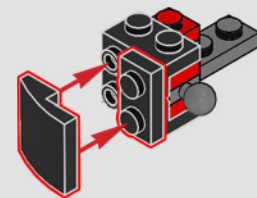

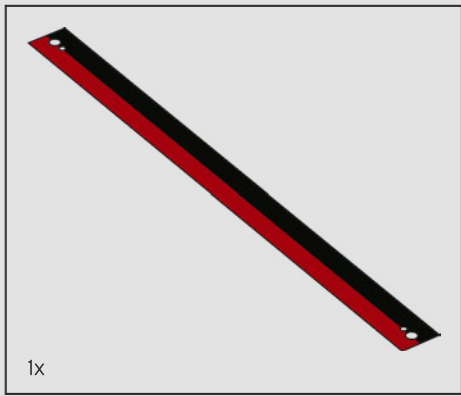

320

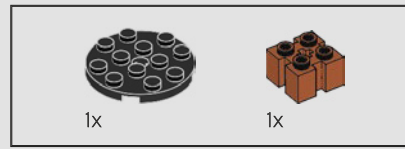

321

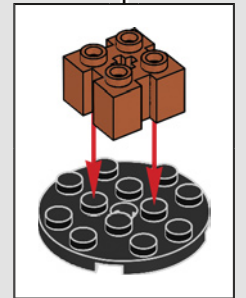

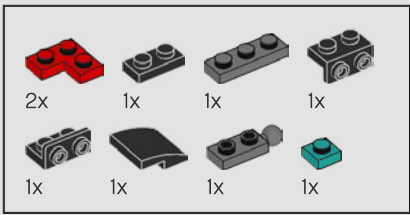

322

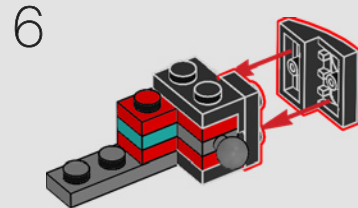
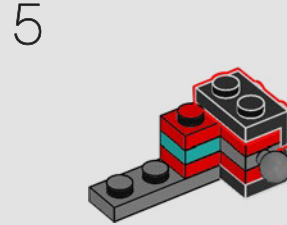
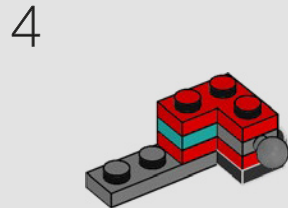
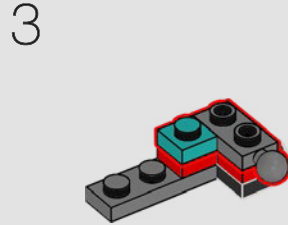
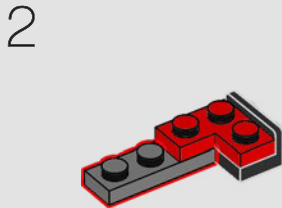
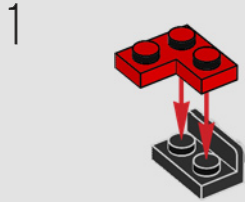

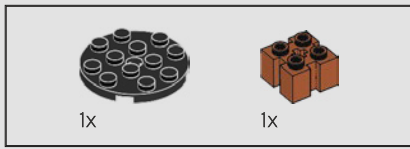

323

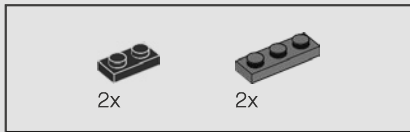
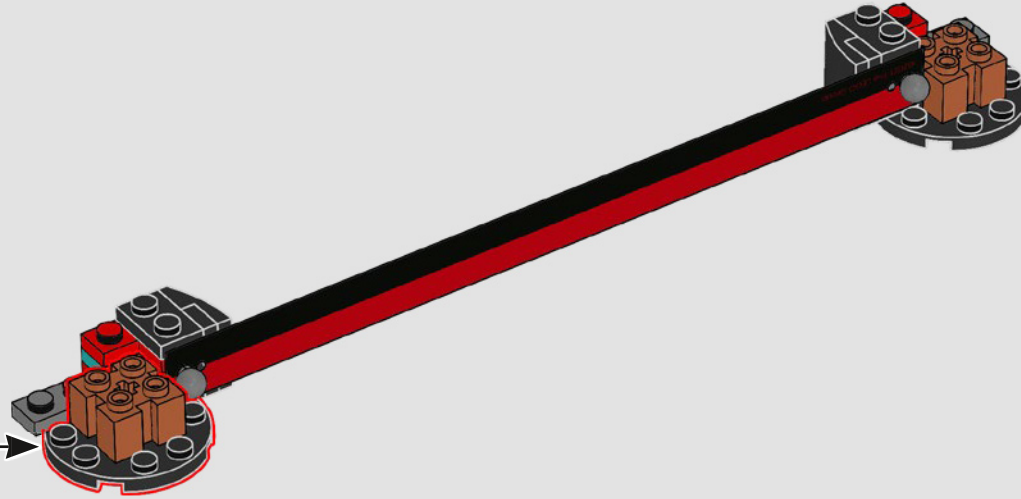
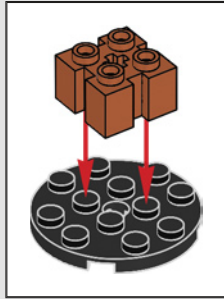

324





325

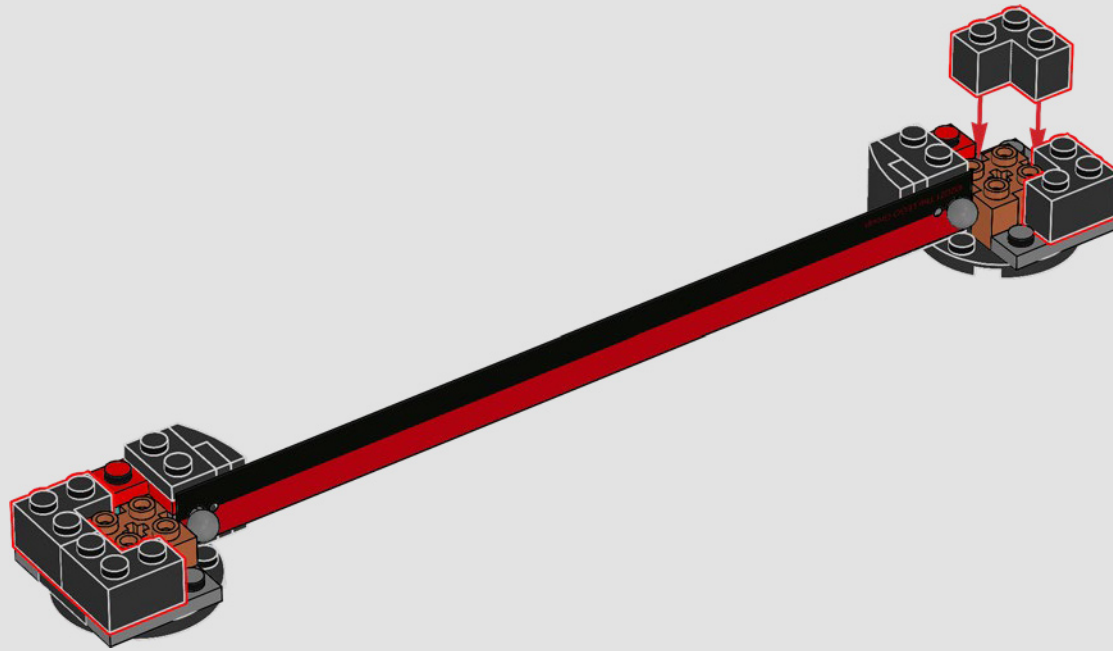

326





327

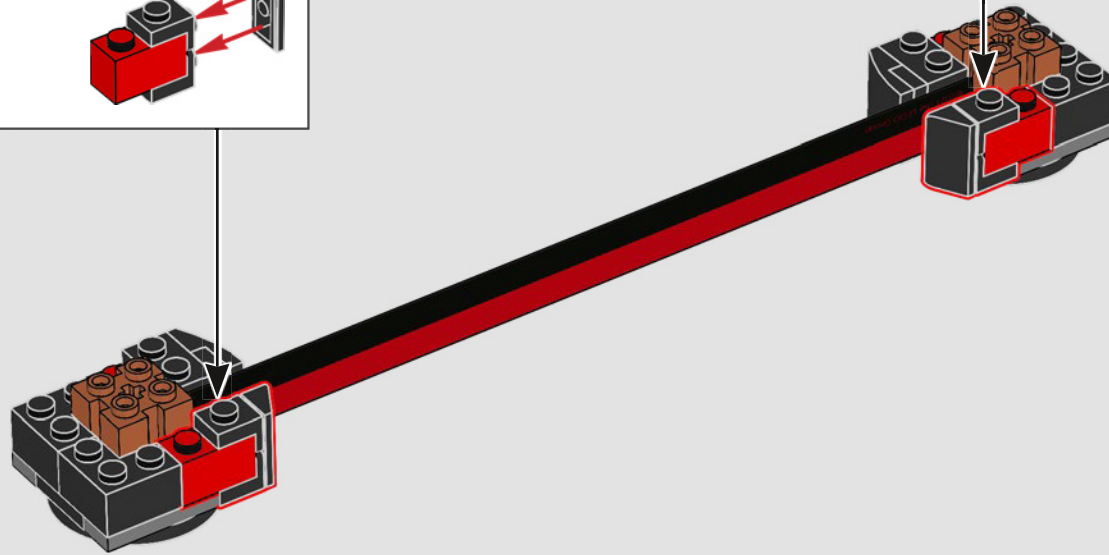
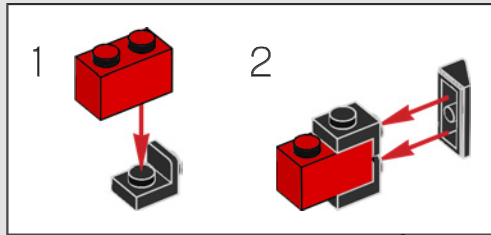
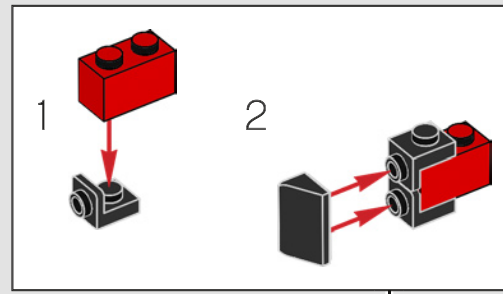



328

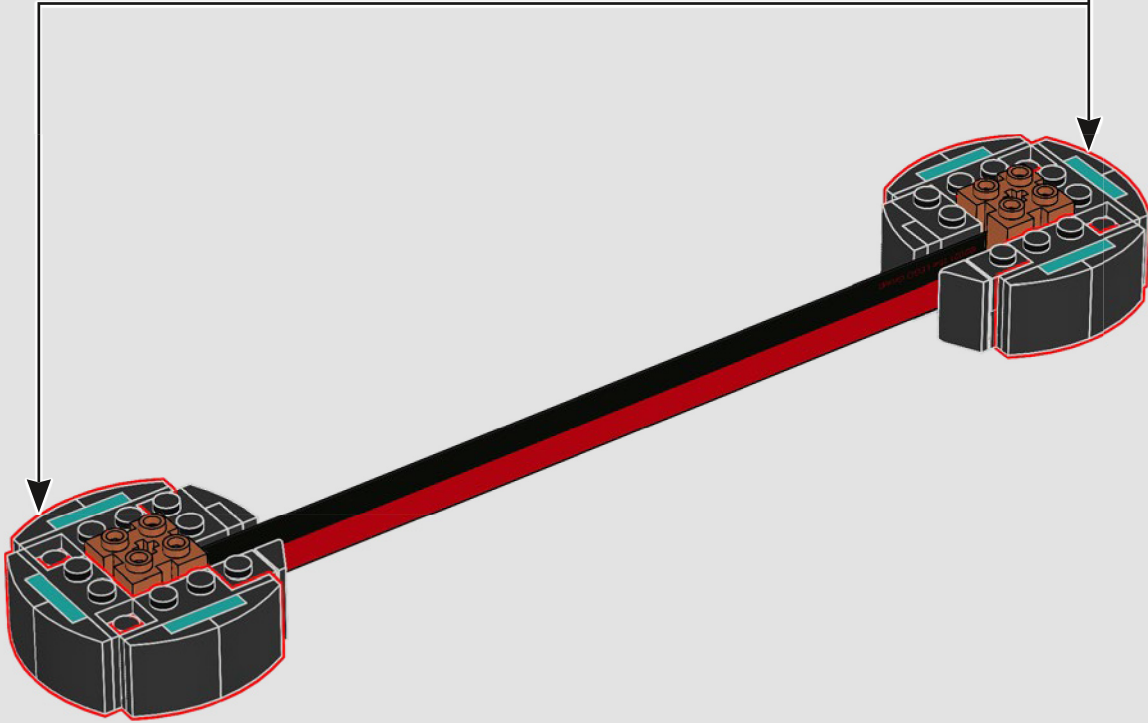
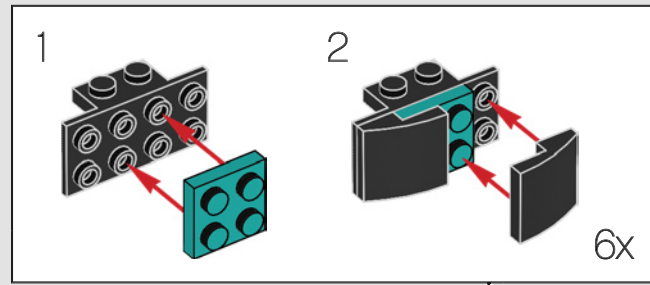

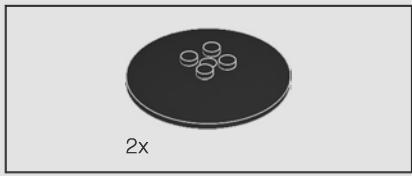

329





330

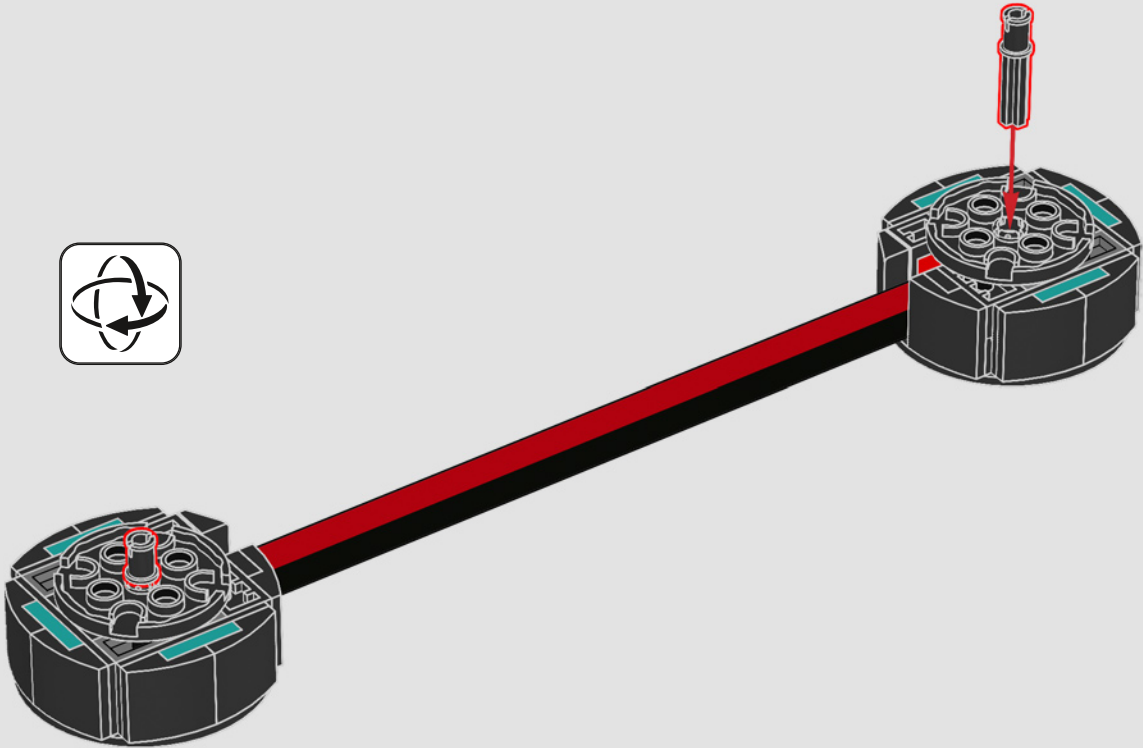

331

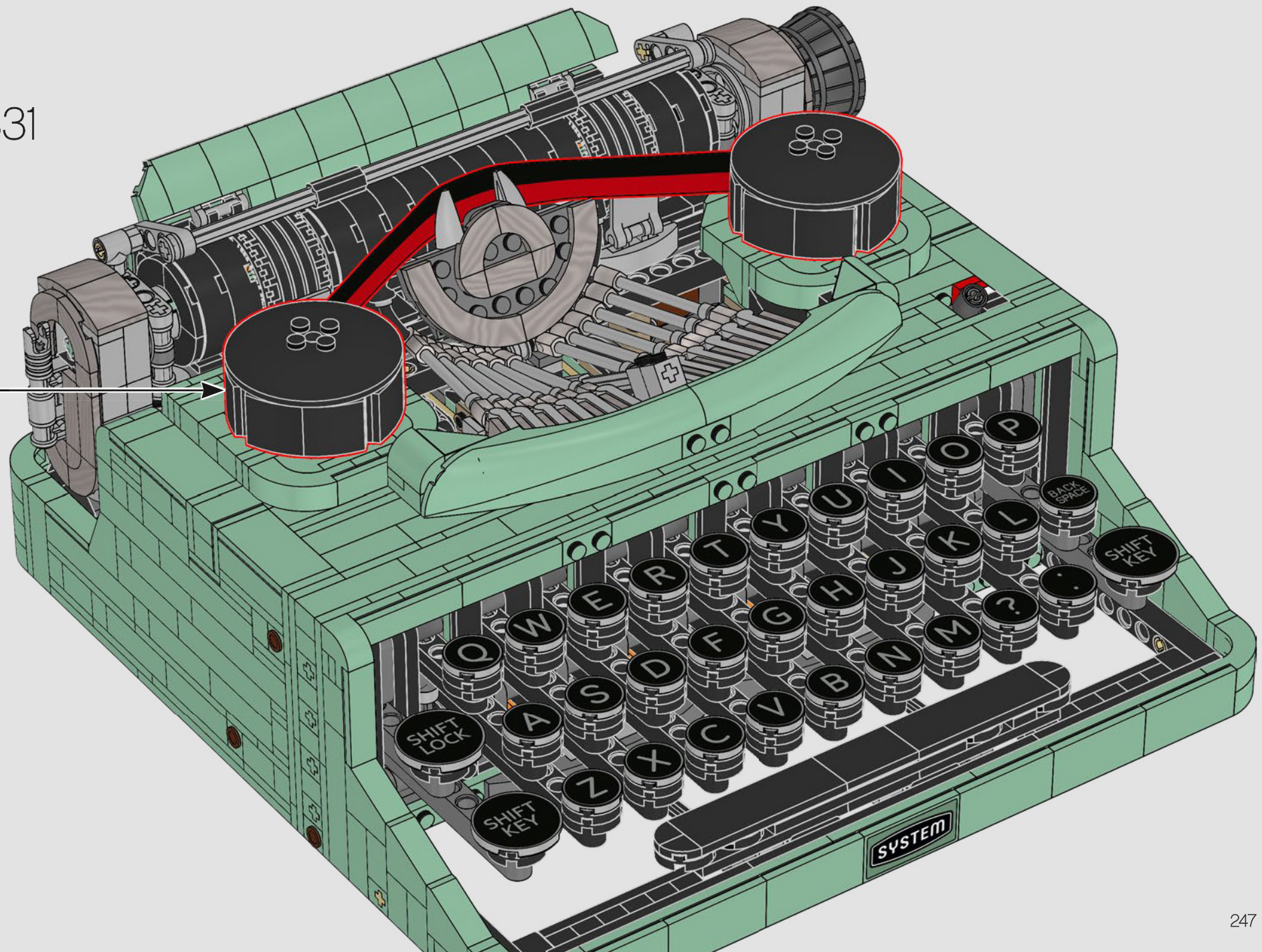

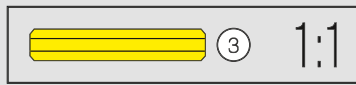
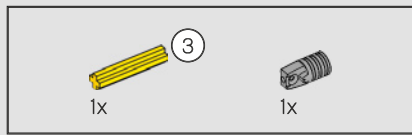

336

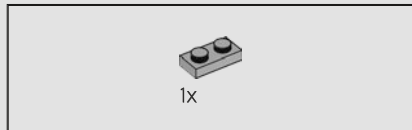
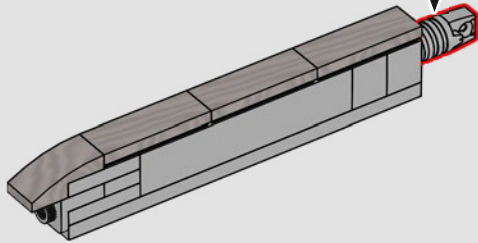
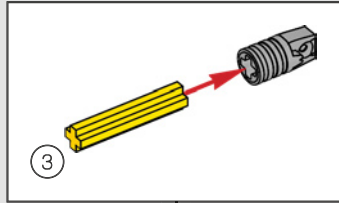

337

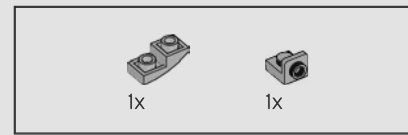
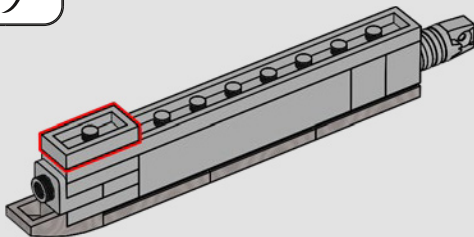

338

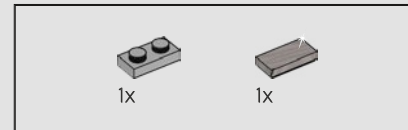
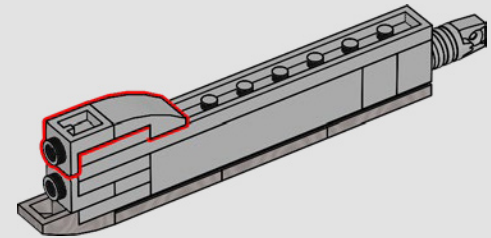

339

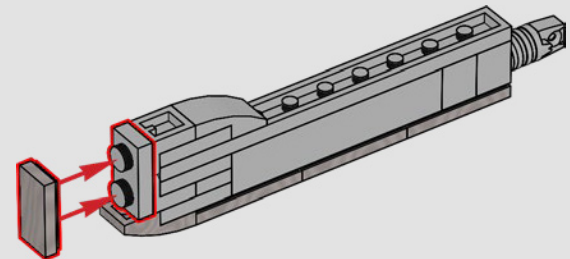

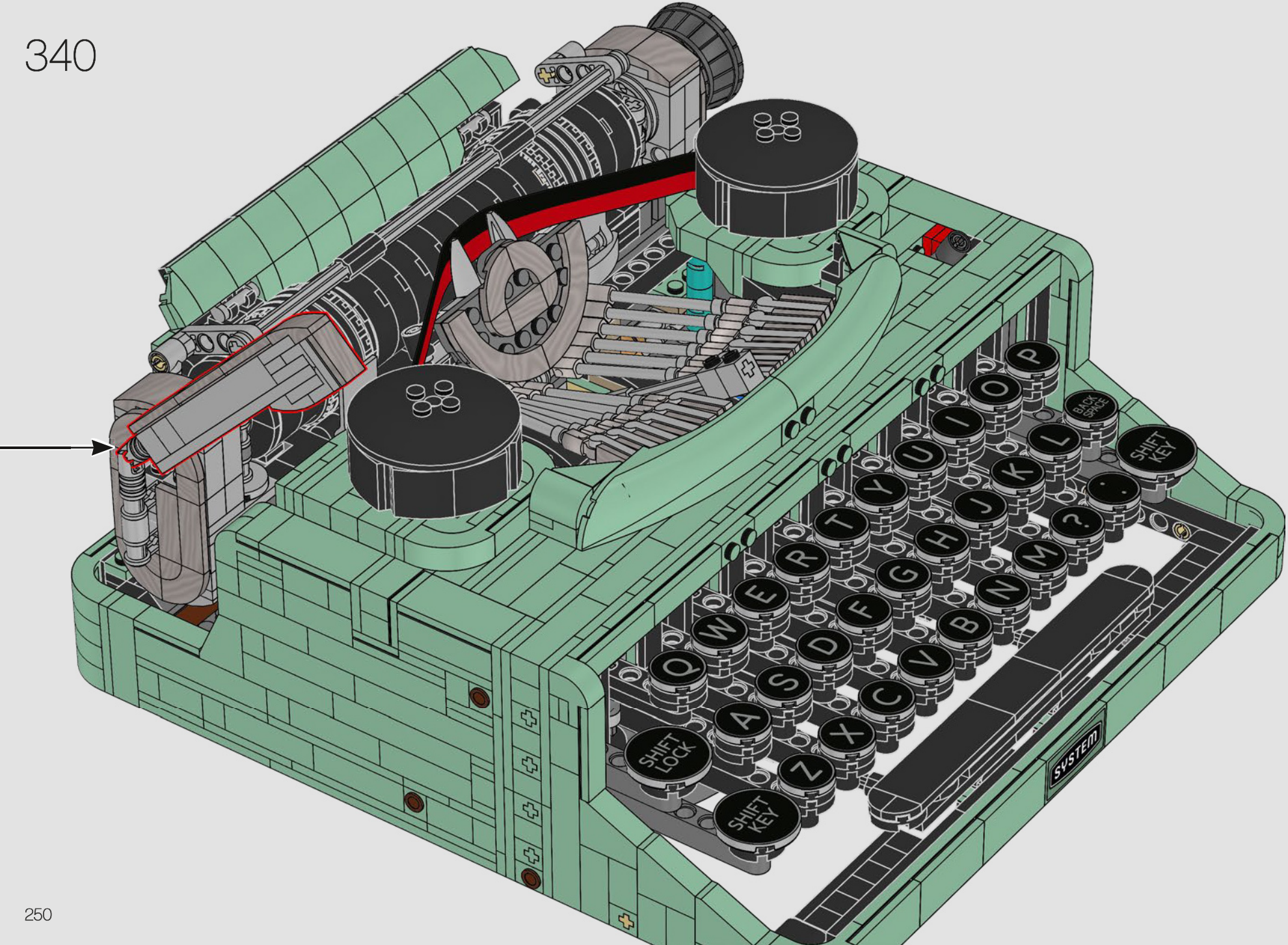

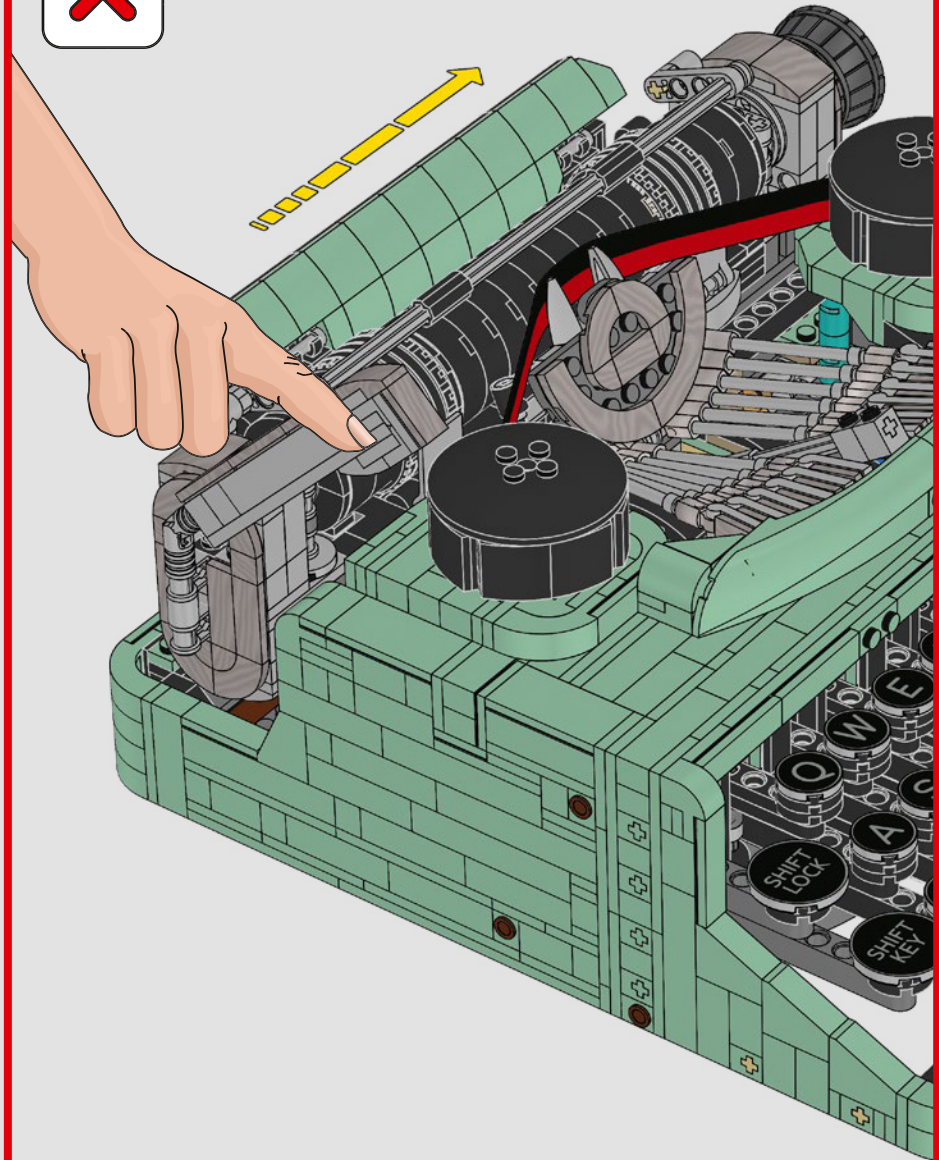
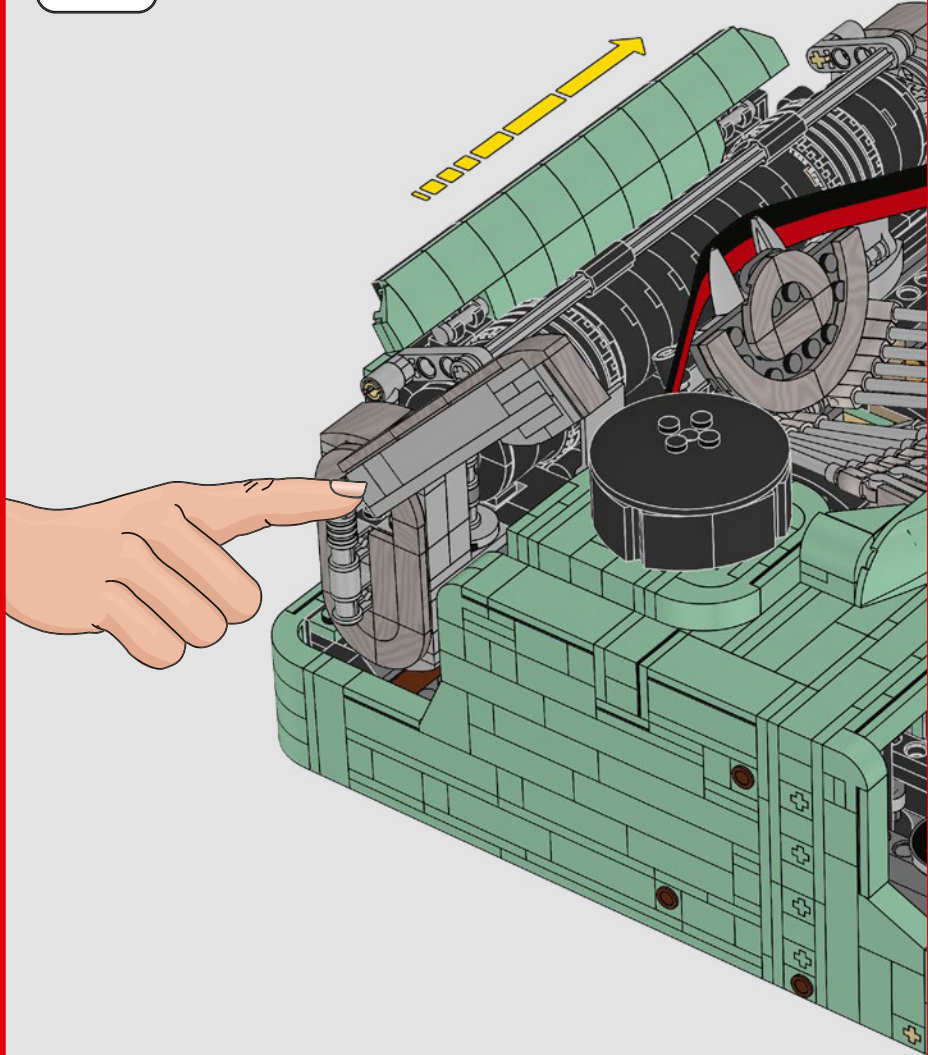





IDEAS

GATHER SUPPORT
OBTIENS DE L'APPUI
OBTÉN APOYOS

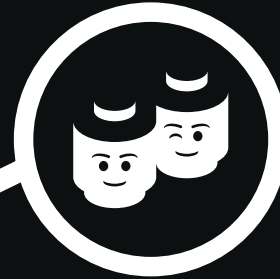

SHARE YOUR IDEA
PARTAGE TON IDÉE
COMPARTE TU IDEA

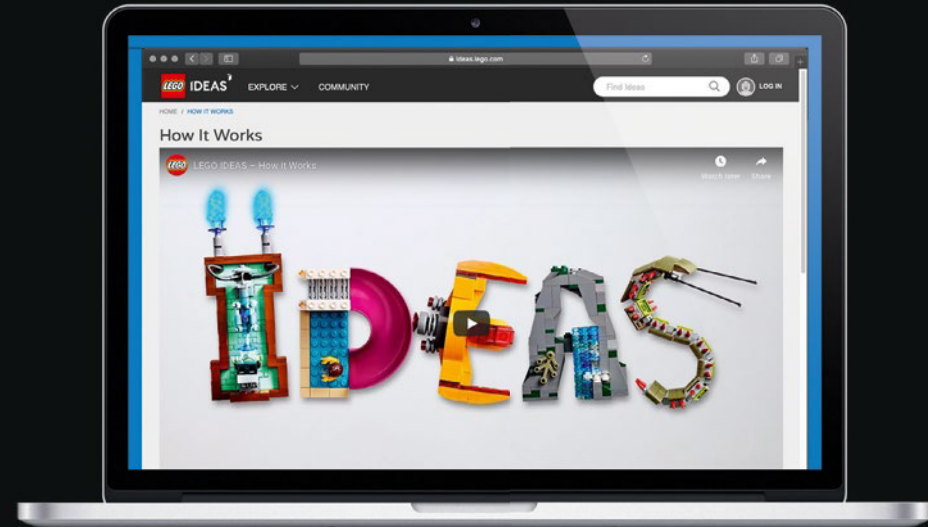
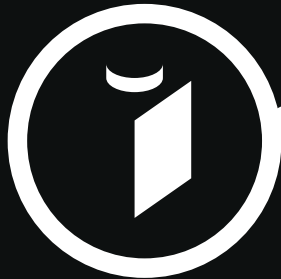

NEW LEGO® PRODUCT
NOUVEAU PRODUIT LEGO®
NUEVO PRODUCTO LEGO®



LEGO® REVIEW
EXAMEN LEGO®
REVISIÓN DE LEGO®





FEEDBACK AND WIN



FEEDBACK AND WIN

Your feedback will help shape the future development of this product series.

Please visit:

FEEDBACK UND GEWINNEN

Dein Feedback trägt zur Weiterentwicklung dieser Produktreihe bei.

Geh auf:

COMMENTEZ ET GAGNEZ

Vos commentaires nous aideront à concevoir les futurs produits de cette gamme.

Rendez-vous sur :

COMENTA Y GANA

Tu opinión nos ayudará a dar forma al desarrollo de esta serie de productos en el futuro.

Visita:

反馈有奖

您的反馈将有助于我们在今后改进本系列产品。

请访问：

[LEGO.com/productfeedback](https://www.lego.com/productfeedback)

By completing, you will automatically enter a drawing to win a LEGO® set.

Terms & Conditions apply.

Durch Ausfüllen nimmst du automatisch an der Verlosung eines LEGO® Preises teil.

Es gelten die Teilnahmebedingungen.

En envoyant vos commentaires, vous serez automatiquement inscrit(e) à un tirage au sort qui vous permettra de remporter un prix LEGO®.

Offre soumise à conditions.

Al contestar, participarás automáticamente en el sorteo y podrás ganar un set LEGO®.

Sujeto a Términos y Condiciones.

完成我们的反馈调查，即可自动进入抽奖环节，赢取乐高®套装。

适用《条款和条件》。

- 2x 6194809
- 2x 6177114
- 1x 302401
- 2x 6332573
- 2x 362201
- 11x 6371416
- 2x 4565452
- 12x 4666579
- 2x 6214334
- 1x 6346517
- 6x 6321305
- 4x 6020375
- 2x 4113233
- 5x 6093864
- 4x 6330369

- 7x 6271820
- 2x 302421
- 13x 4142865
- 2x 300421
- 3x 302321
- 1x 6285599
- 9x 6359066
- 2x 6313190
- 6x 242021
- 20x 6209519
- 1x 6276963
- 1x 6330205
- 2x 6129995
- 4x 6130002
- 2x 4616342

- 1x 6130004
- 1x 6352565
- 2x 4143005
- 9x 6323908
- 42x 4206482
- 3x 6330996
- 4x 302323
- 8x 6344176
- 8x 6299413
- 4x 302123
- 1x 346023
- 2x 6271167
- 2x 4107800

- 1x 6268925
- 15x 6130007
- 2x 6267046
- 9x 6327559
- 1x 6130008
- 1x 6115616
- 4x 6343854
- 2x 6332148
- 1x 6121485
- 8x 6273589
- 14x 6344819
- 4x 6172383
- 4x 307026
- 7x 302426
- 4x 6335388
- 2x 4106347
- 8x 654126

- 5x 300526
- 2x 6234695
- 2x 6299338
- 2x 4516843
- 1x 4177431
- 4x 6284699
- 2x 4548180
- 2x 4278359
- 70x 403226
- 34x 6279875
- 4x 6099801
- 10x 6265091
- 2x 4143466
- 4x 4512363
- 2x 4636202

- 2x 6267487
- 11x 306926
- 13x 302326
- 4x 300426
- 2x 6016172
- 2x 6117973
- 2x 6020193
- 2x 4584274
- 2x 6000650
- 8x 6271810
- 2x 6273708
- 14x 6053077
- 12x 6191630
- 10x 242026
- 2x 6265730

- 2x 6133722
- 4x 235726
- 7x 6089119
- 6x 4142822
- 2x 6362991
- 1x 6328175
- 14x 362326
- 6x 6154860
- 2x 428726
- 12x 6118829
- 34x 4198367
- 2x 6327548
- 1x 6162892
- 5x 302126

- 1x 370526
- 2x 4613153
- 2x 6267482
- 2x 4515350
- 13x 4558957
- 2x 6174917
- 2x 416126
- 12x 6327028
- 4x 6331437
- 4x 4560182
- 3x 302026
- 4x 300126
- 3x 4142135

- 2x 4499234
- 20x 6163980
- 5x 370626
- 2x 366626
- 2x 6058341
- 2x 3200126
- 1x 379526
- 1x 4181144
- 2x 6318582
- 1x 346026
- 2x 416226

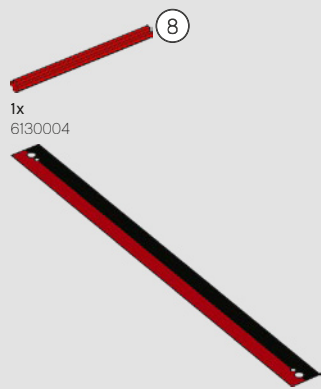

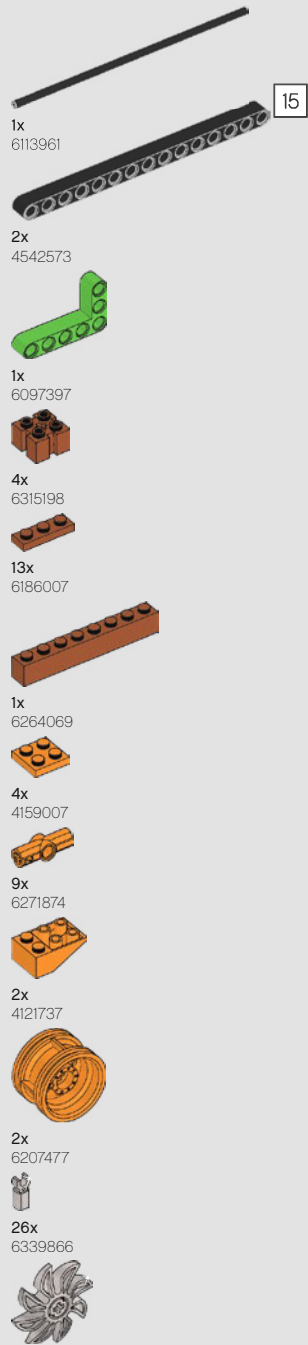

15

9

13

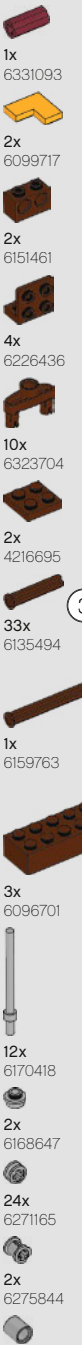
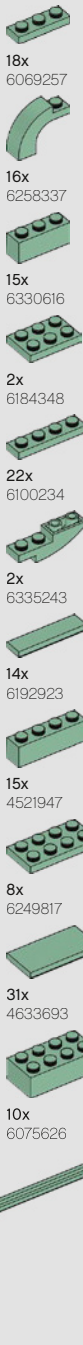
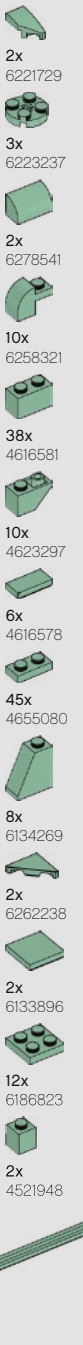

3

5



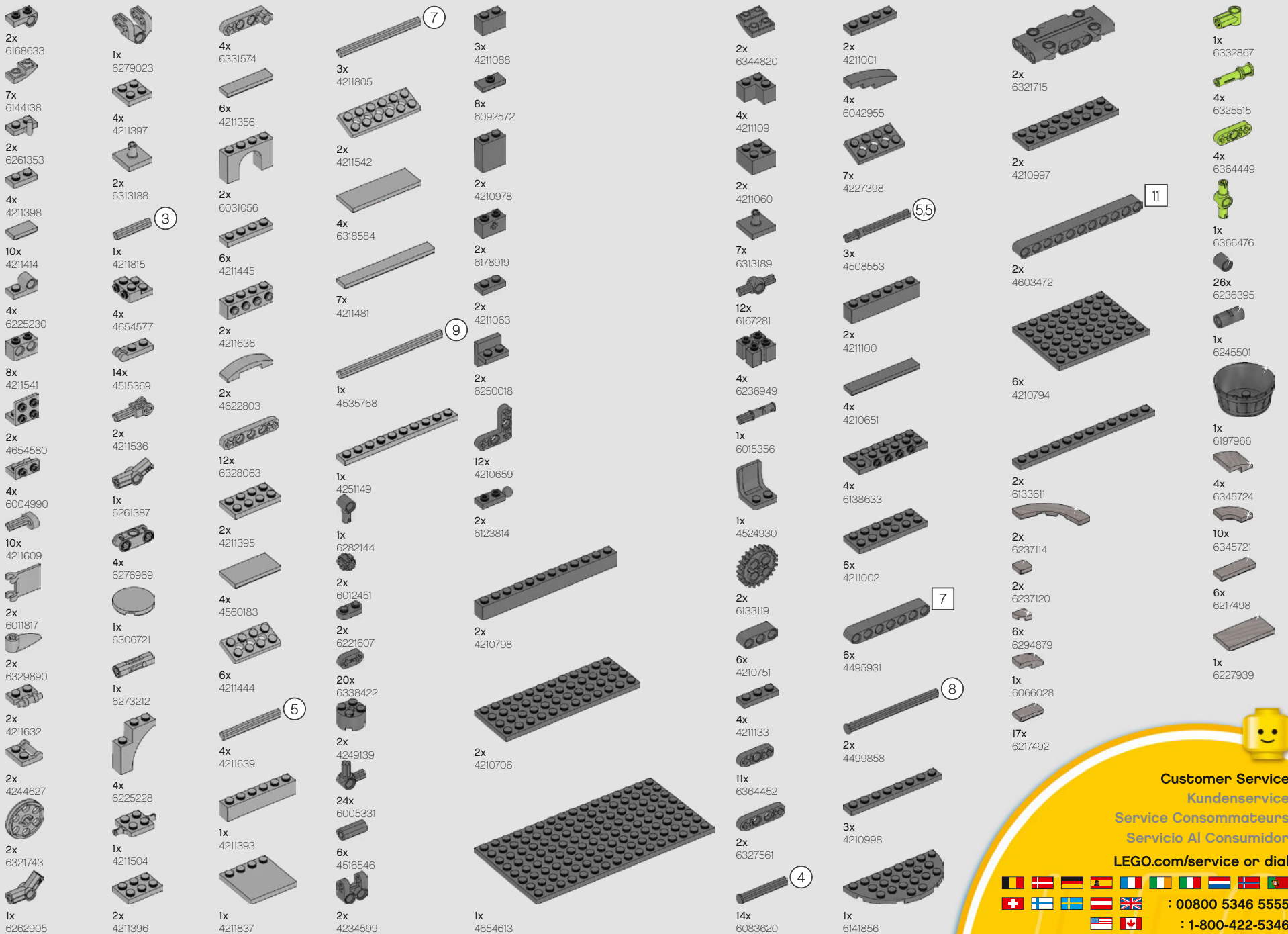

Customer Service
Kundenservice
Service Consommateurs
Servicio Al Consumidor
LEGO.com/service or dial

: 00800 5346 5555
: 1-800-422-5346

Q W E R T Y