

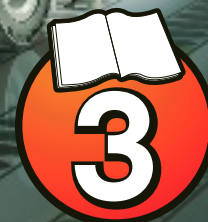

TECHNIC

8109

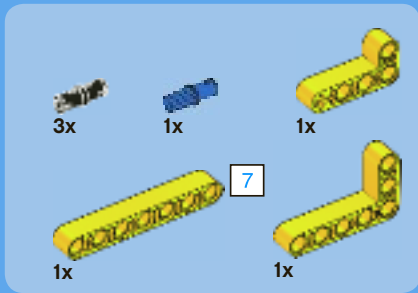



76

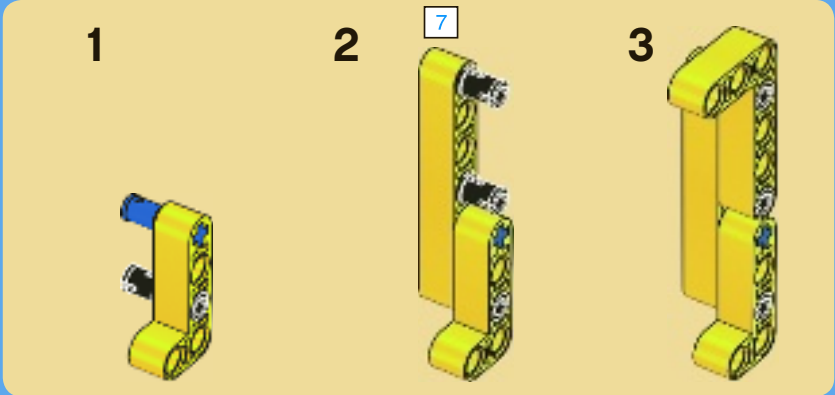
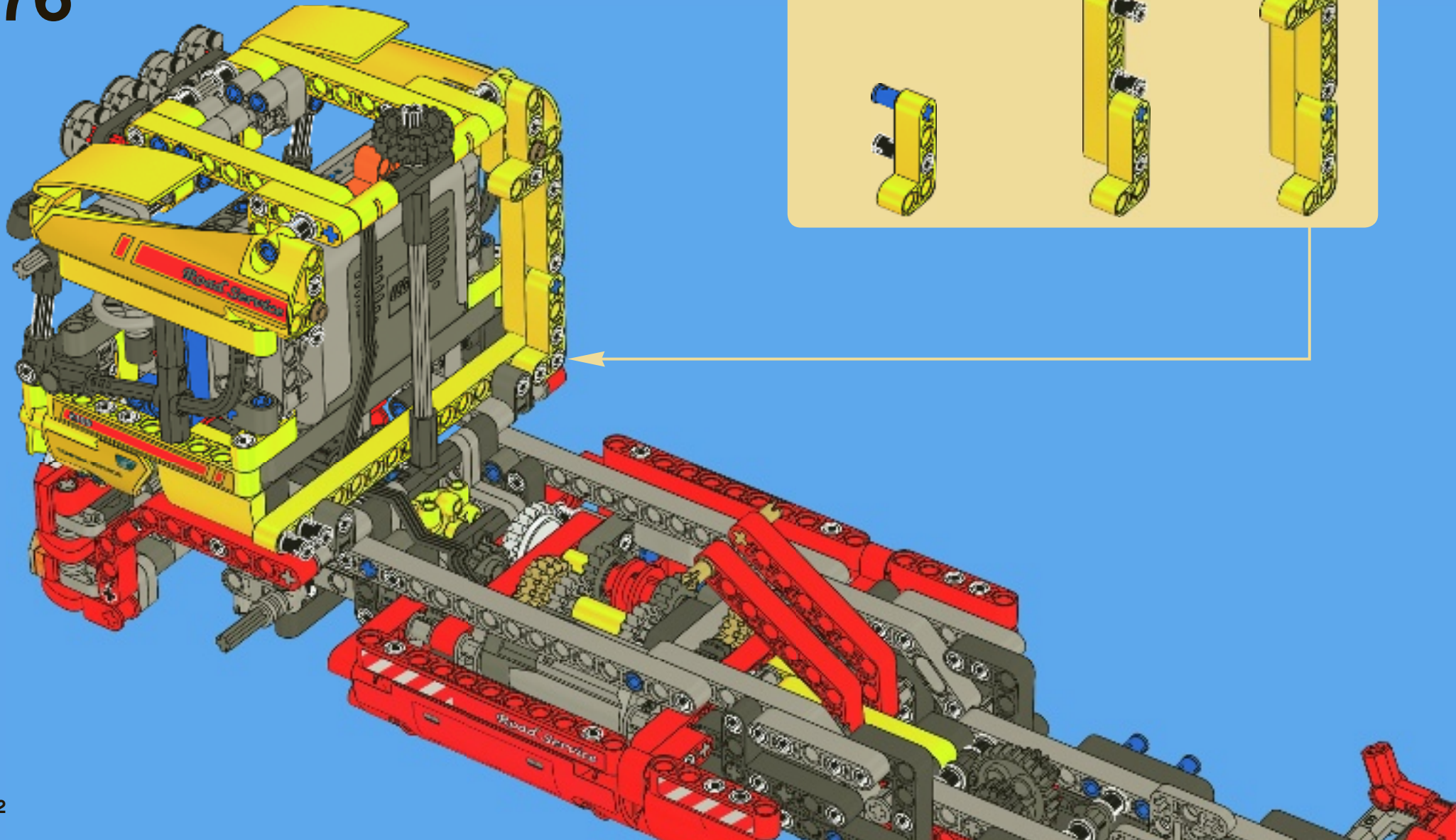

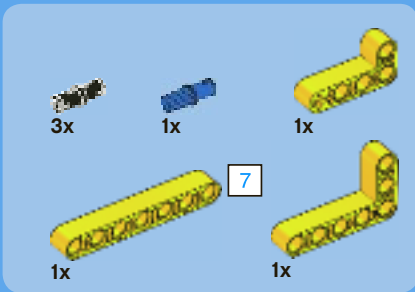

77

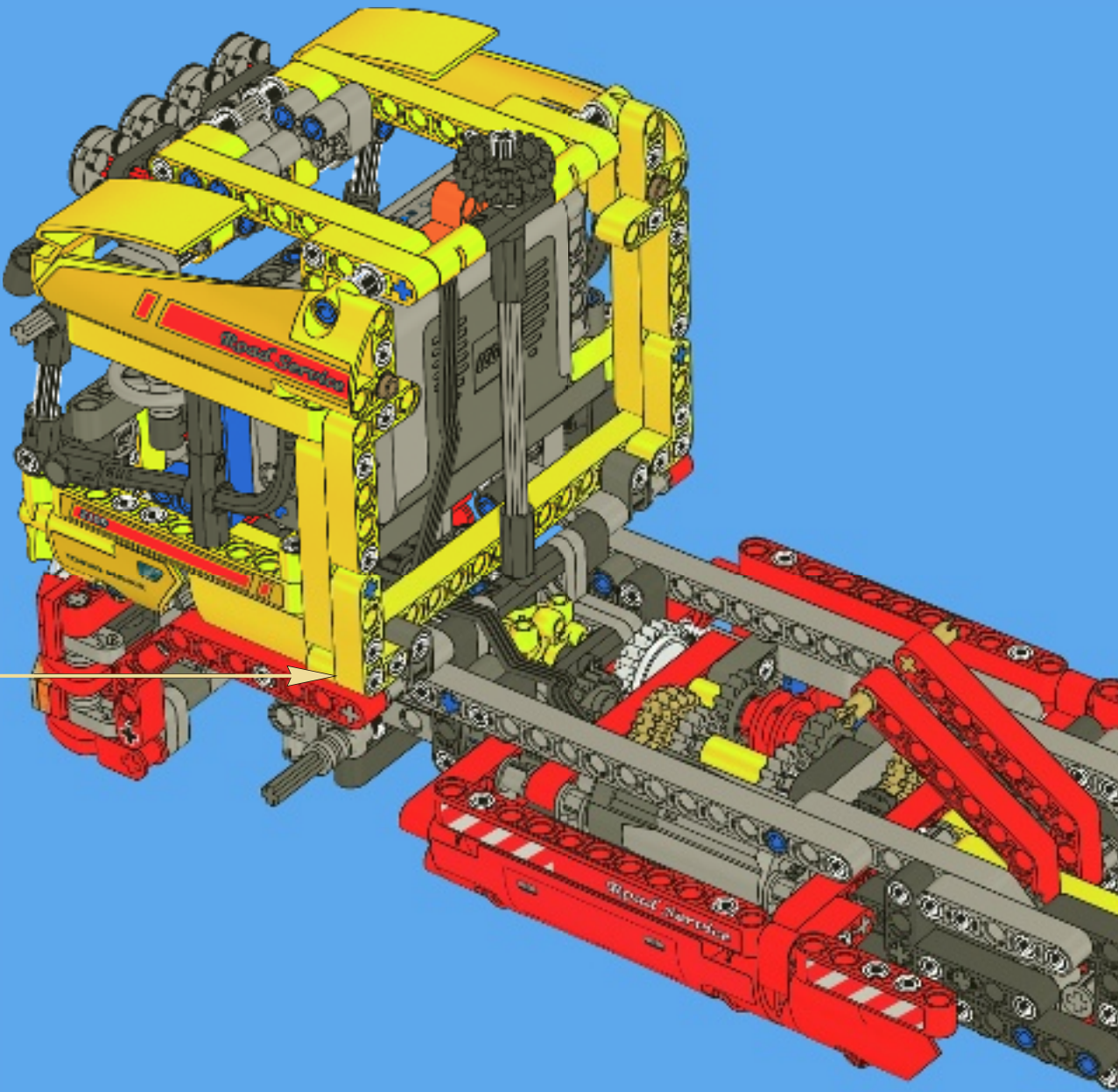
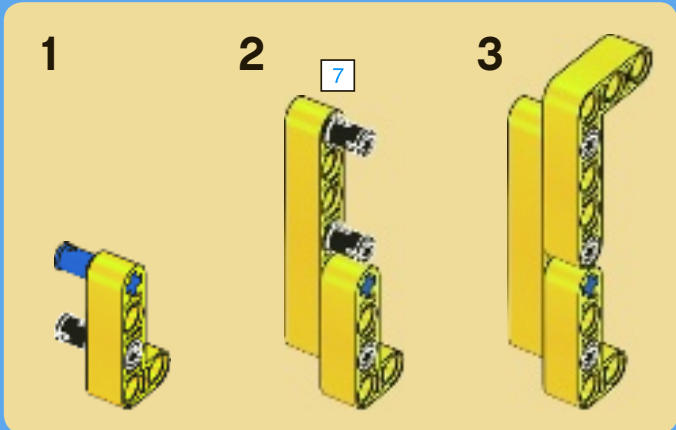

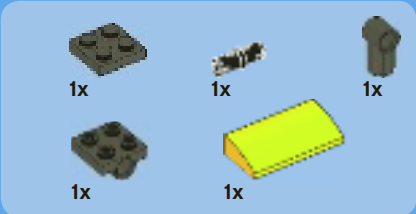

1

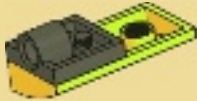

2

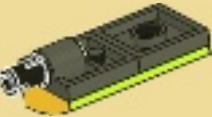

3

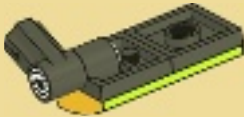

78

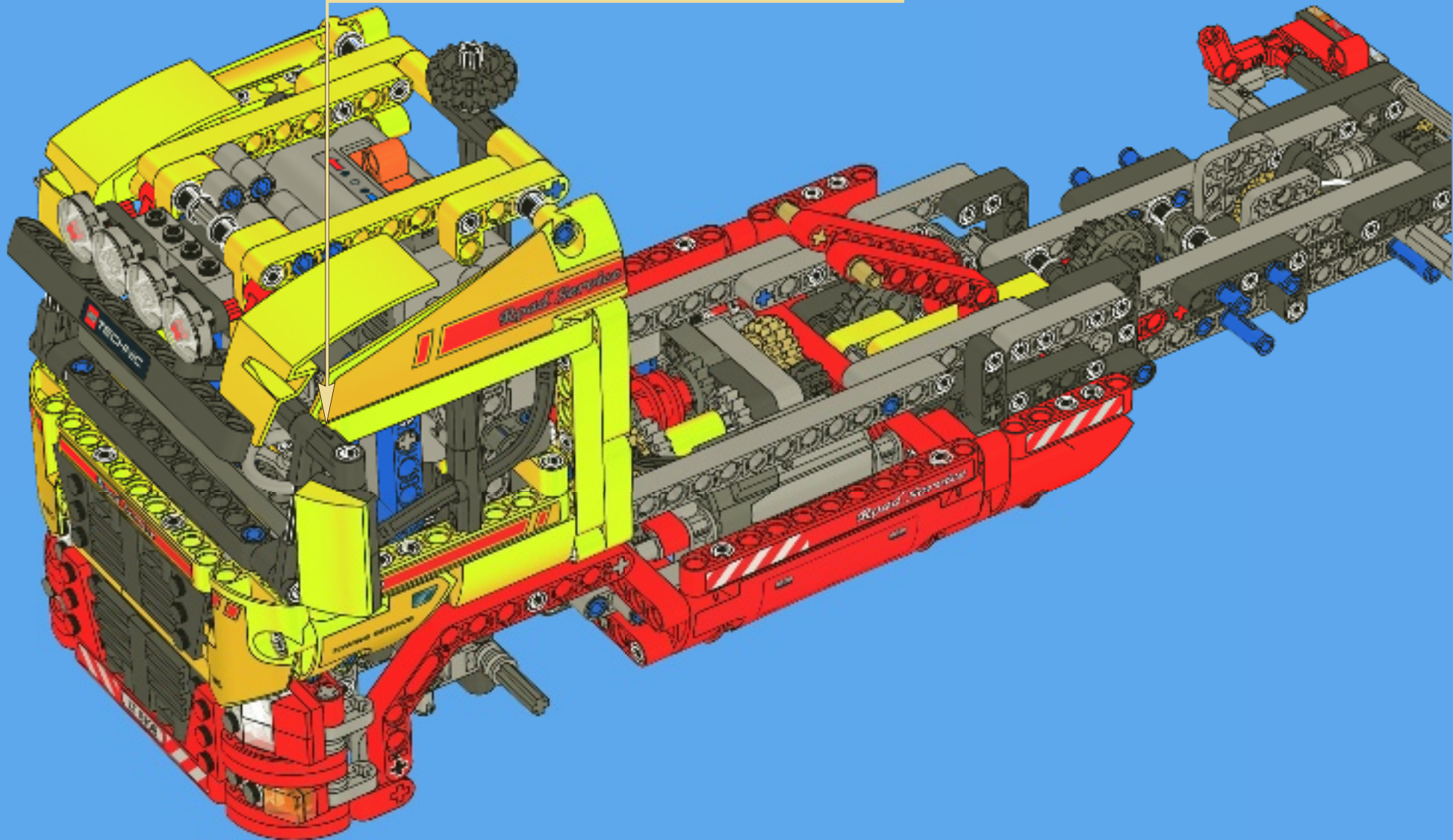

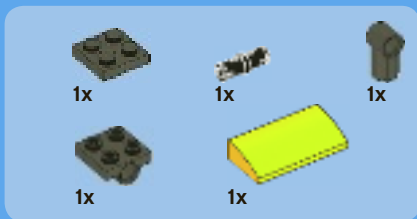

79

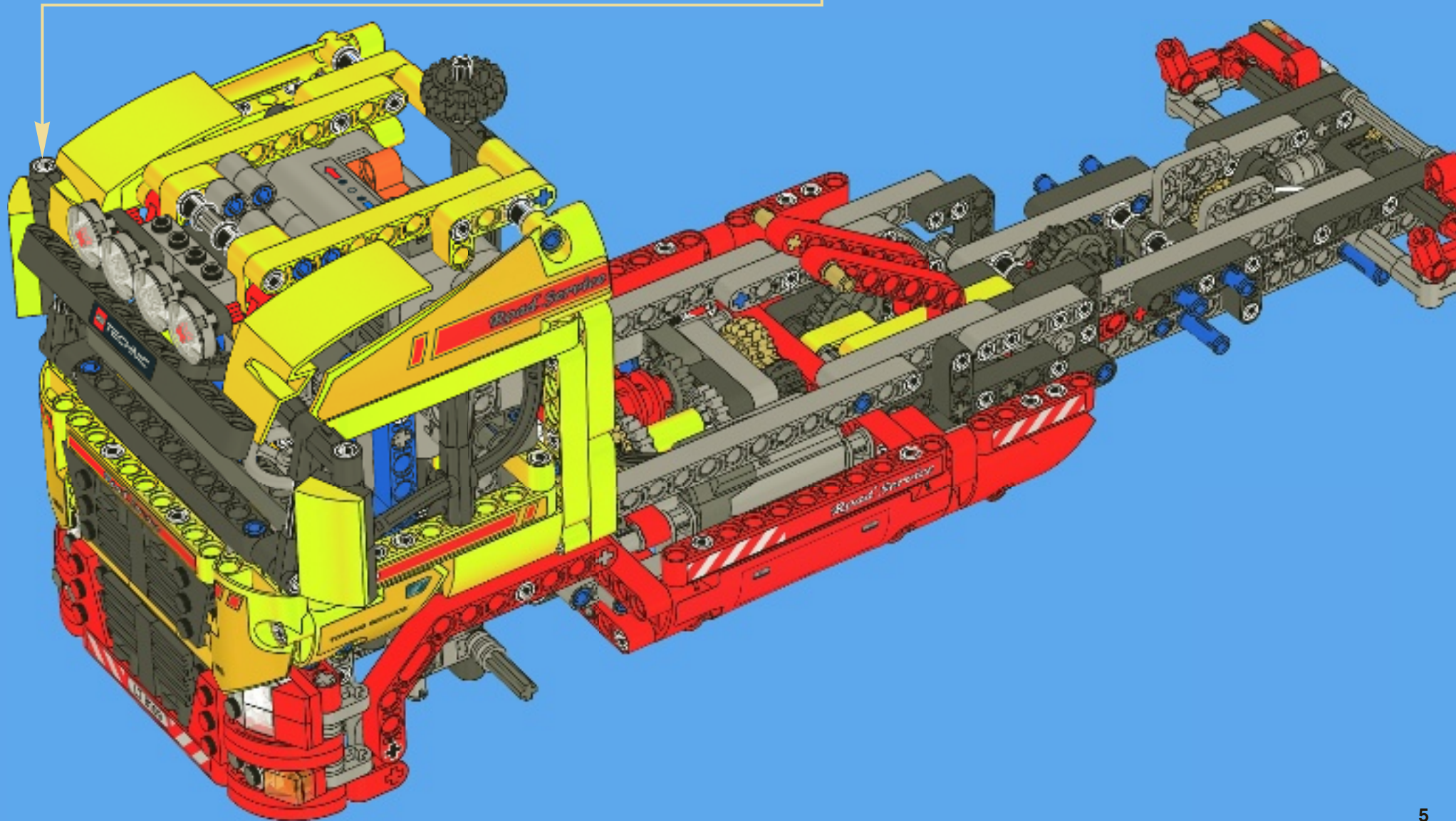

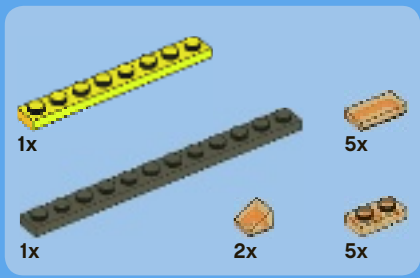

80

1

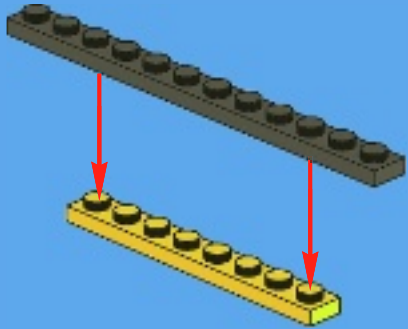

2

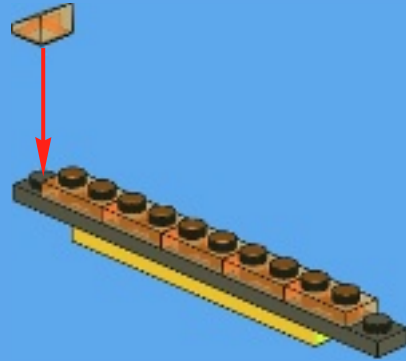

3

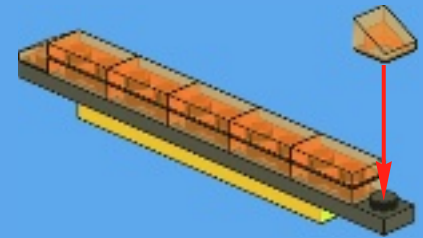

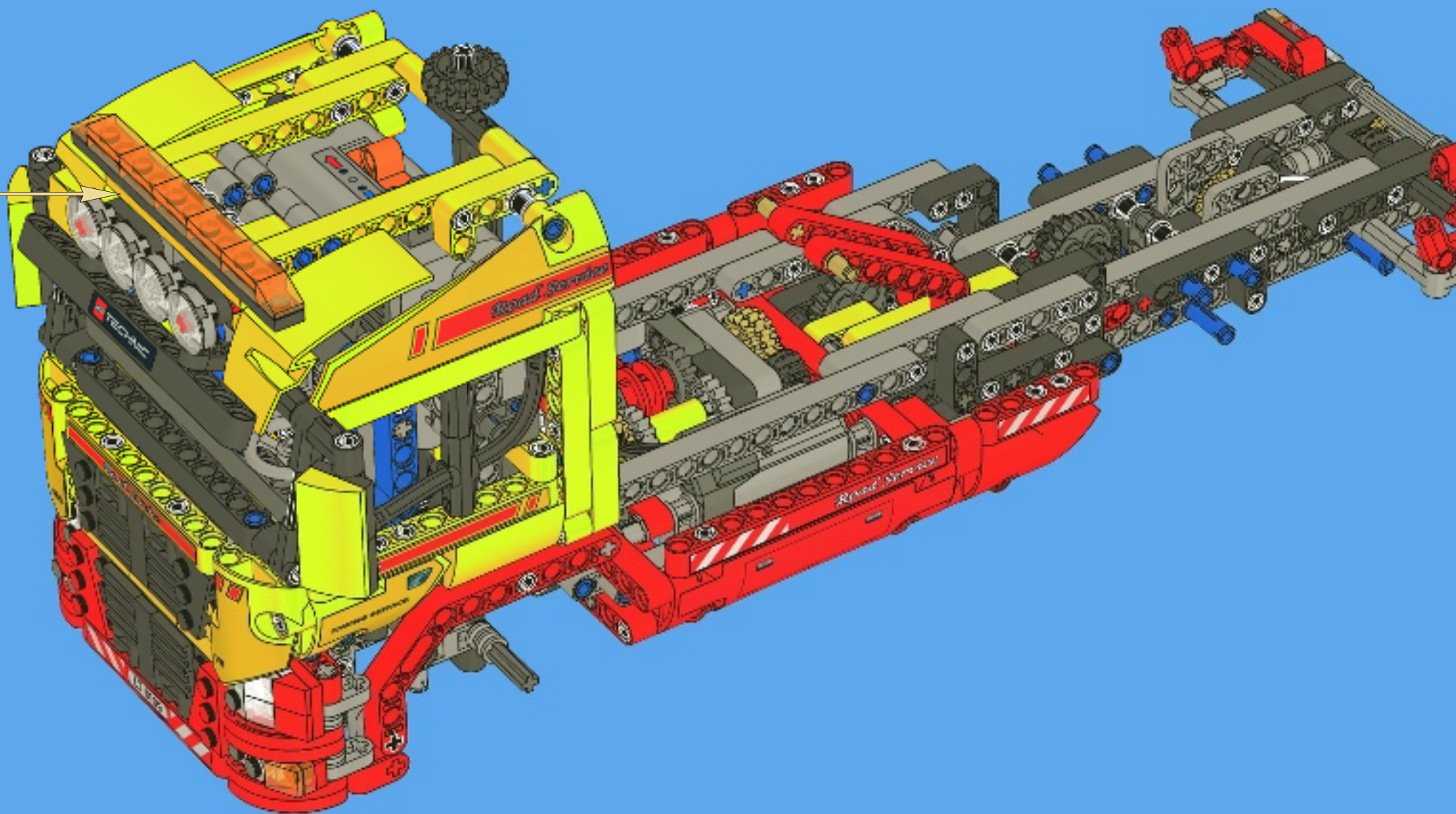

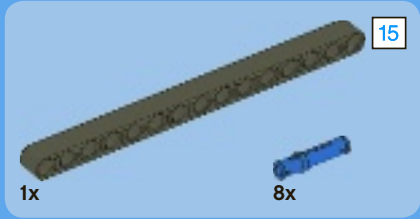
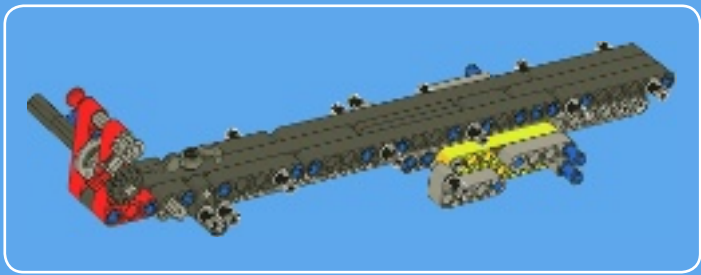

1

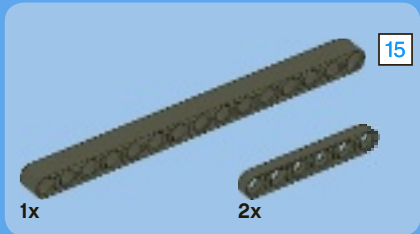
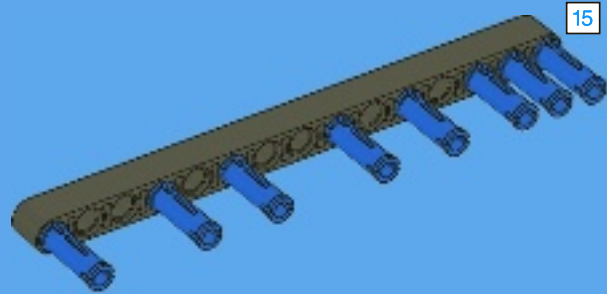

2

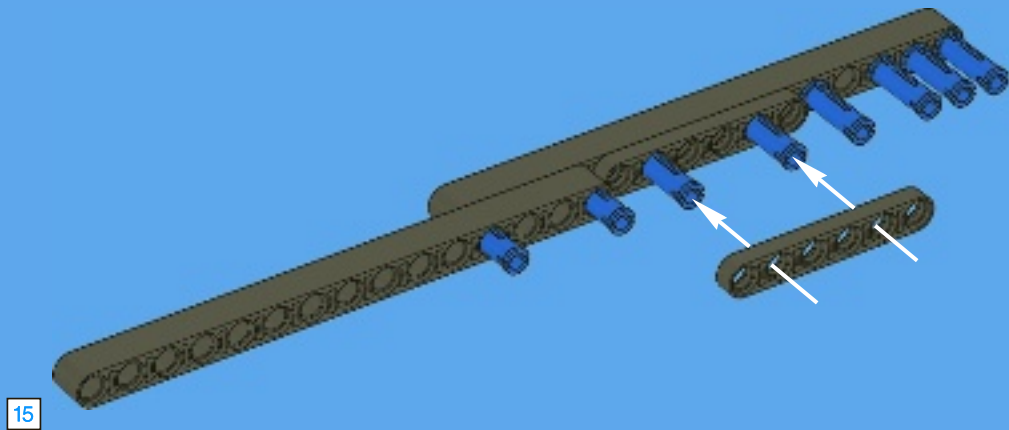

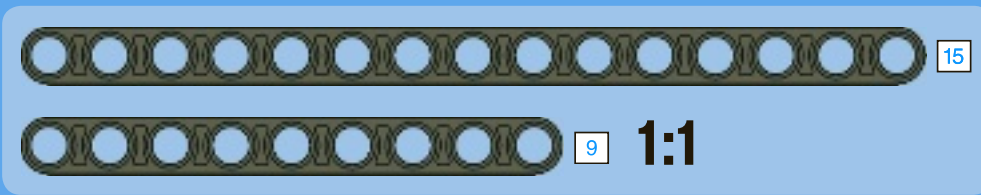
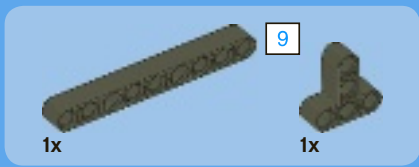

3

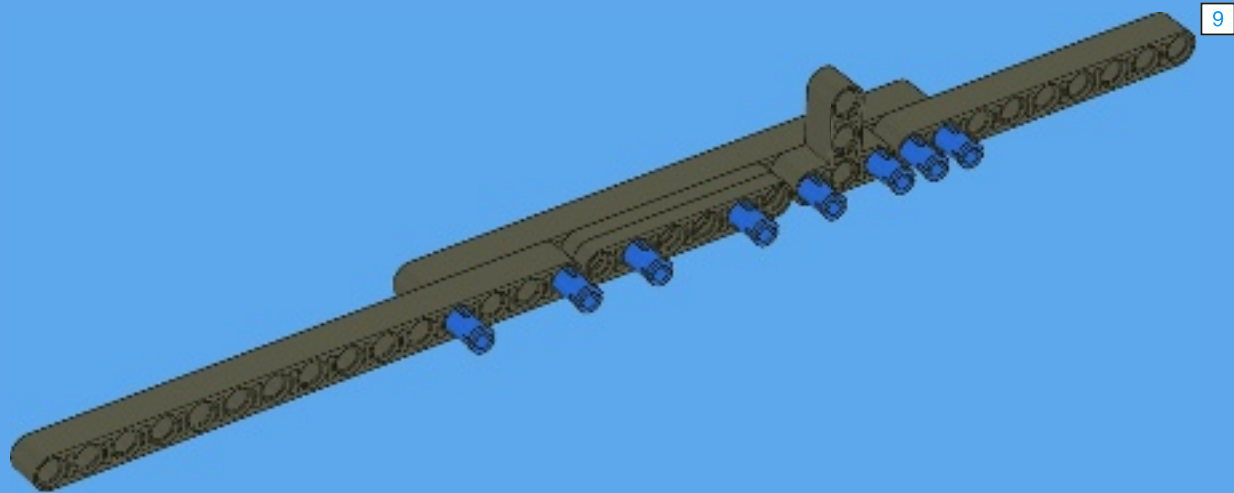

4

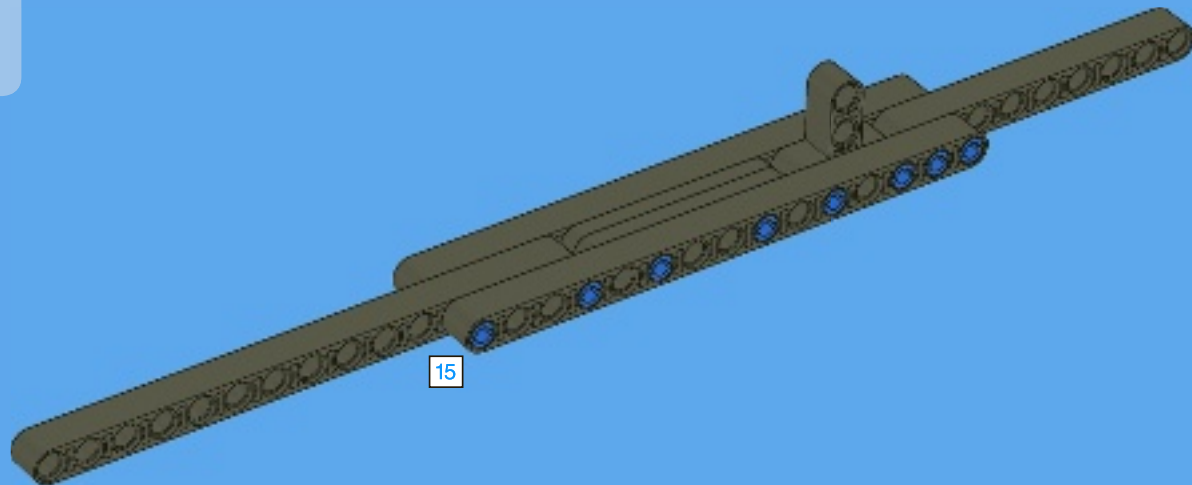



7x

5

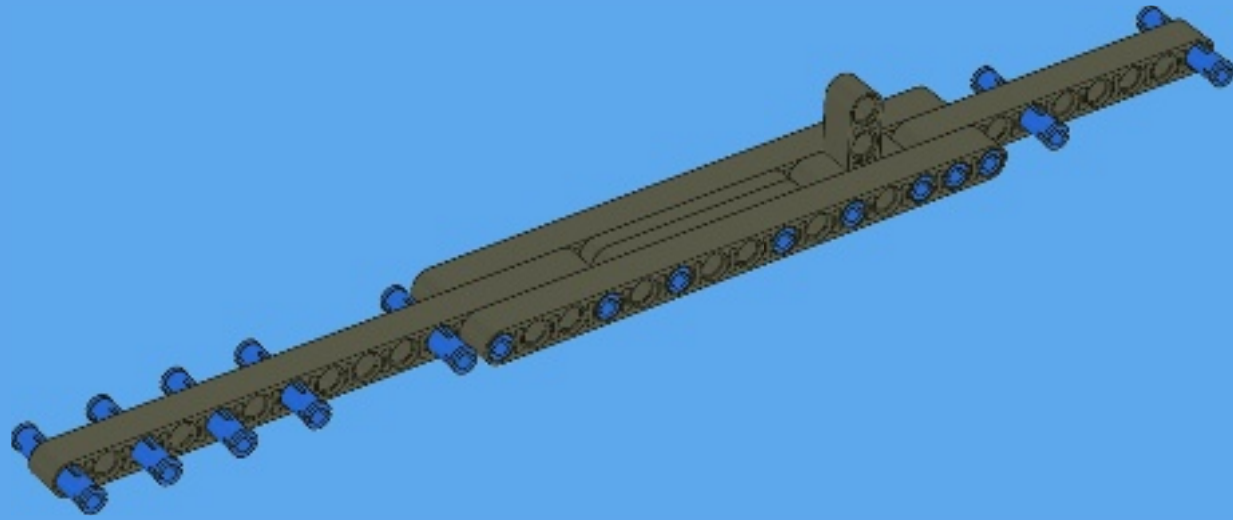

1x



2x

7



7

1:1

6

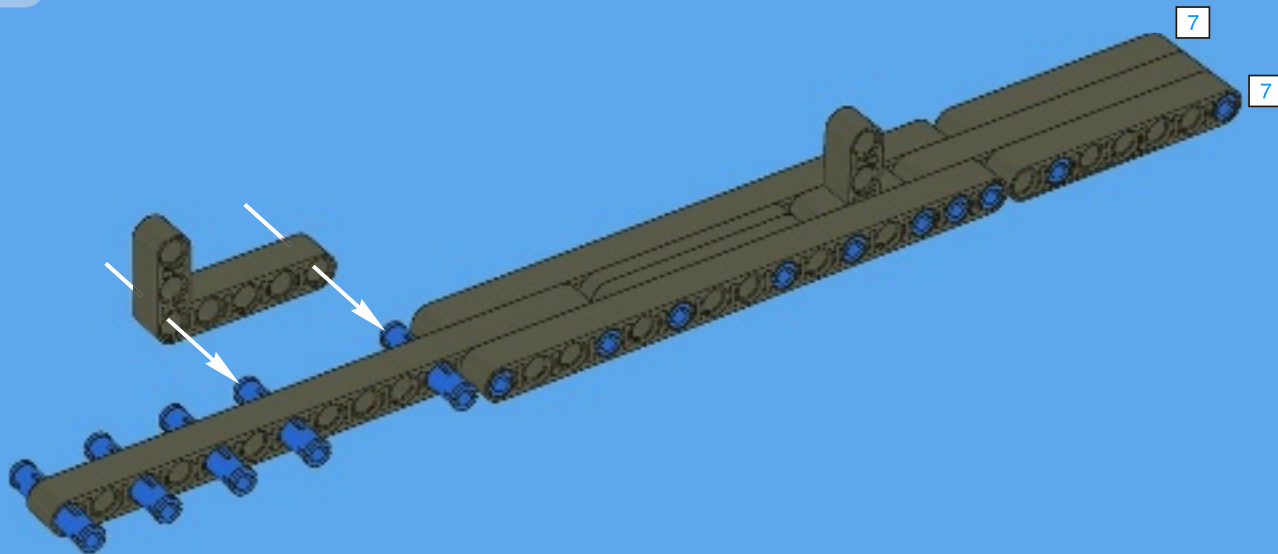



8x

7

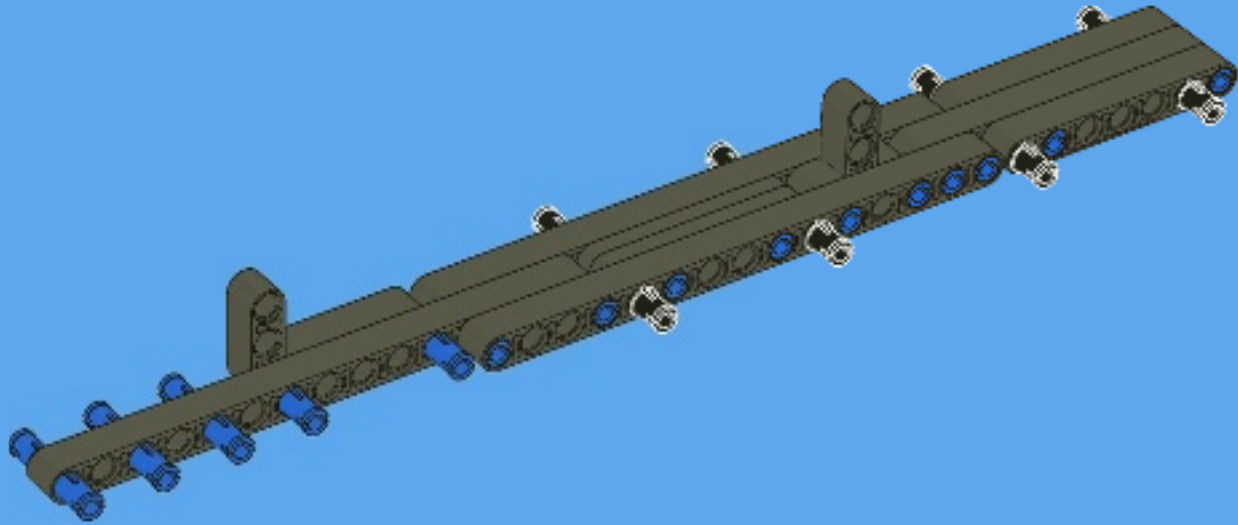

1x



2x



3

1:1

8

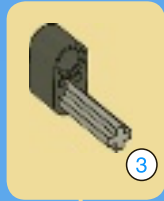

3

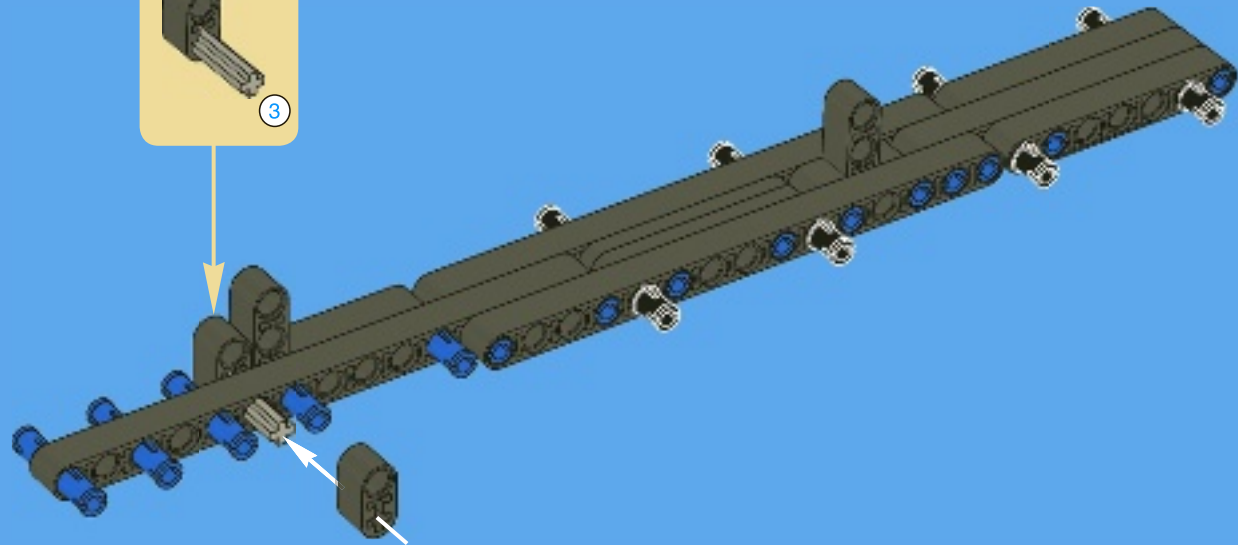



2x

9

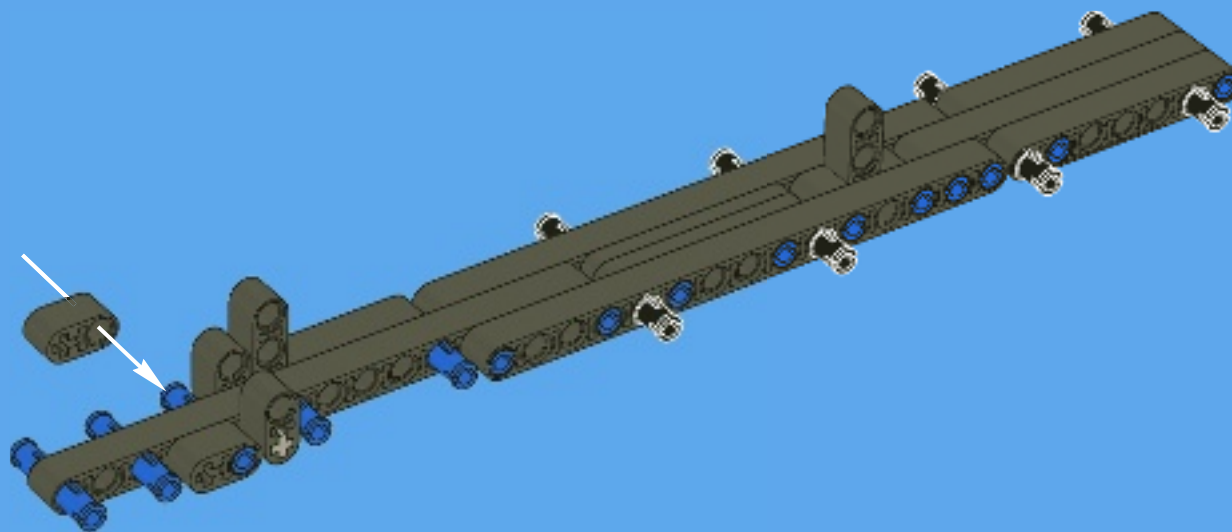

1x

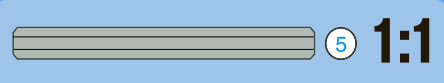

5 1:1

10

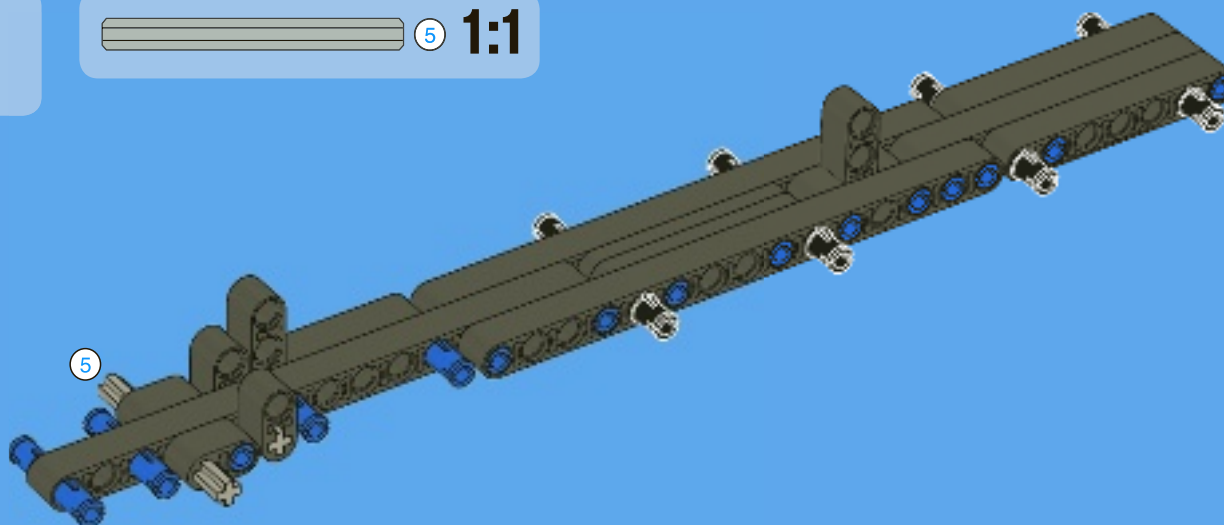

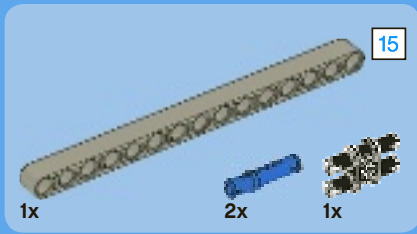
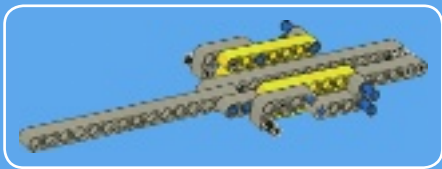

1

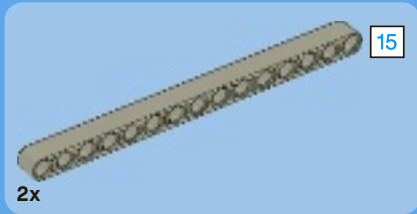
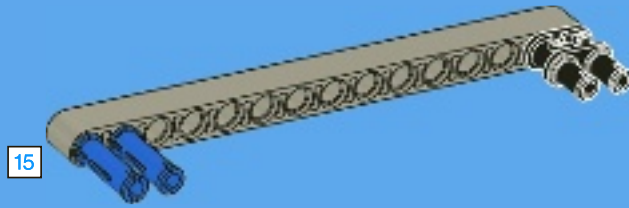

2

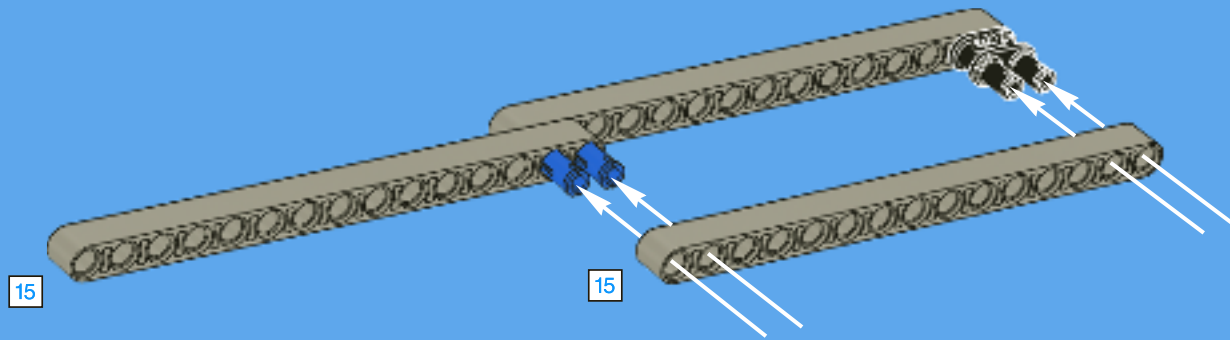

3

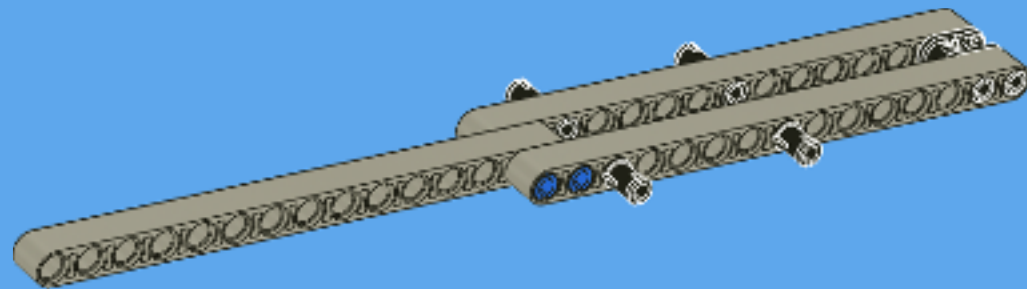

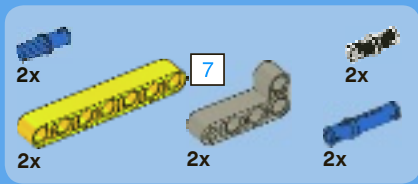

4

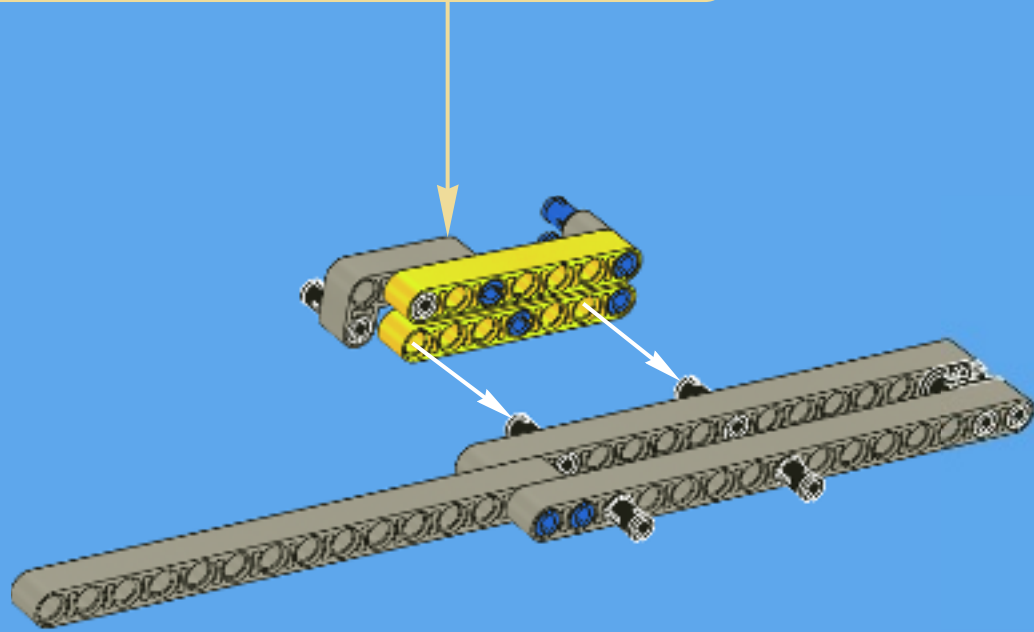

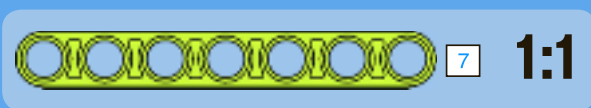
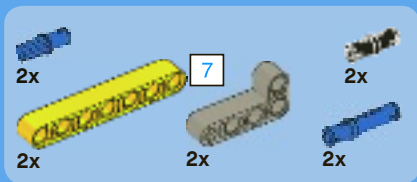

5

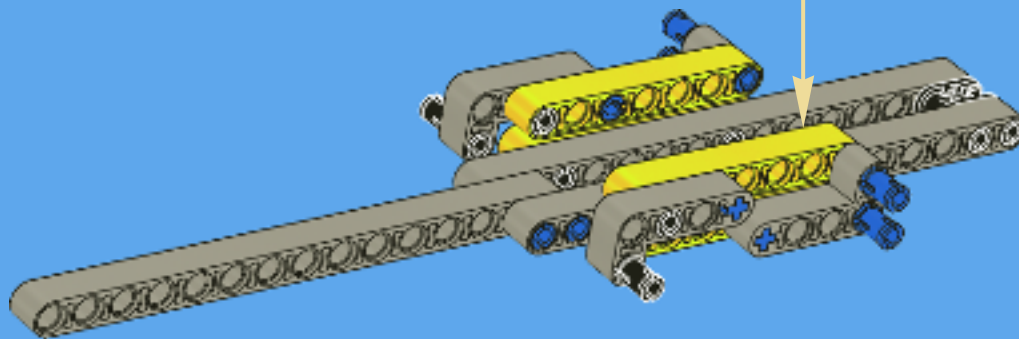
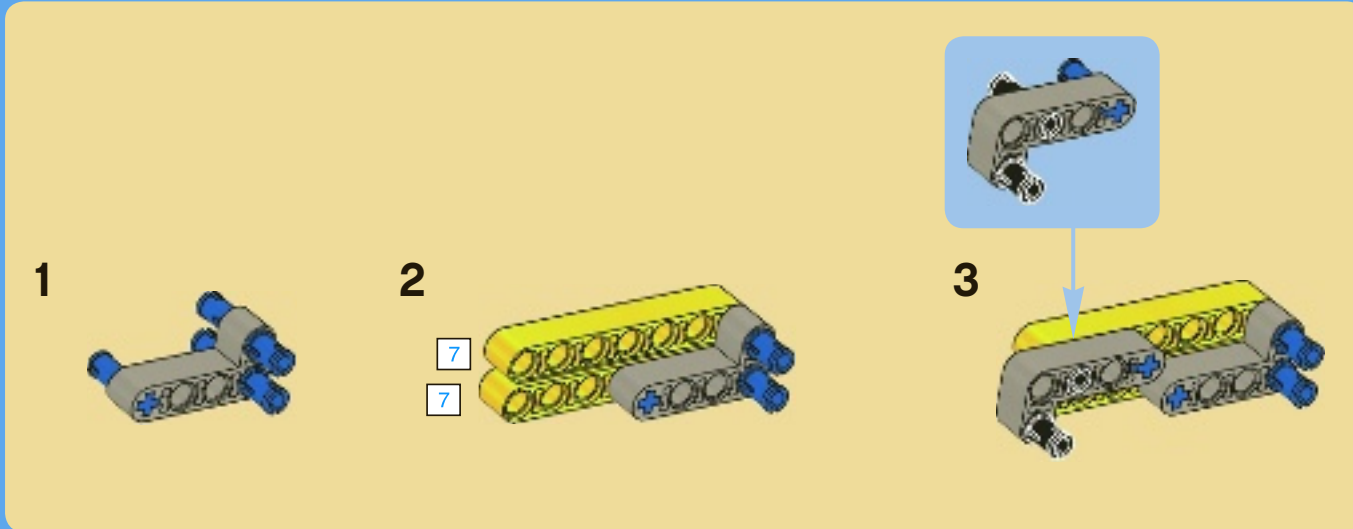

11

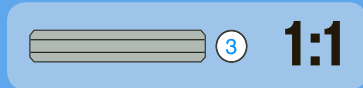
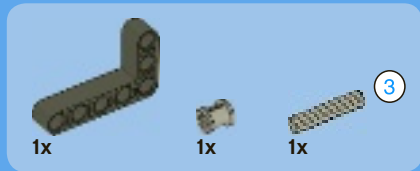
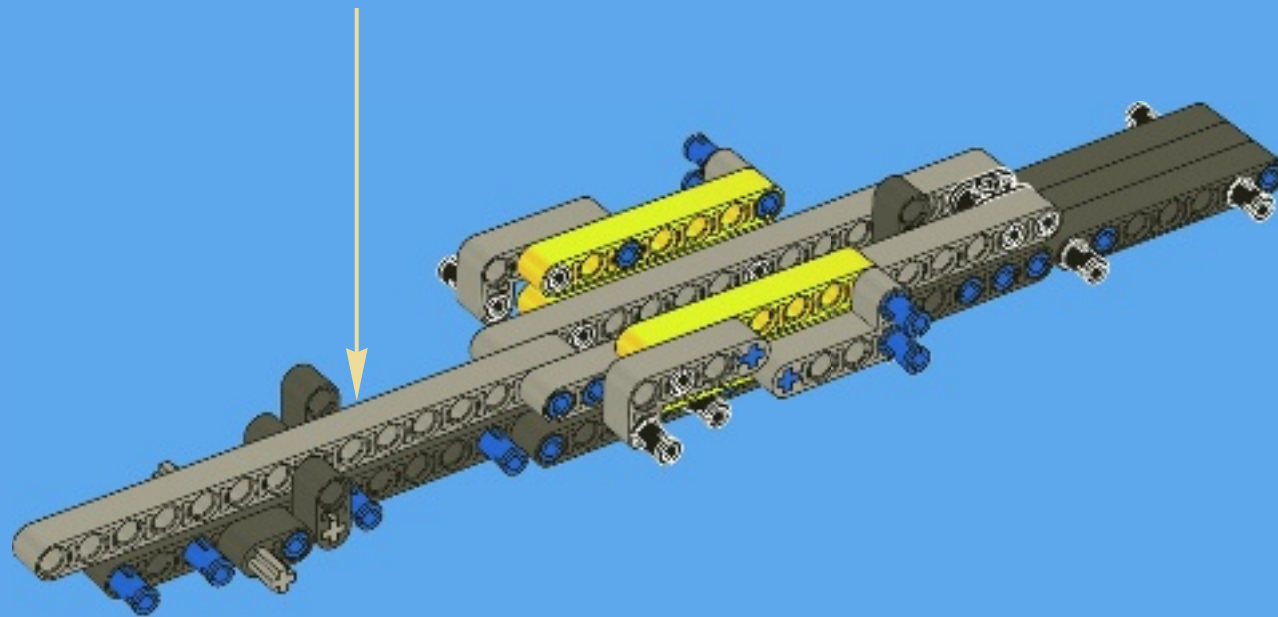

12

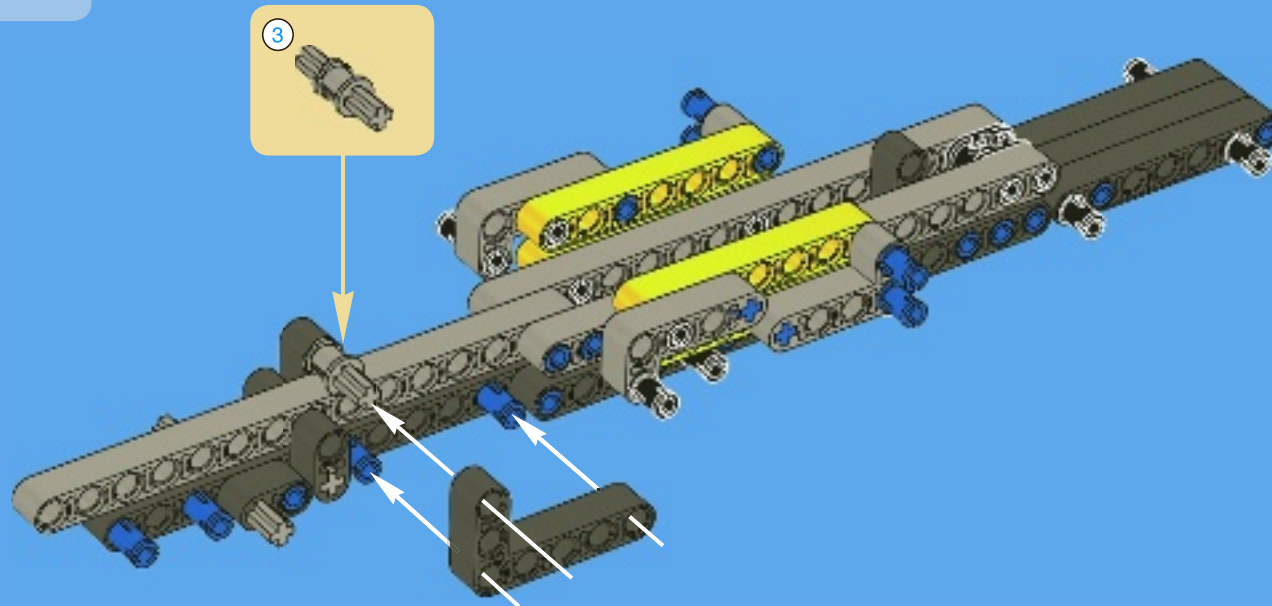



3x

13

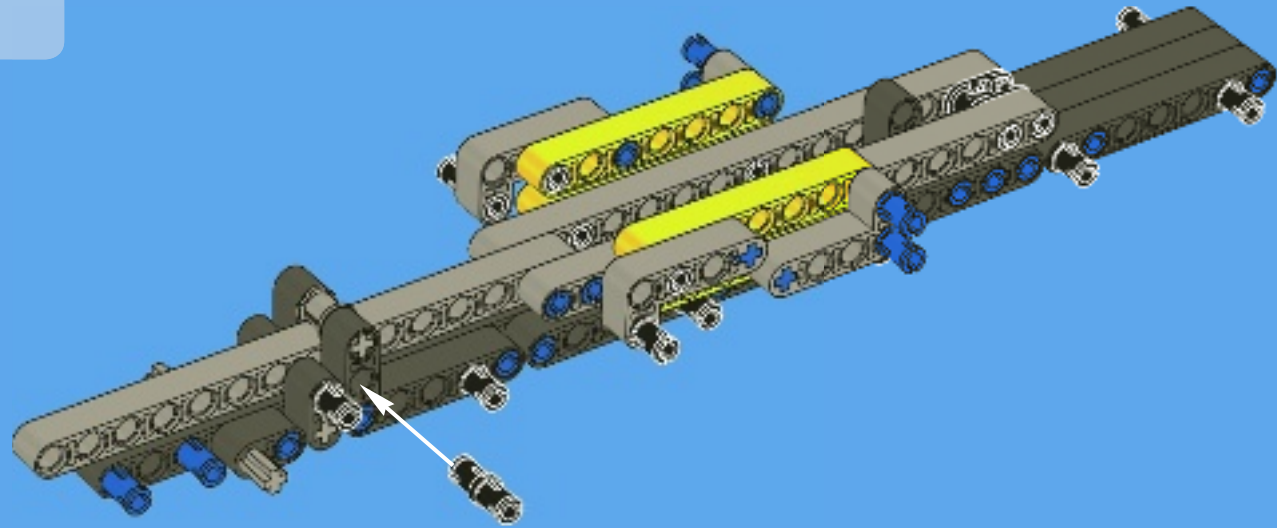

1x



2x

14

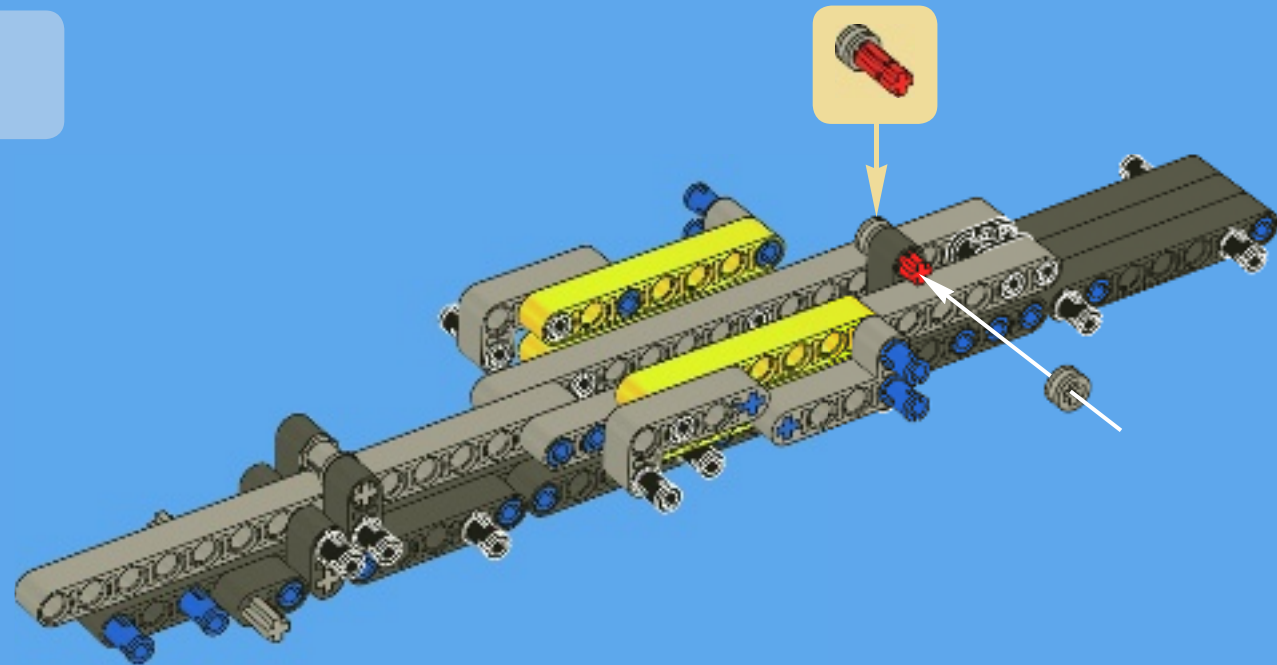

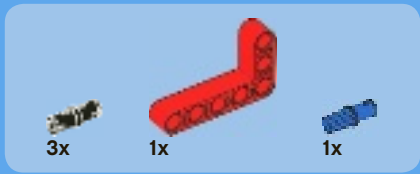

15

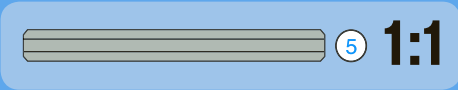
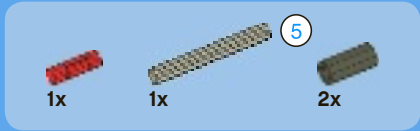
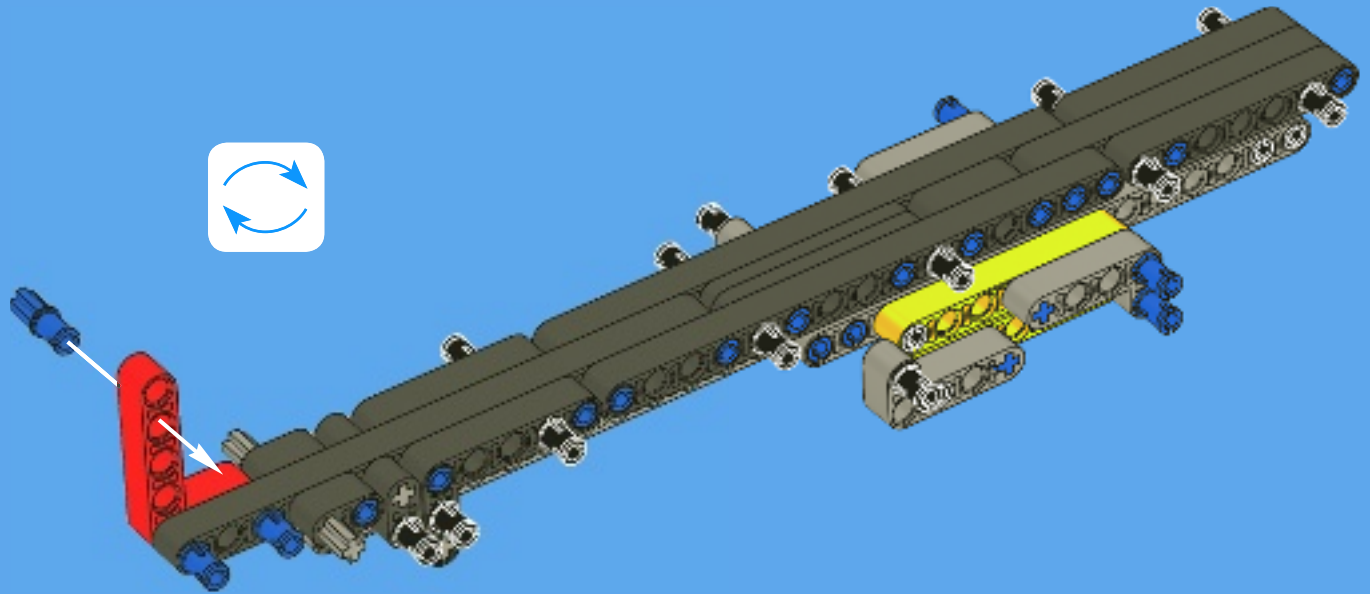

16

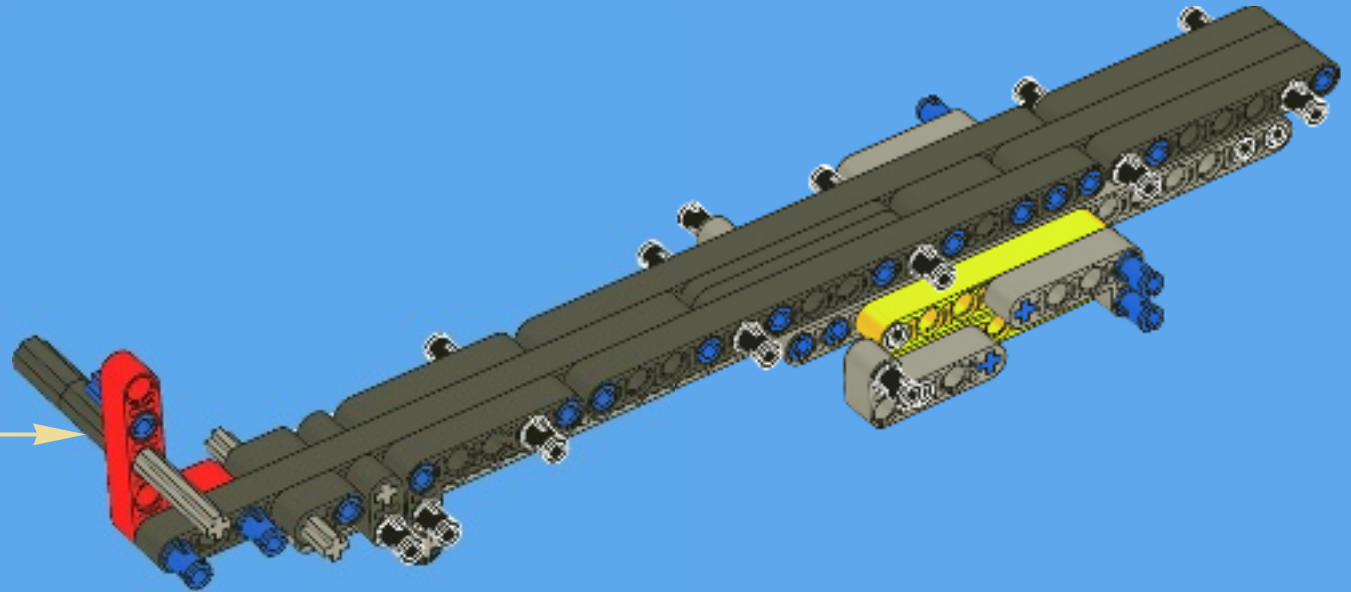
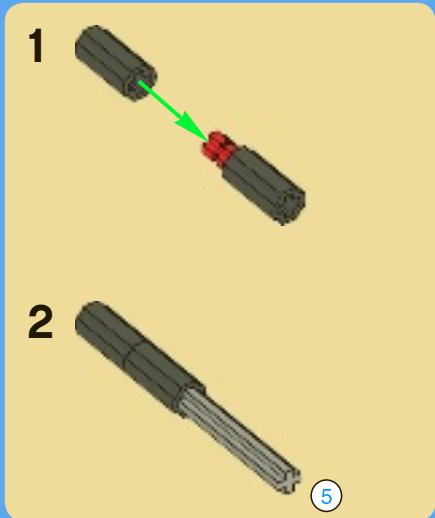

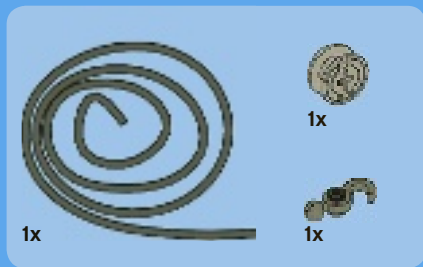

17

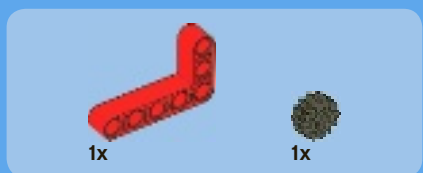
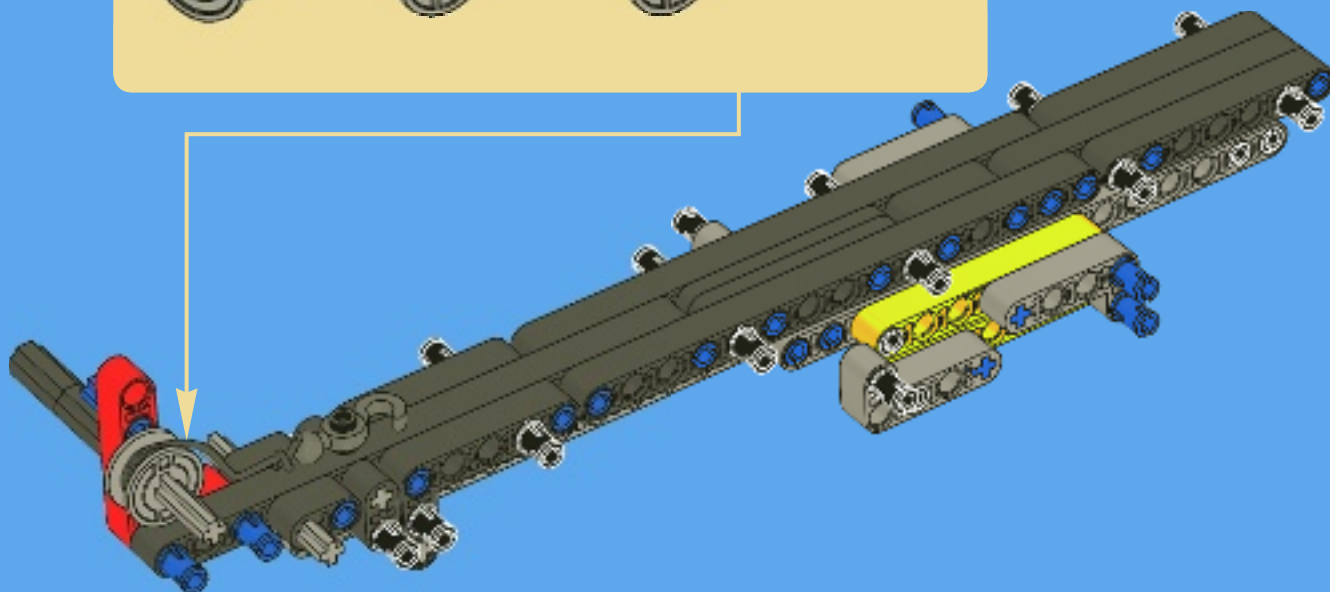

18

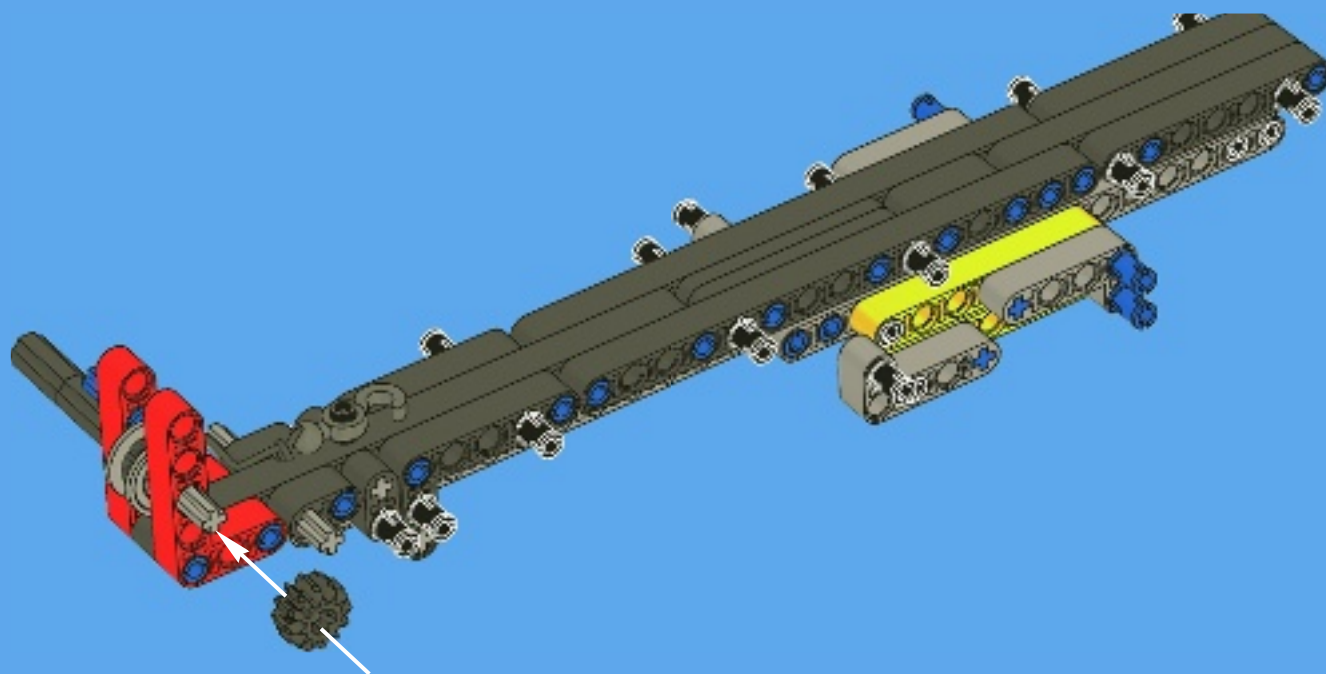

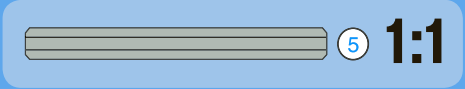
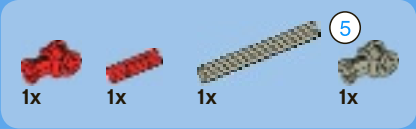

19

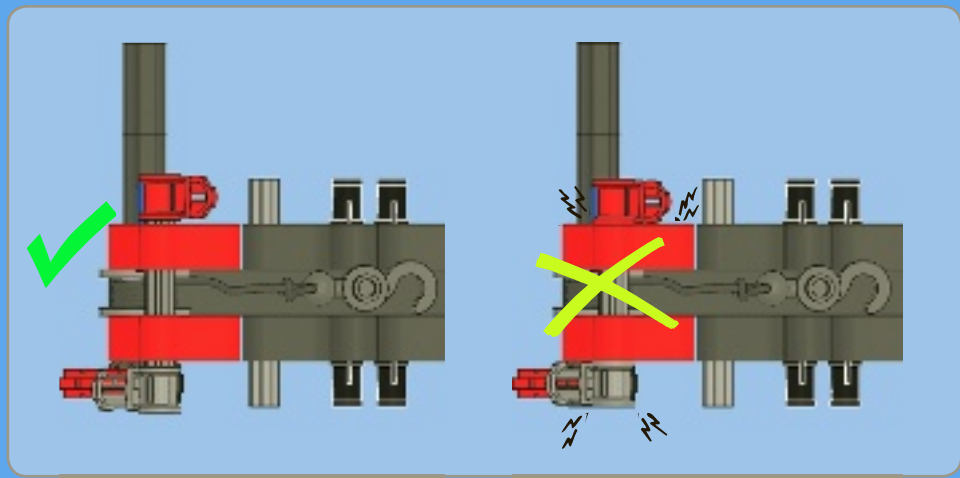
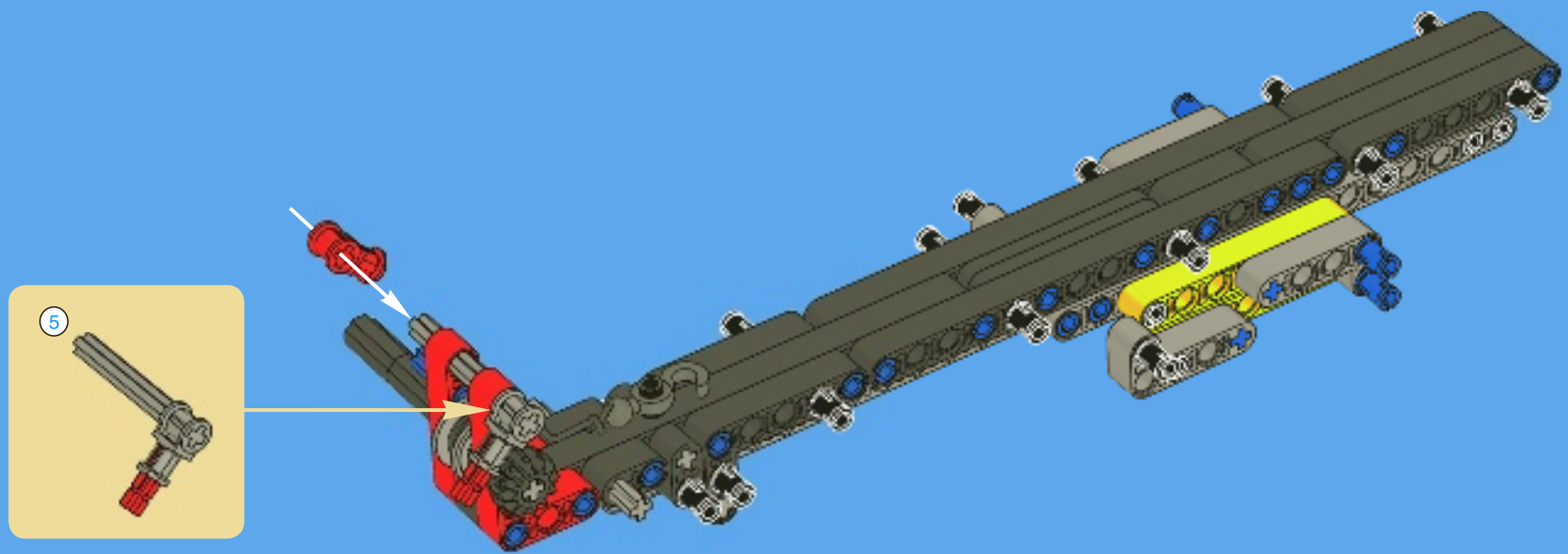



2x

81

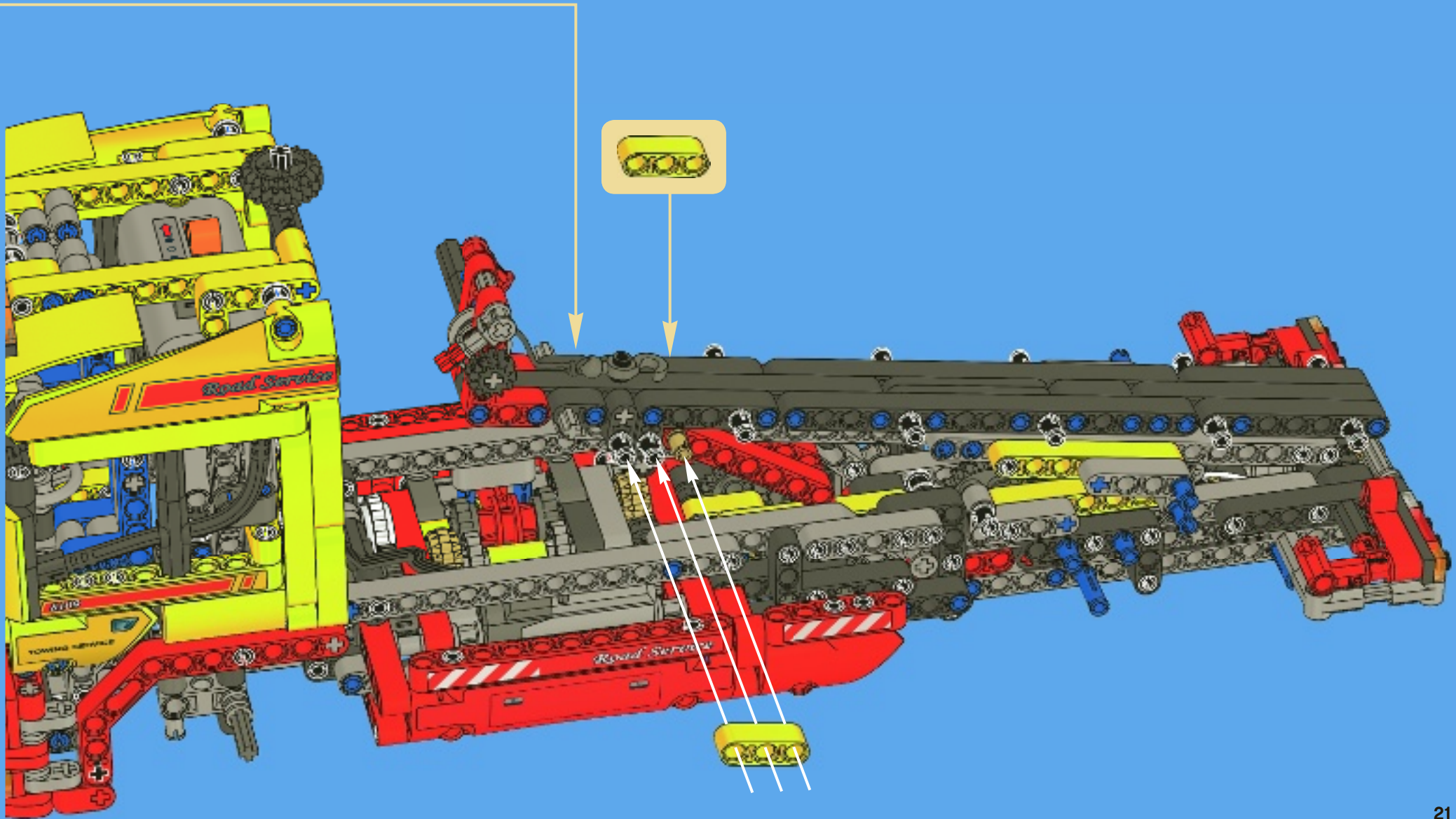

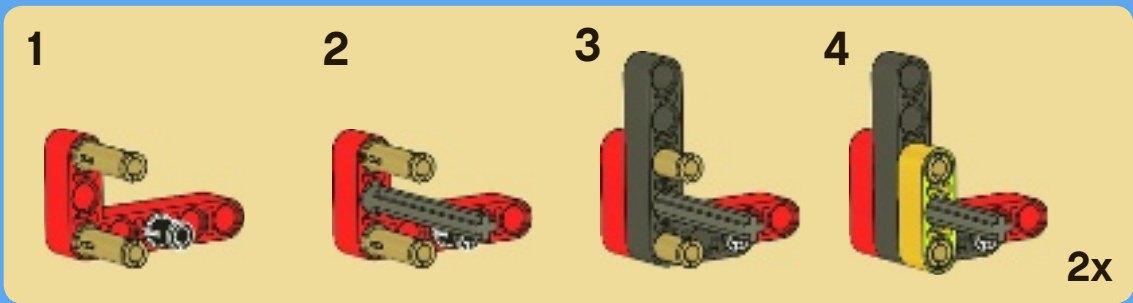
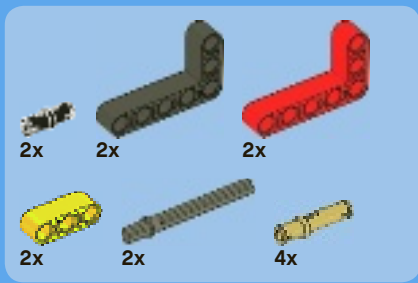

82

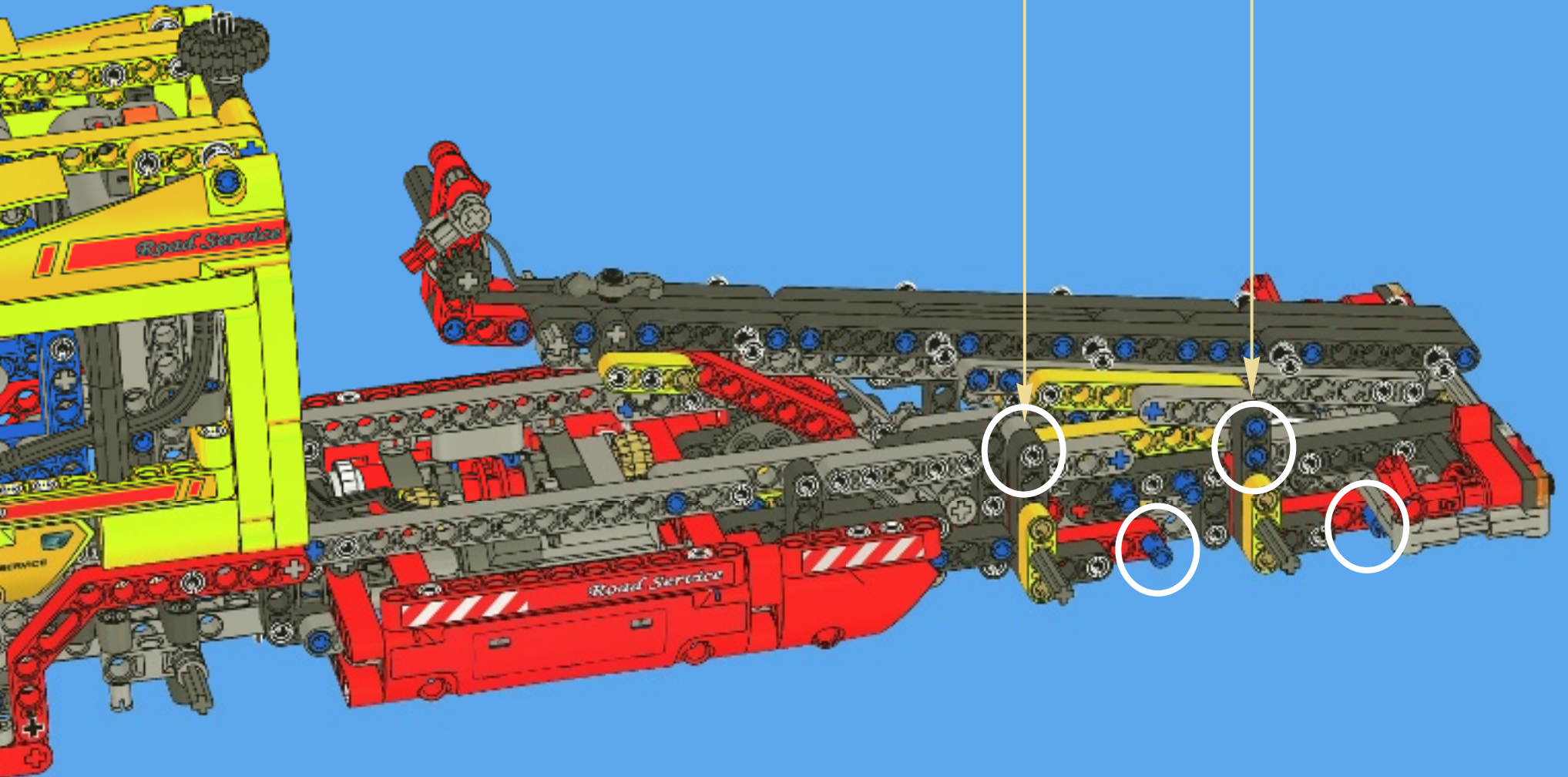

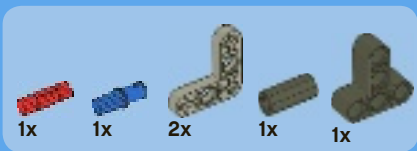

83

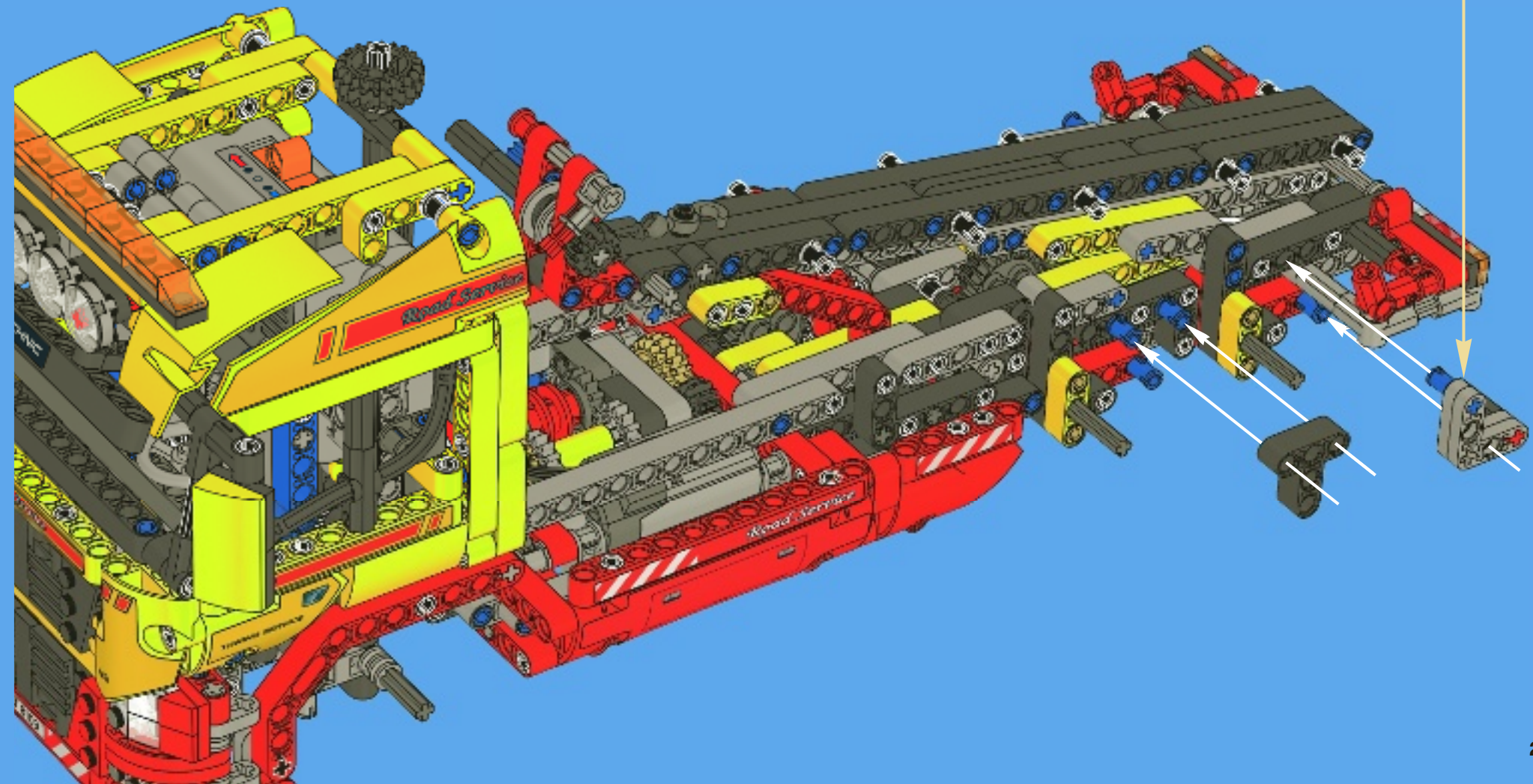
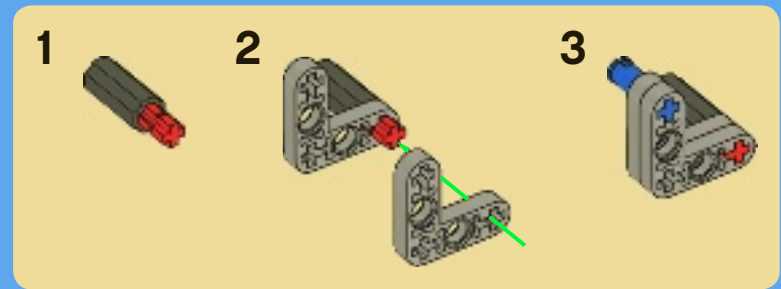

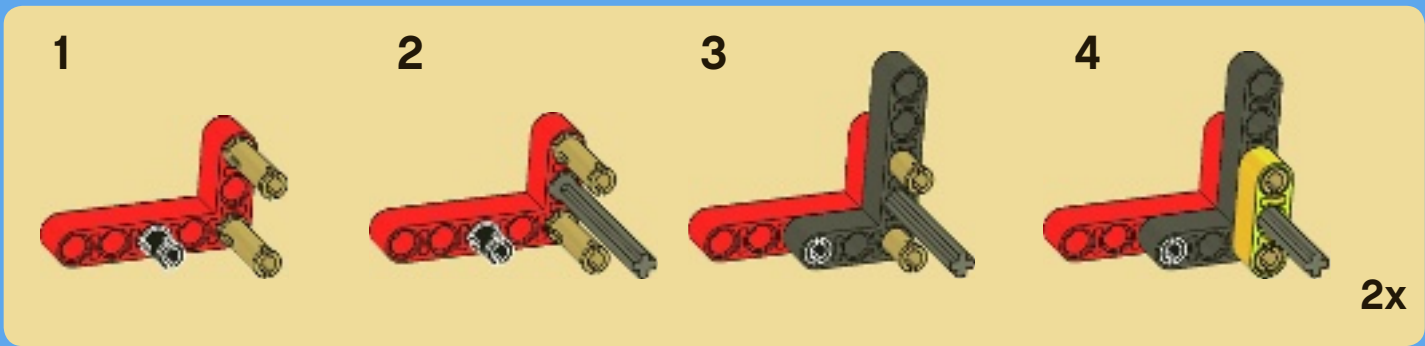
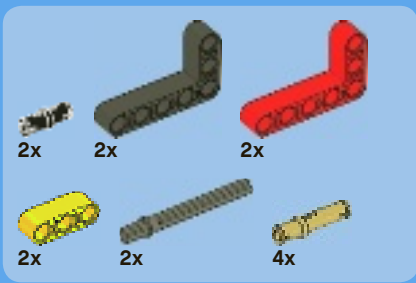

84

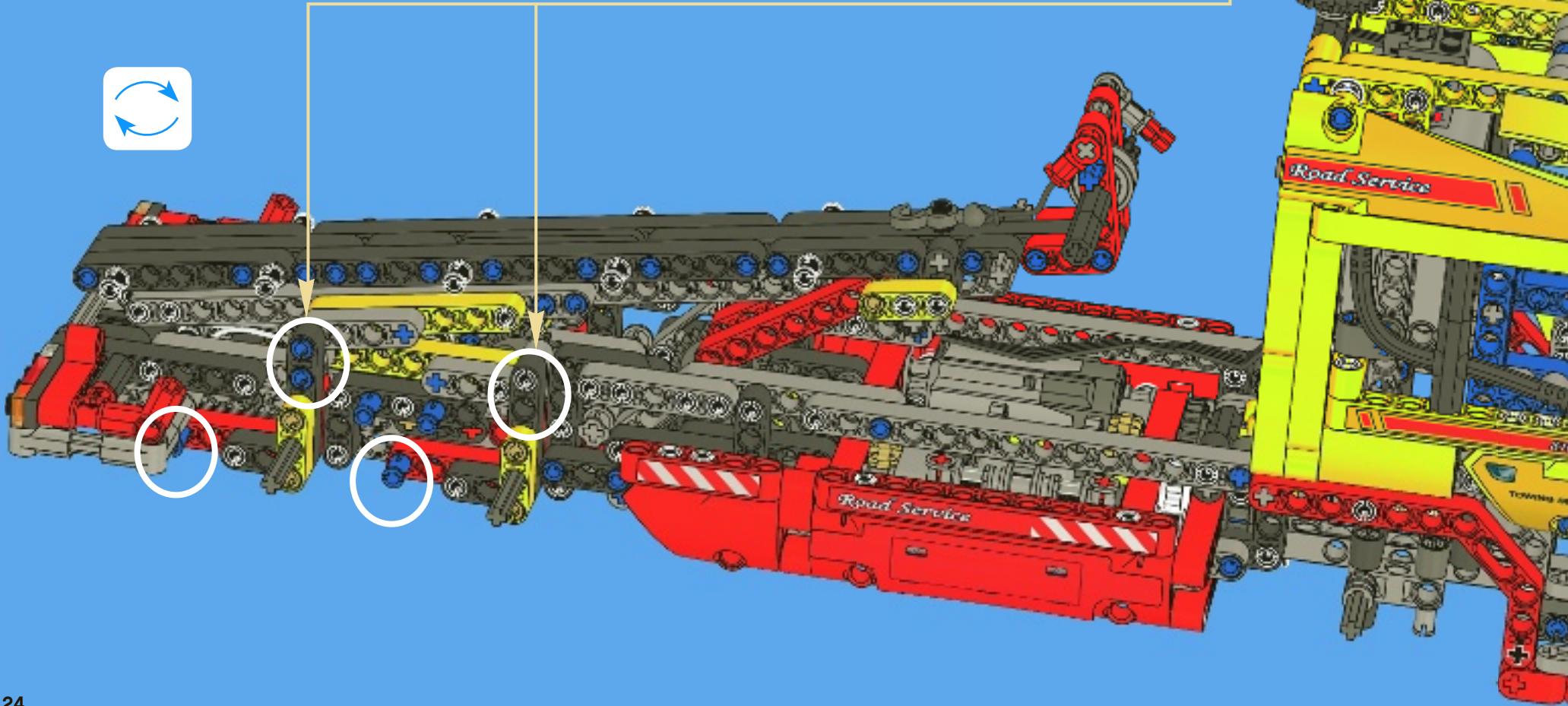

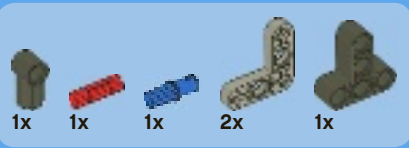

85

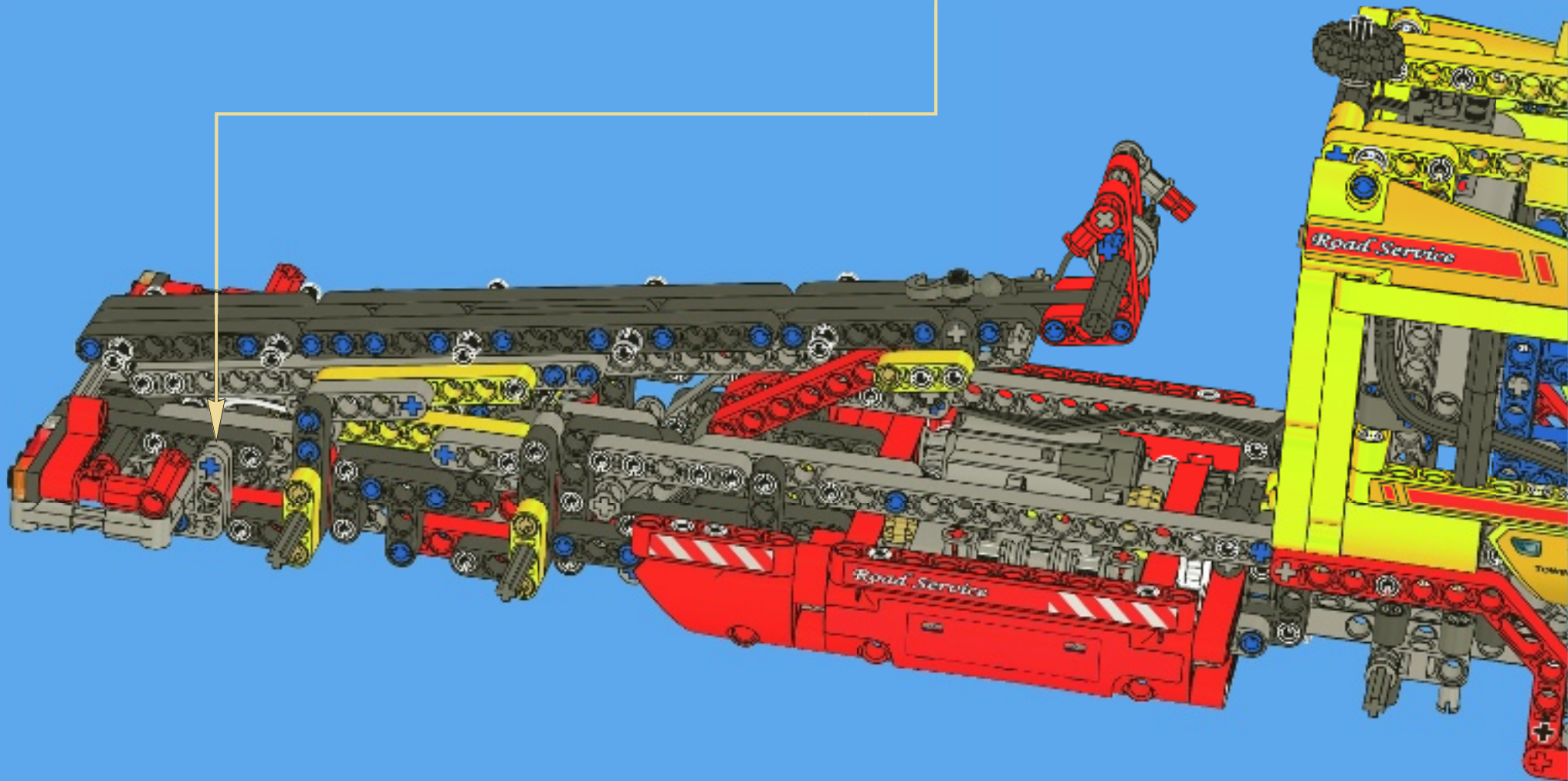
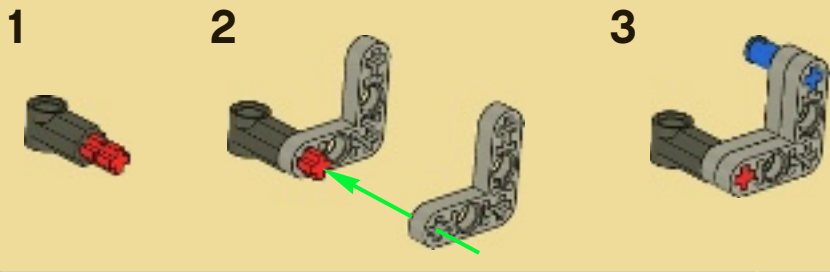

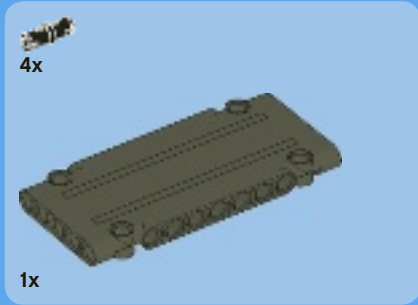
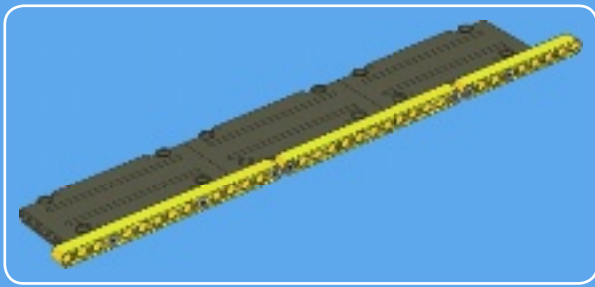

1

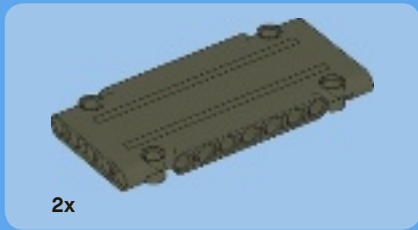
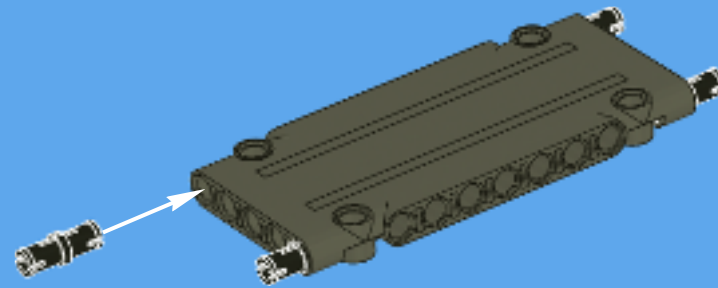

2

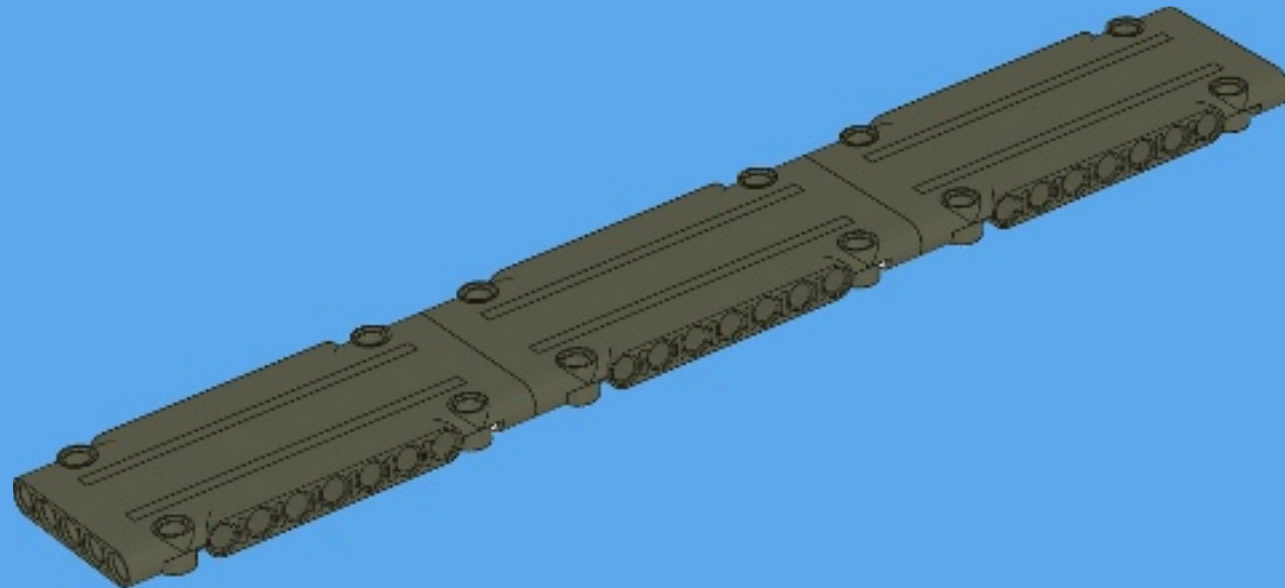

86

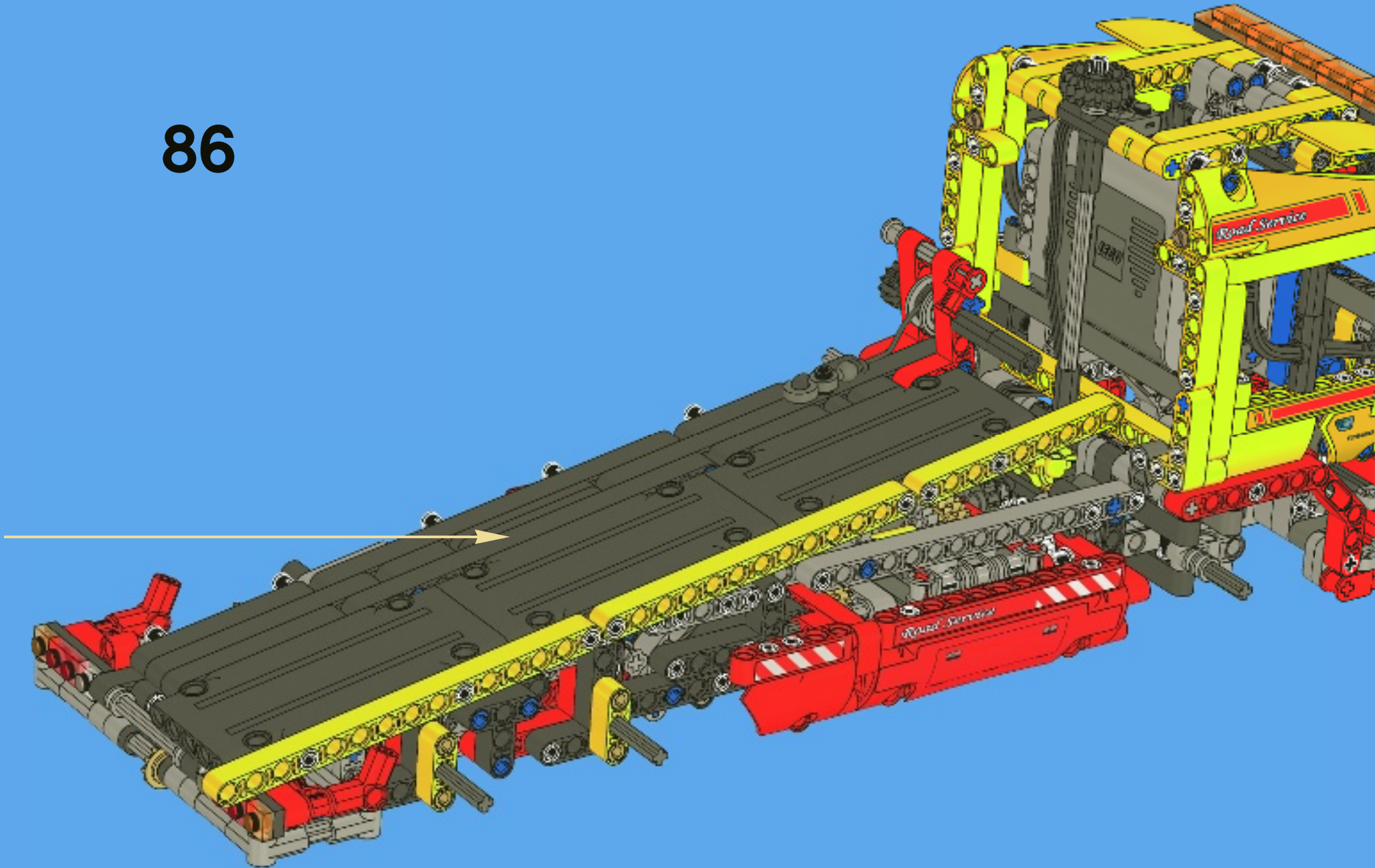

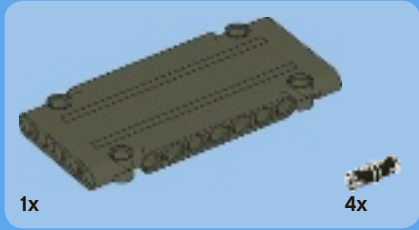
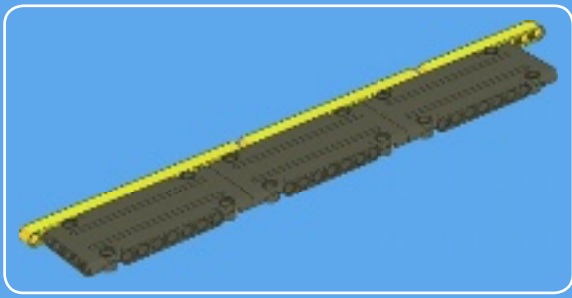

1

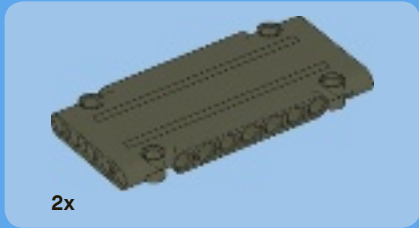
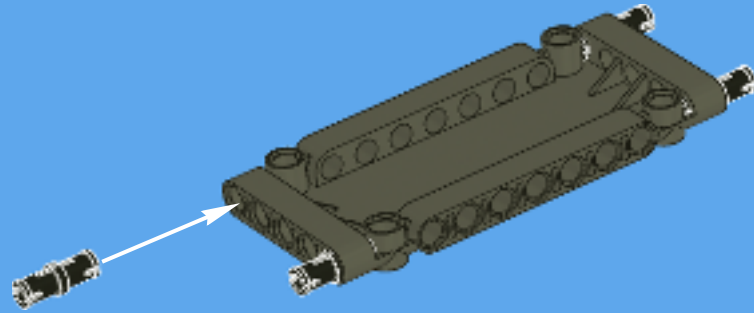

2

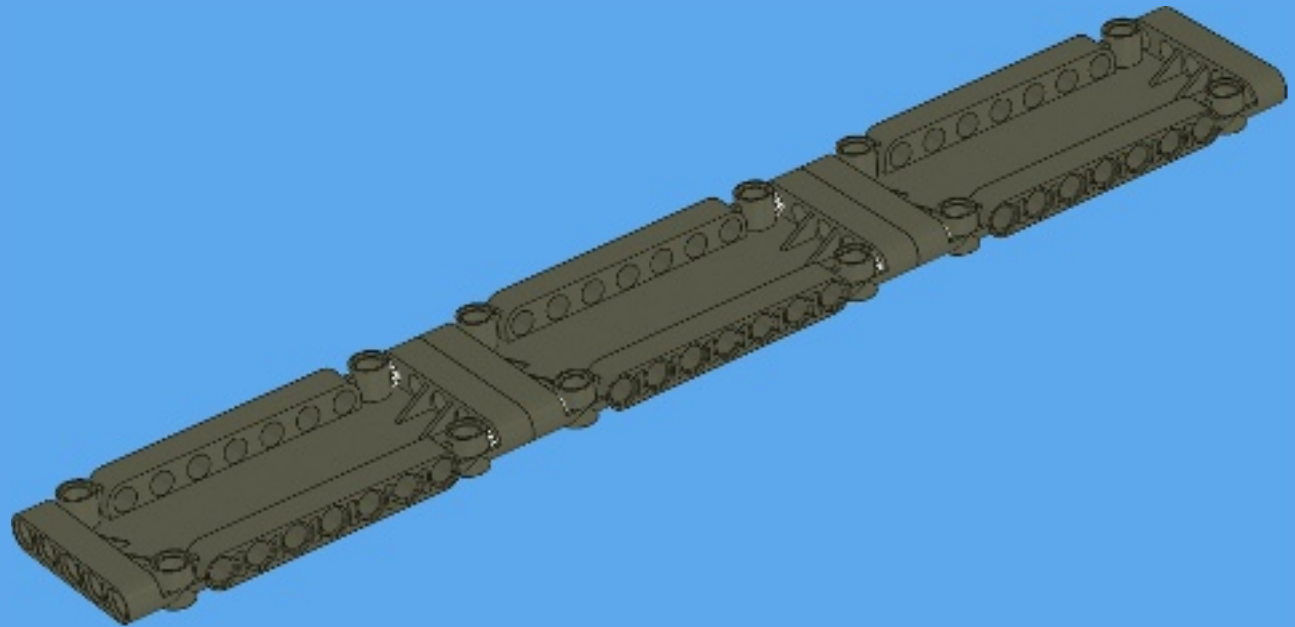



7x

3

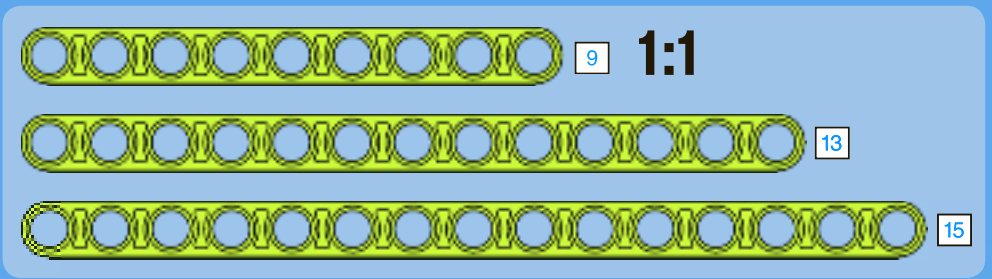
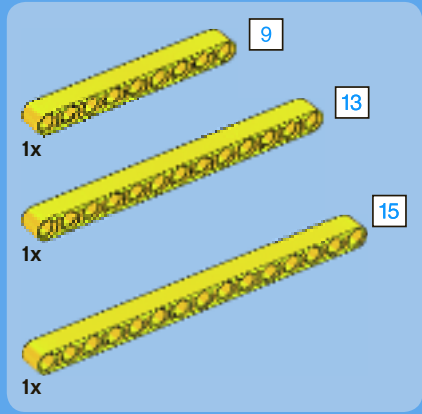
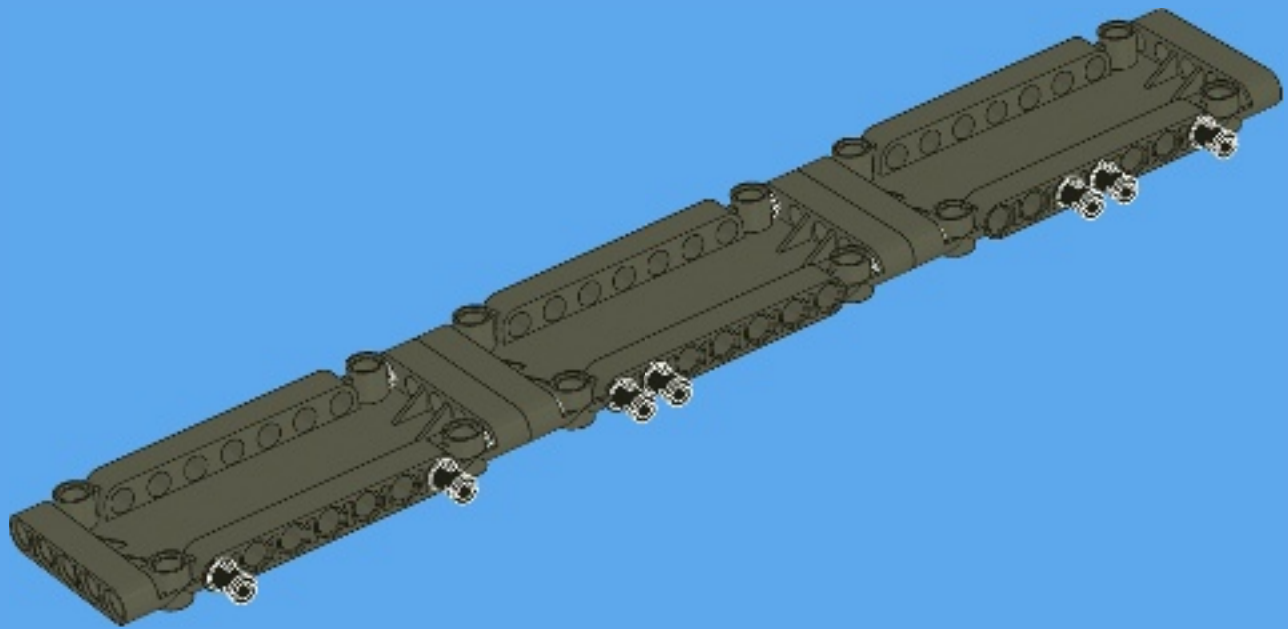

4

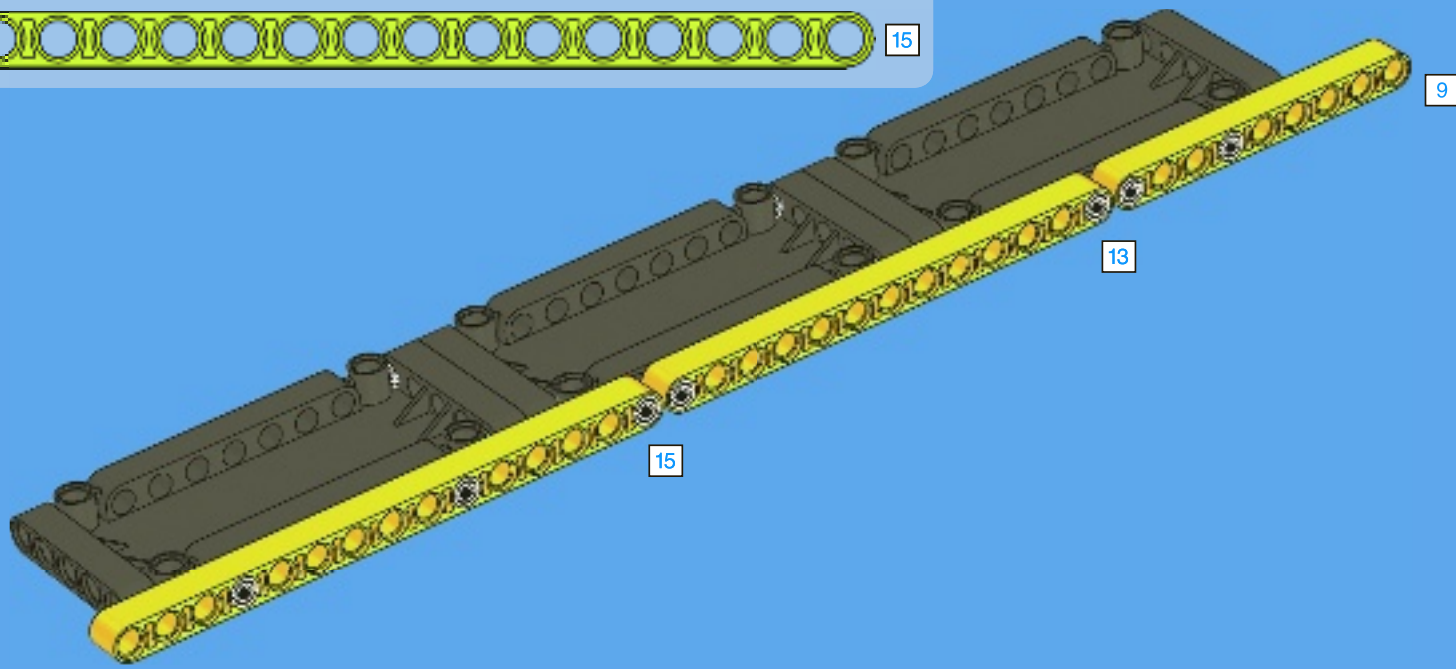

5

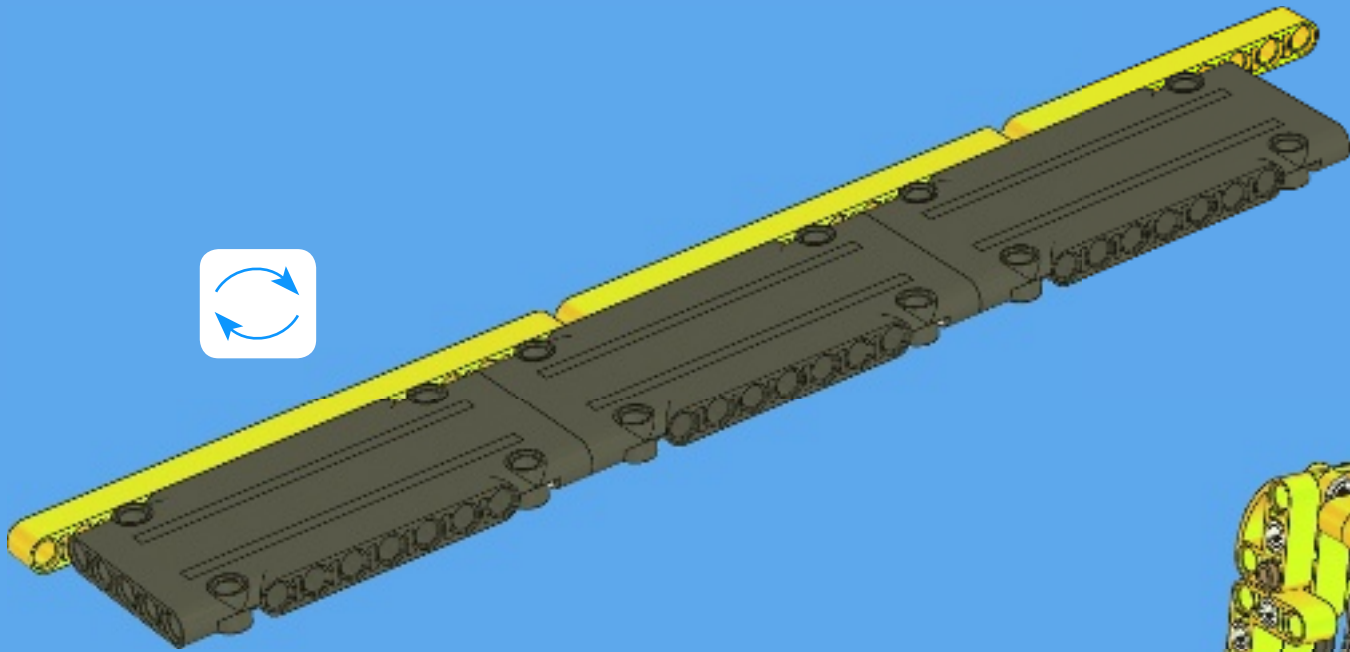

87

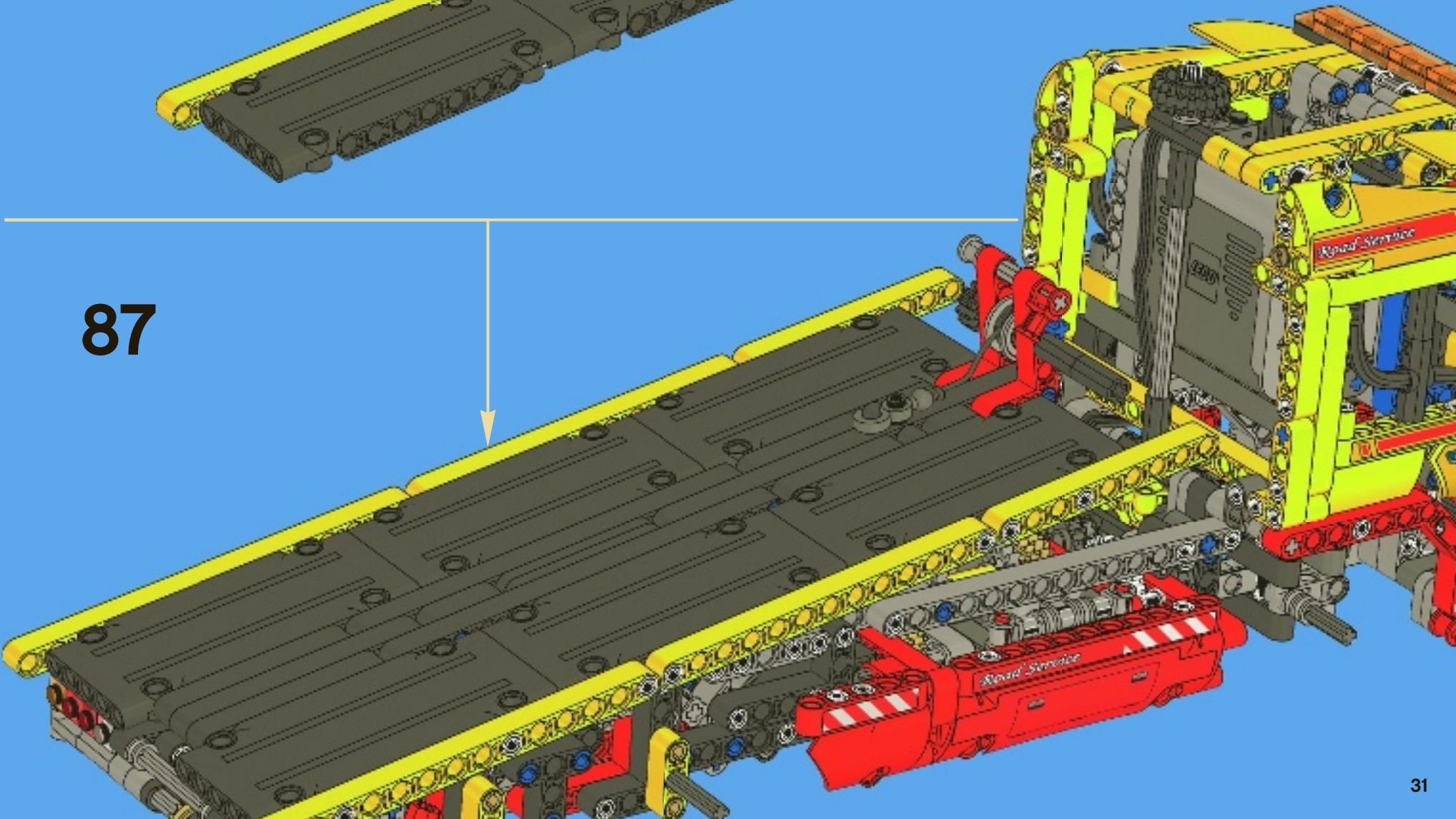

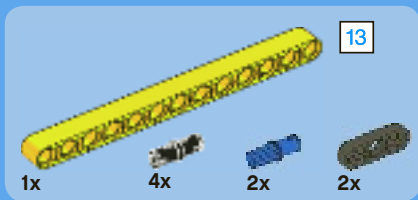

88

1

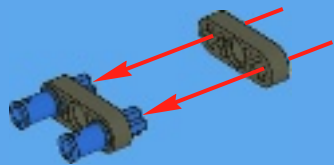

2

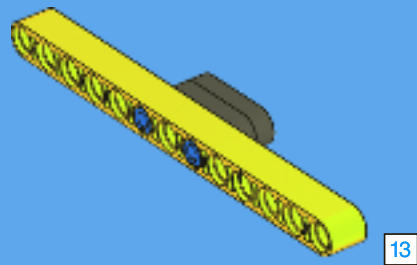

3

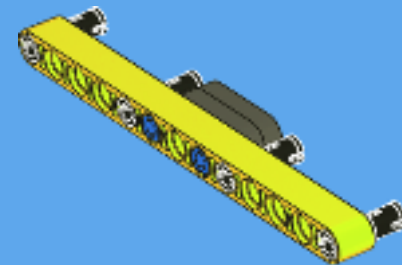

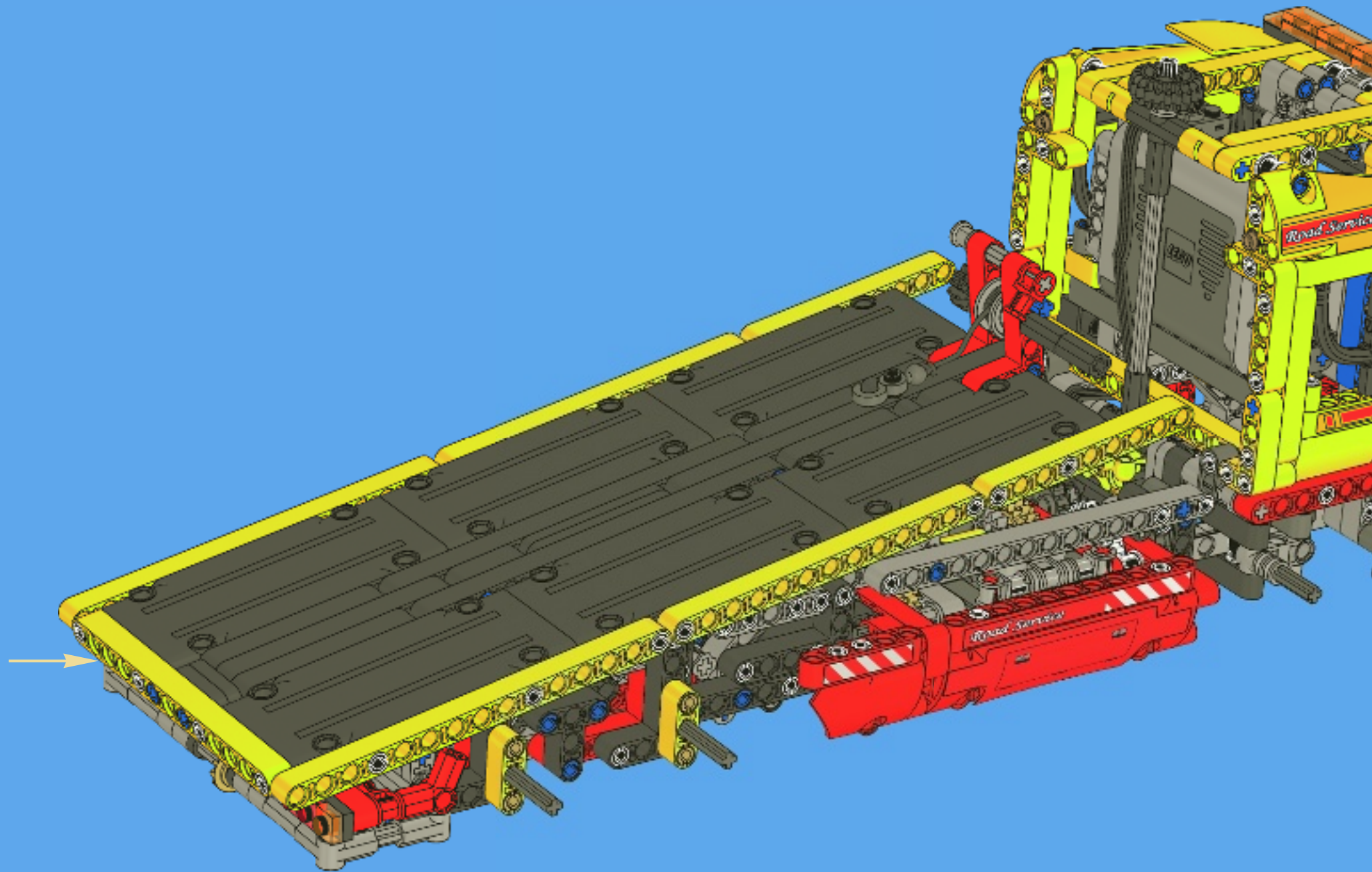

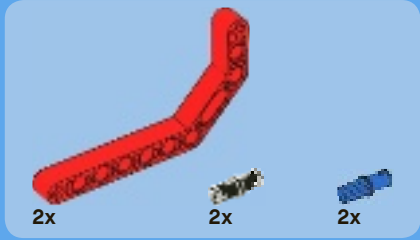
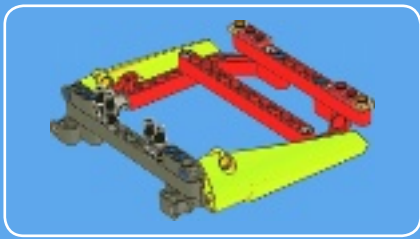

1

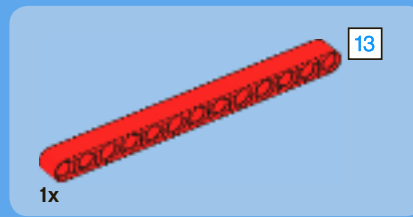
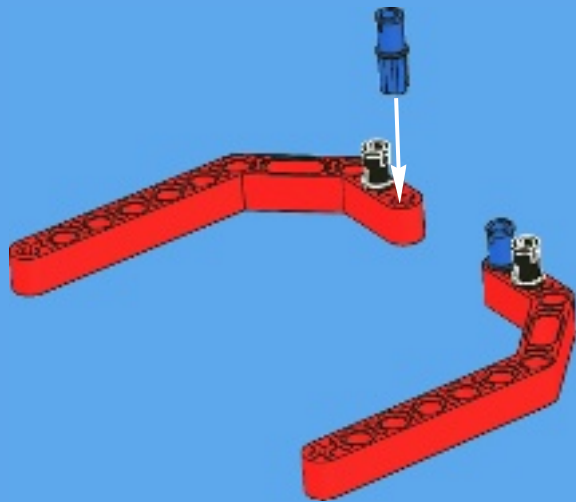

2

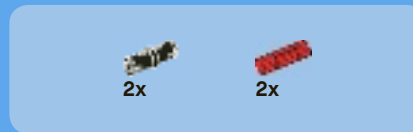
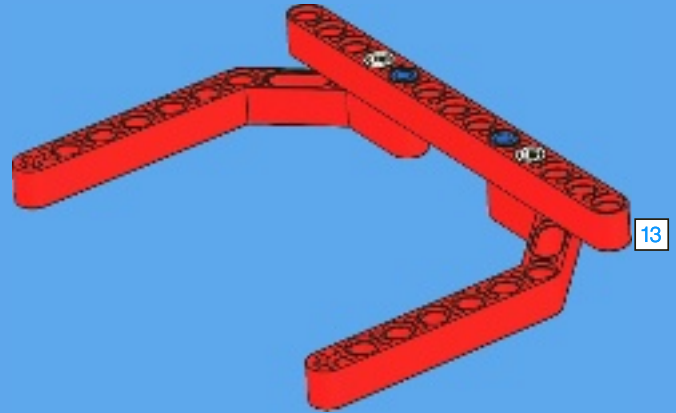

3

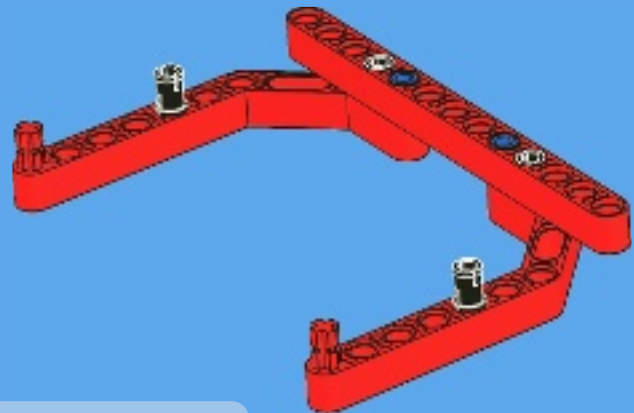

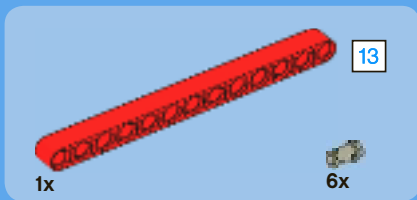

4

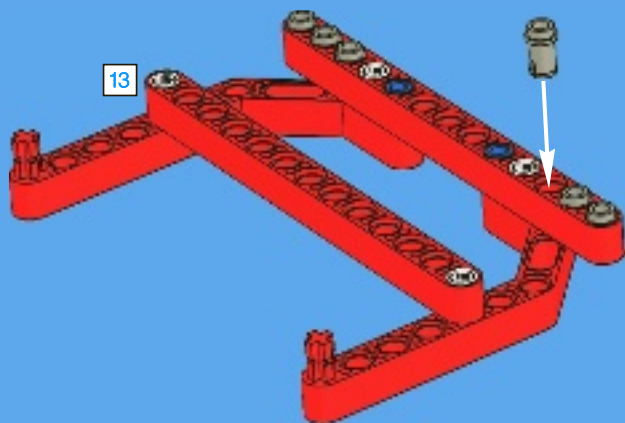

5

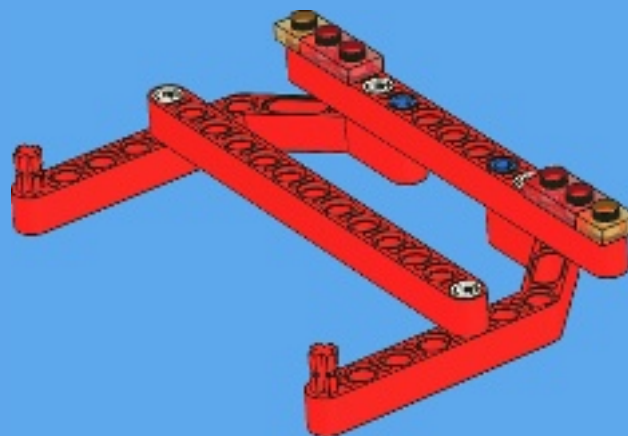

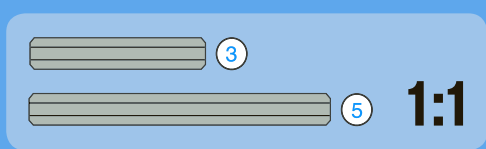
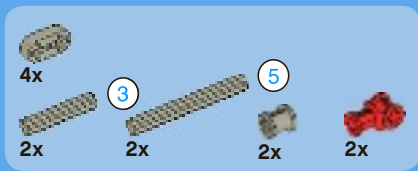

6

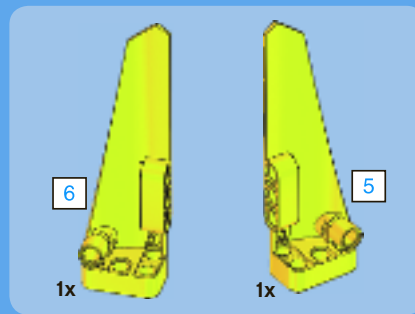
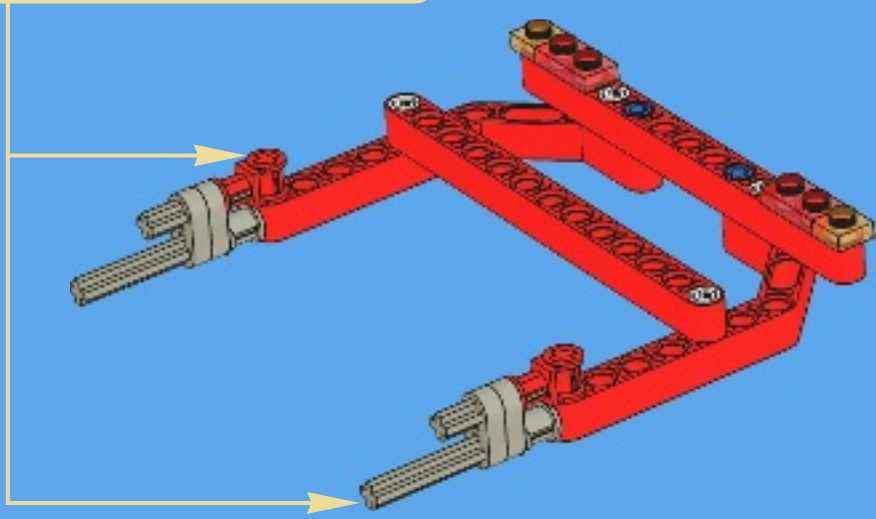
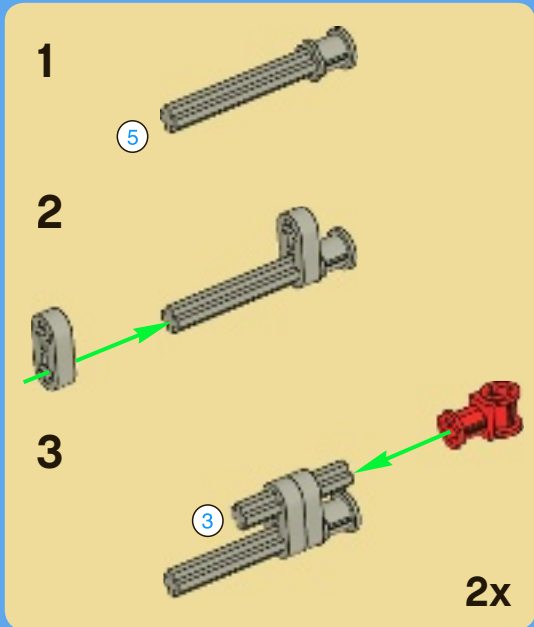

7

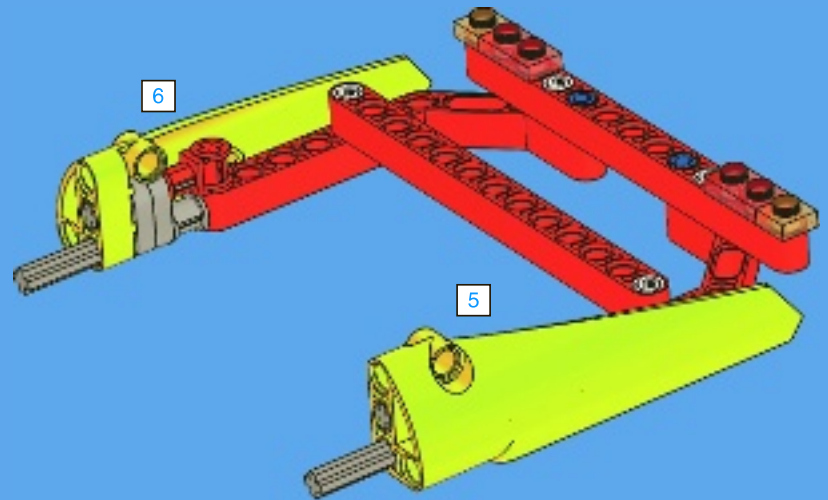

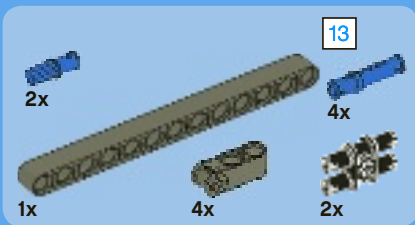

8

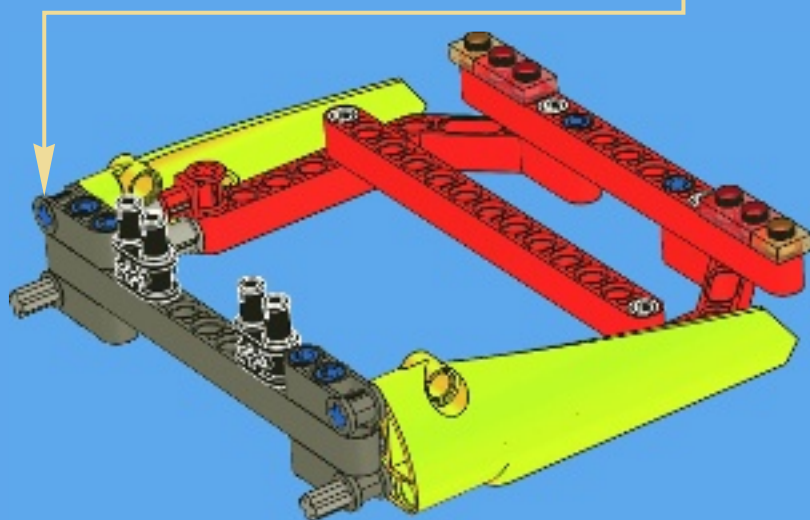
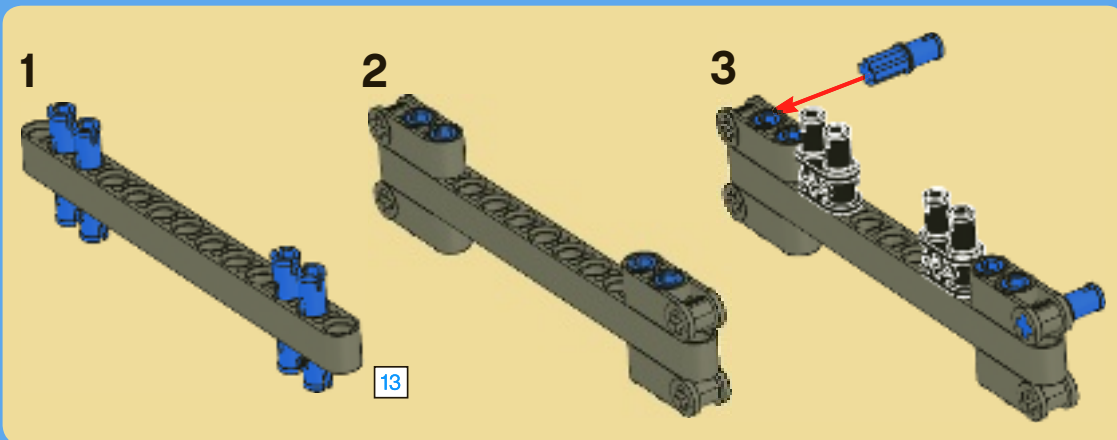

1:1

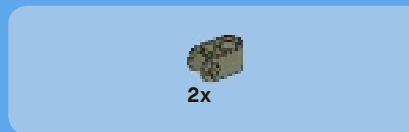

9

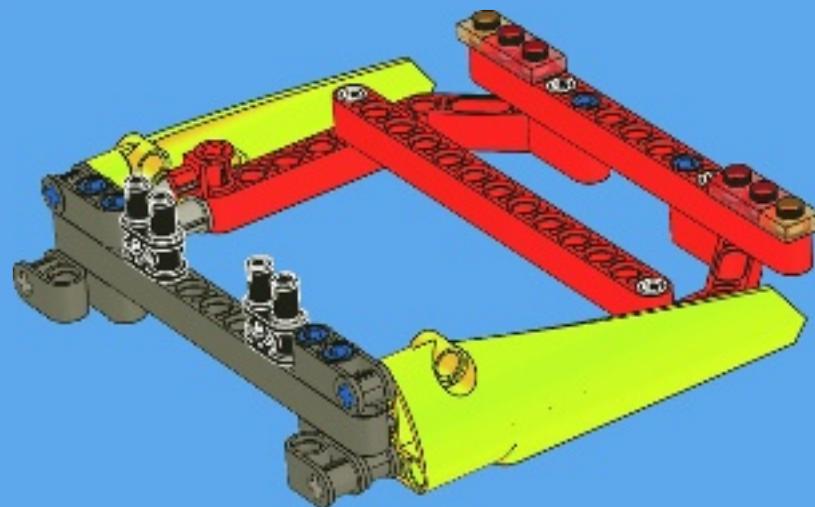

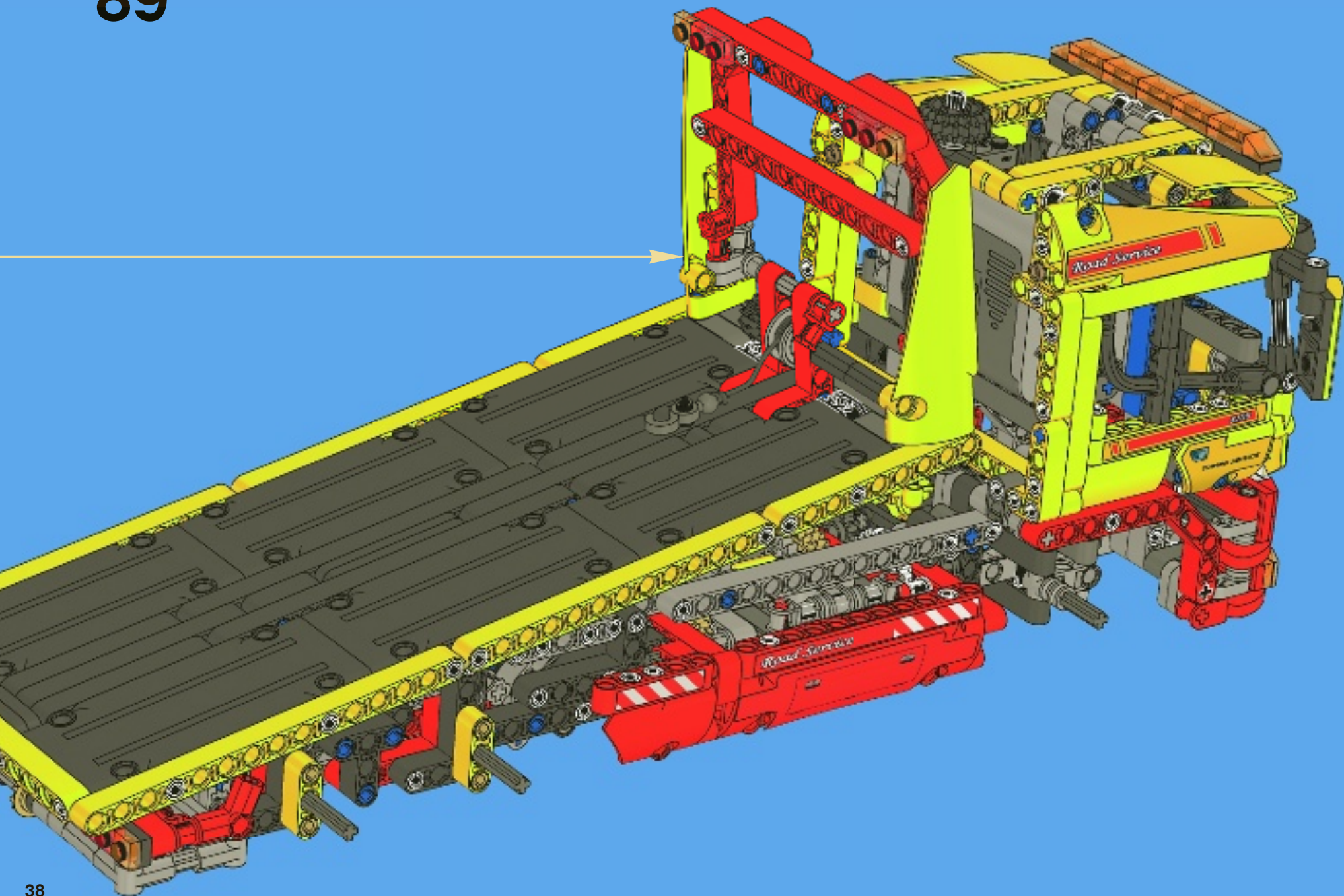



90

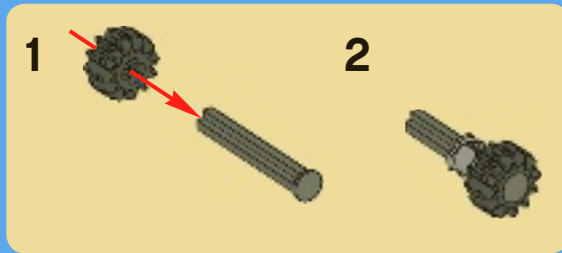

2

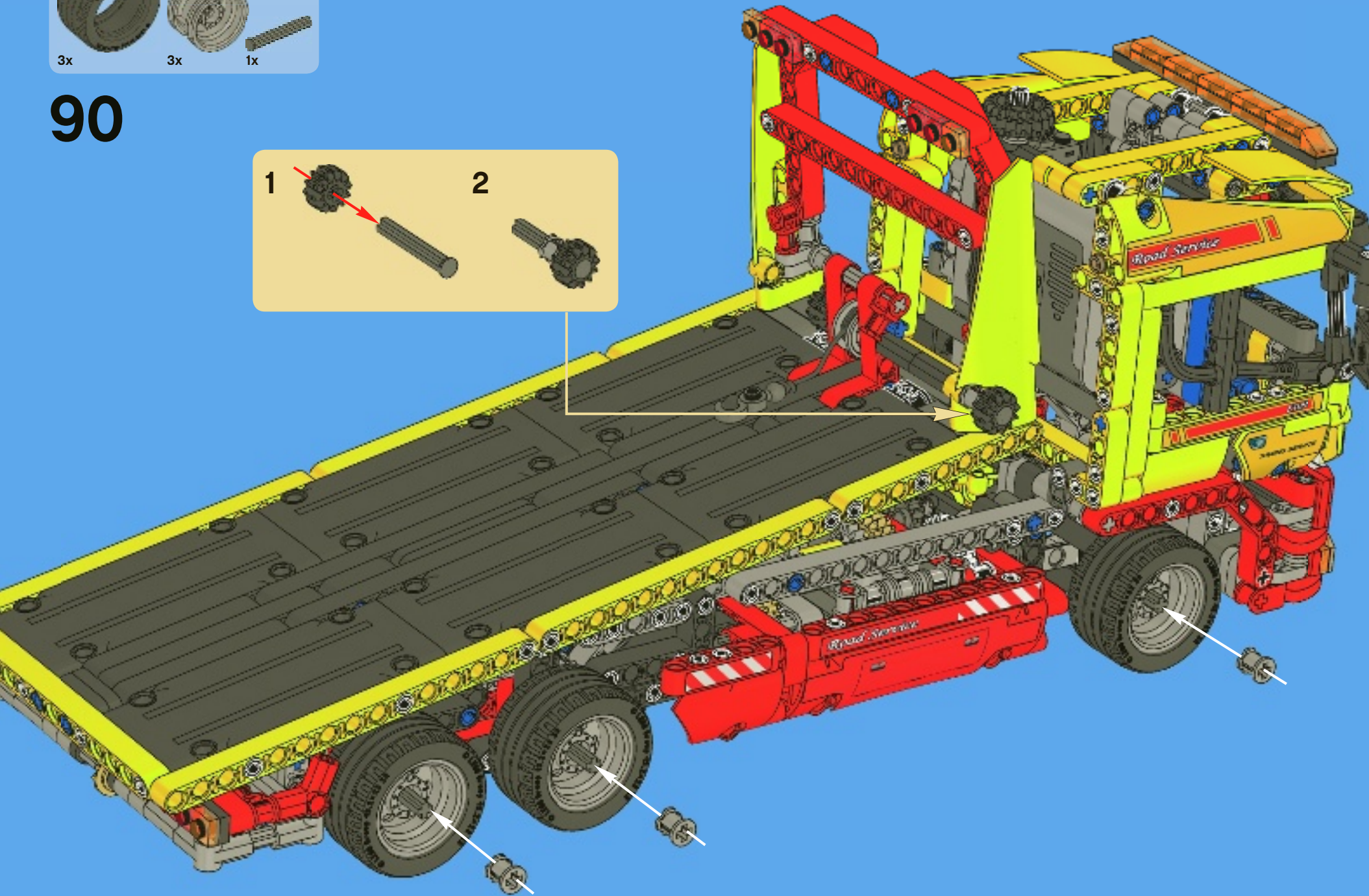



91

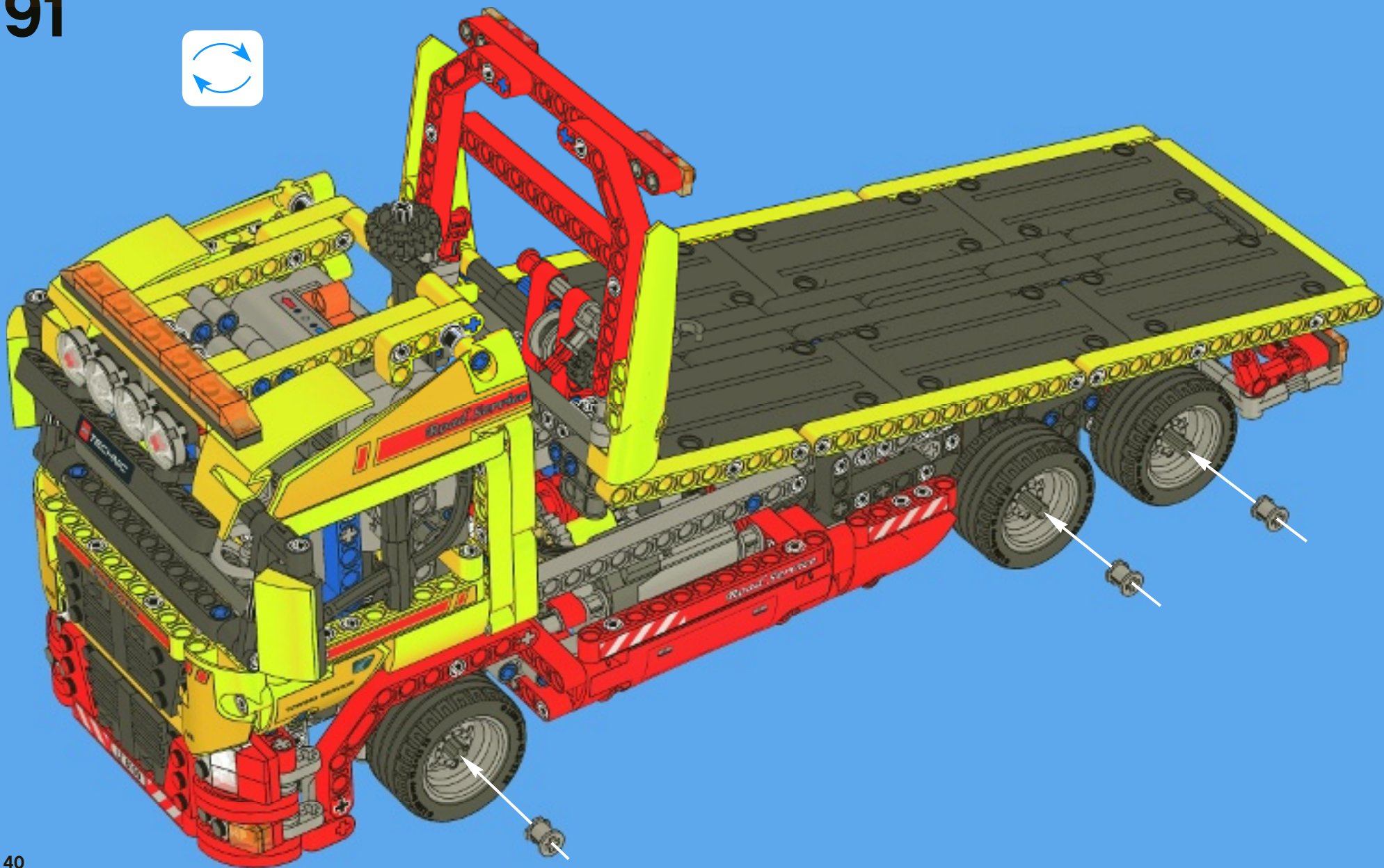

92

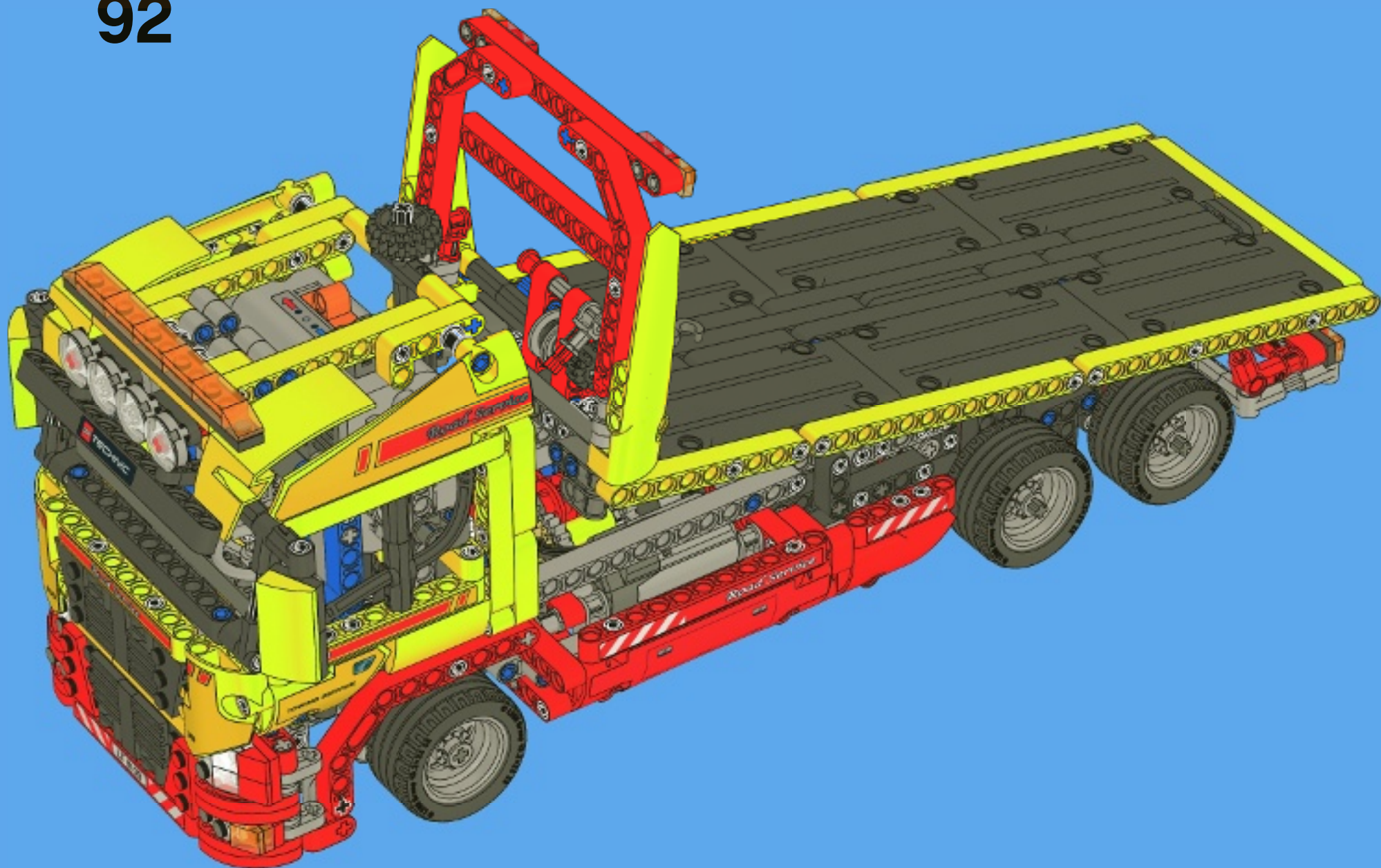

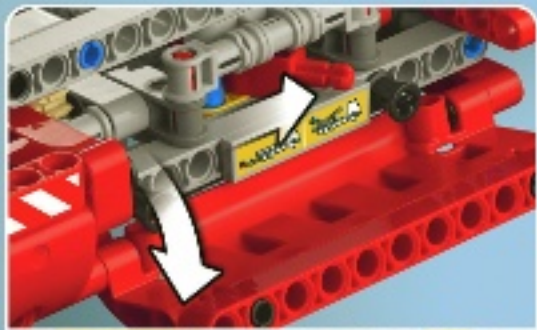

1

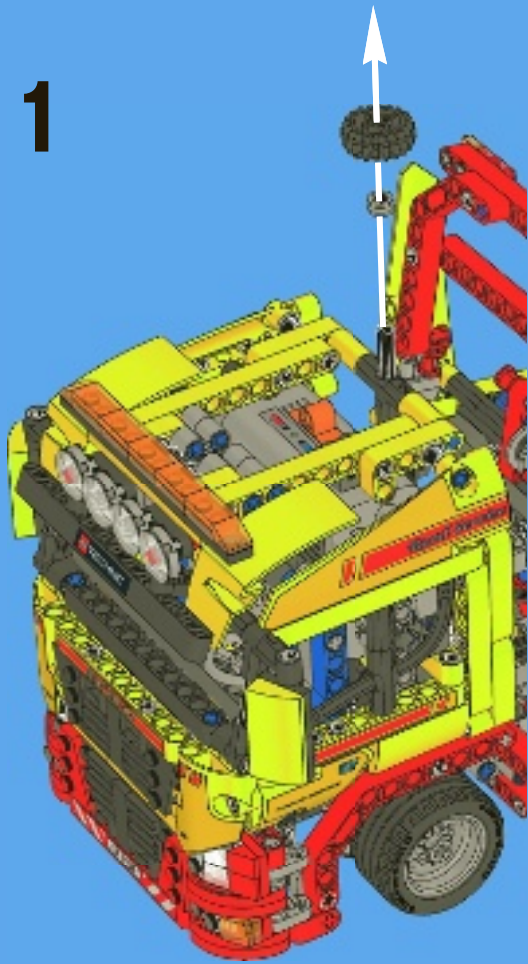

2

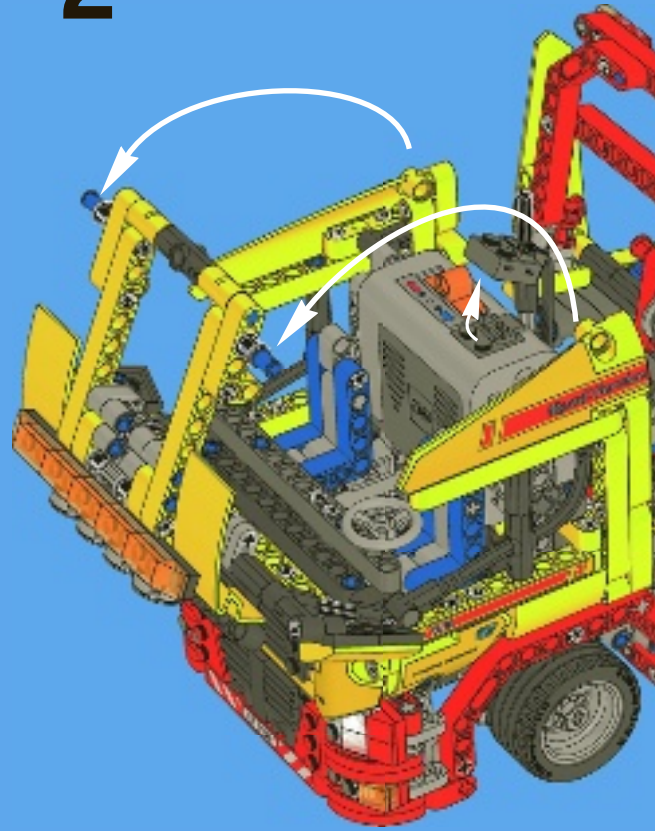

3

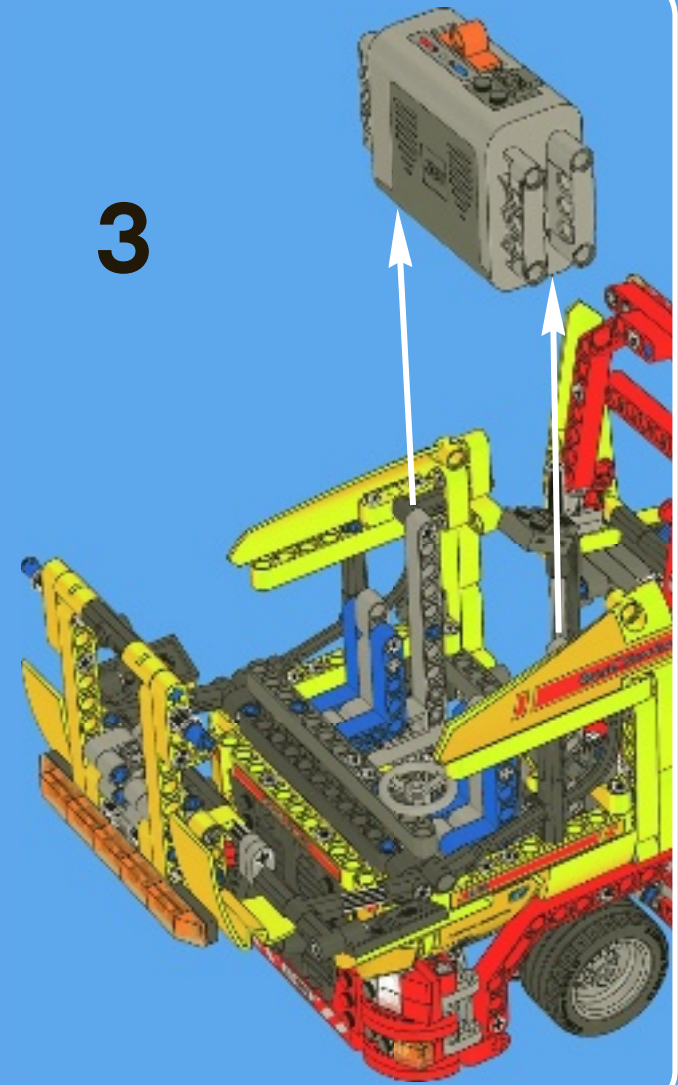

- 2x 362301
- 4x 302001
- 1x 4180504
- 1x 4544140
- 1x 4540381
- 4x 4186017
- 8x 4514554
- 1x 4207456
- 2x 4565452
- 1x 4514557
- 2x 4514555
- 4x 4504379
- 3x 302421
- 2x 242021
- 3x 302121
- 3x 371021
- 1x 379521
- 1x 303521
- 1x 4180504
- 1x 4180533
- 1x 4558873
- 1x 4558872
- 2x 4525727
- 1x 4278957
- 4x 4141270
- 6x 4143154
- 2x 4141743
- 4x 4268653
- 2x 4188298
- 8x 4566064
- 37x 4142865
- 4x 4227544
- 5x 4118897
- 1x 4270473
- 2x 4153718
- 2x 4153718
- 4x 4142132
- 4x 4645733
- 4x 4562805
- 3x 4522938
- 2x 4542575
- 4x 4158923
- 56x 4206482
- 75x 4514553
- 3x 4558172
- 2x 302124
- 2x 346024
- 4x 4597902
- 21x 4153707
- 6x 4141628
- 2x 4144022
- 7x 4495934
- 9x 4187136
- 3x 4522935
- 3x 4542579
- 1x 4297719
- 2x 4558800
- 2x 4558817
- 2x 4558876
- 2x 4558879
- 1x 4518865
- 1x 4518866
- 3x 4526983
- 2x 4203493
- 2x 300126
- 4x 3200026
- 6x 302226
- 2x 362326
- 2x 4558170
- 2x 302126
- 2x 371026
- 1x 4514845
- 2x 4234438
- 8x 241226
- 2x 244426
- 1x 4180508
- 1x 4180536
- 18x 4515185
- 5x 4552347
- 16x 4142823
- 4x 4495935
- 5x 4645732
- 1x 4156150
- 1x 4522933
- 3x 4542573
- 1x 4562009
- 2x 4540906
- 10x 370526
- 4x 370626

5x
4162857

2x
4558692

11x
4107828

2x
4114634

2x
4114670

9x
4177431

1x
4177430

9x
4107783

18x
4107085

182x
4121715

18x
4512363

3x
4563044

5x
4119589

25x
4140801

2x
4184169

6x
4184286

6x
4566243

4x
4244362

2x
3000840

4x
4167842

4x
3005740

4x
4278412

4x
4201019

3x
4566927

4x
4244369

4x
4542673

7x
4280341

5x
4541710

6x
4297210

1x
4521532

4x
4233493

1x
4211356

1x
4211376

4x
4211475

7x
4211862

12x
4211610

5x
4211651

4x
4611705

11x
4542577

4x
4234240

1x
4540797

4x
4211629

1x
4538007

3x
4211621

18x
4211741

10x
4211574

1x
4580510

23x
4211573

3x
4560175

20x
4211483

24x
4211622

5x
4211553

4x
4509886

4x
4512360

2x
4225033

28x
4211815

17x
4211639

7x
4211805

5x
4535768

2x
4640536

2x
4211510

1x
4506083

1x
4506078

1x
4212529

3x
4522937

7x
4210851

16x
4210857

4x
4211050

7x
4560177

7x
4508553

4x
4499858

2x
4514559

2x
4237267

4x
4514558

5

11

15

13

3

5

7

9

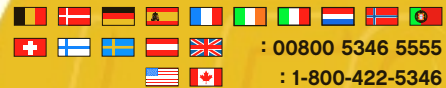

Customer Service
Kundenservice
Service Consommateurs
Servicio Al Consumidor

www.lego.com/service or dial

: 00800 5346 5555

: 1-800-422-5346



Technic.LEGO.com



+ power functions™



Alternative model building instructions only available for download from:
Bauanleitungen für alternative Modelle stehen ausschließlich als
Download zur Verfügung unter:
Les instructions de montage du modèle alternatif sont uniquement
disponibles sur Internet dans la rubrique « Montage » du site ;
Las instrucciones de construcción del modelo alternativo sólo pueden
obtenerse a través de:
Instruções de construção do modelo alternativo disponíveis para
descarregar apenas em:
Másfele modellepitési útmutatókat
csak az alábbi helyről tölthetsz le:
Technic.LEGO.com.

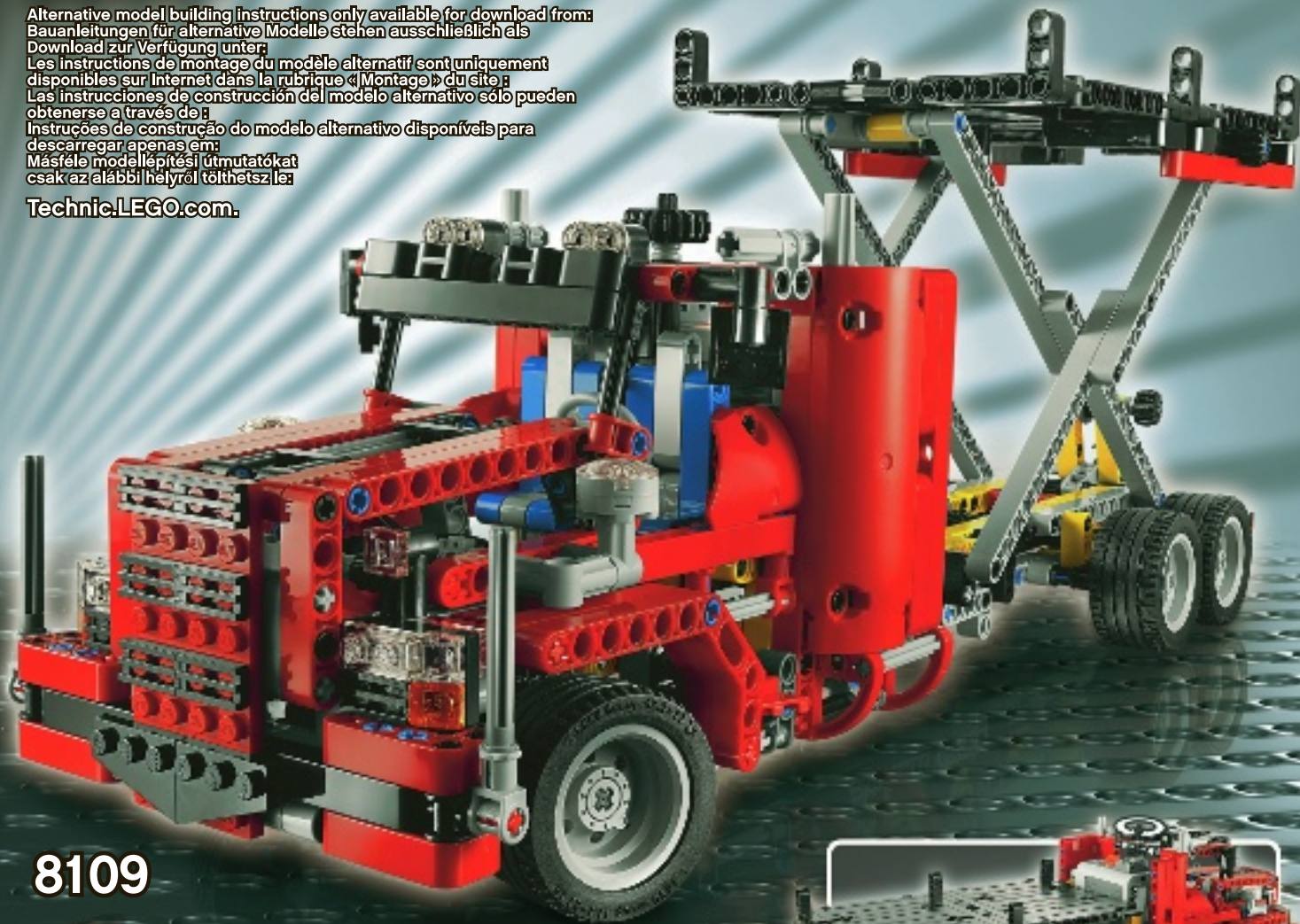

8109





WIN!

Go to www.LEGOsurvey.com/product to fill out a survey for a chance to win a cool LEGO® Product. No purchase necessary. Open to all residents where not prohibited.



www.LEGO.com



www.LEGOsurvey.com/product

GEWINNE!

Nimm an der Umfrage auf www.LEGOsurvey.com/product LEGO teil und hab die Chance ein cooles LEGO® Produkt zu gewinnen!

Die Teilnahme am Gewinnspiel führt zu keinerlei Kaufverpflichtungen. Teilnahme in allen nicht ausgeschlossenen Ländern möglich.

WIN!

Ga naar www.LEGOsurvey.com/product, vul een enquêteformulier in en maak kans op een cool LEGO® product.

Geen aankoopverplichting. Iedereen mag deelnemen, uitgezonderd ingezetenden van landen waar een enquêteverbod geldt.

GAGNE!

Visite www.LEGOsurvey.com/product pour répondre à un questionnaire et avoir une chance de gagner un produit LEGO® très cool!

Aucune obligation d'achat. Ouvert à tous les résidents des pays autorisés.

当てよう!

www.LEGOsurvey.com/product にアクセスして、アンケートにご記入ください。当選者にはレゴ®製品を差し上げます。

お買い上げの必要はありません。禁止されていない限り、すべての皆様にご利用いただけます。