

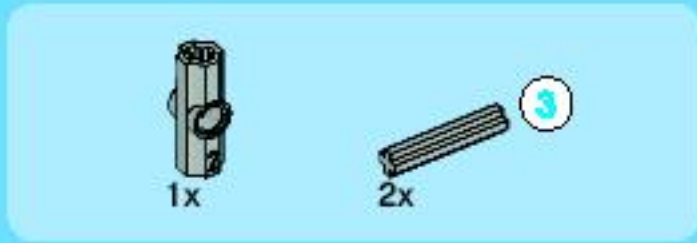

TECHNIC

8264

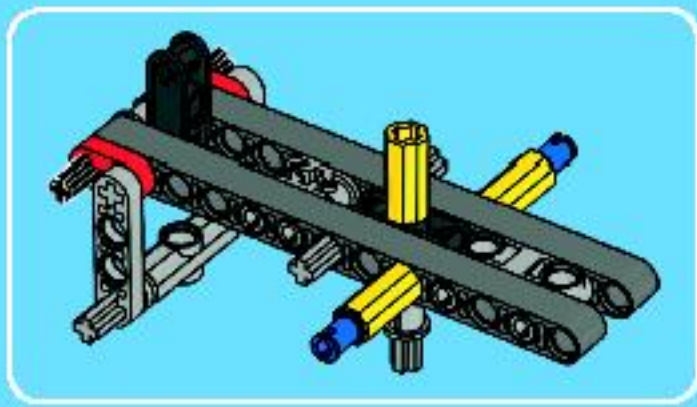



1

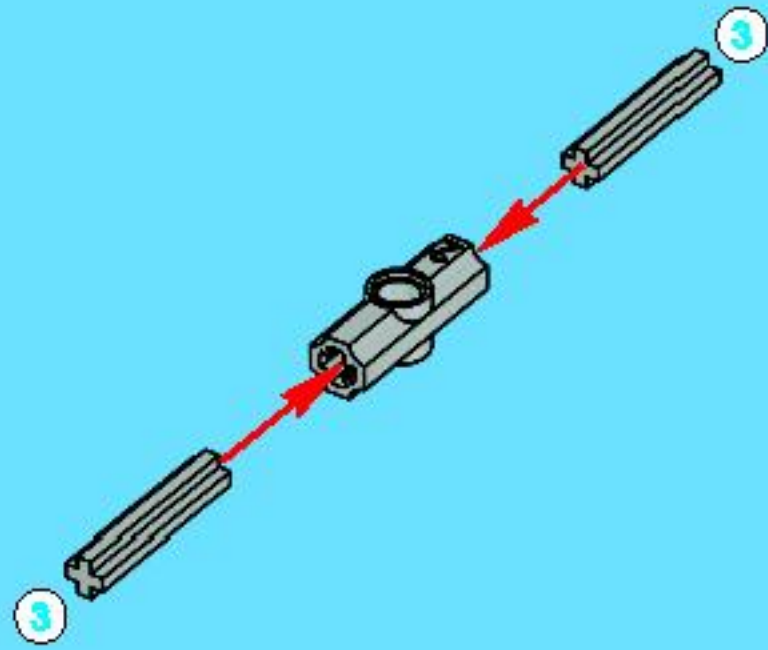

2

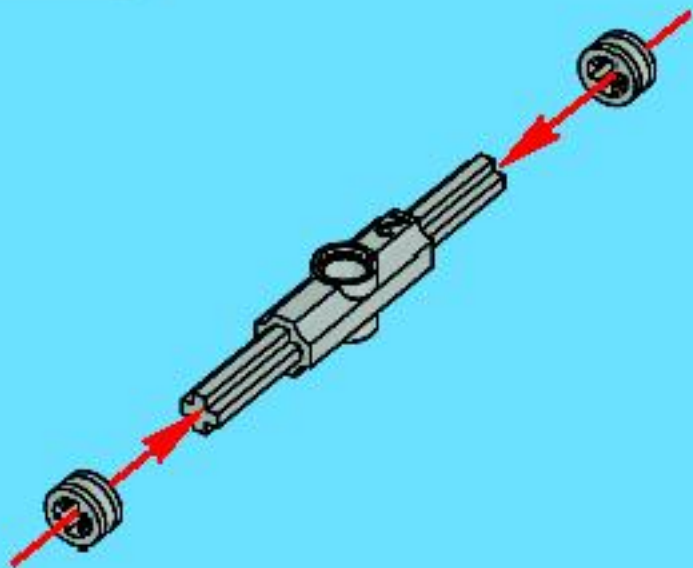

3

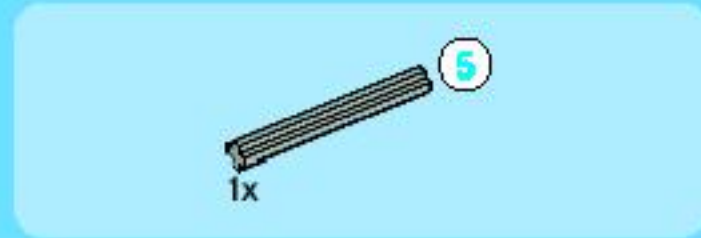
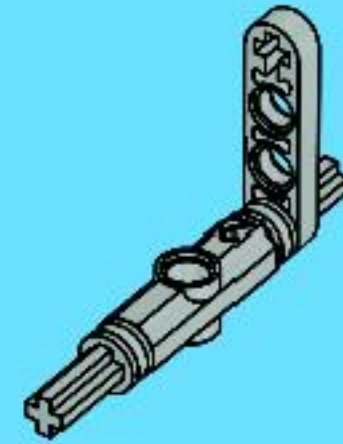

4

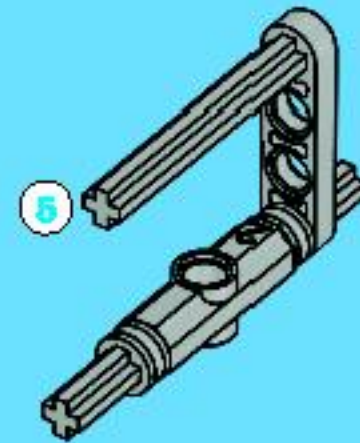

5

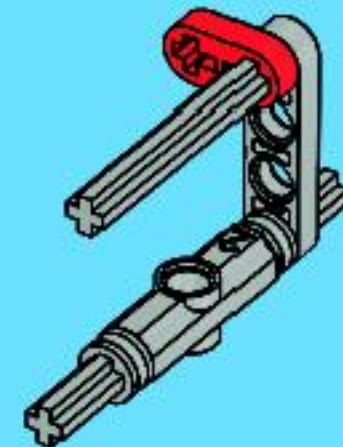



6

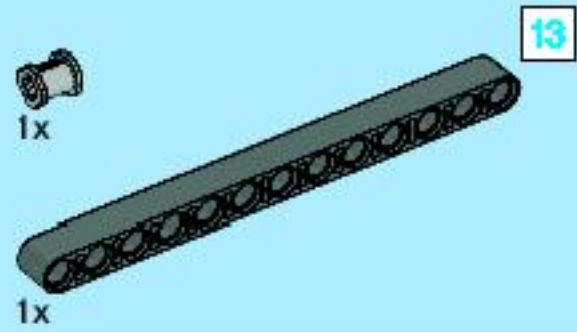
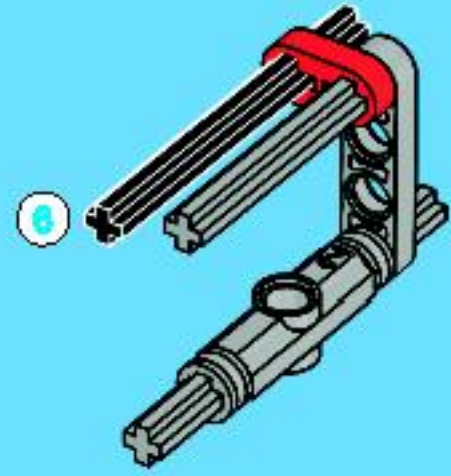

7

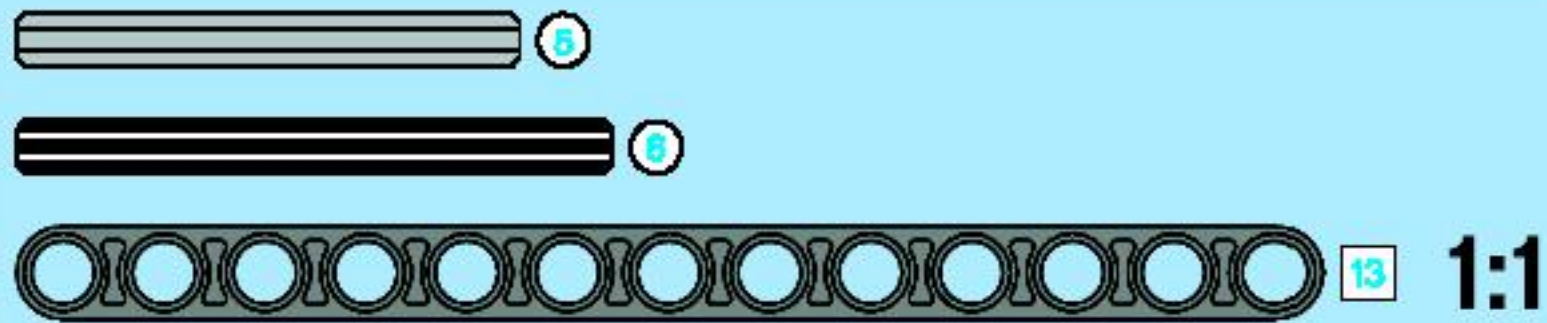
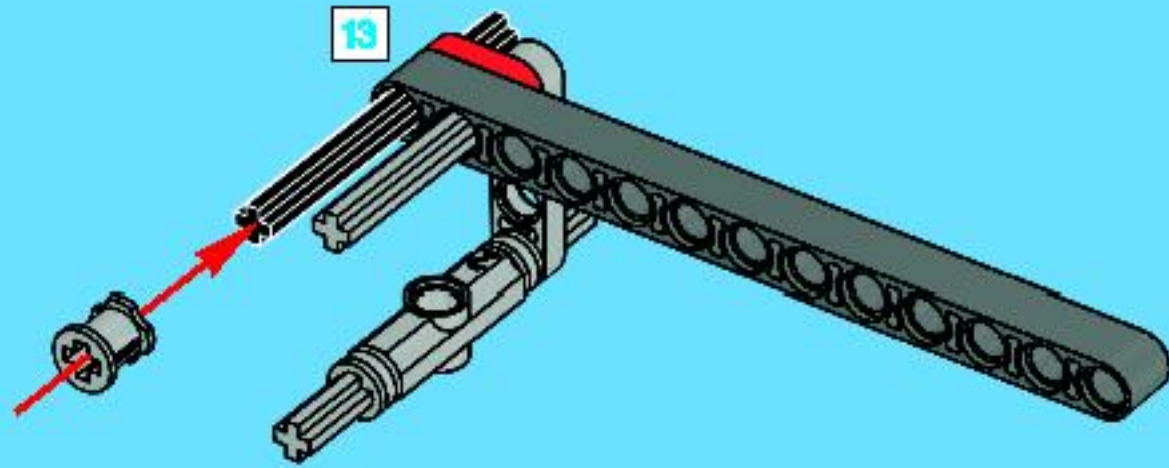

8

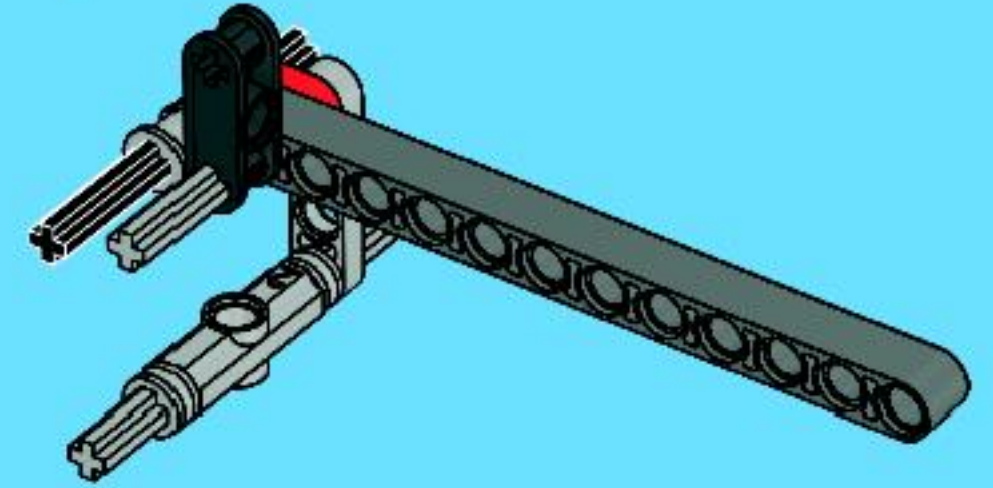

9

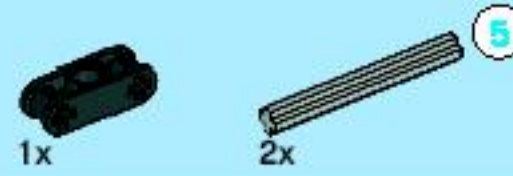
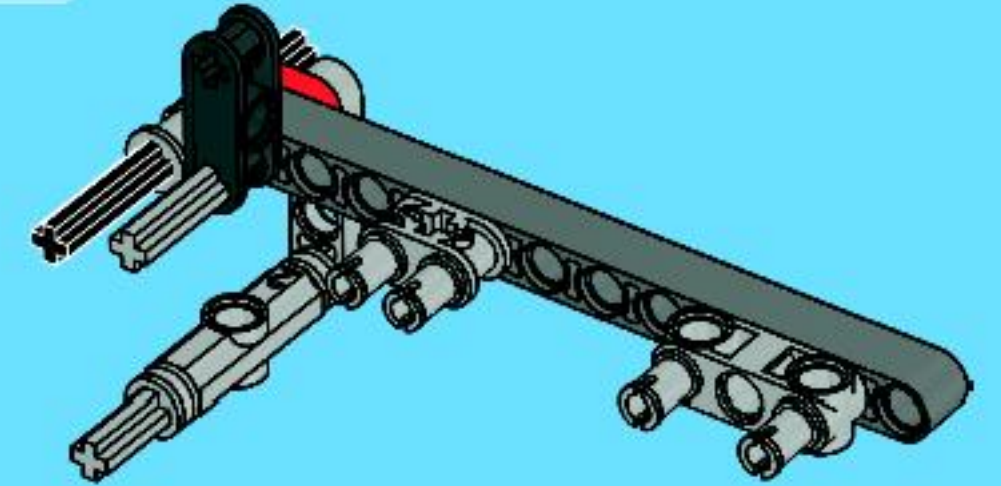

10

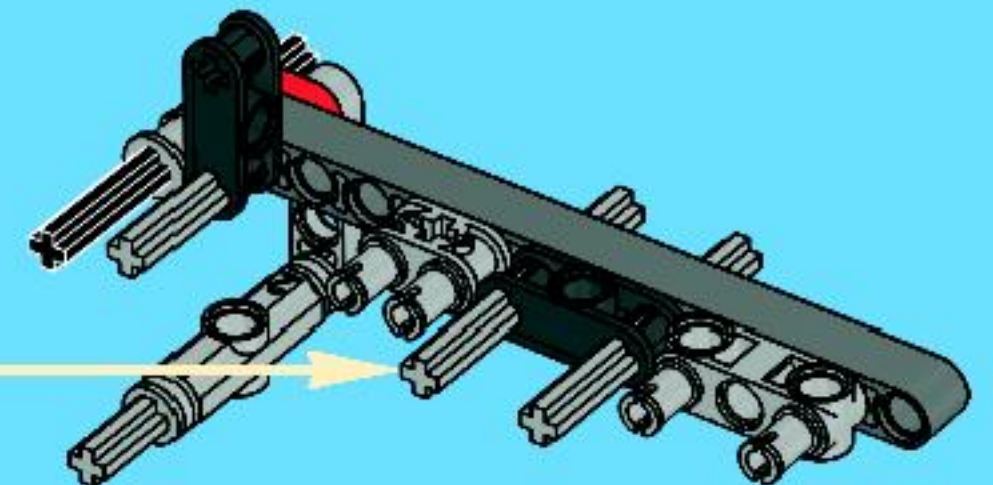
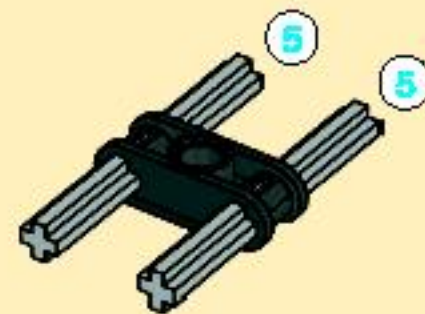

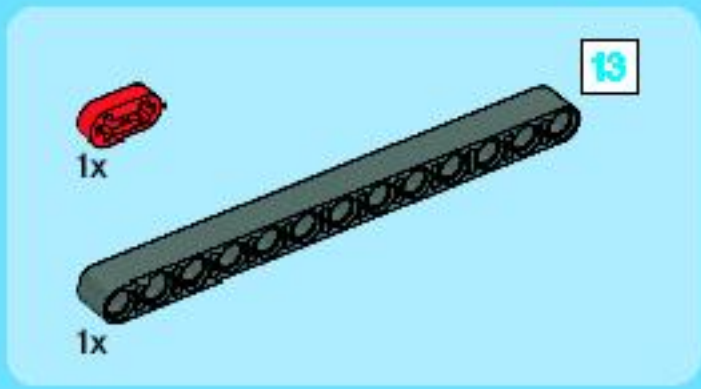

11

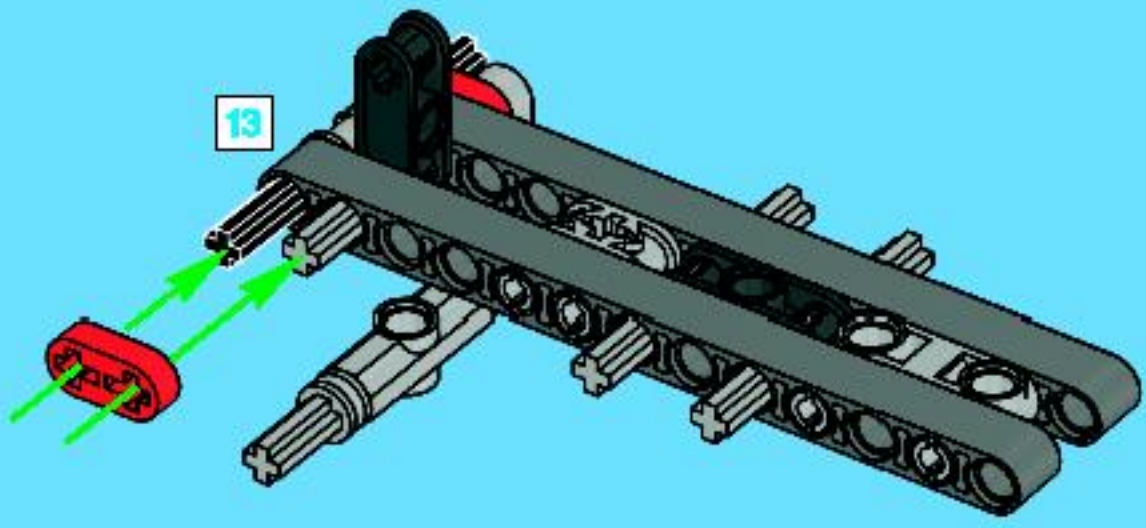

12

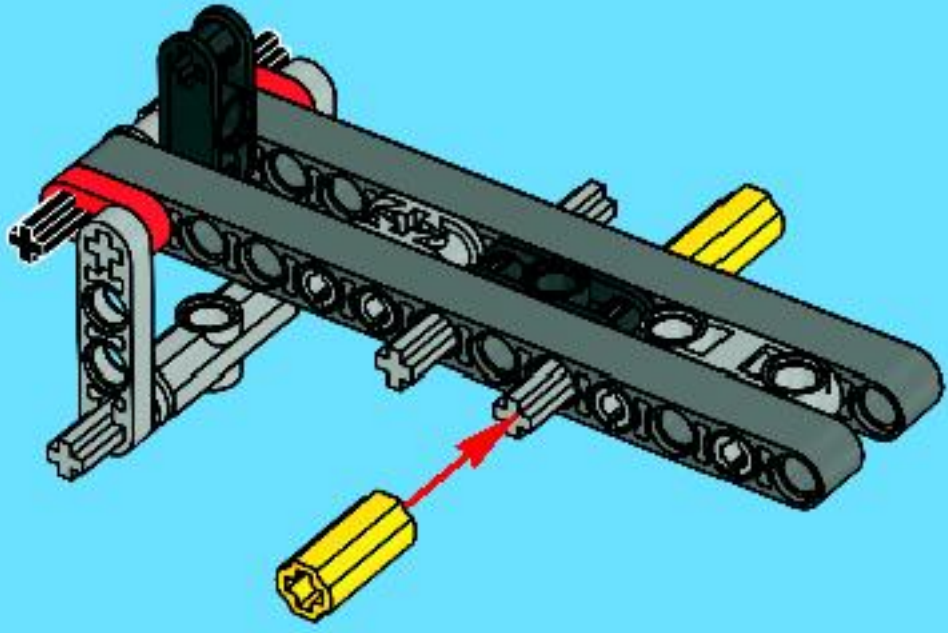

13

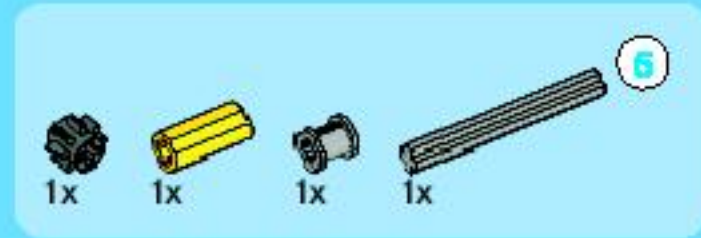
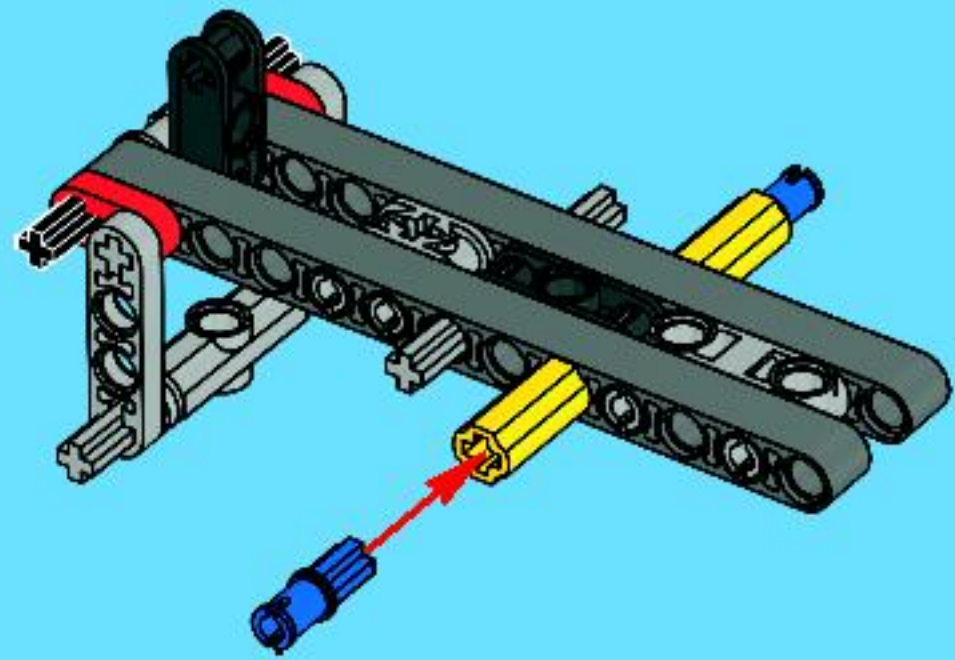

14

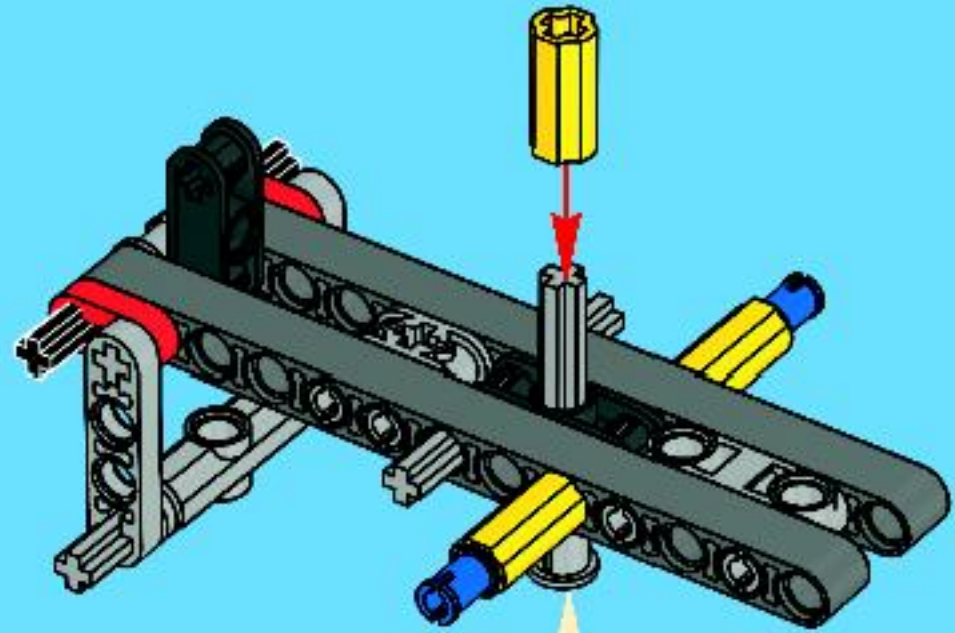
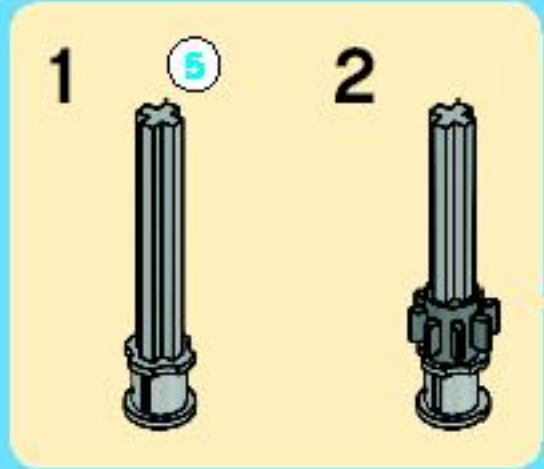

16

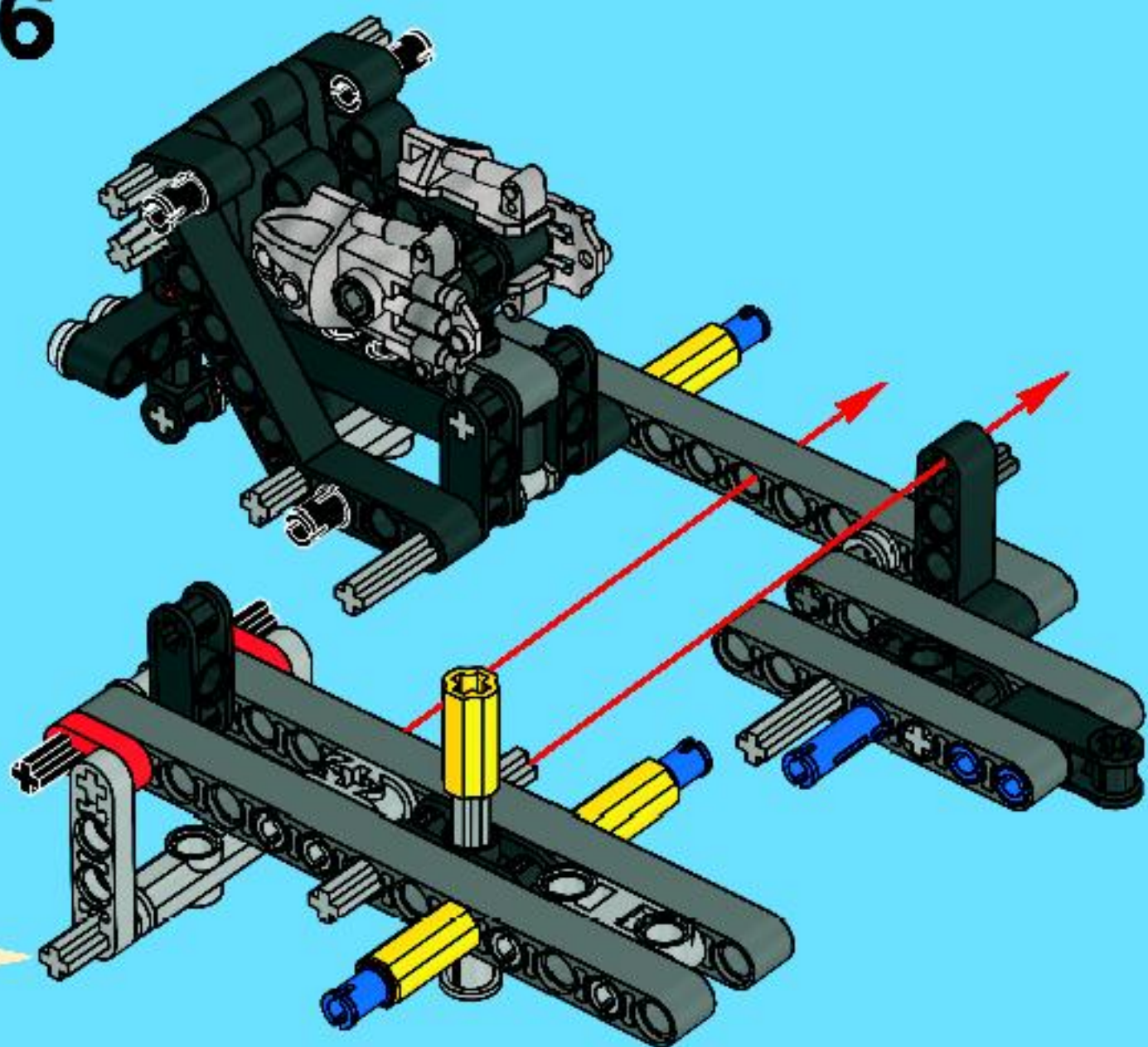

17

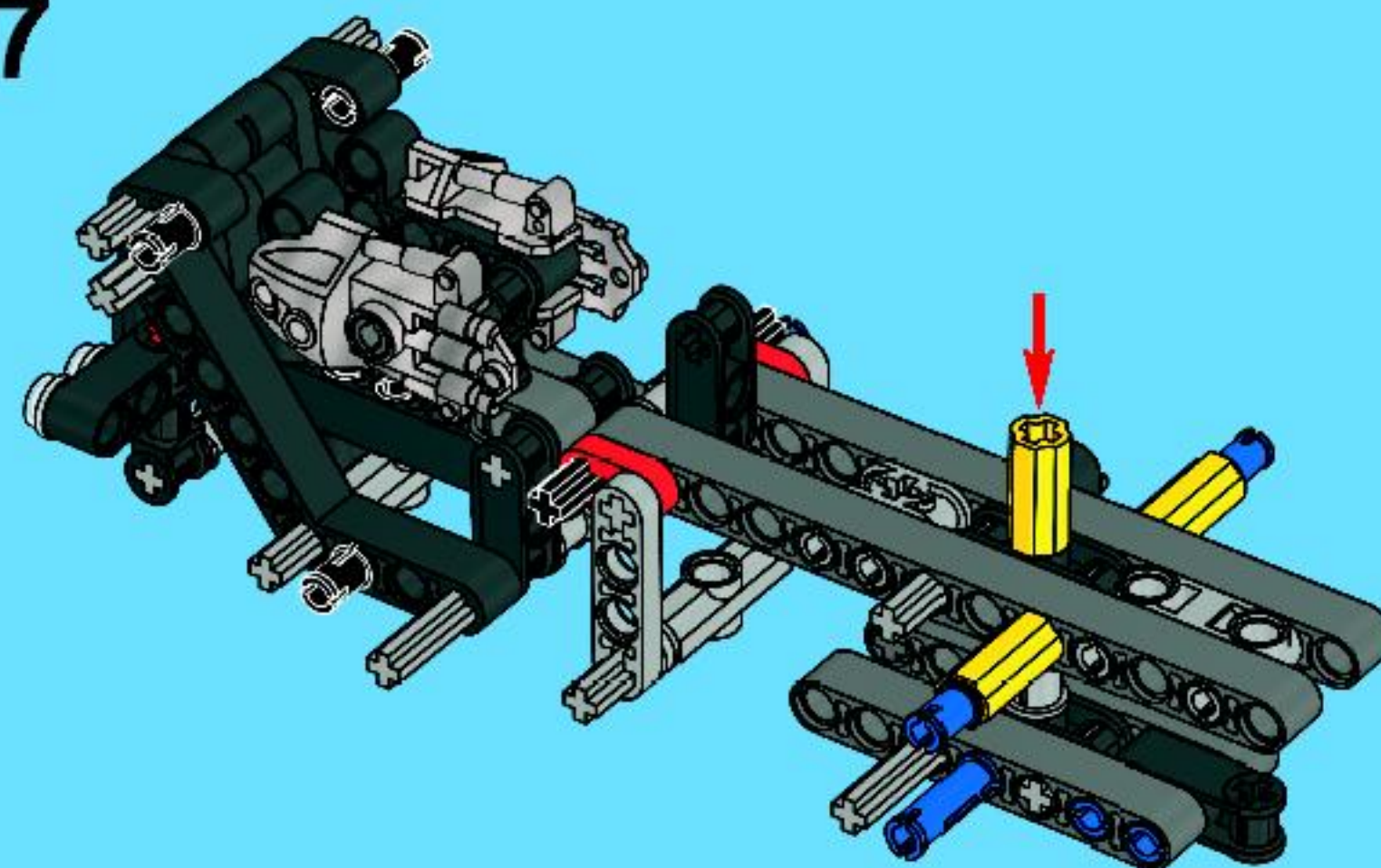

18

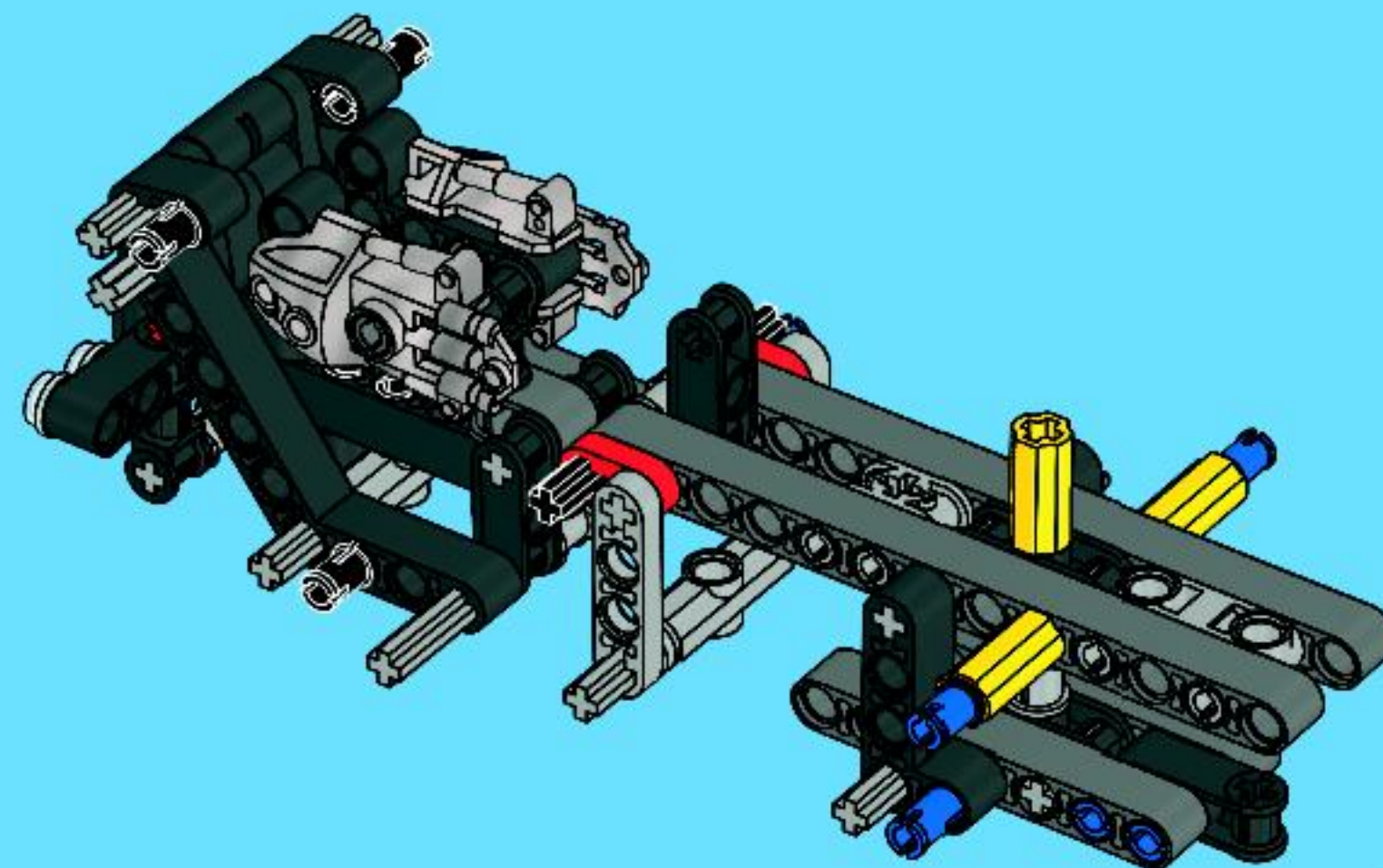

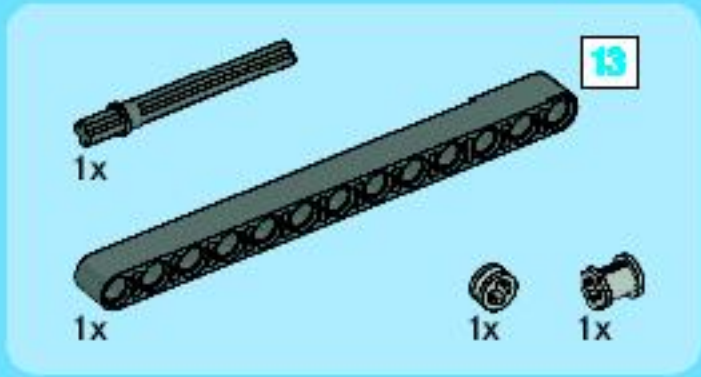

19

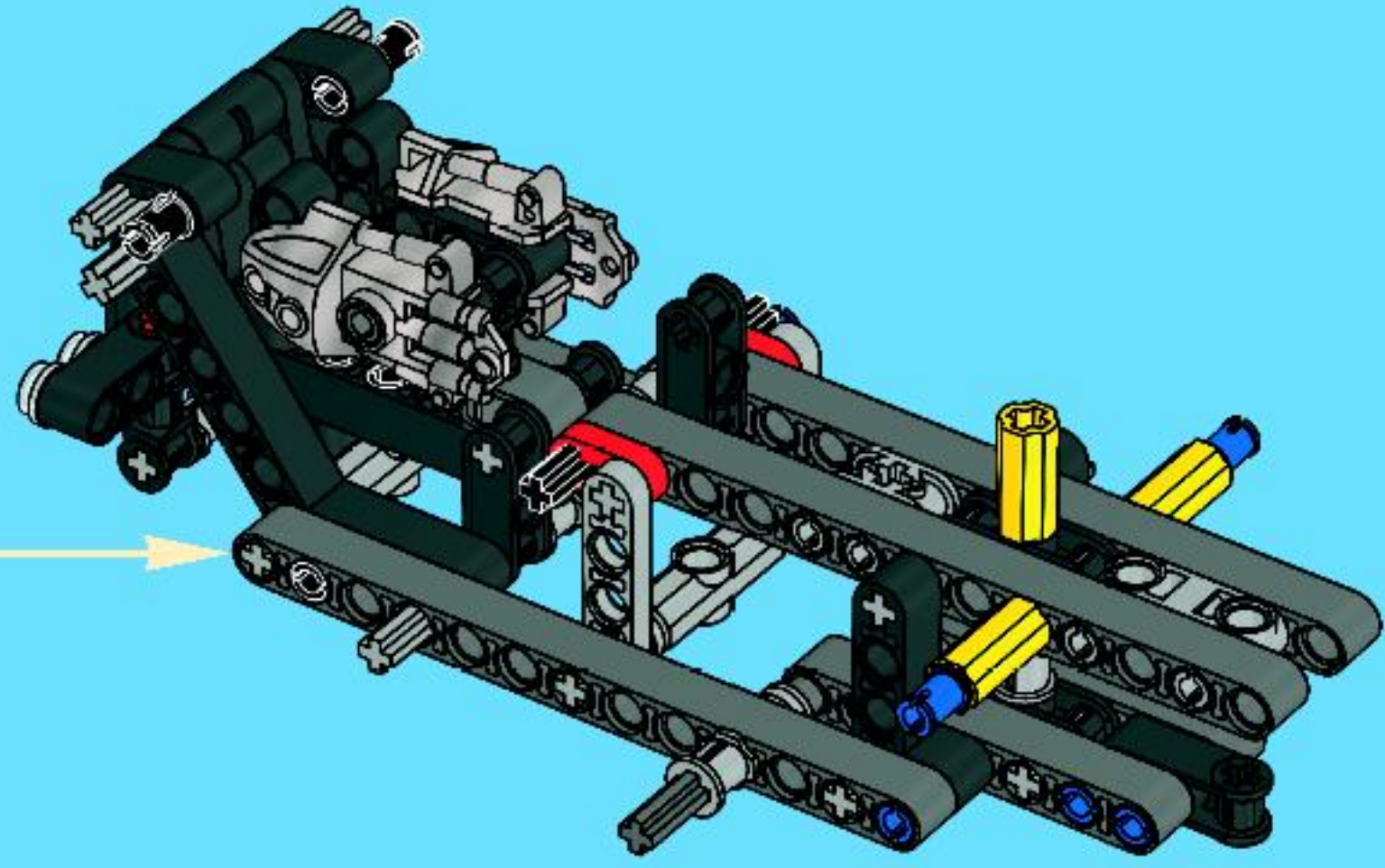
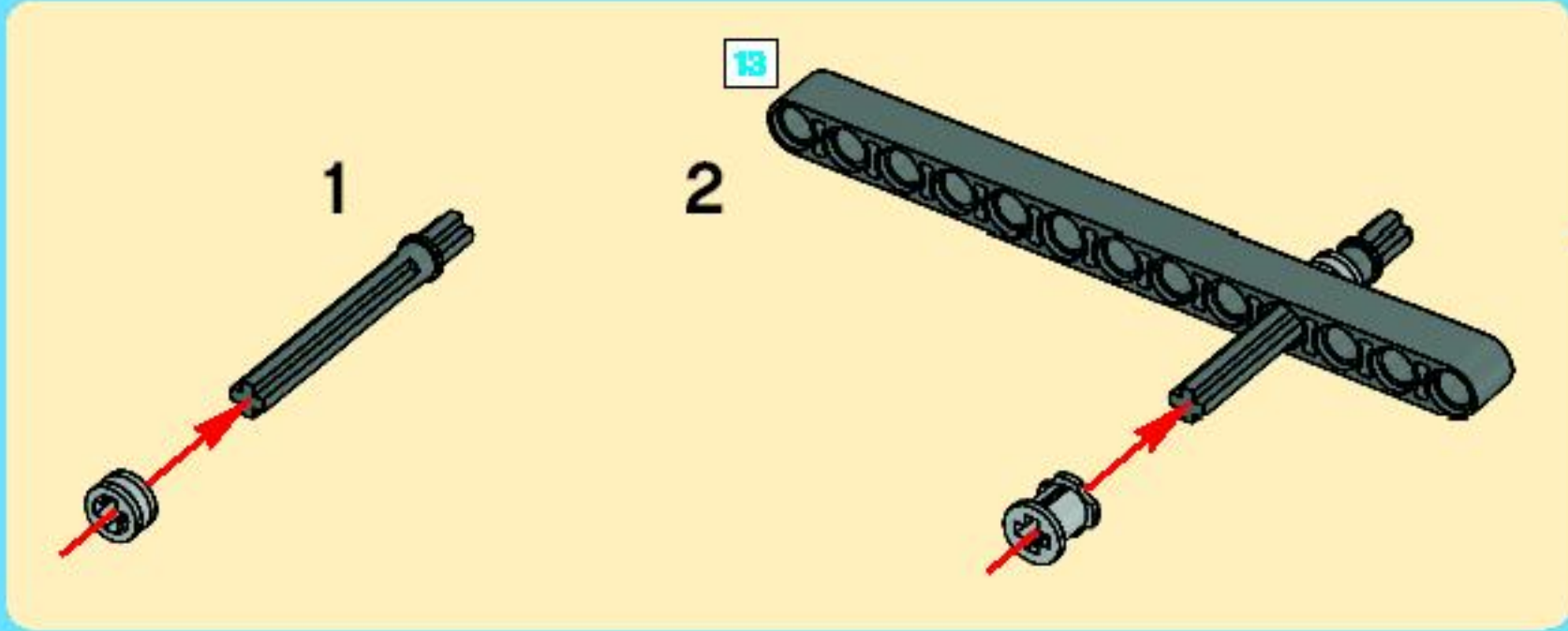

20

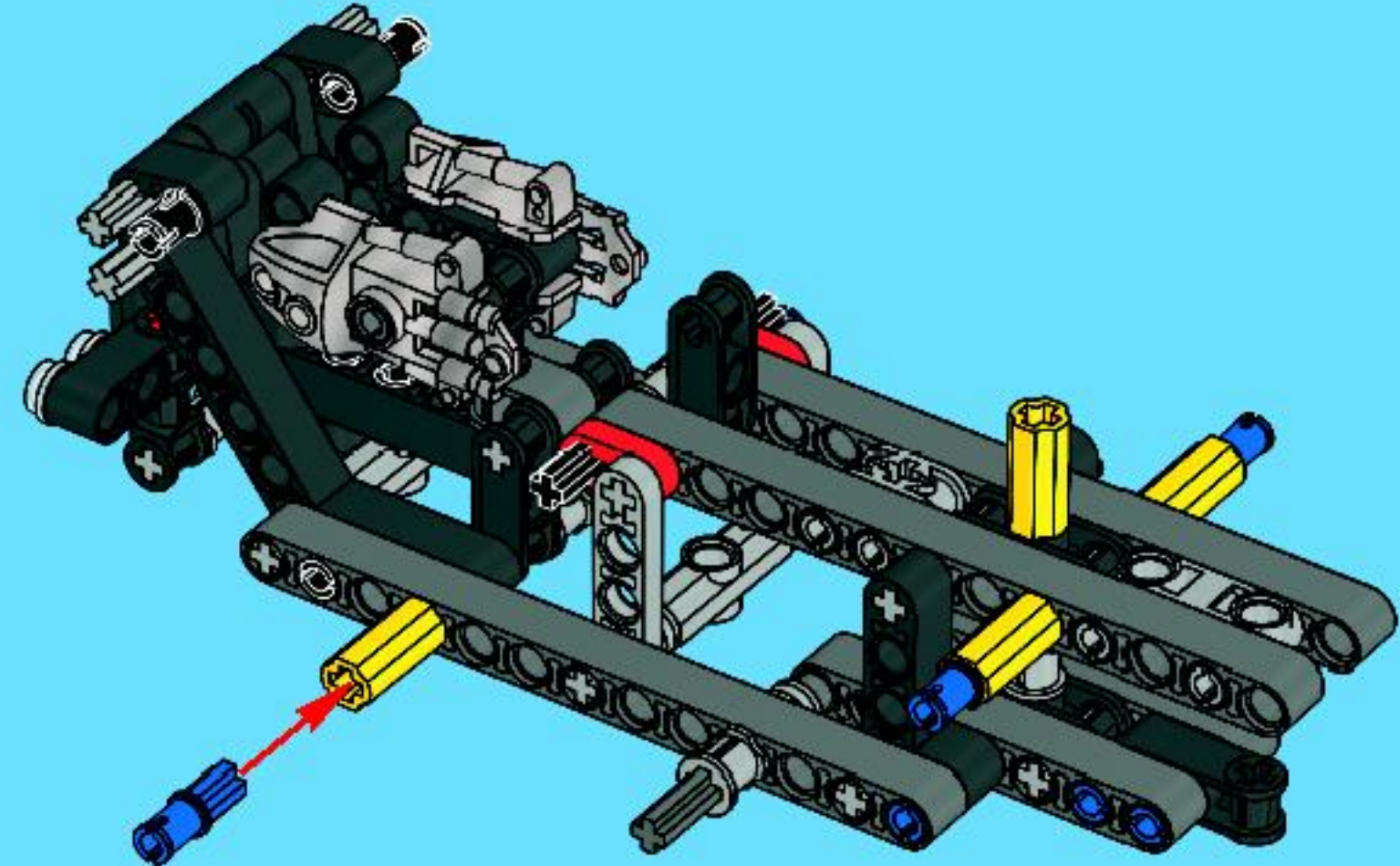

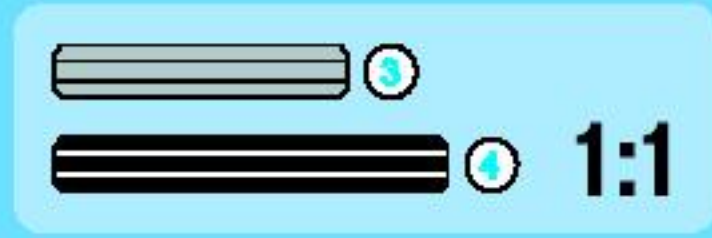

21

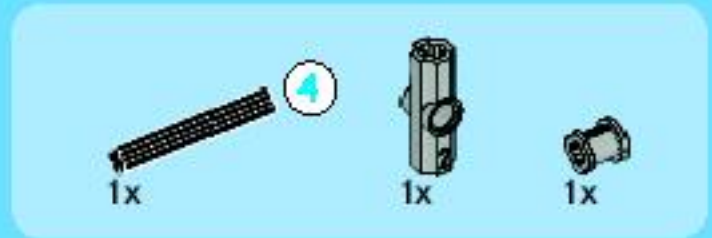
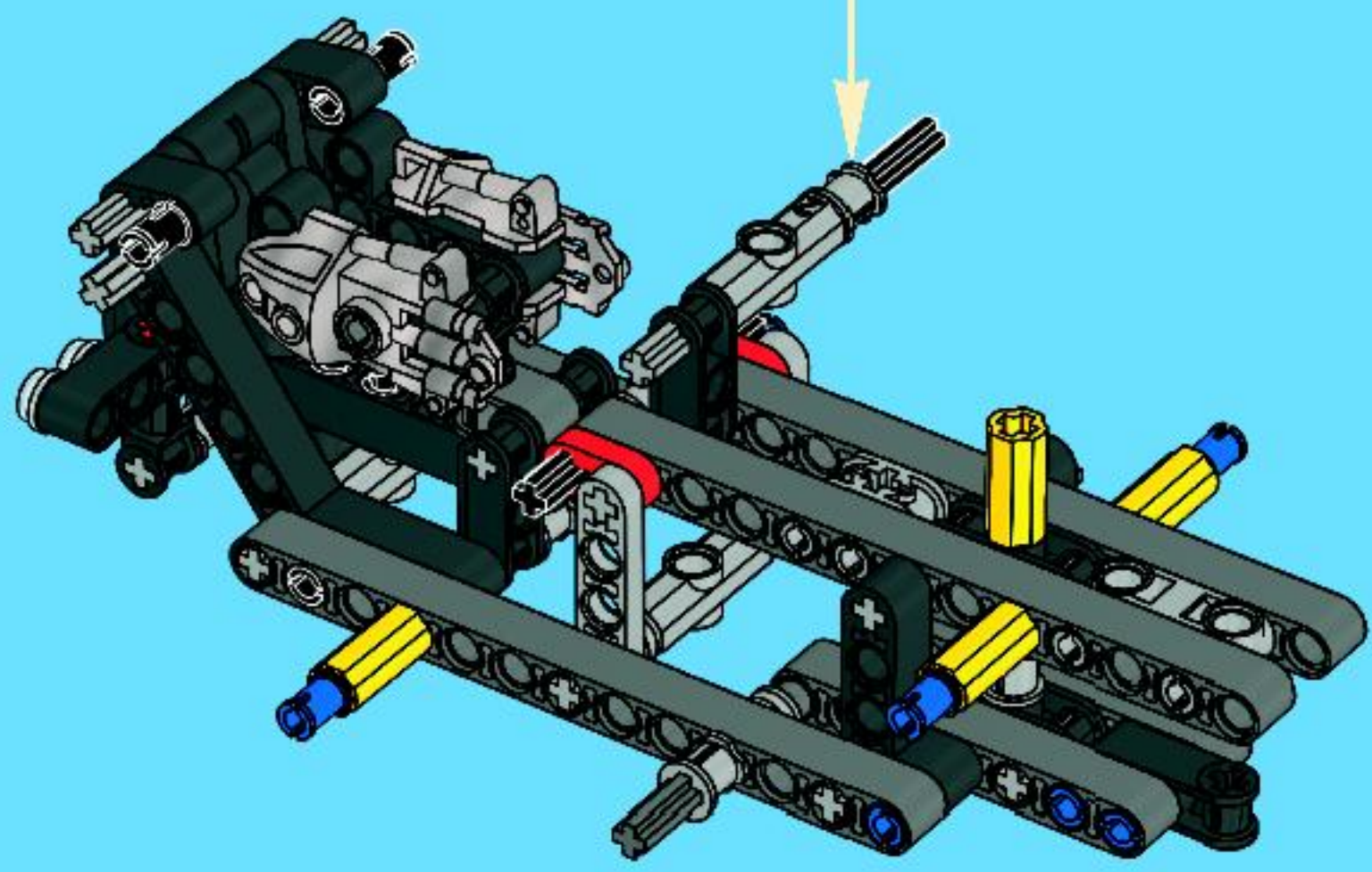
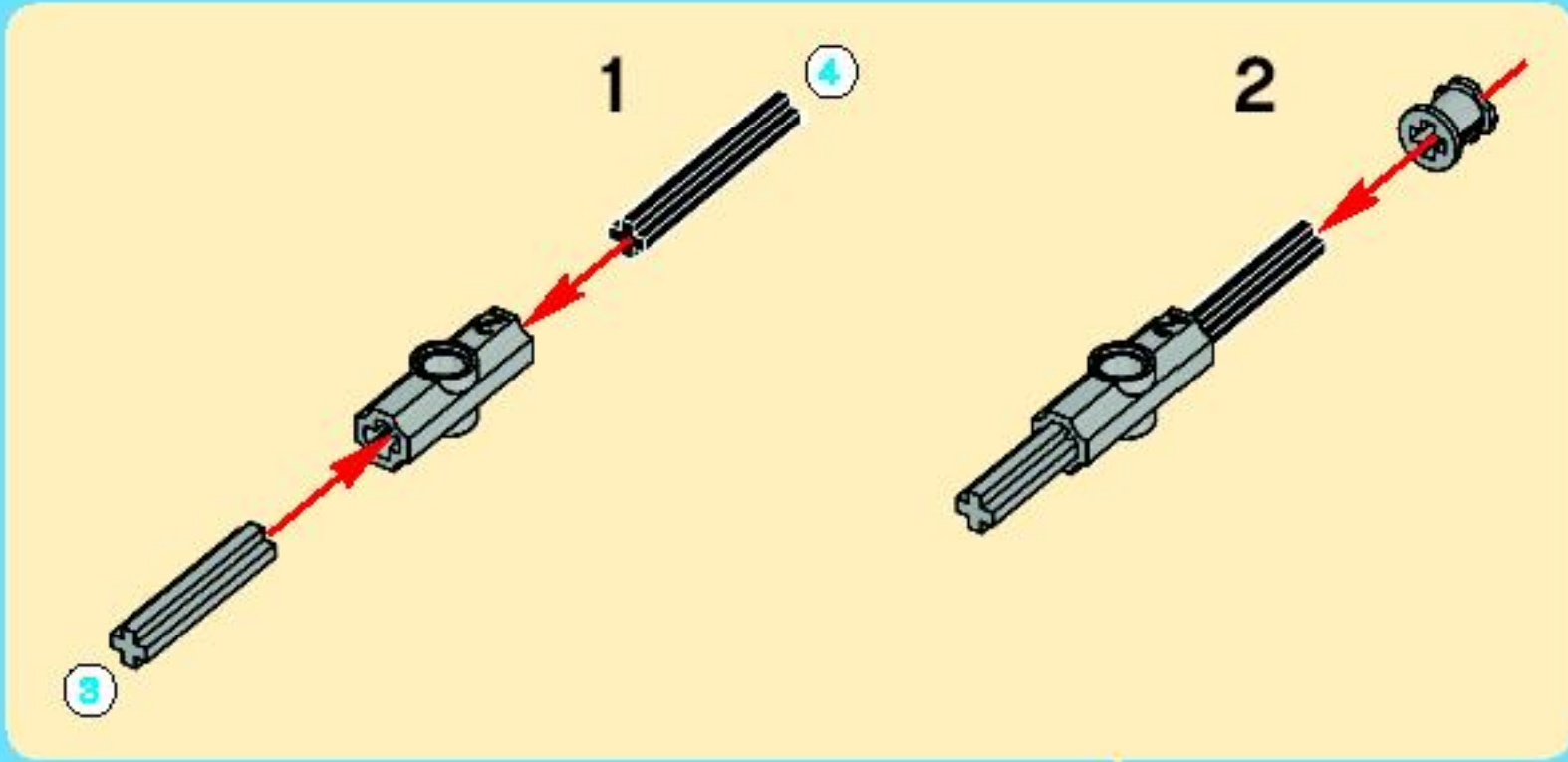

22

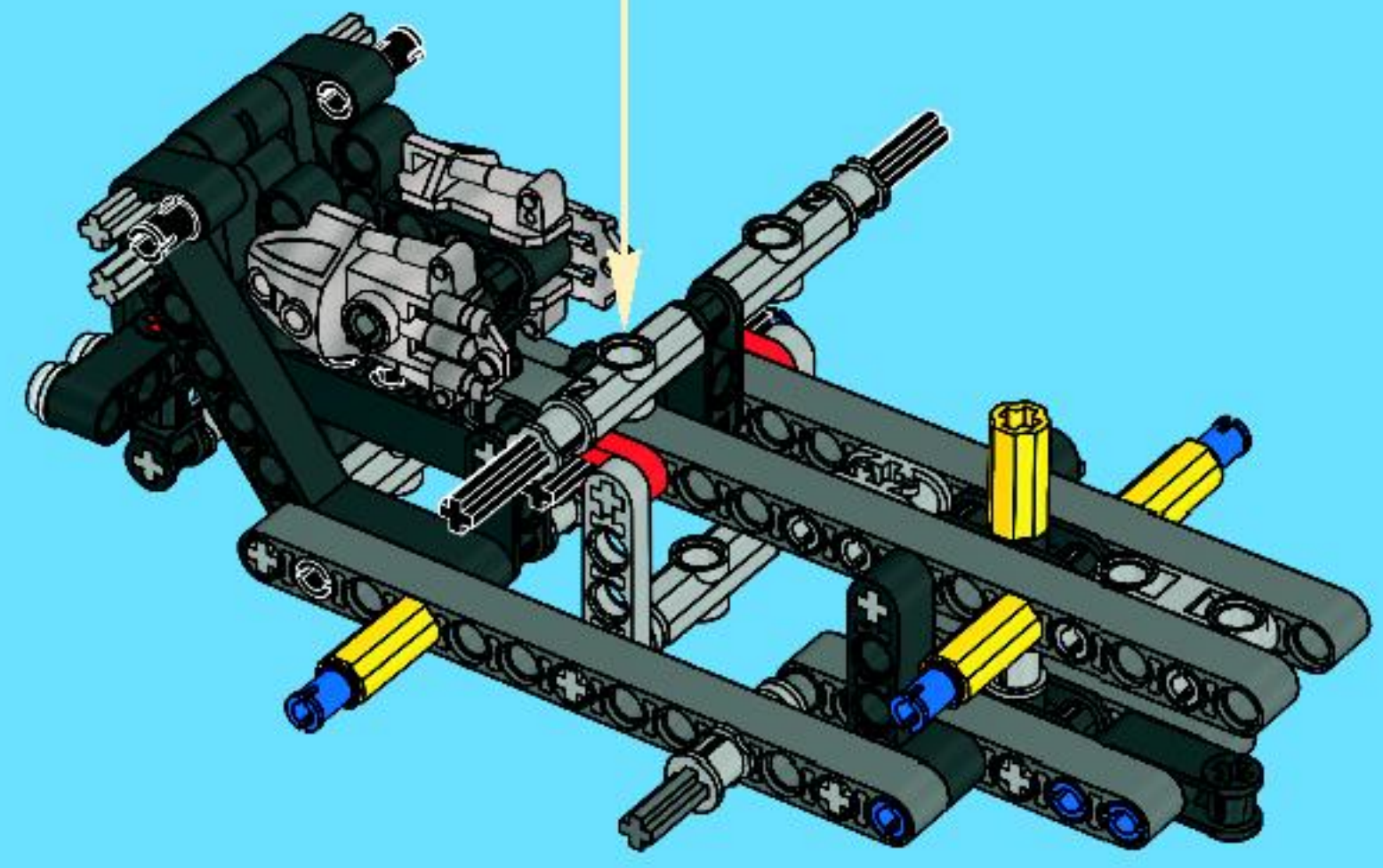
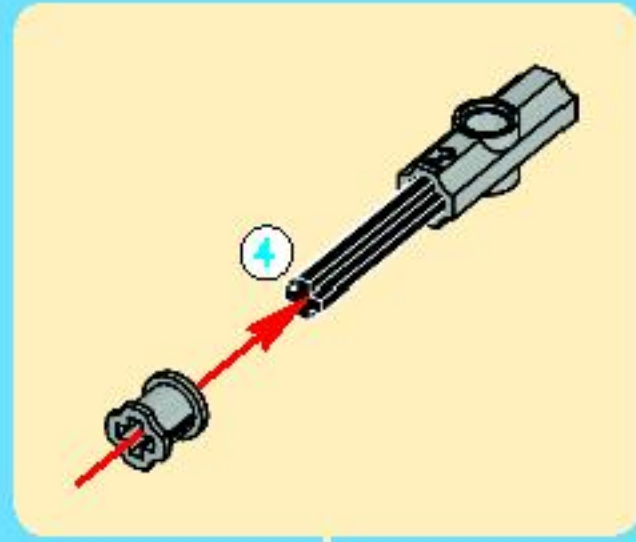

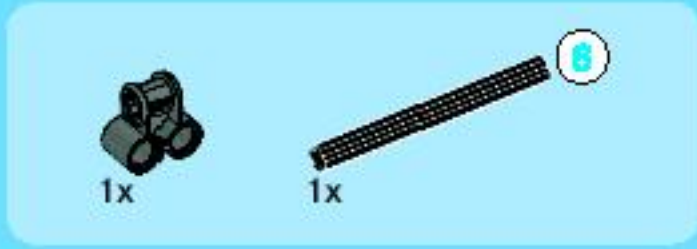
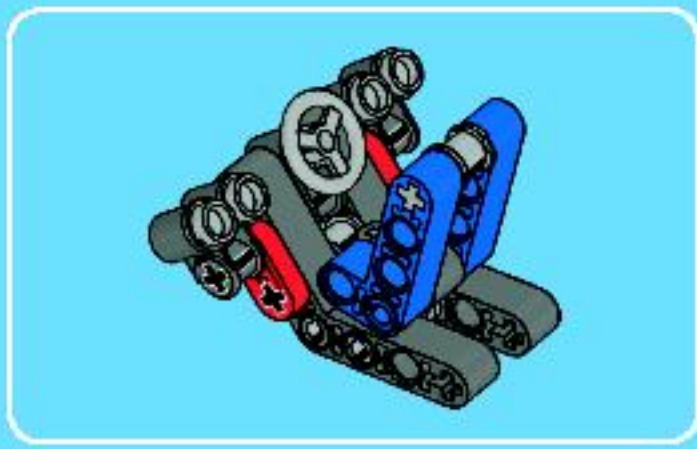

1

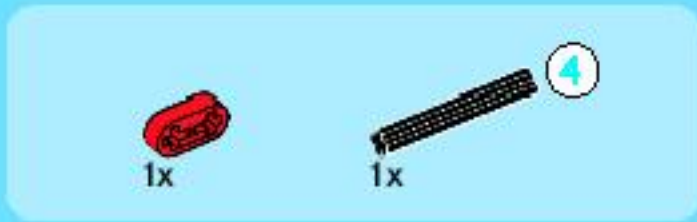

2

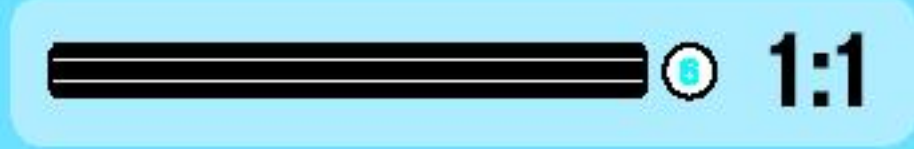

3

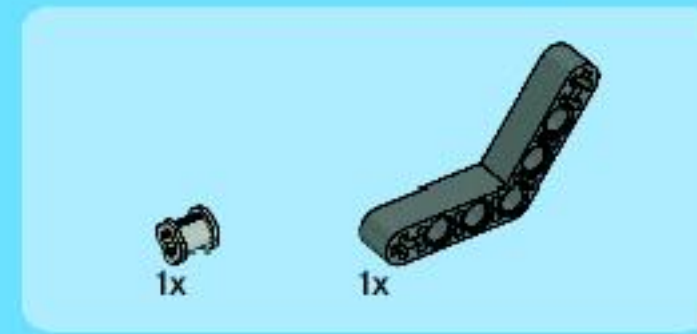

4

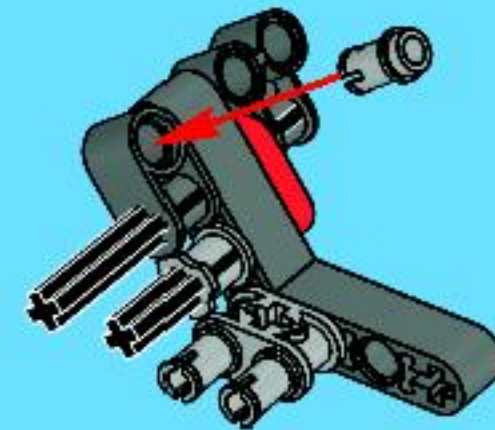
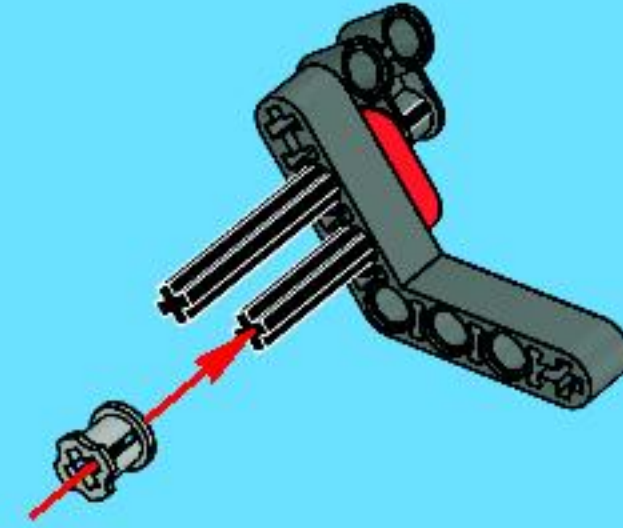

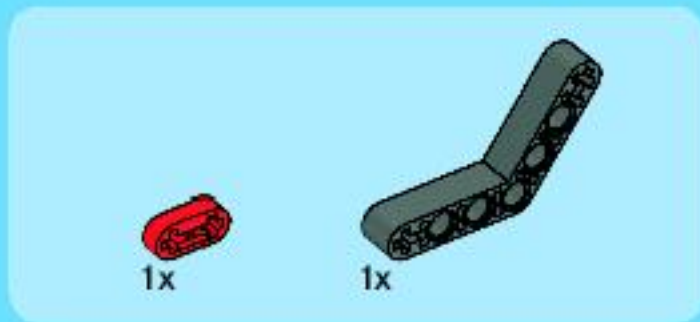

5

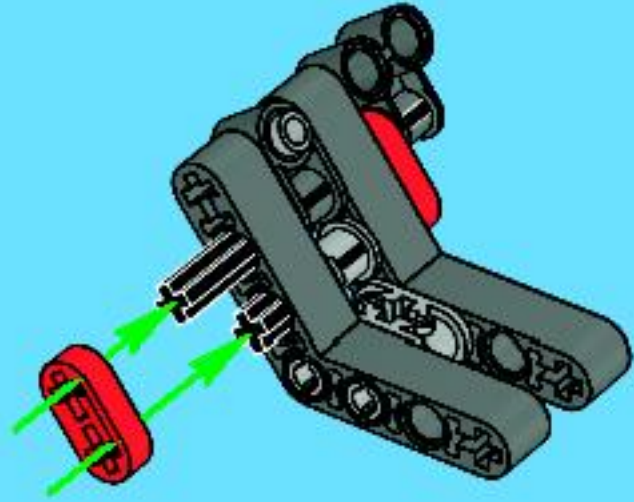

6

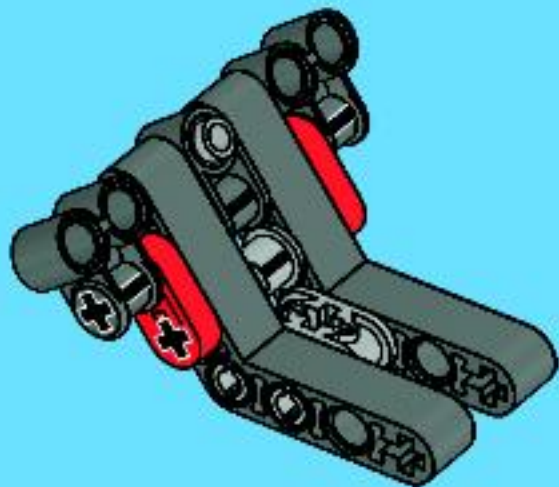

7

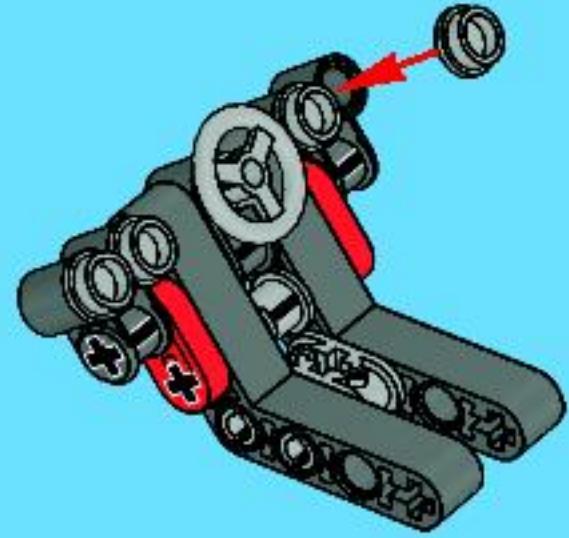

8

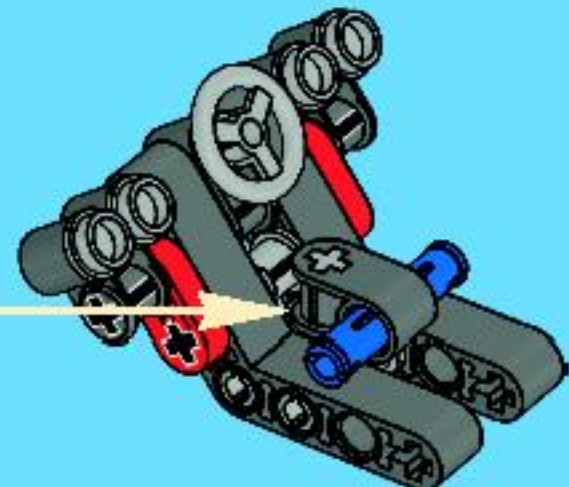
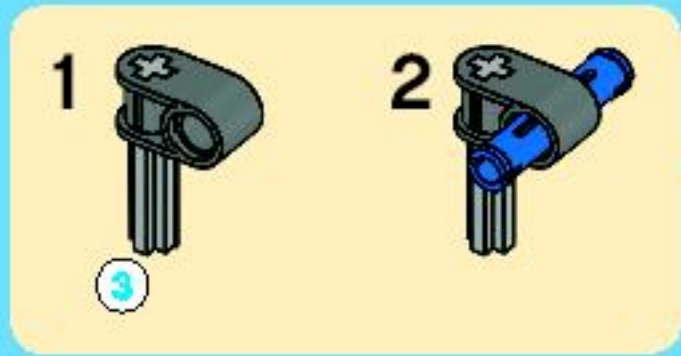



1x

9

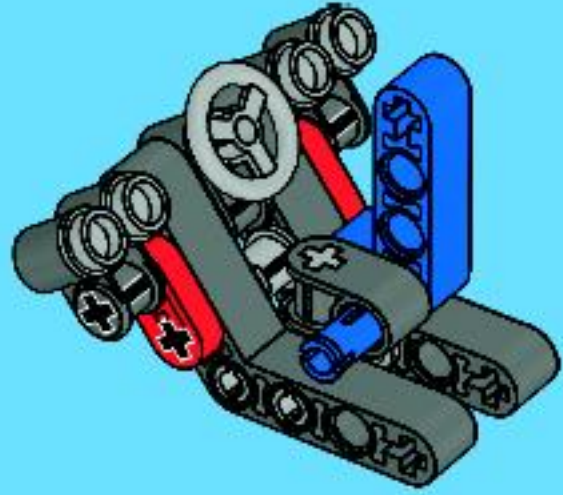

1x



1x



1:1

10

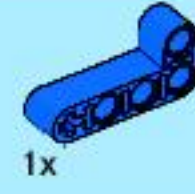
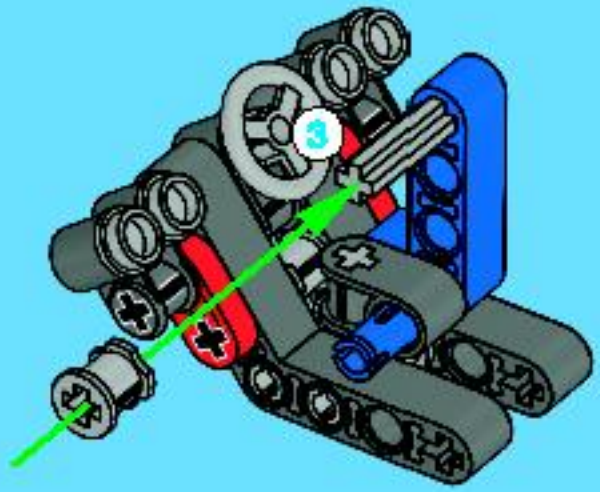

1x

11

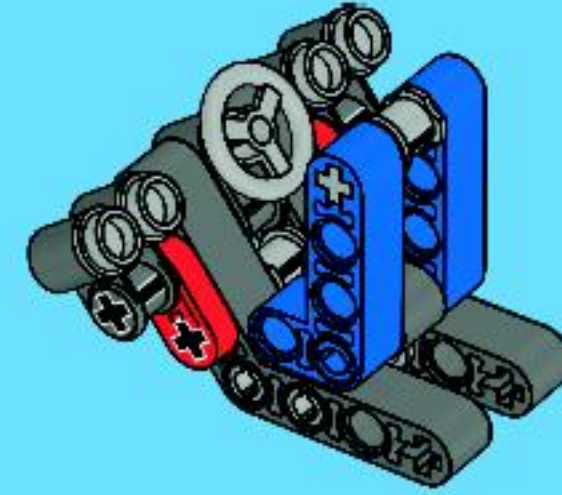

23

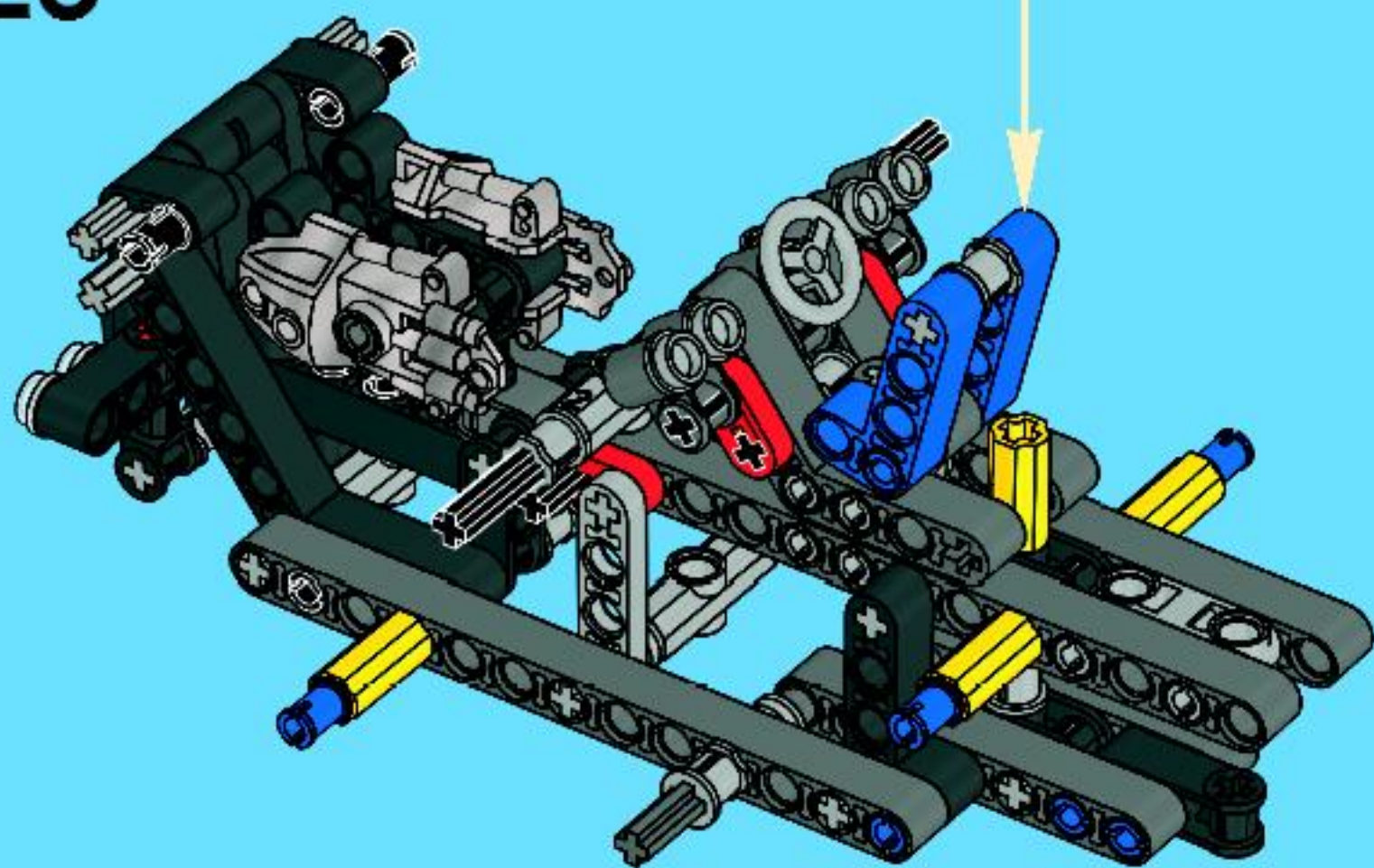

24

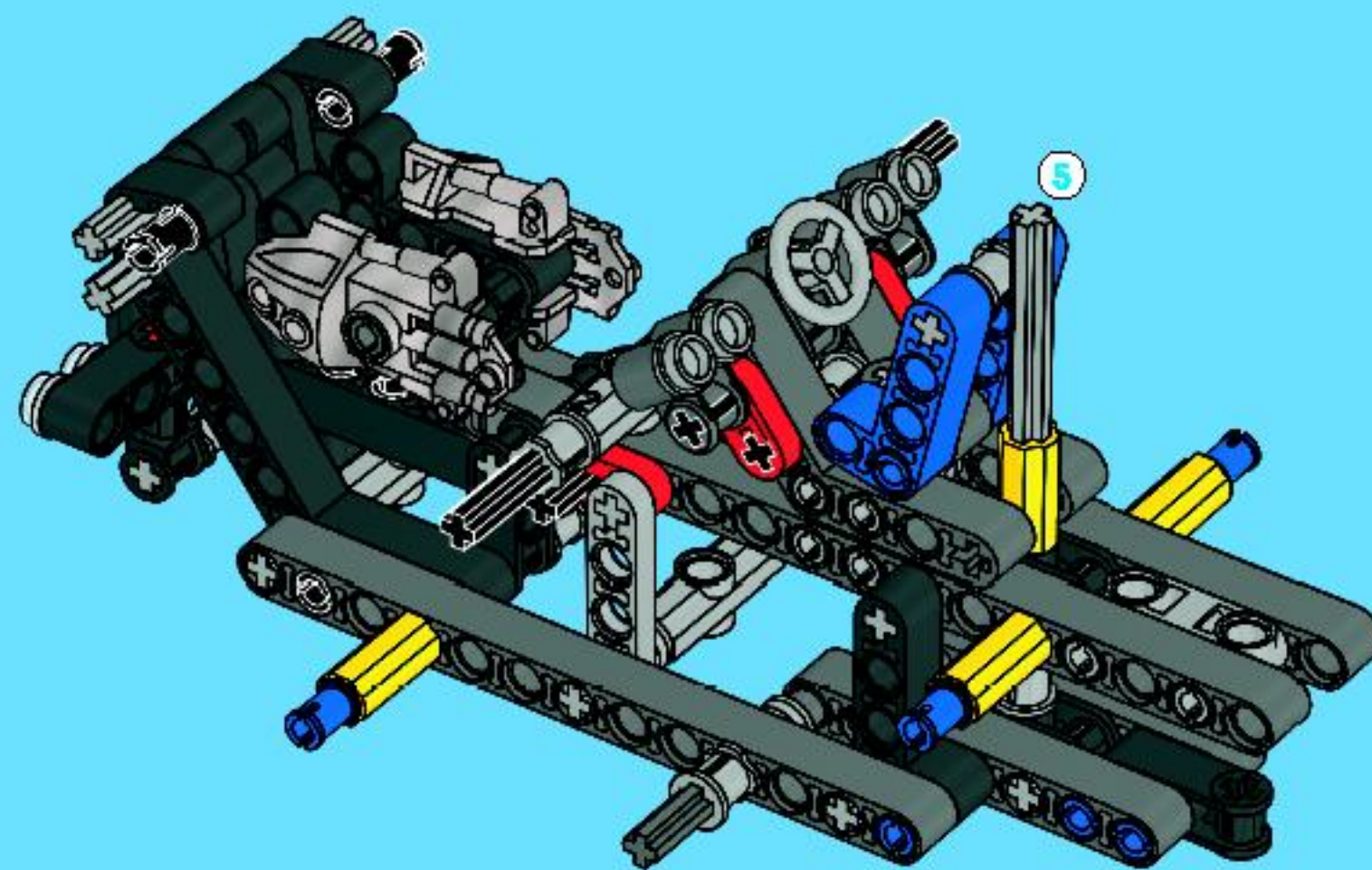
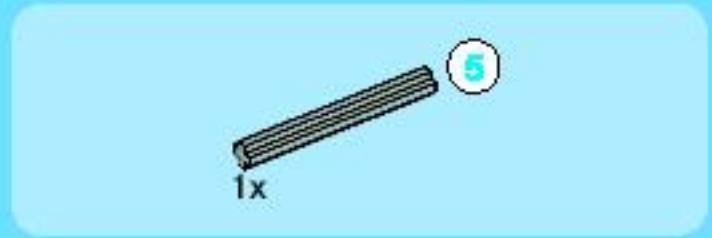



2x



1x



3x

3



3

1:1

25

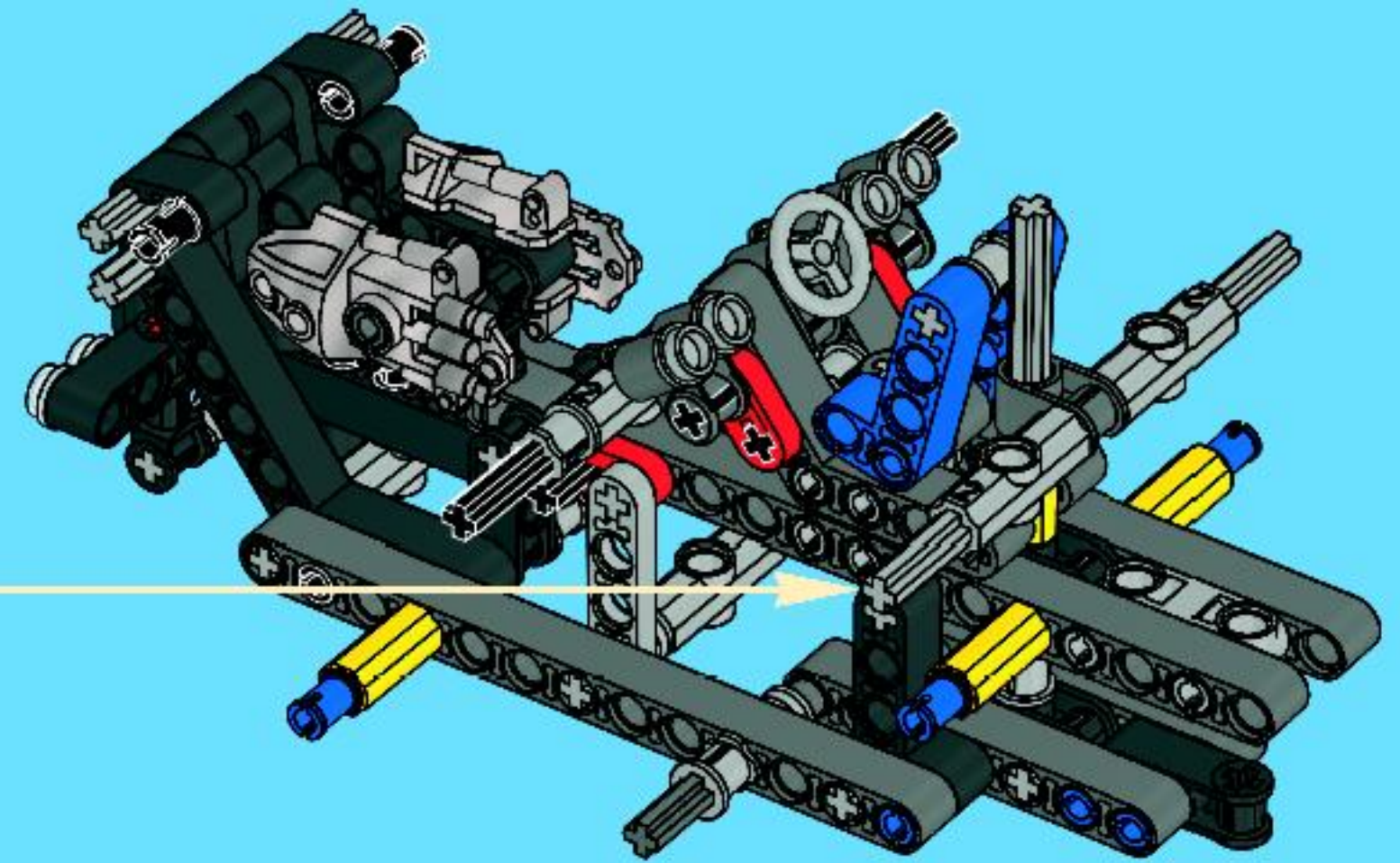
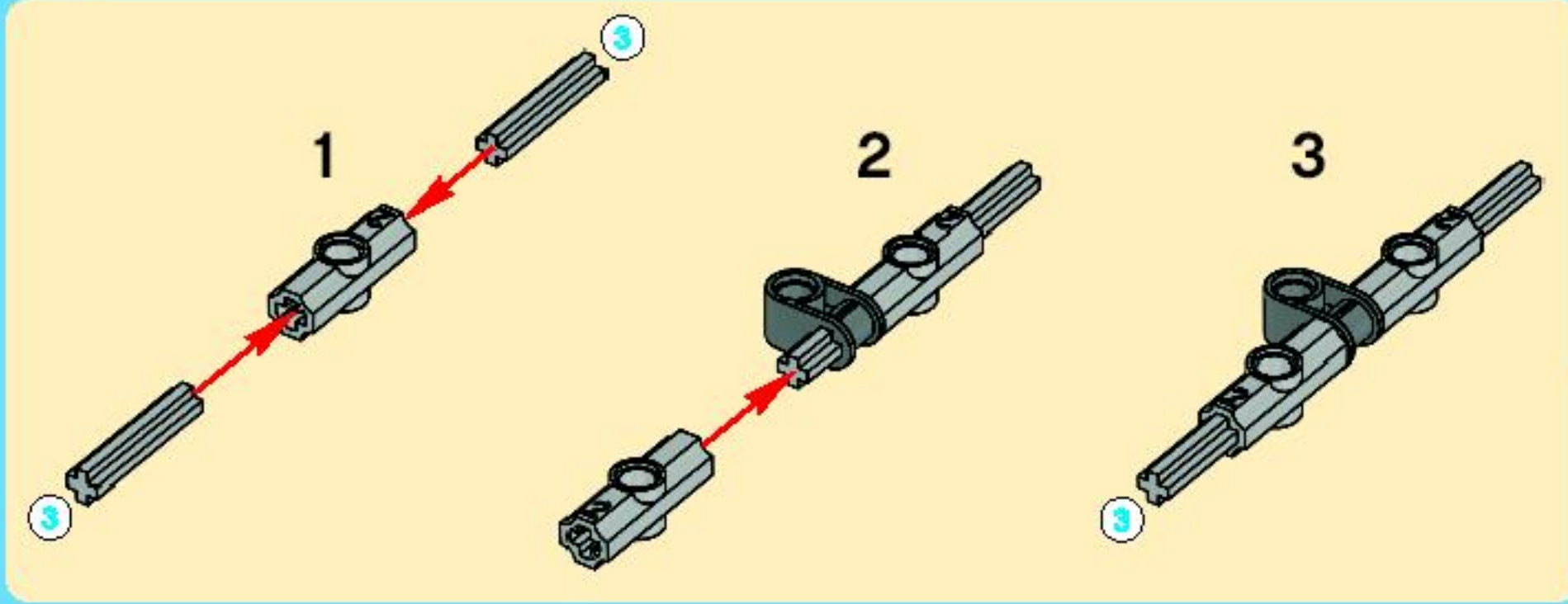

1x

26

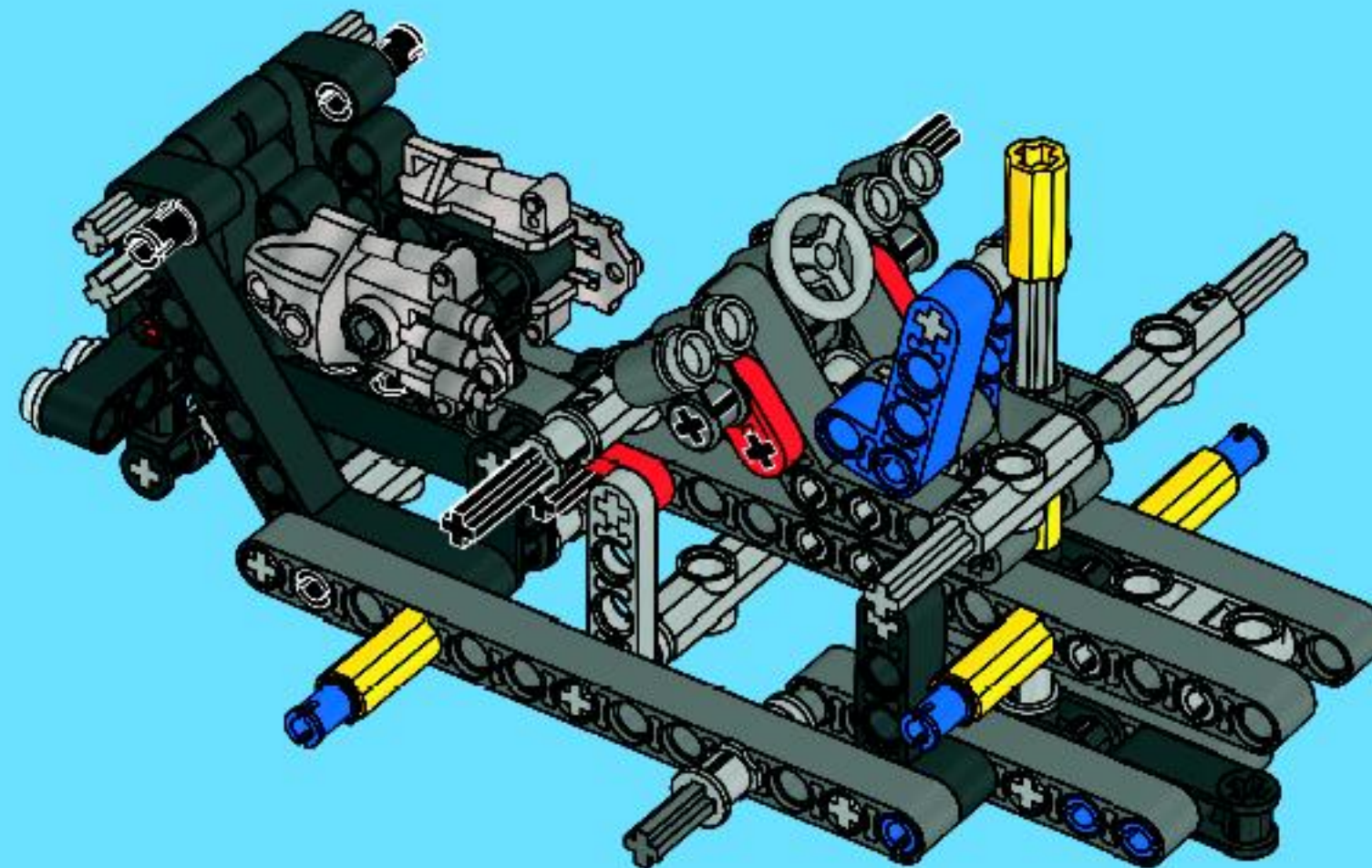

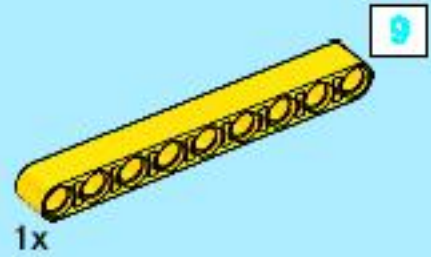
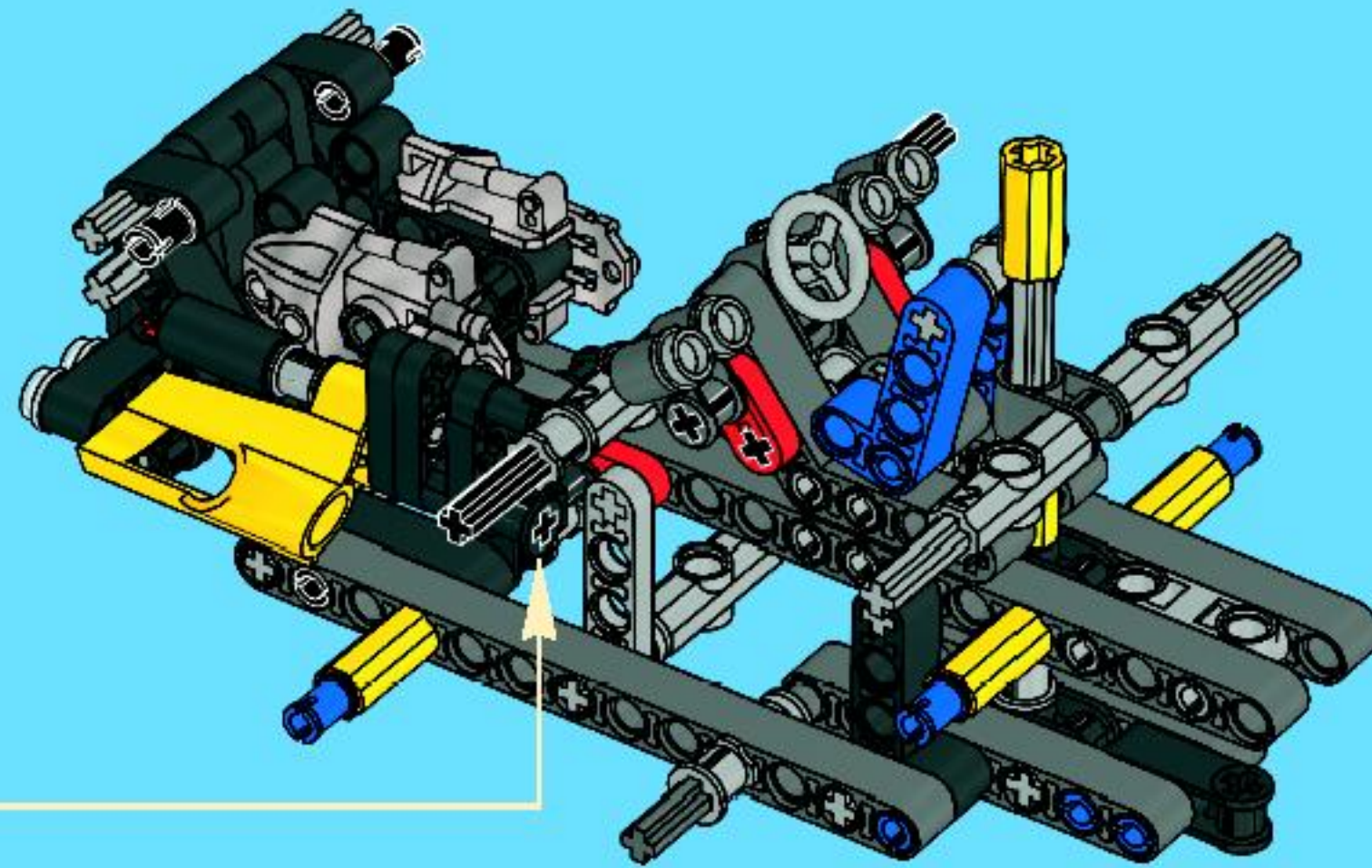

1x



28

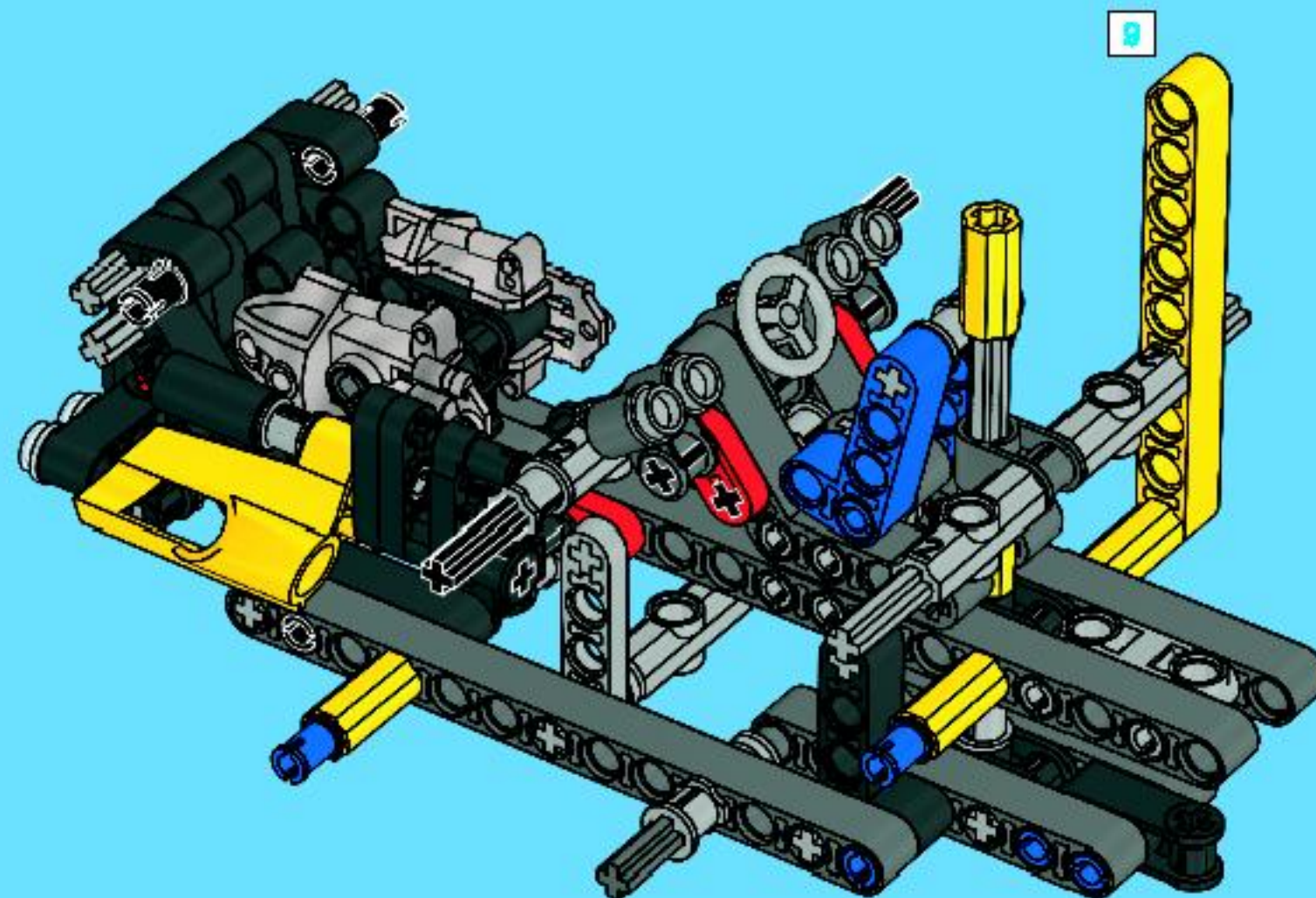

4x

29

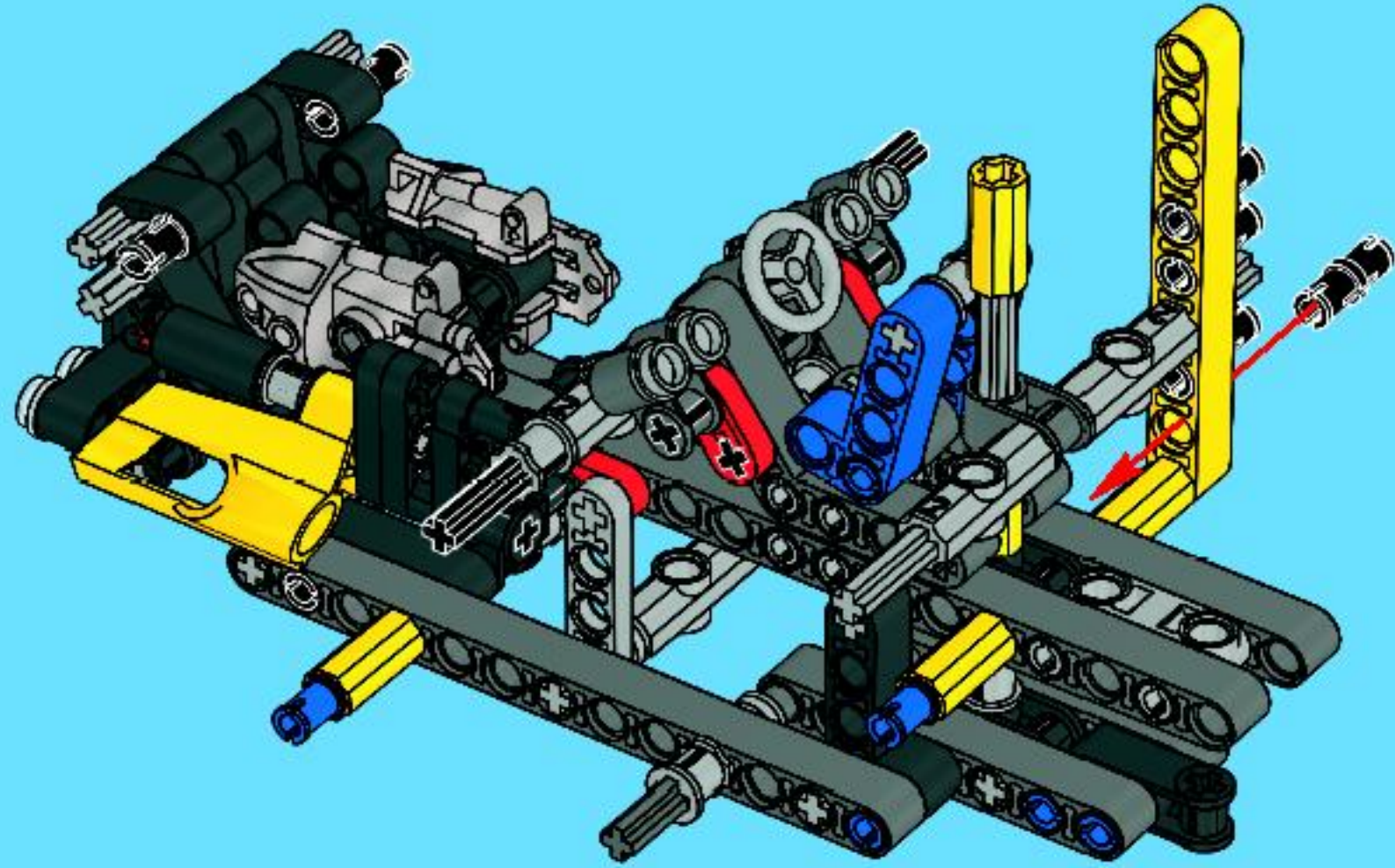

1x

30

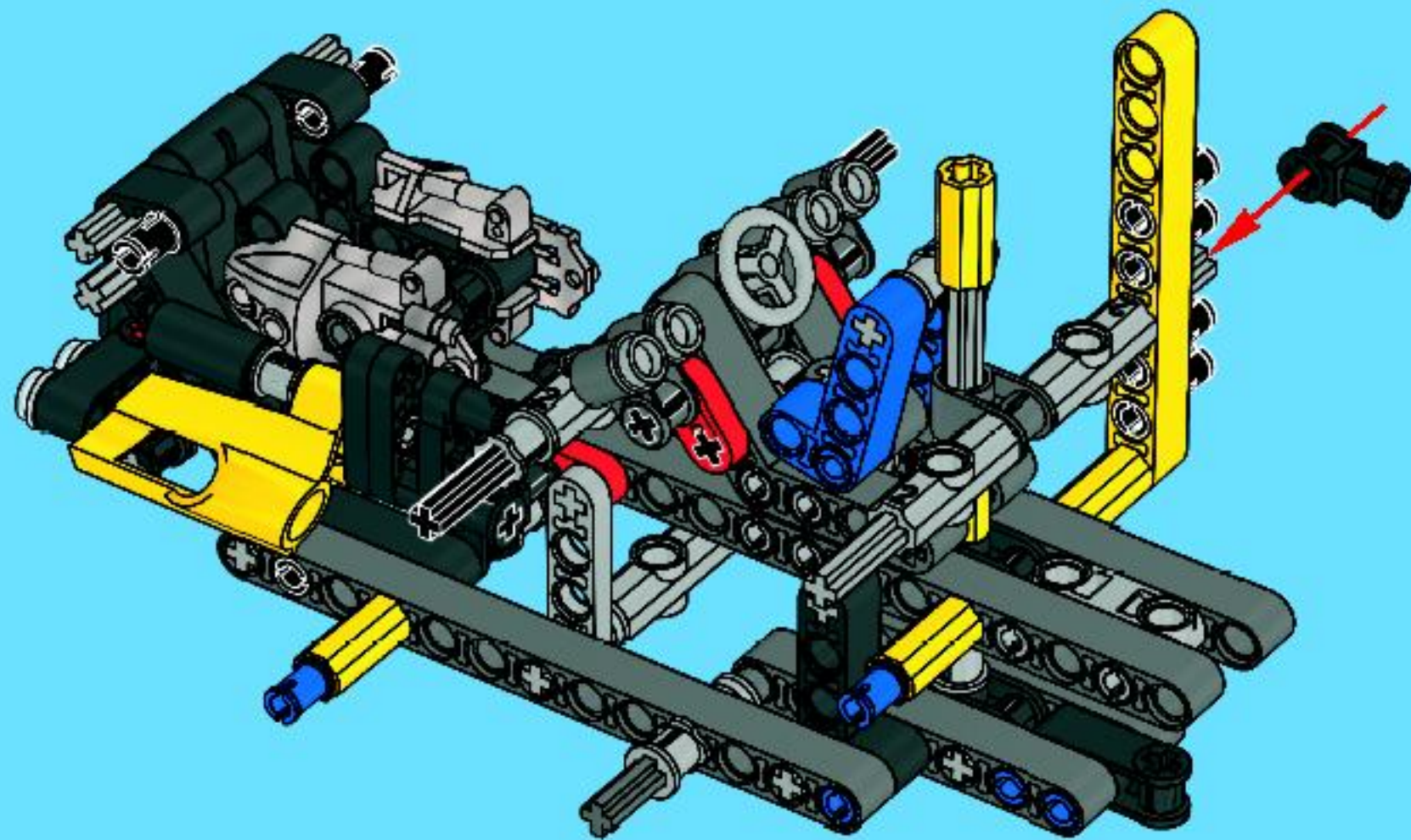

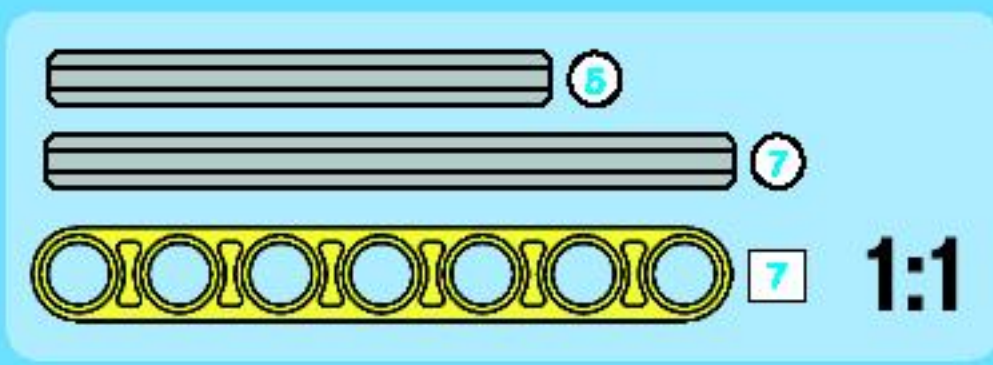
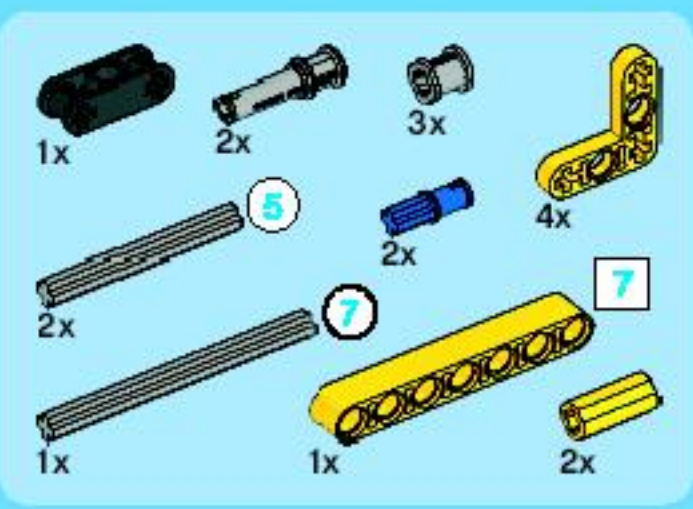

31

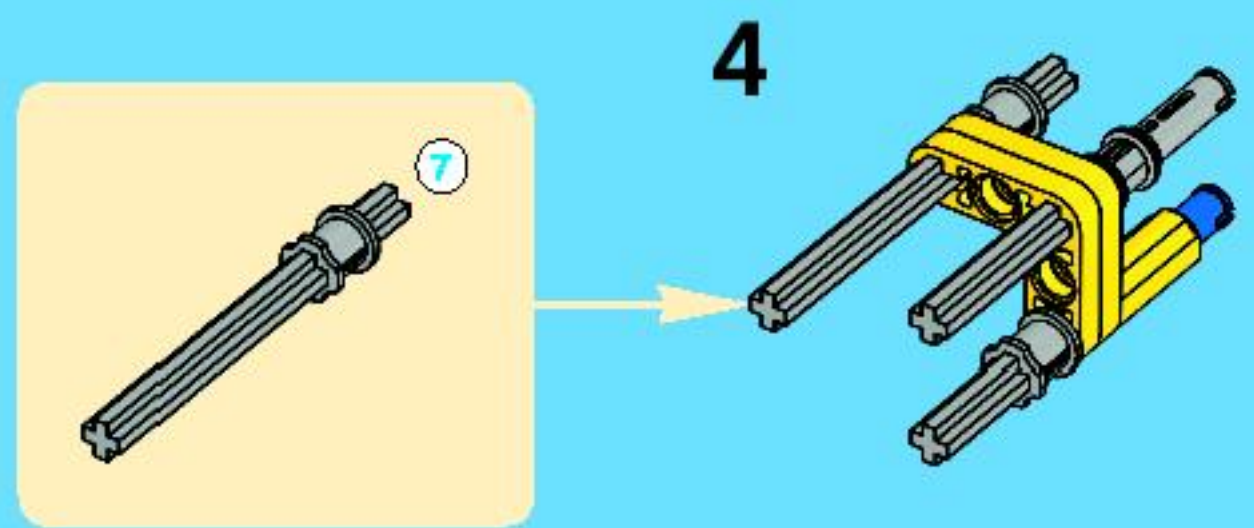
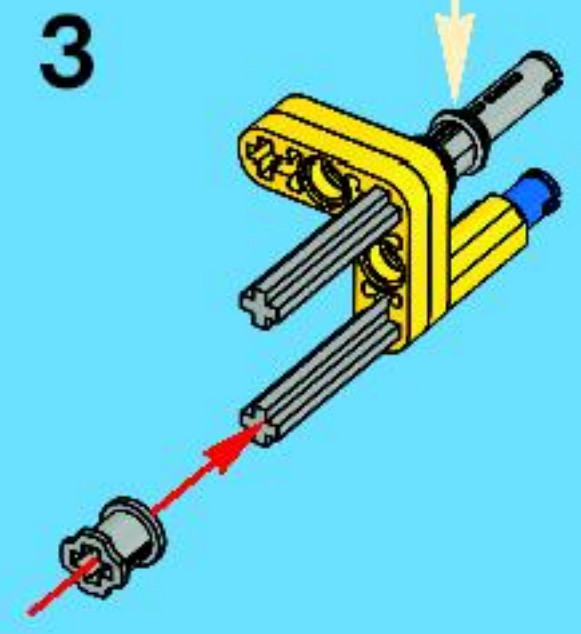
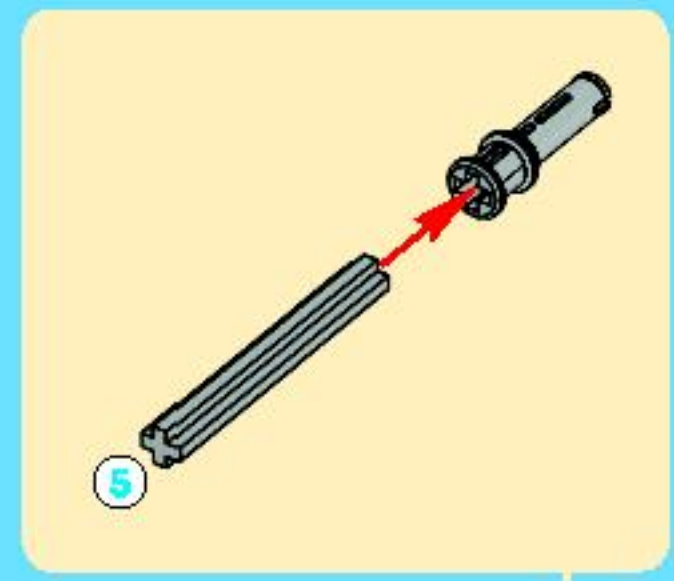
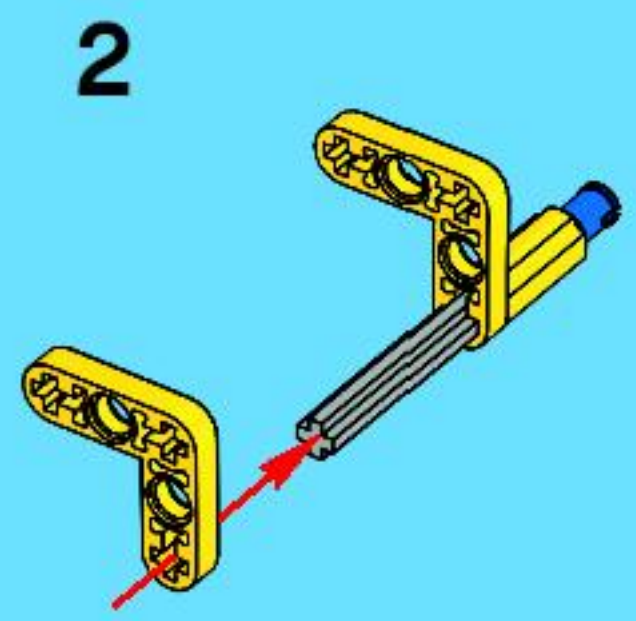
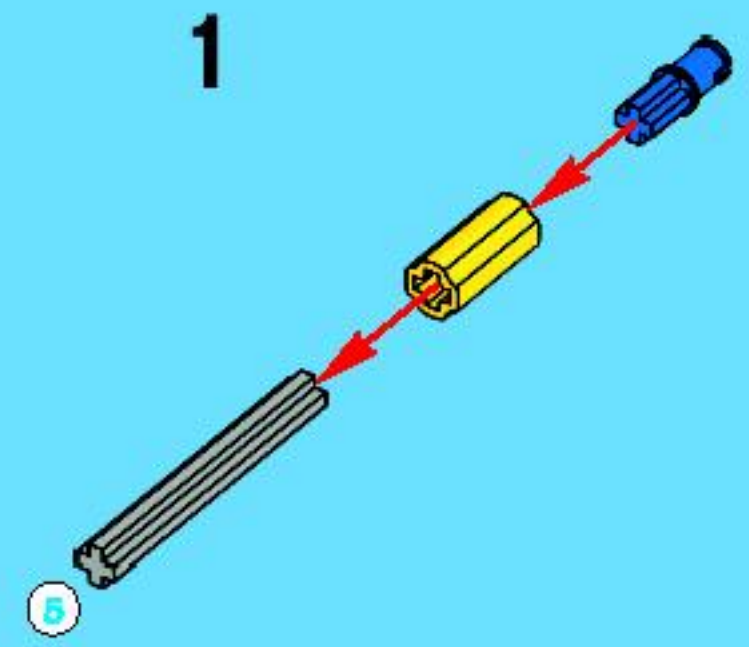

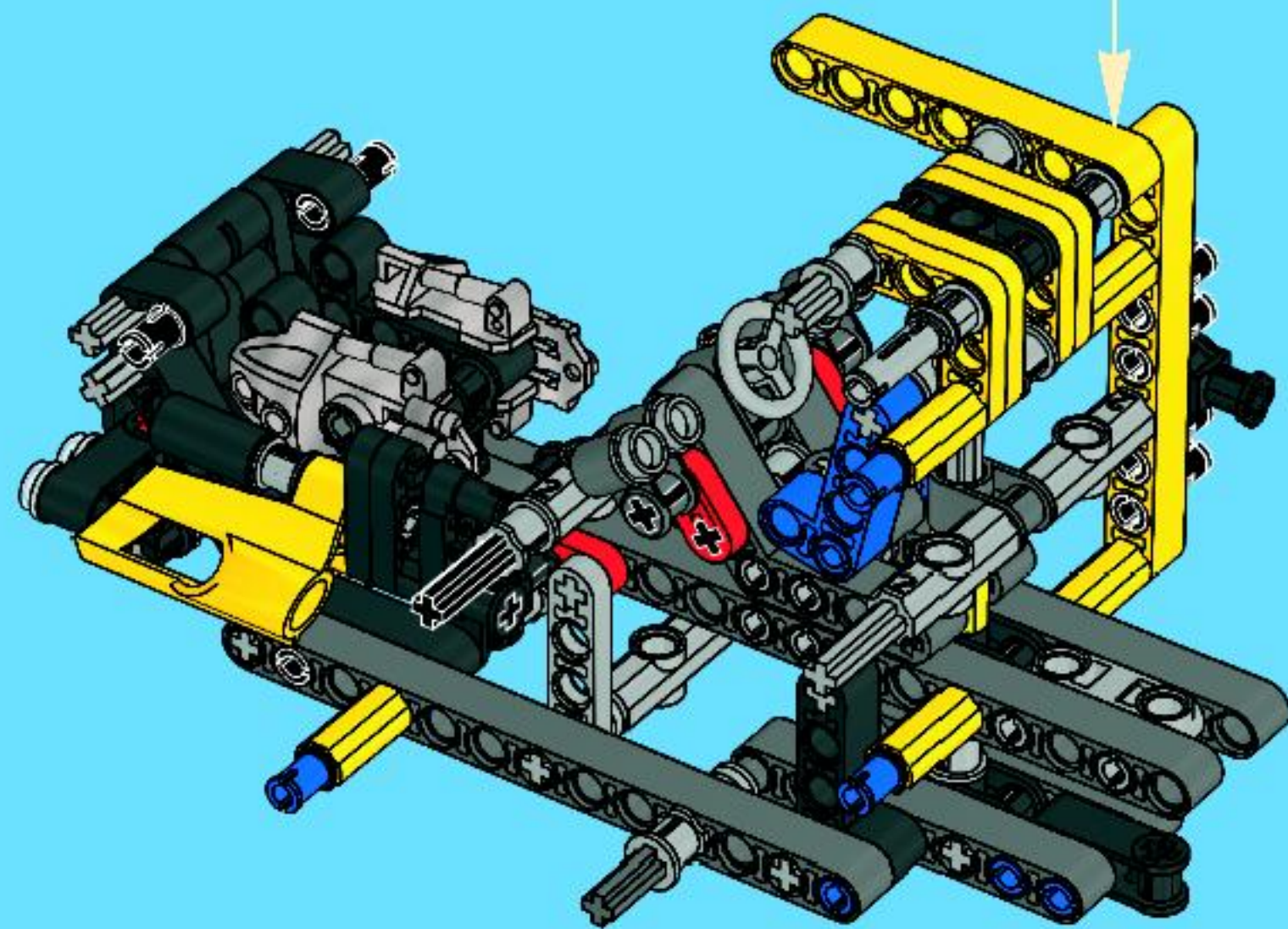
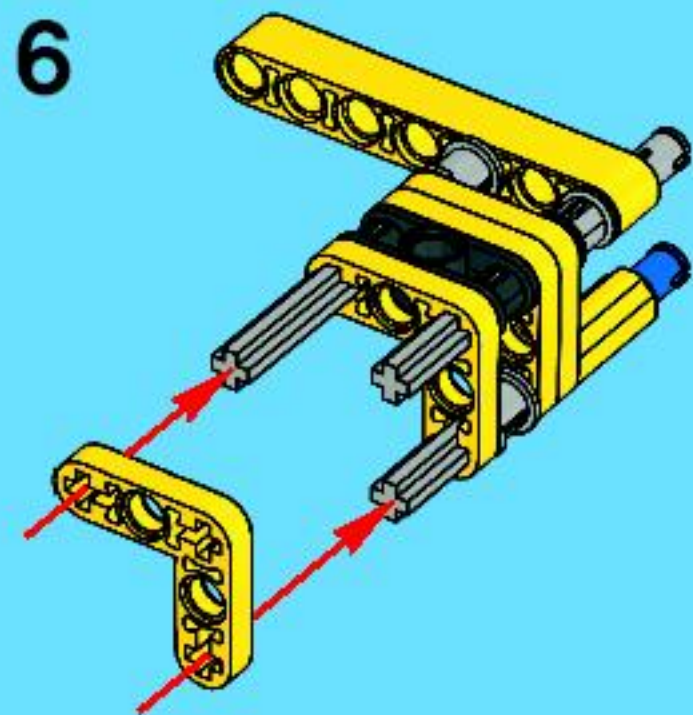
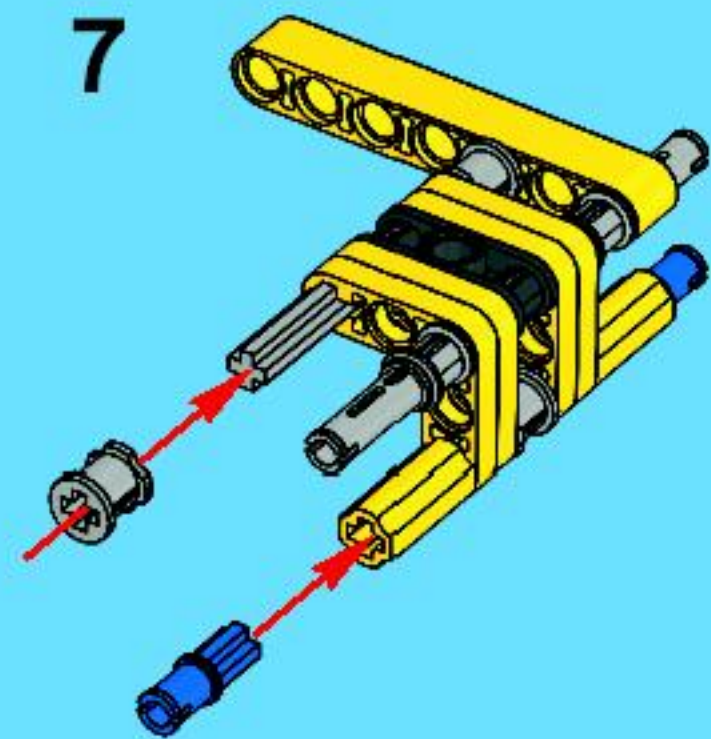
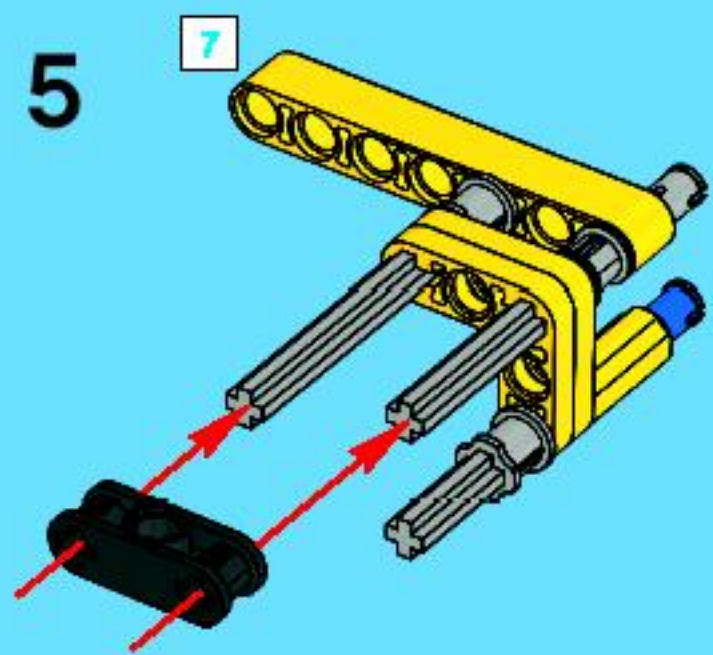



32

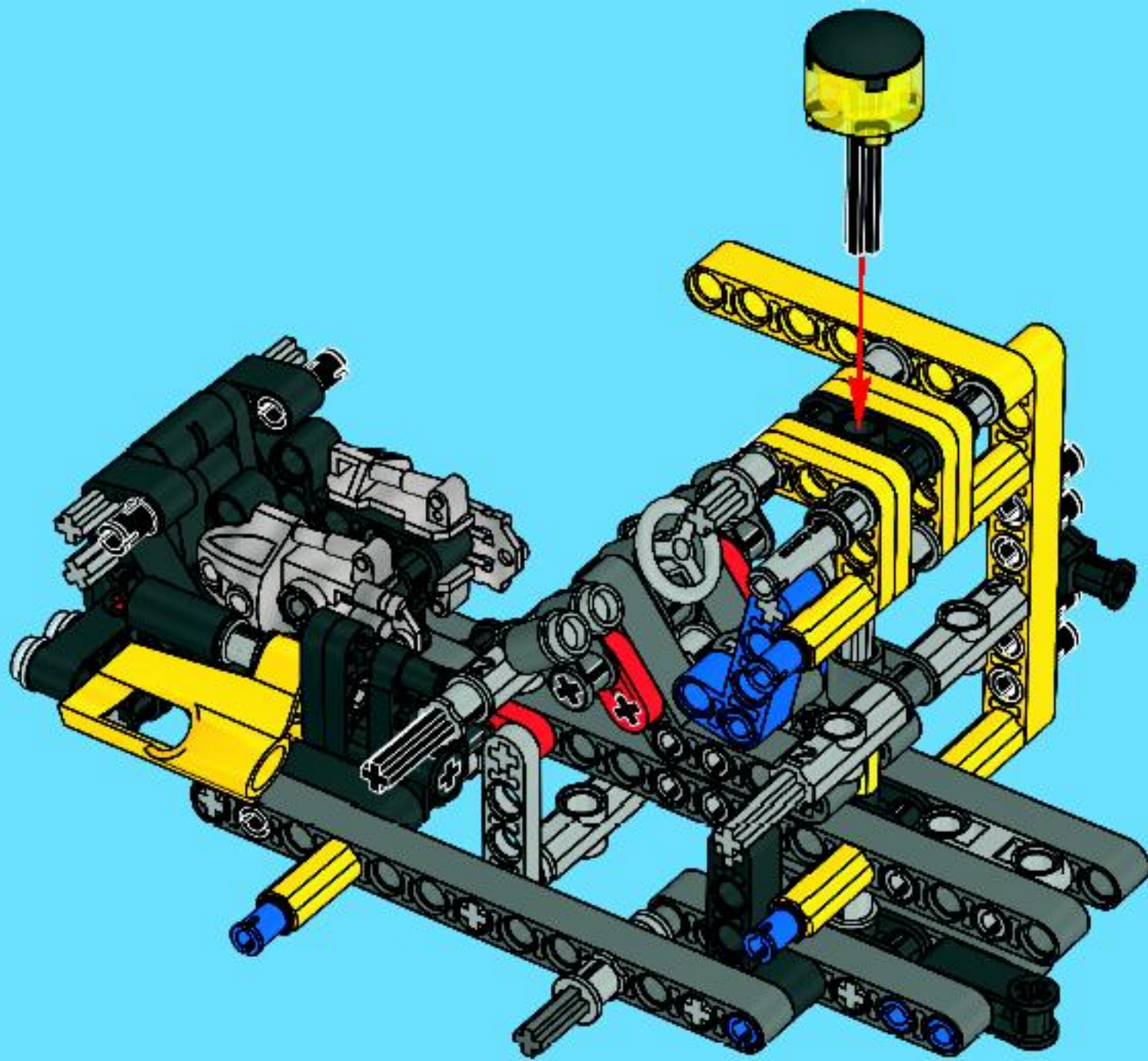
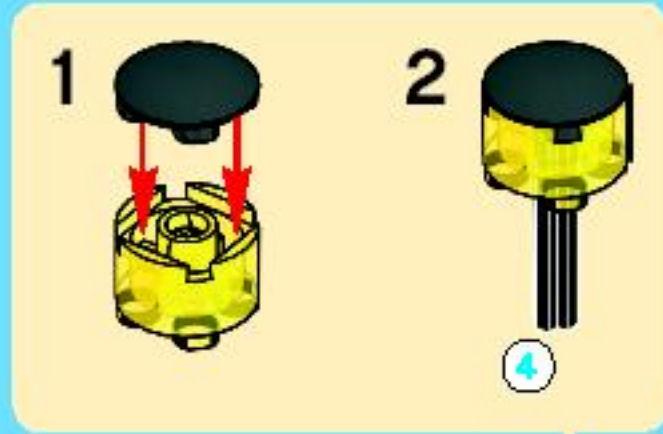

33

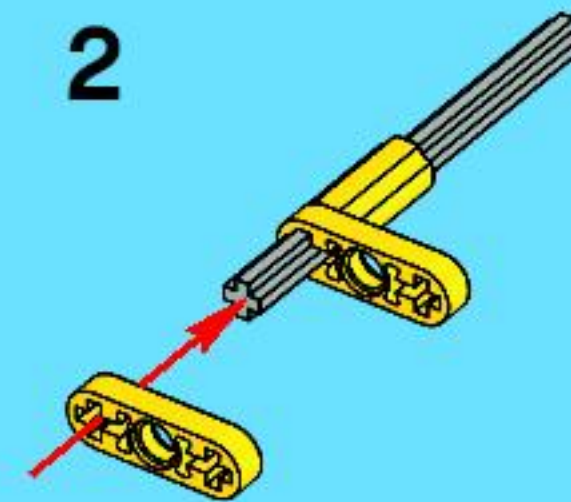
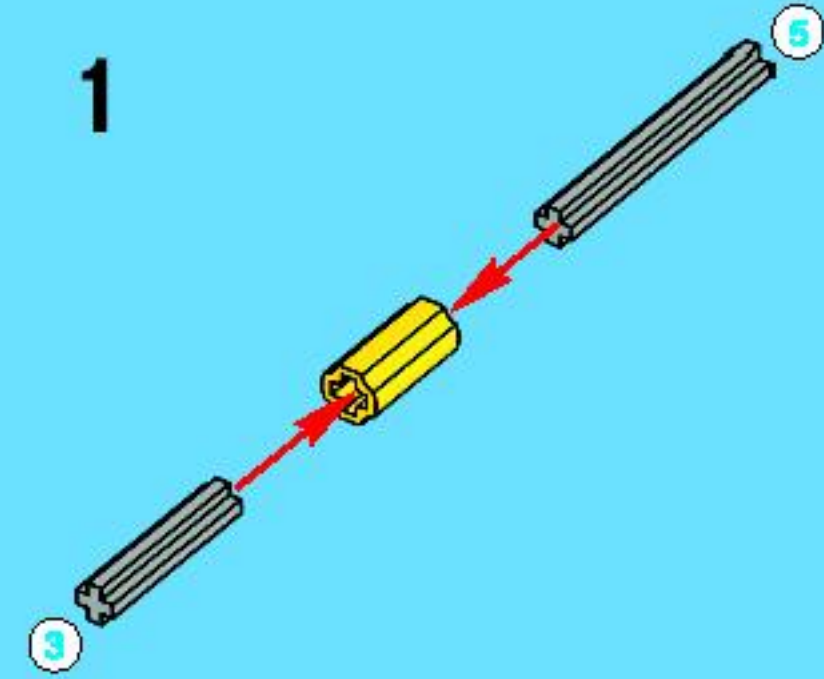

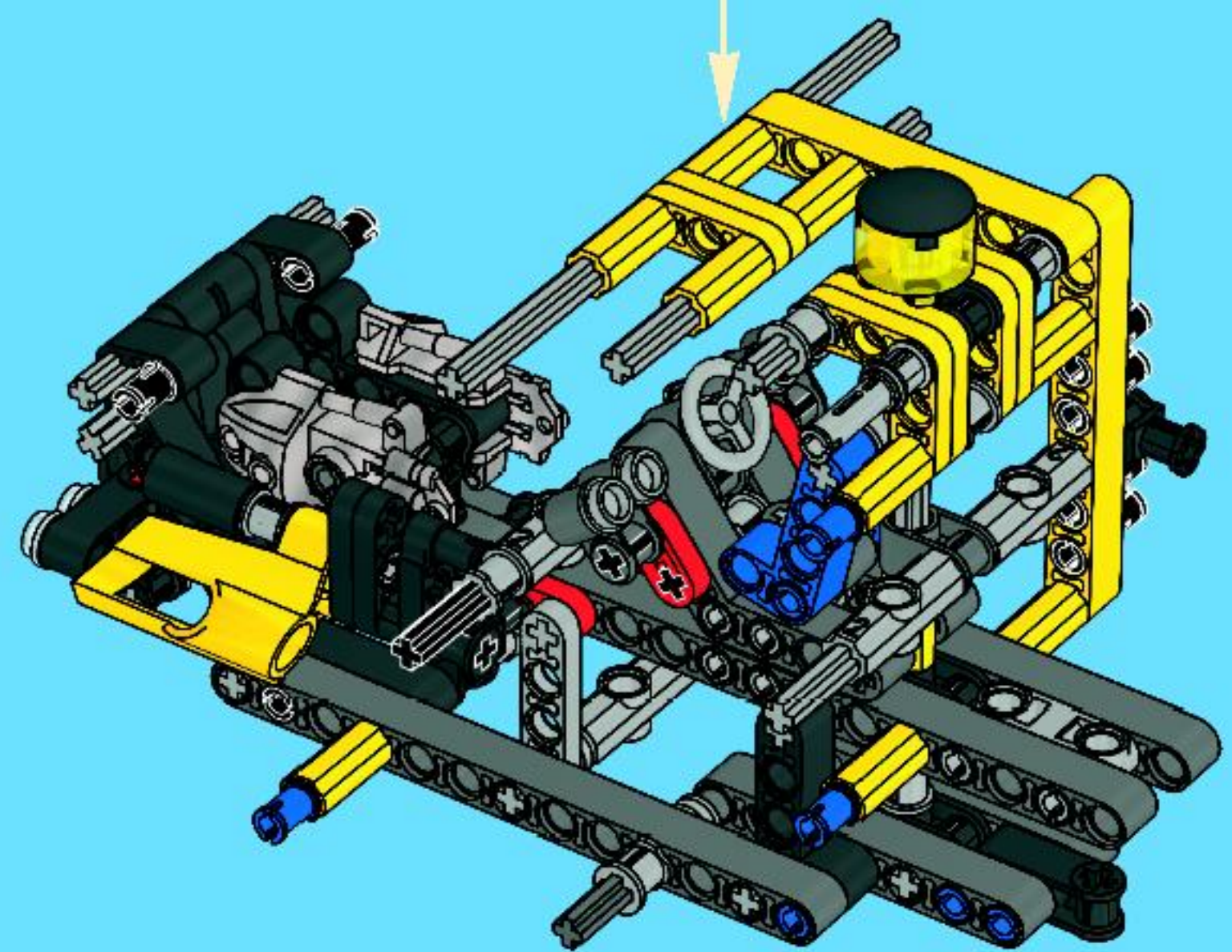
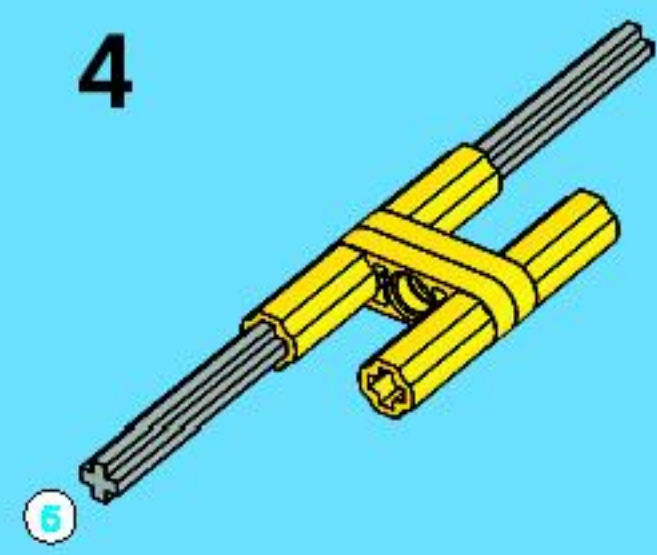
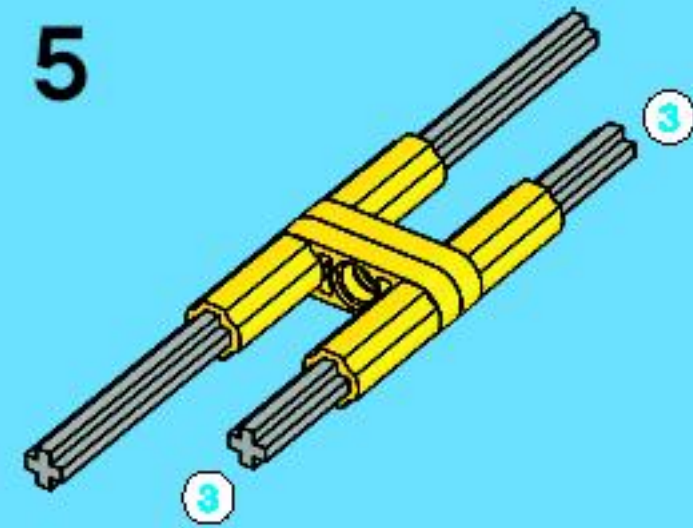
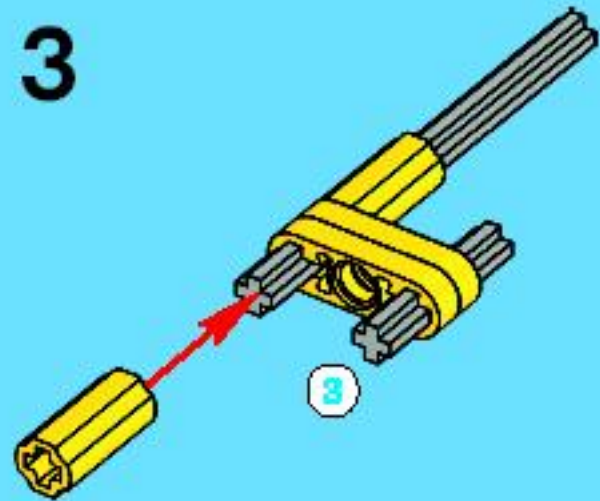

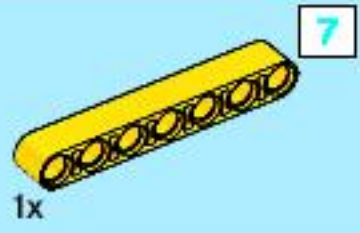

34

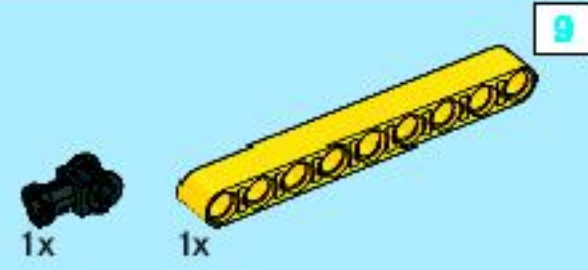
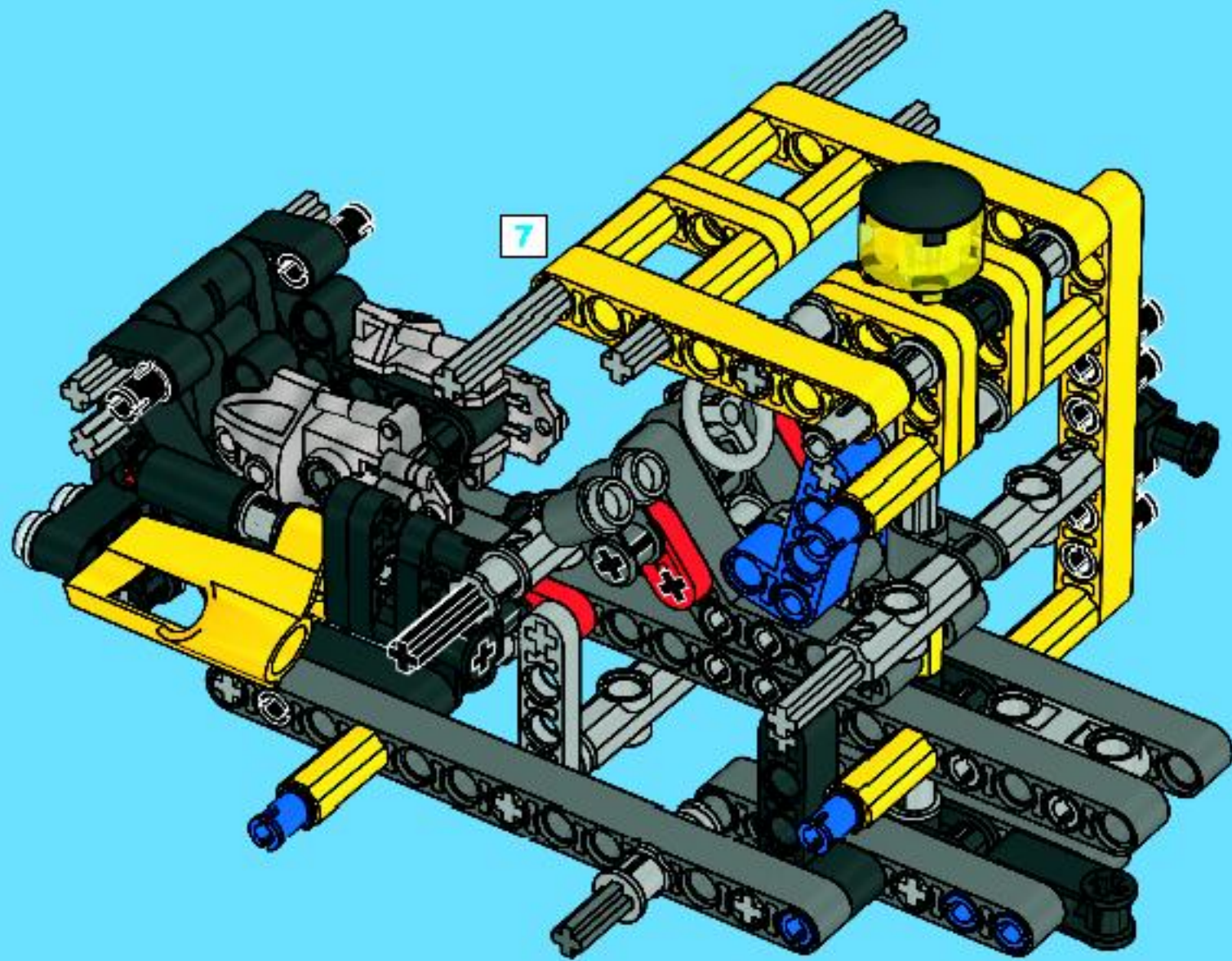

35

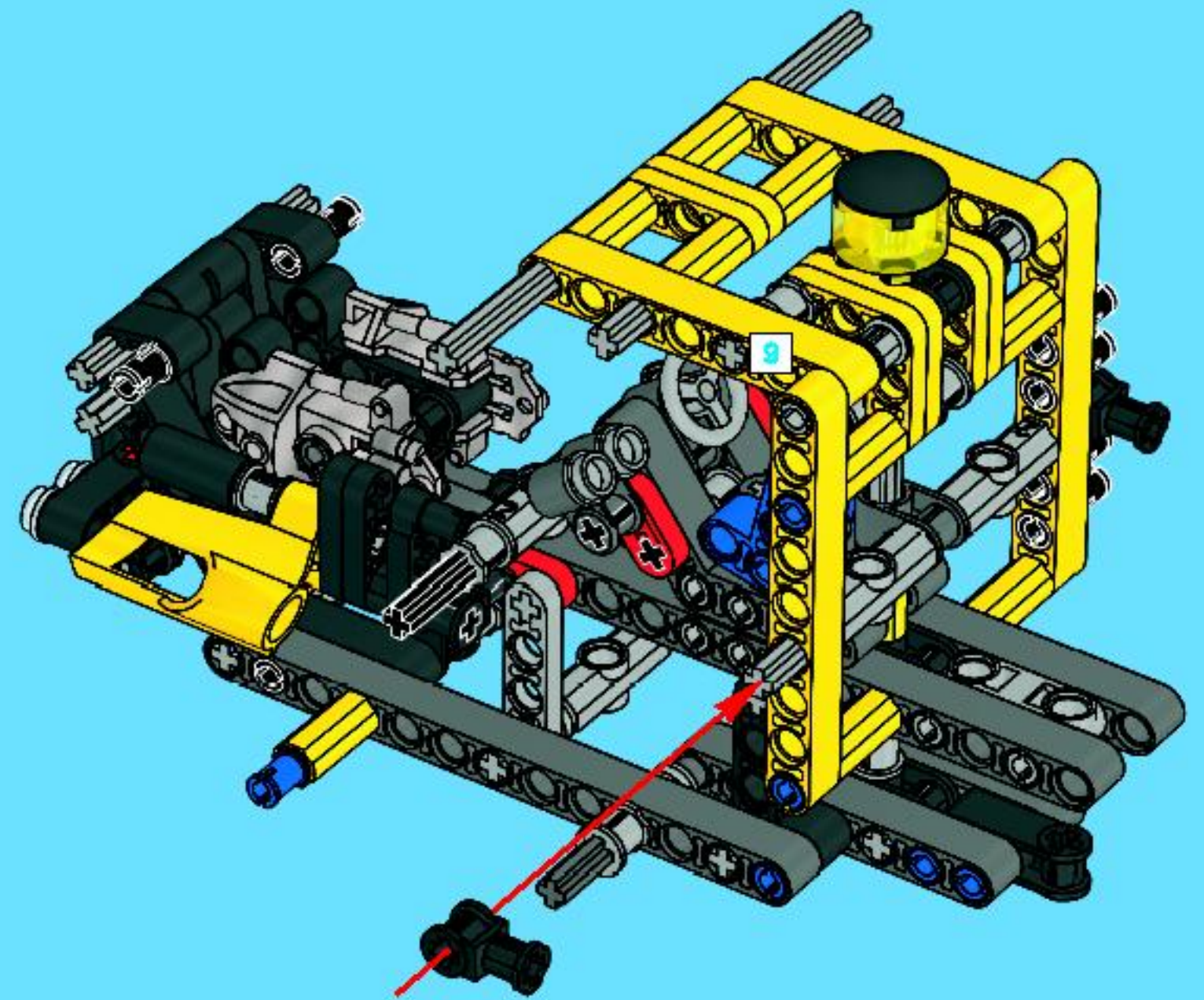



36

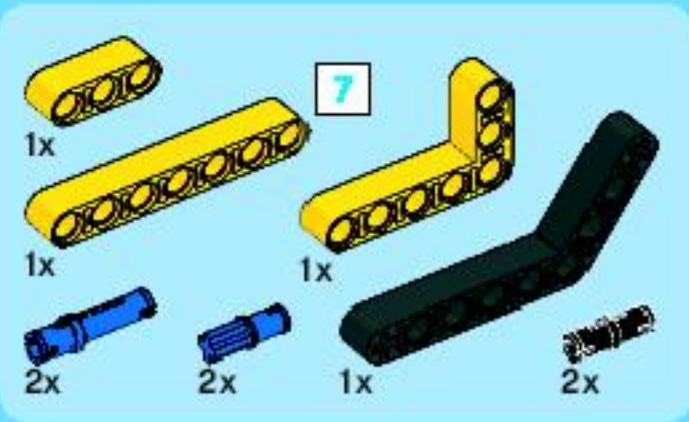
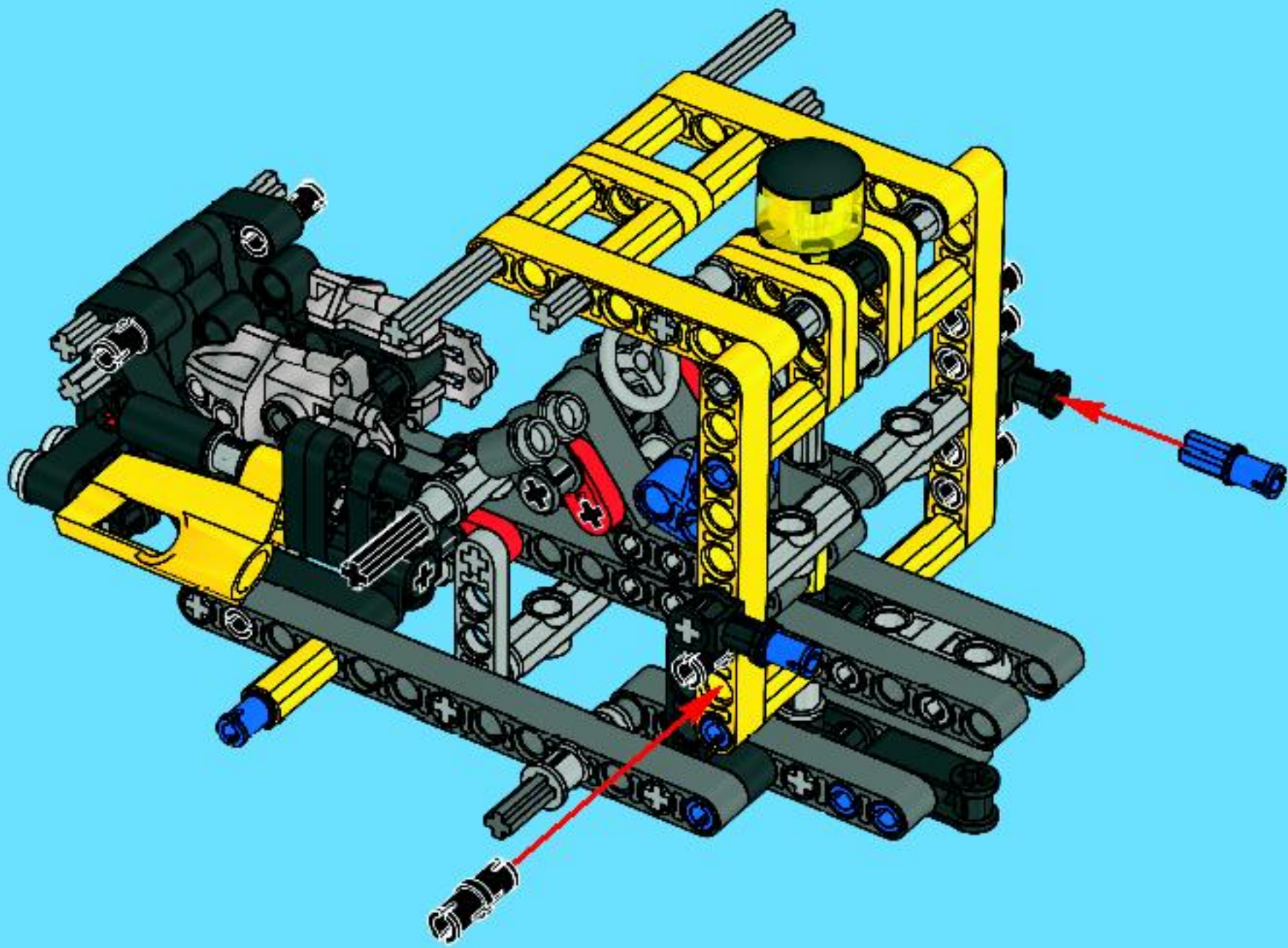

37

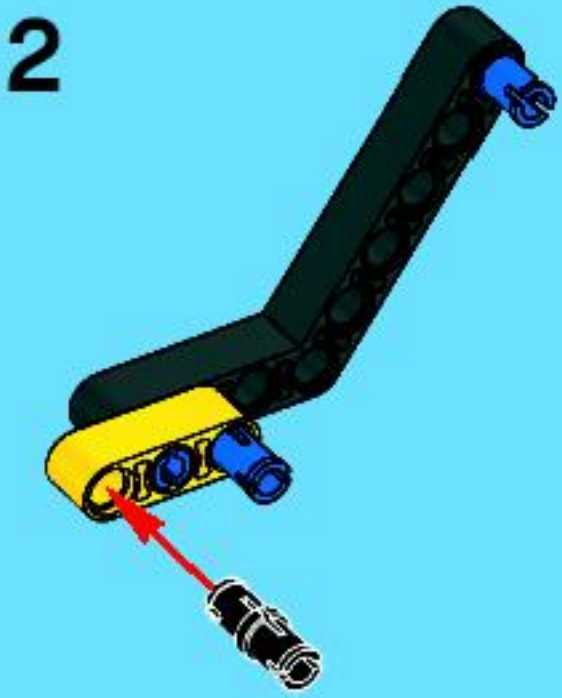
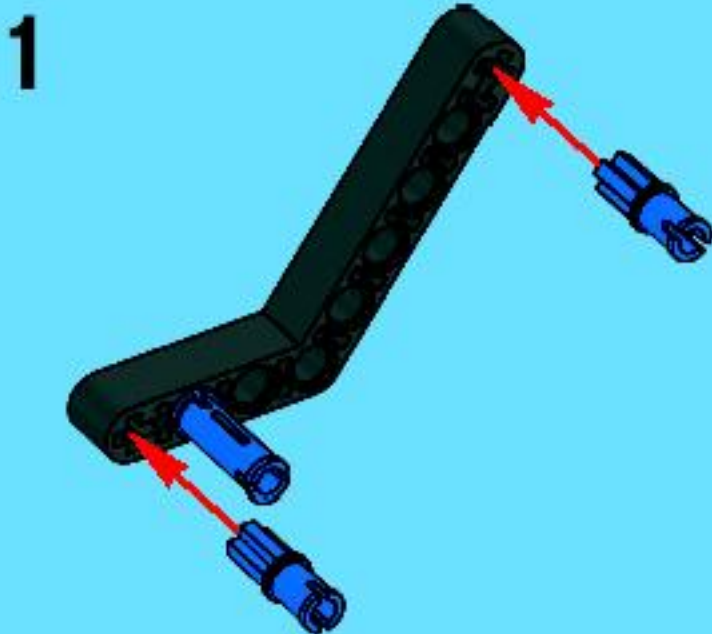

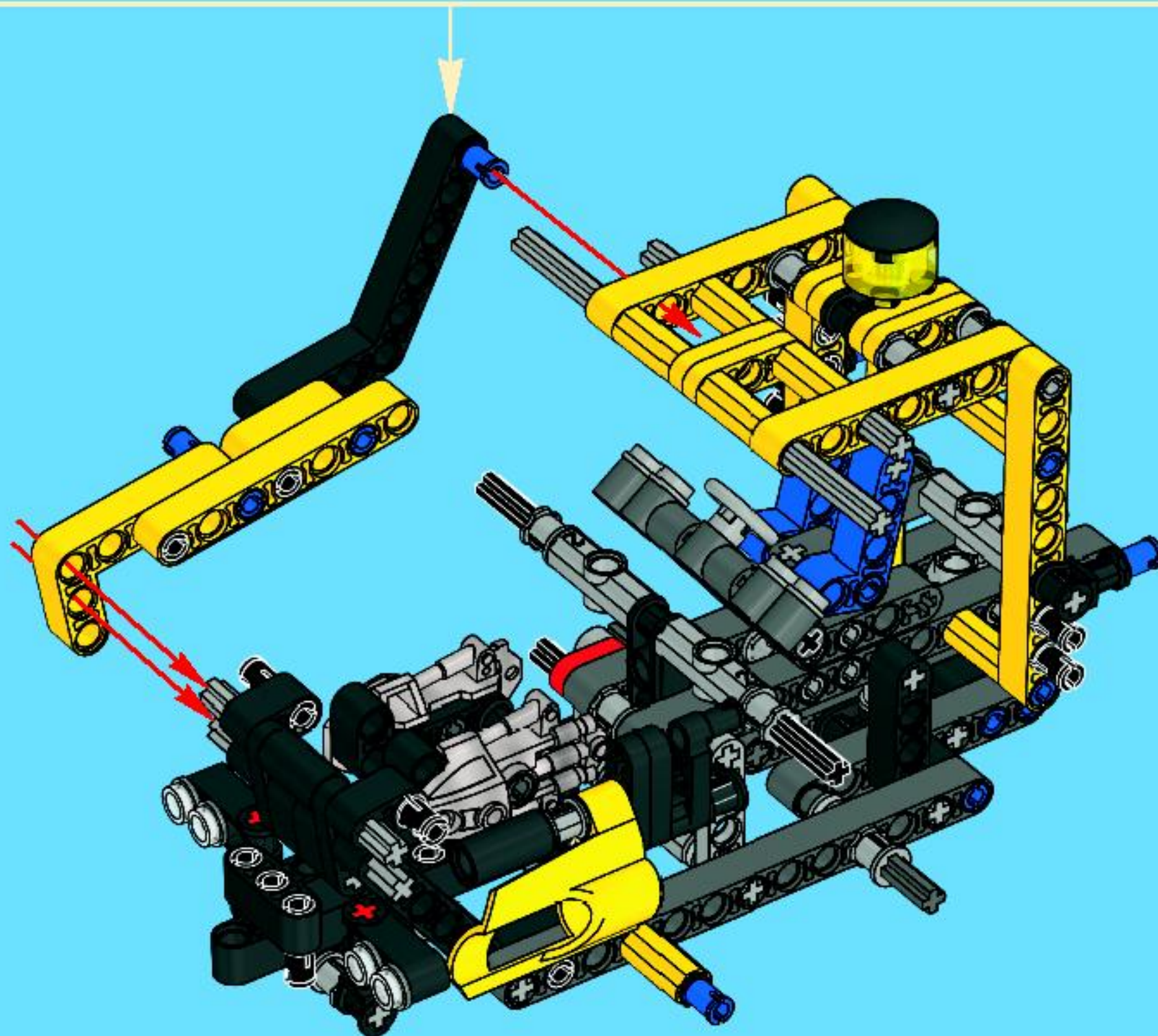
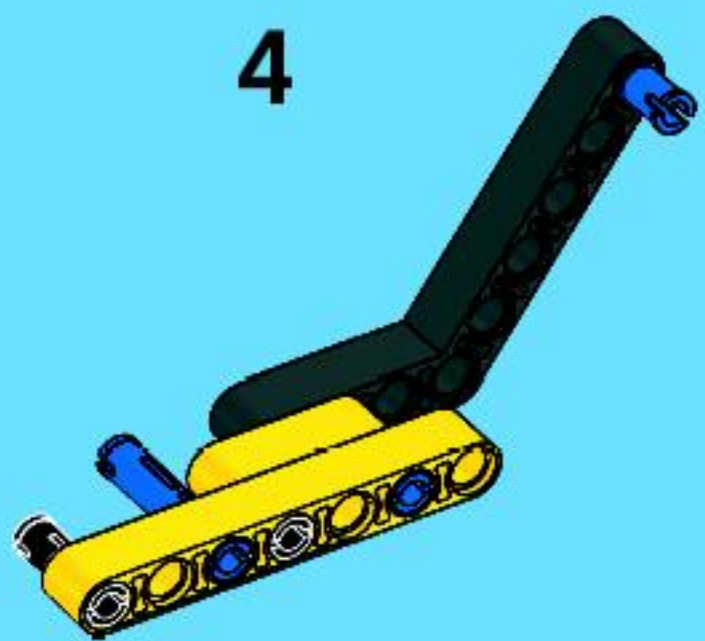
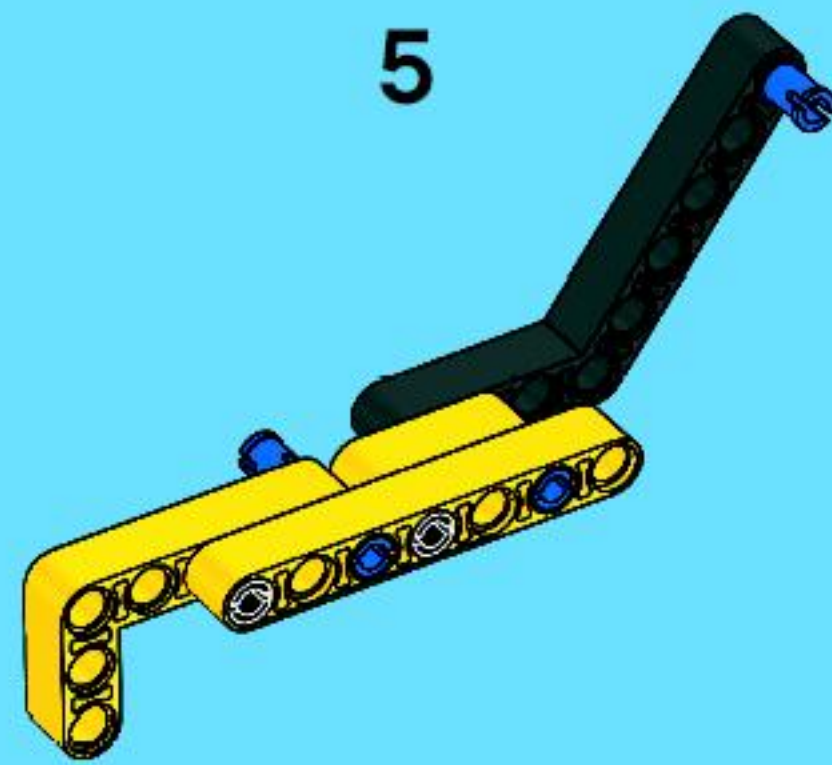
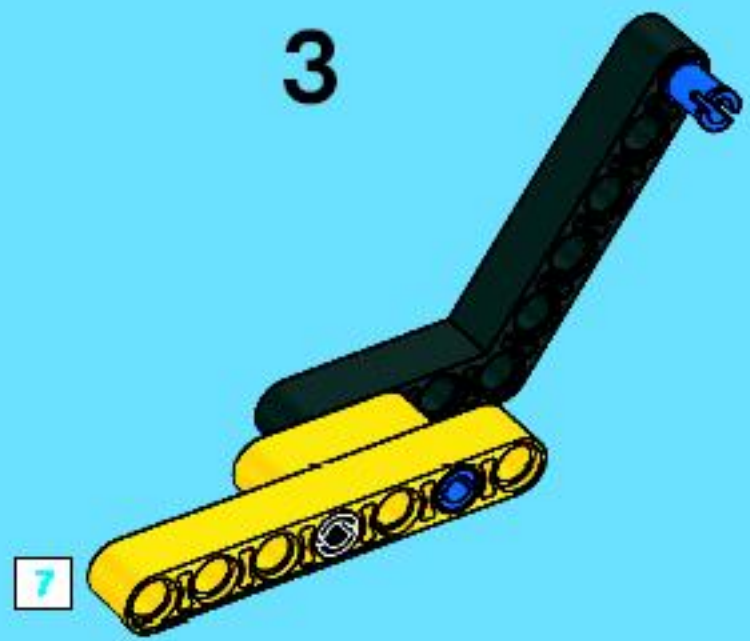

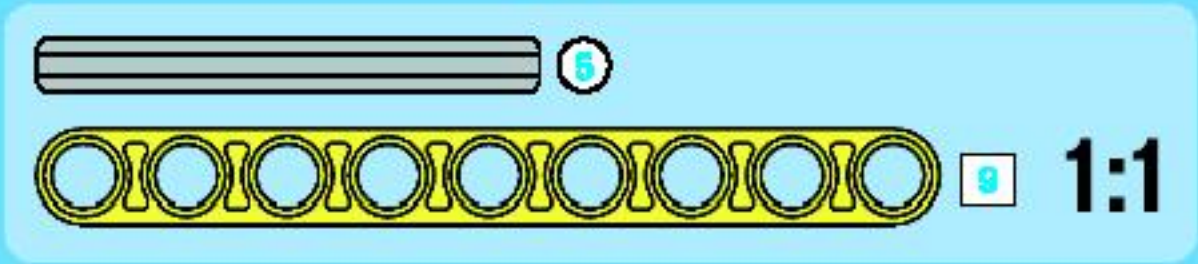
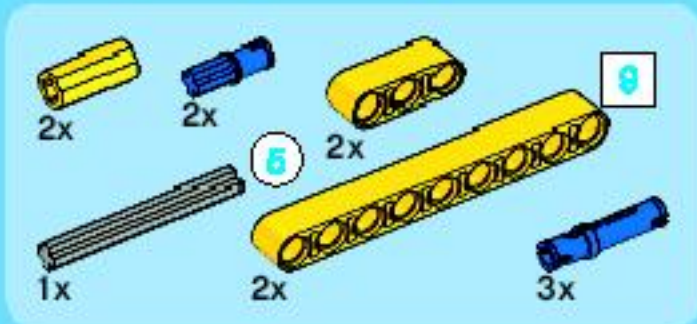

38

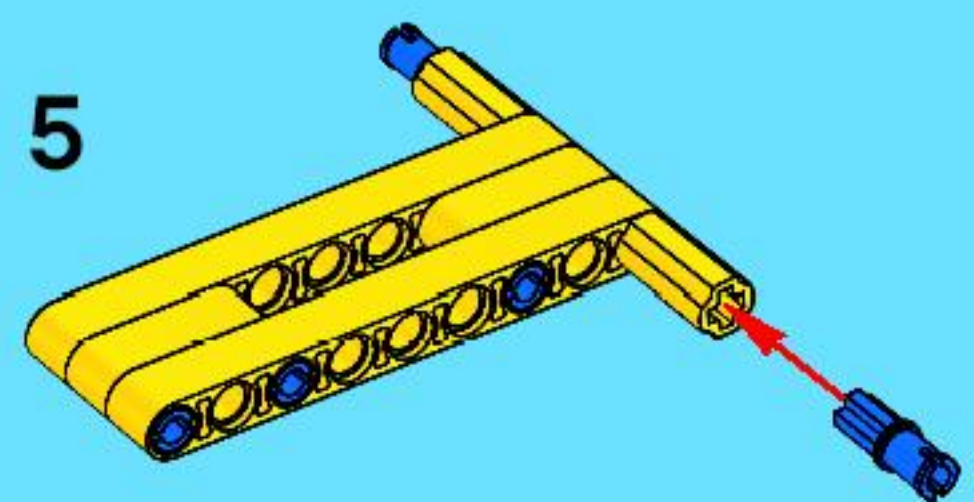
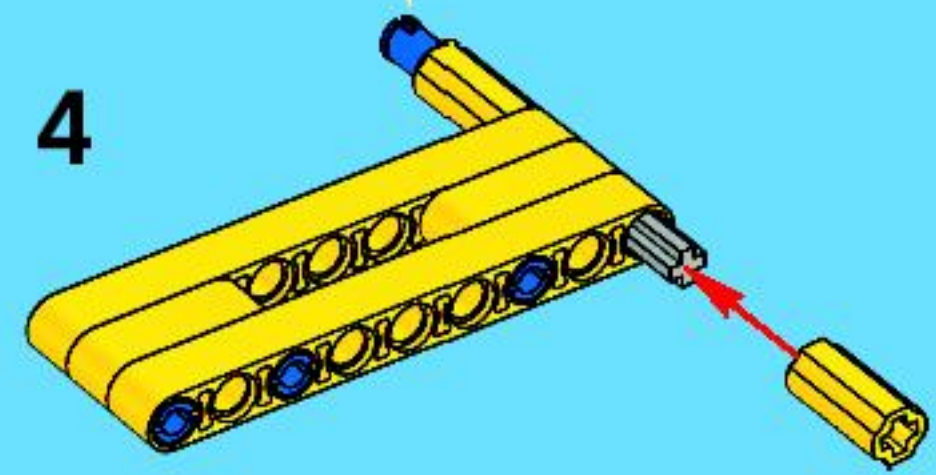
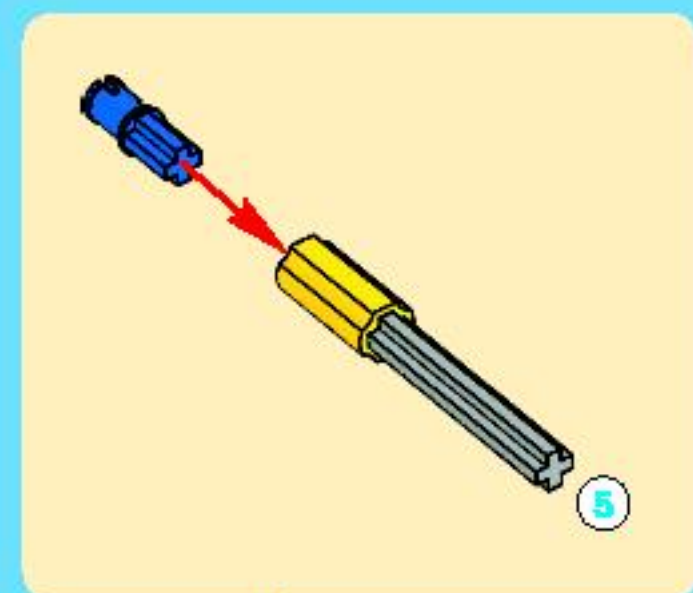
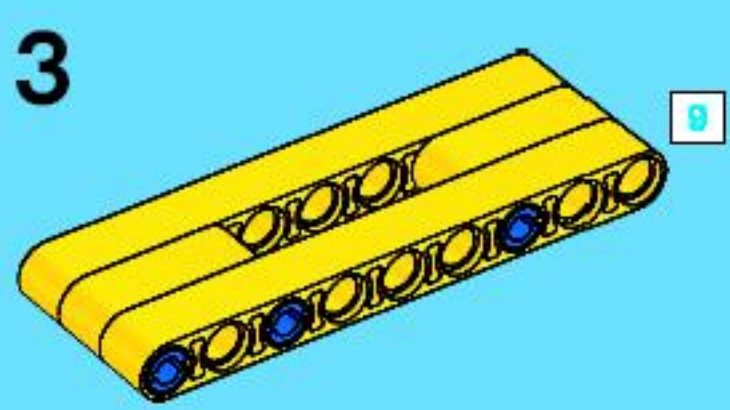
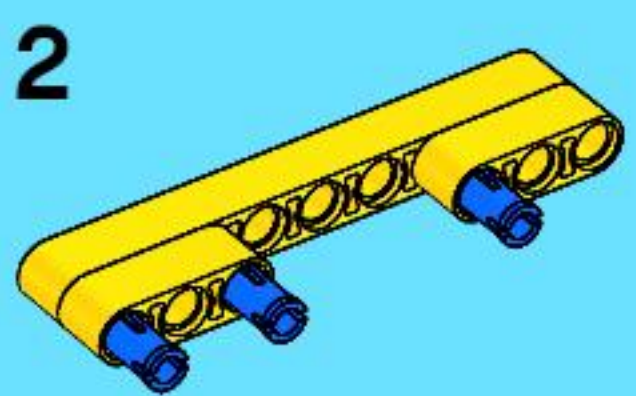
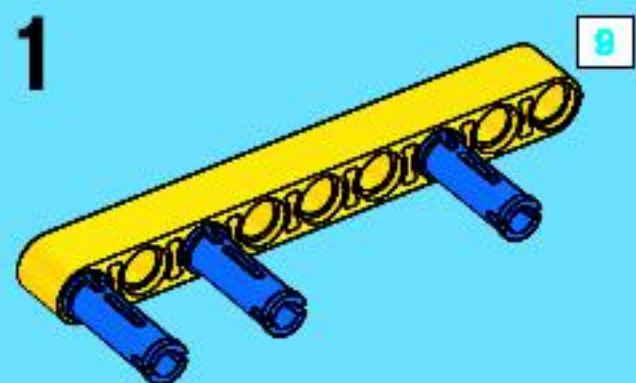

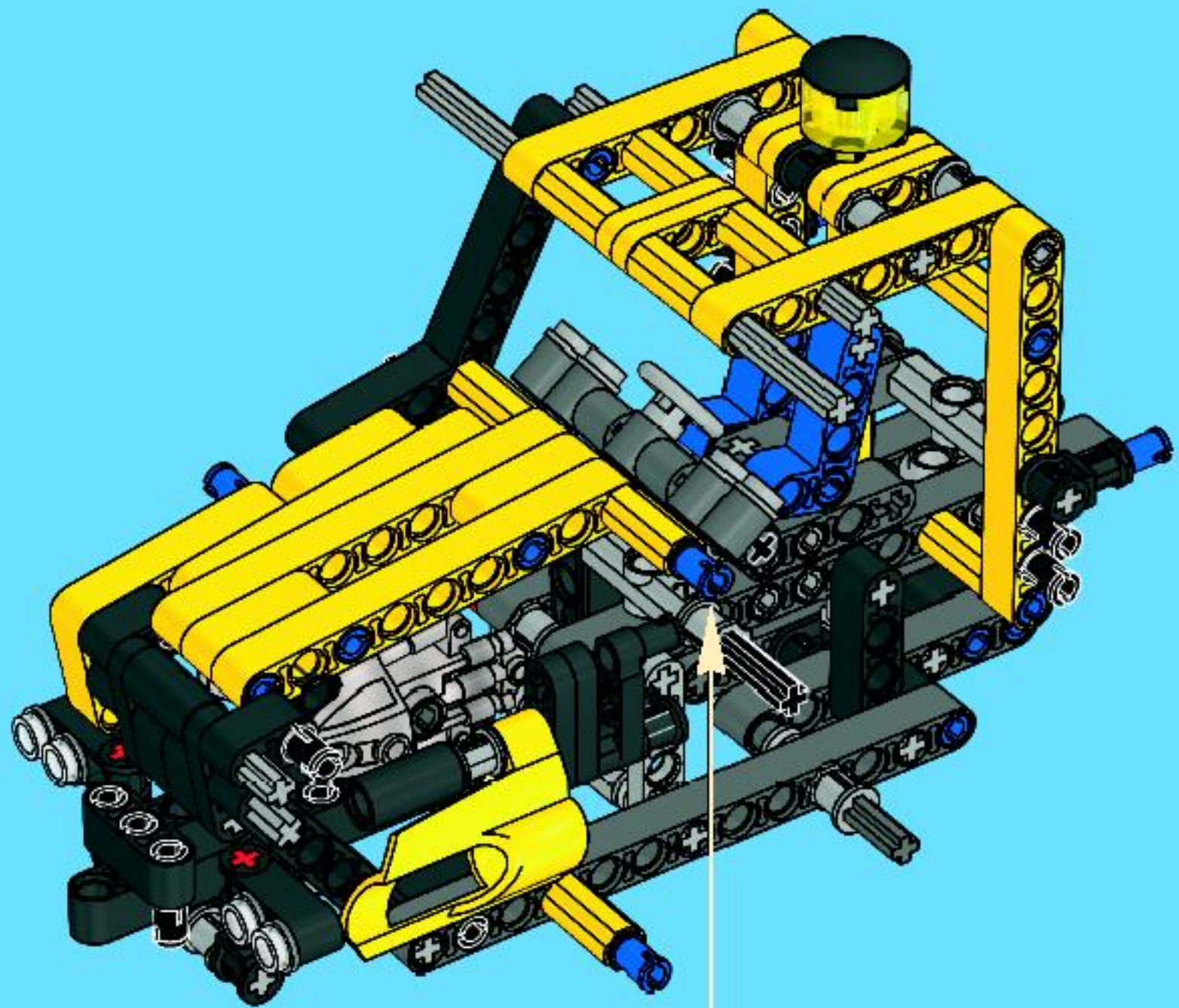

39

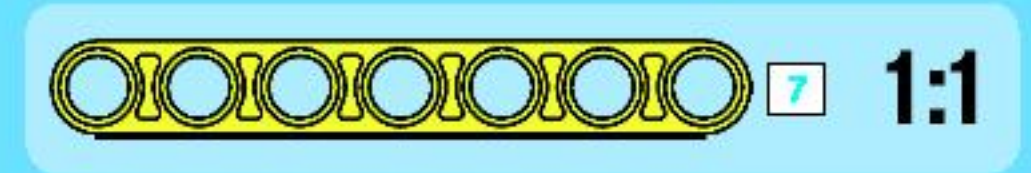
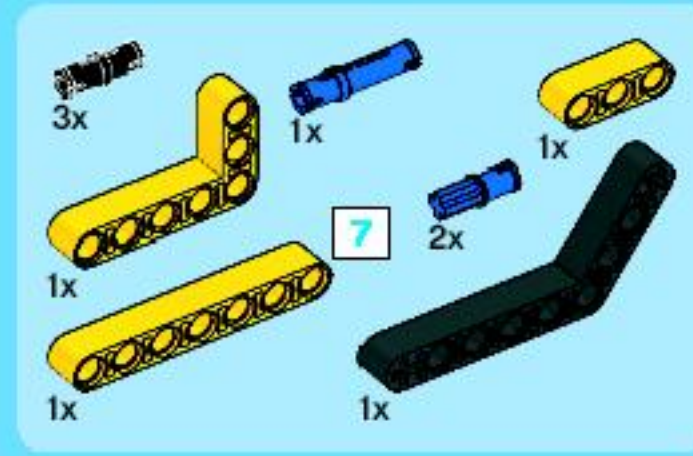

1

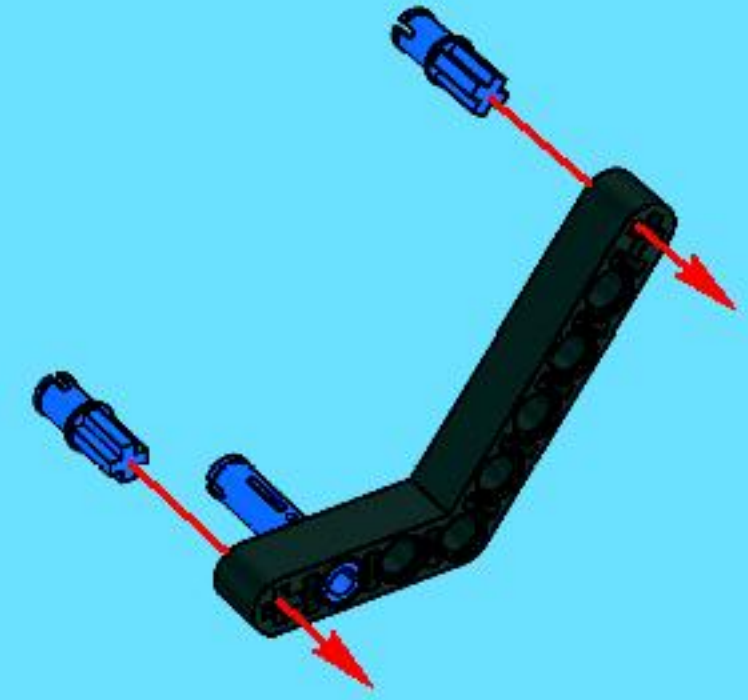

2

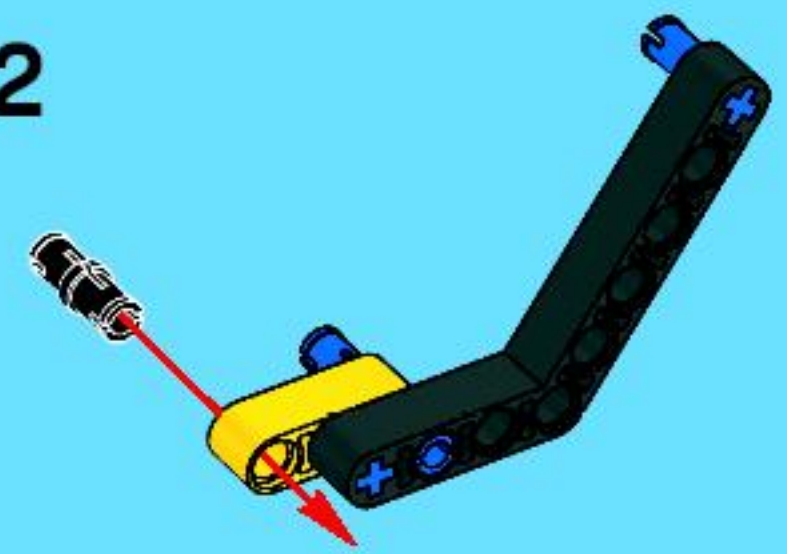

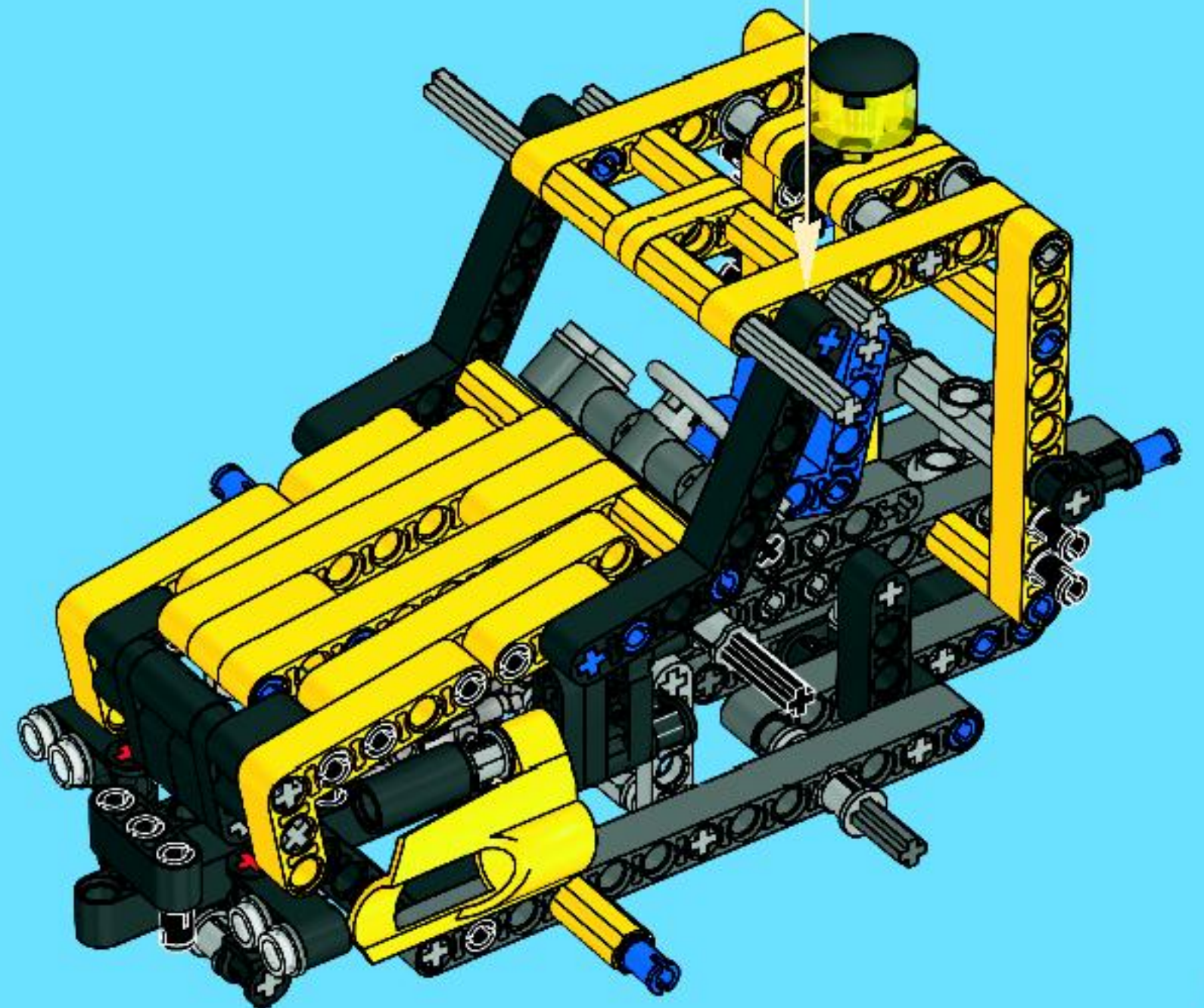
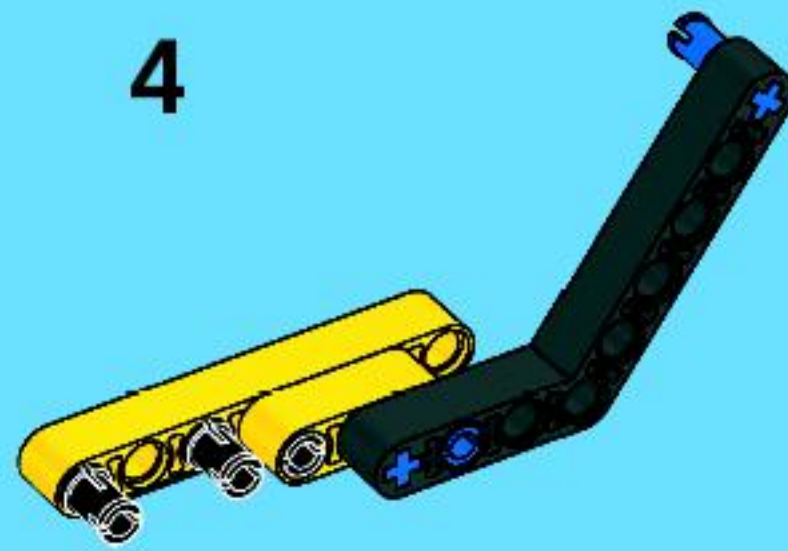
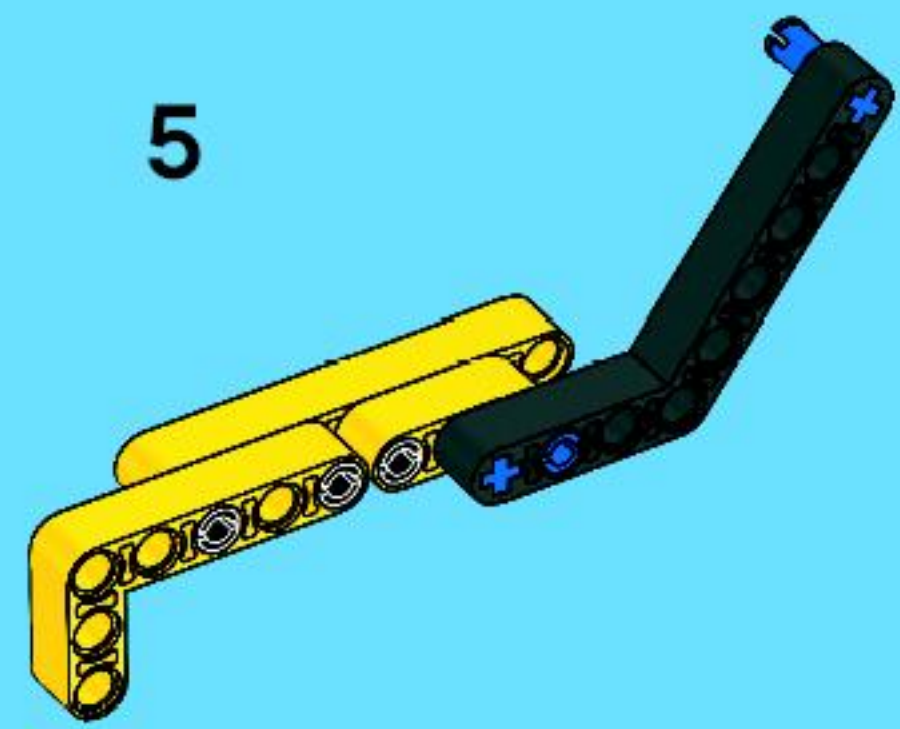
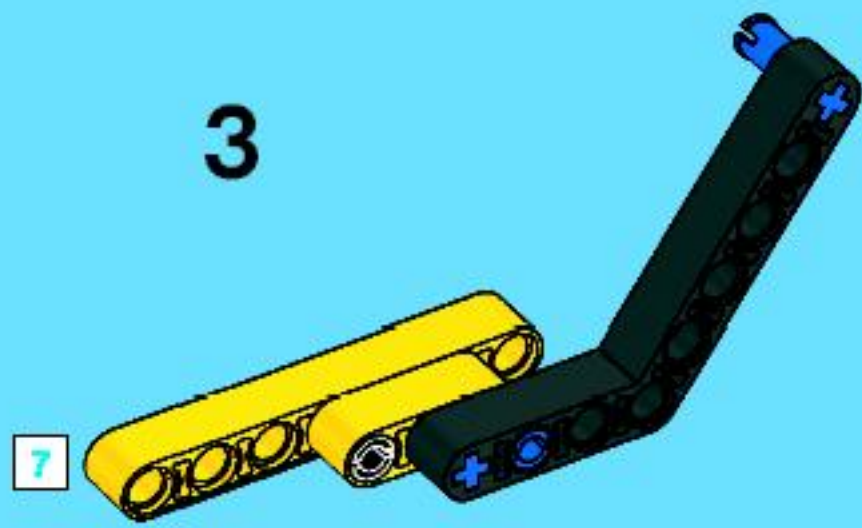

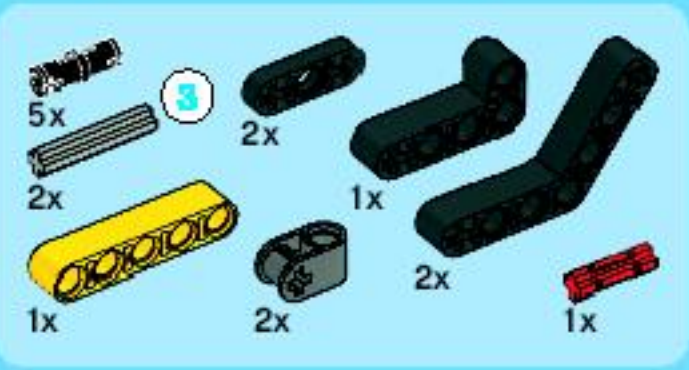

40

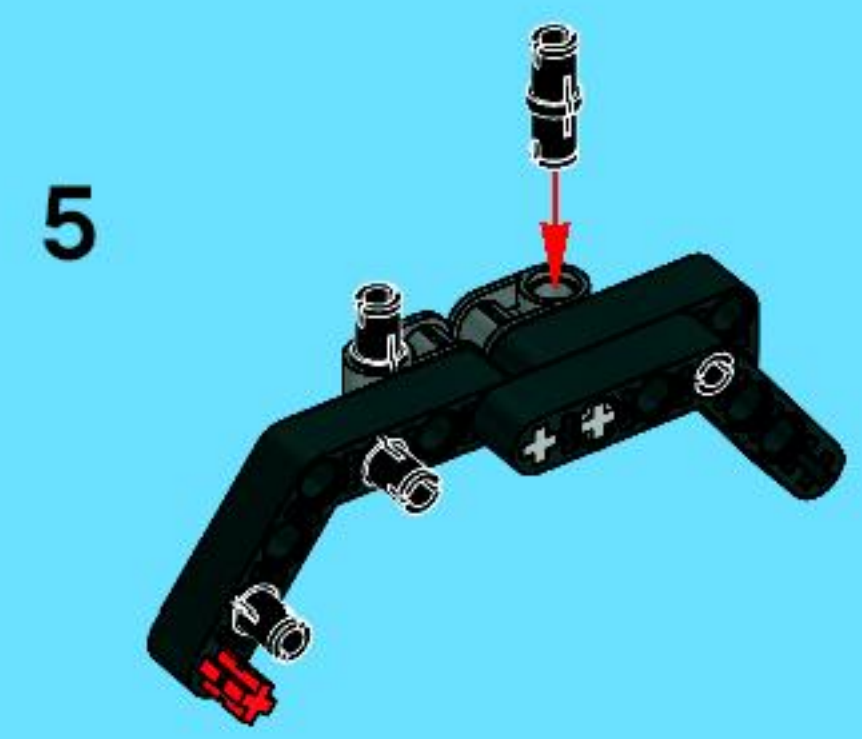
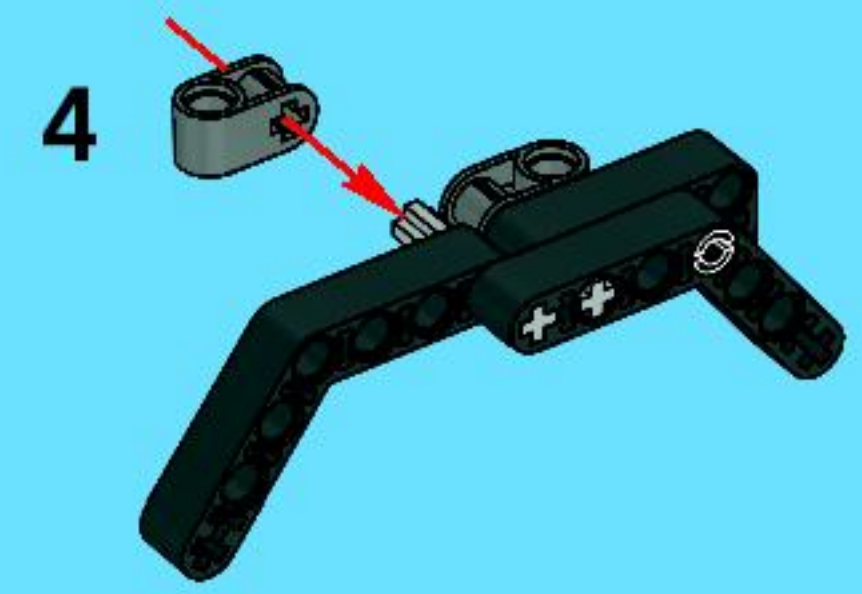
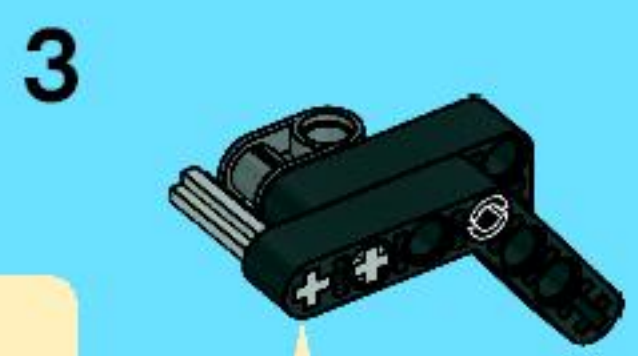
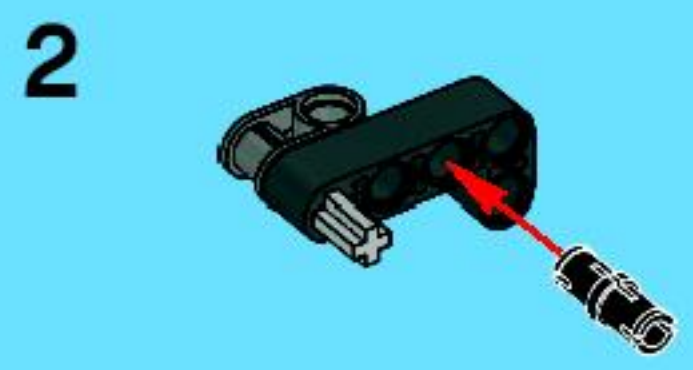

6

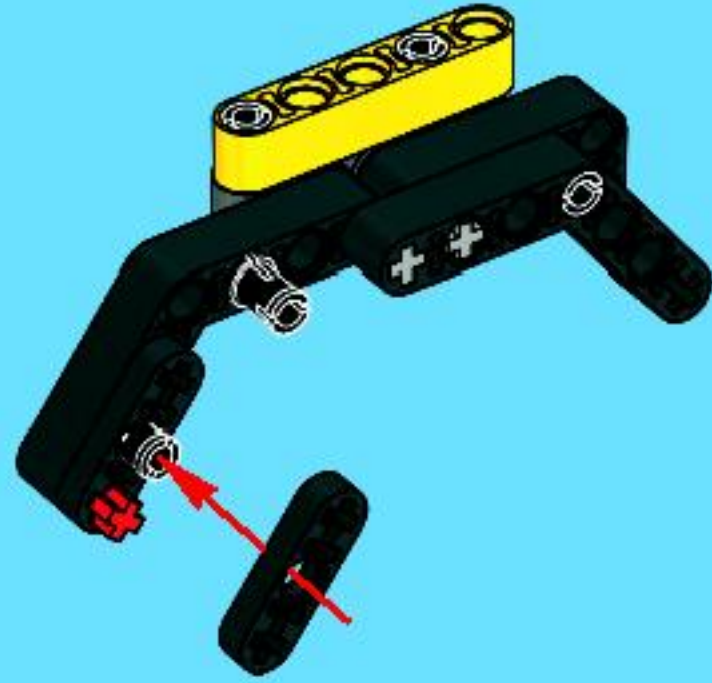

7

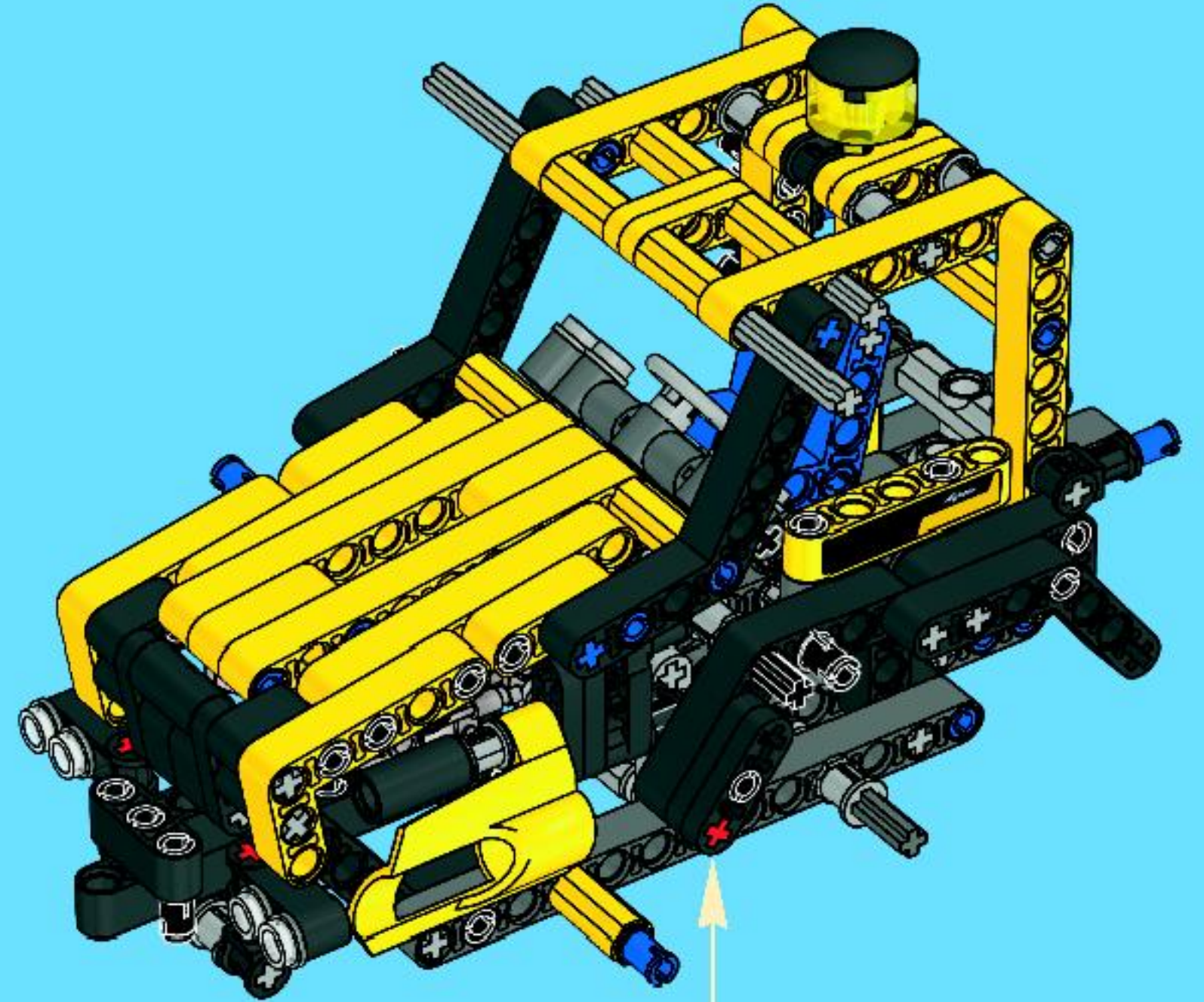
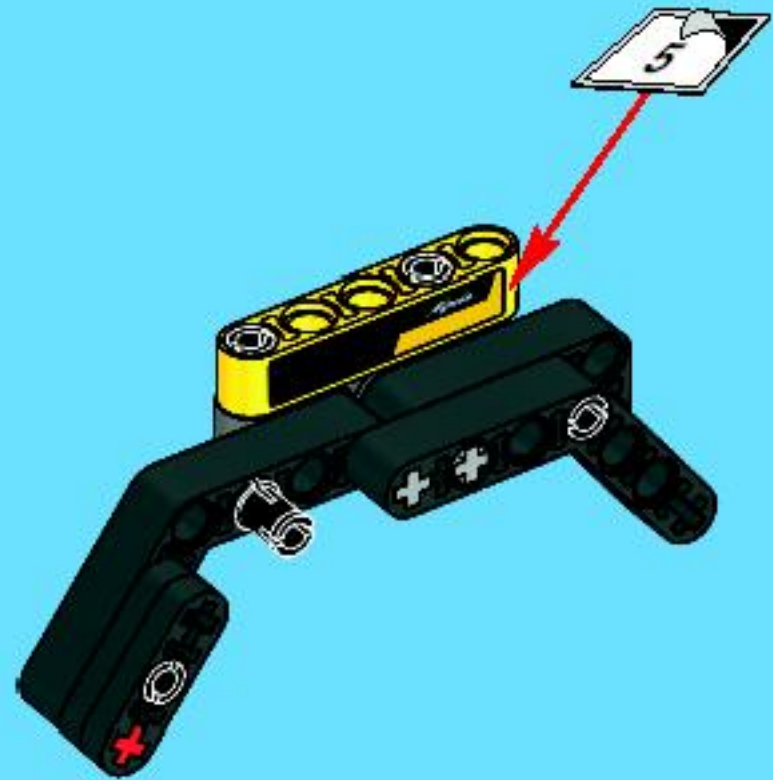



2x

41

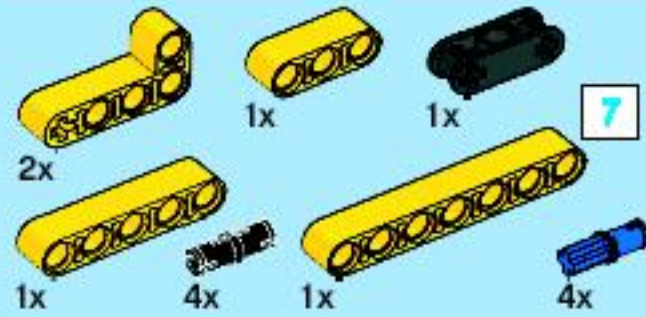
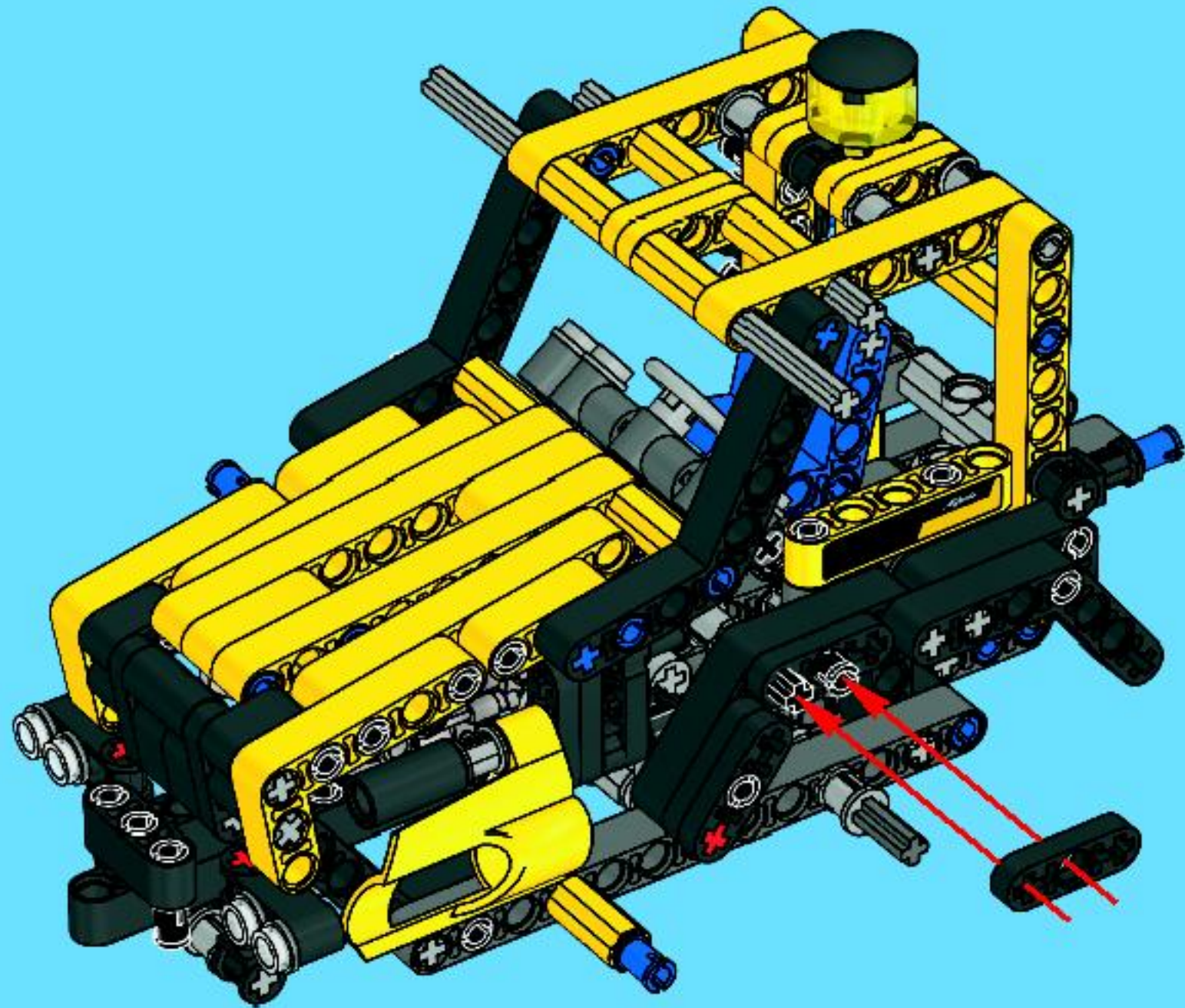

42

1

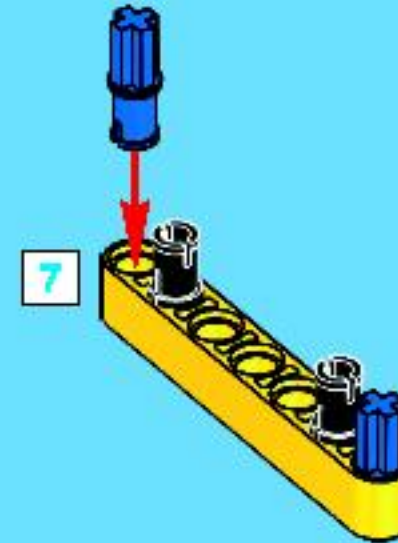

2

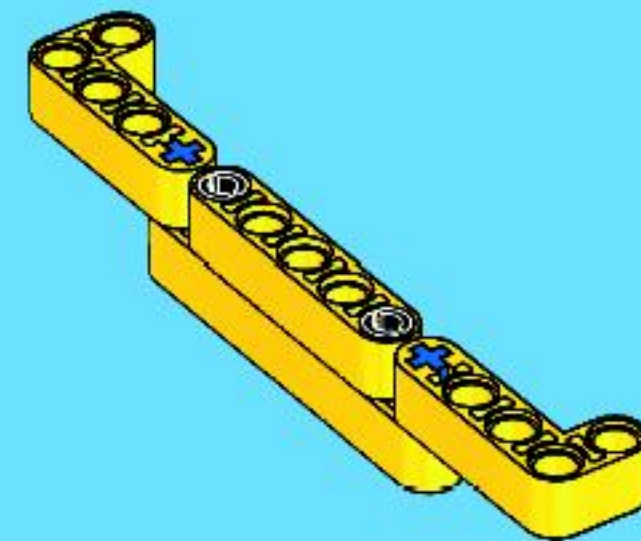

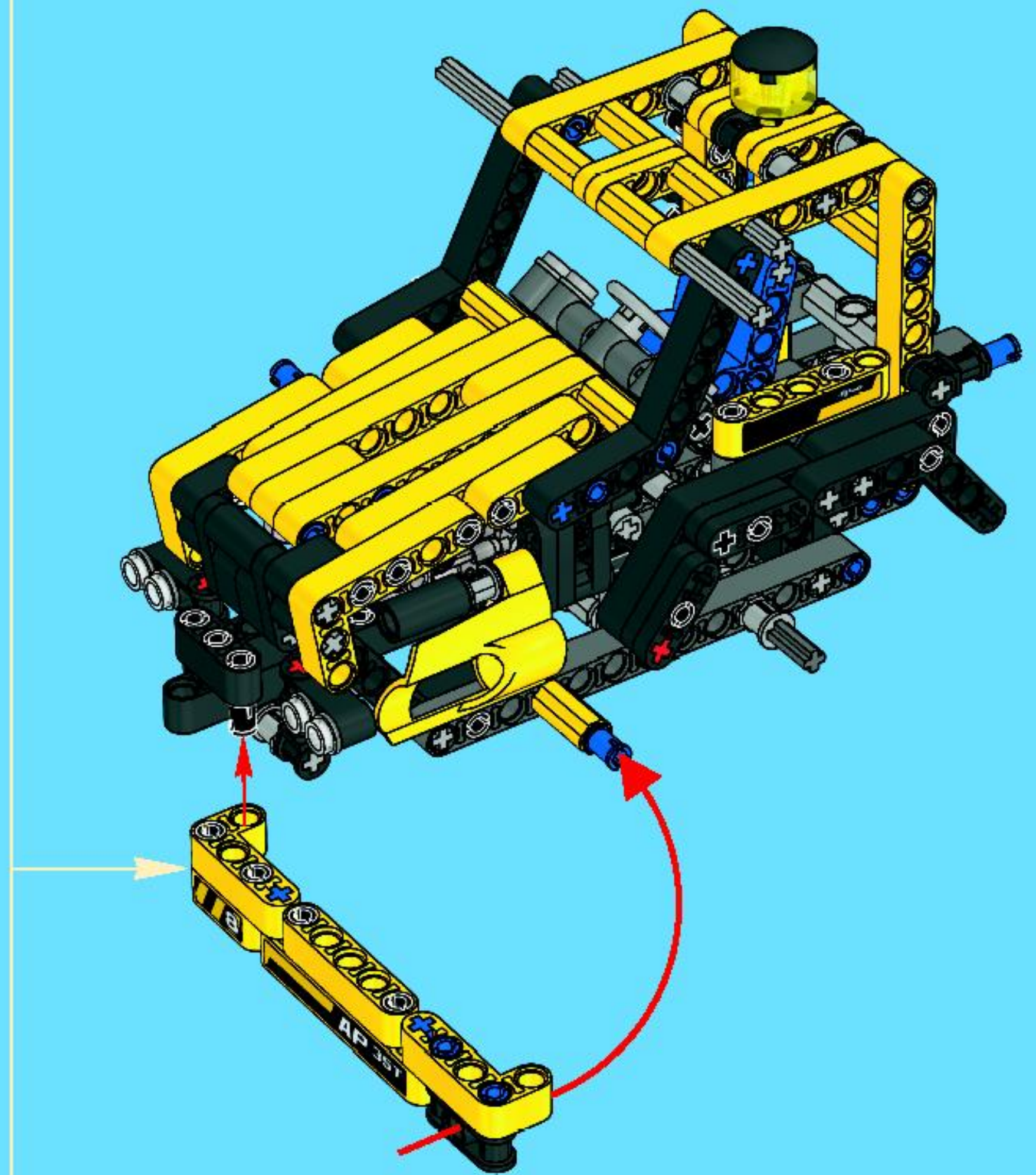
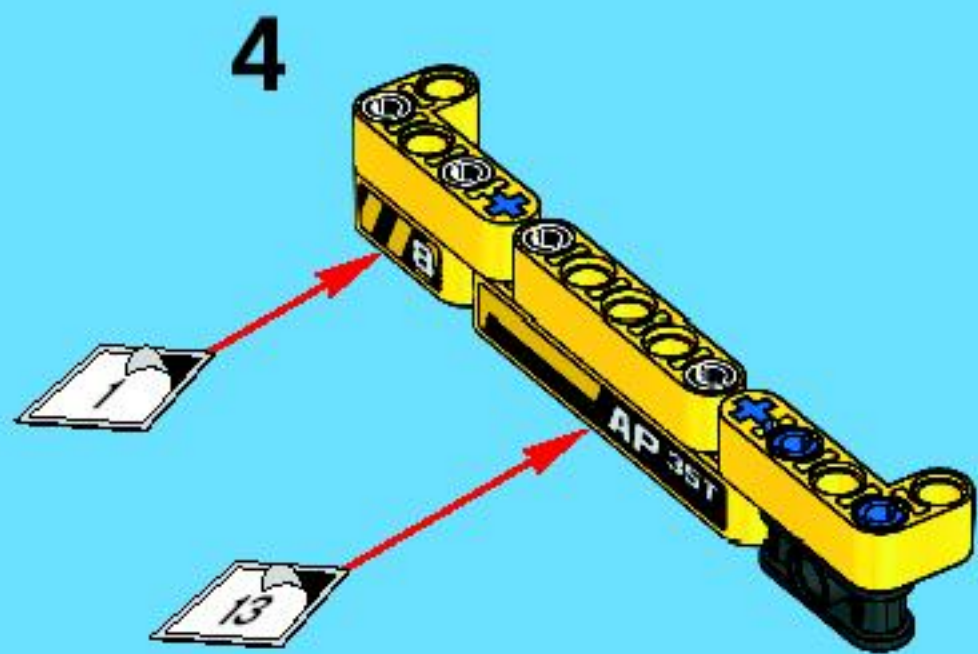
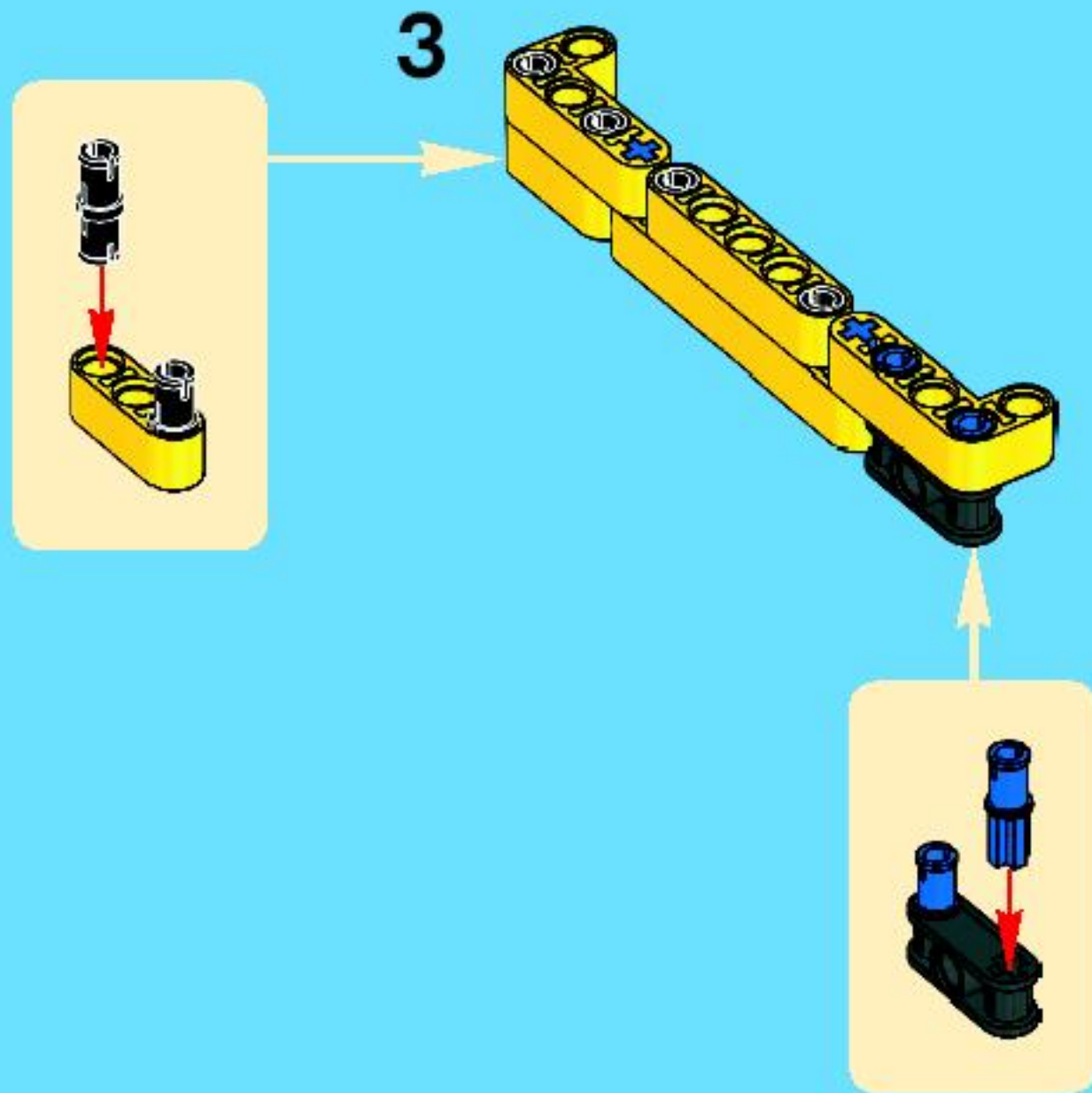

43

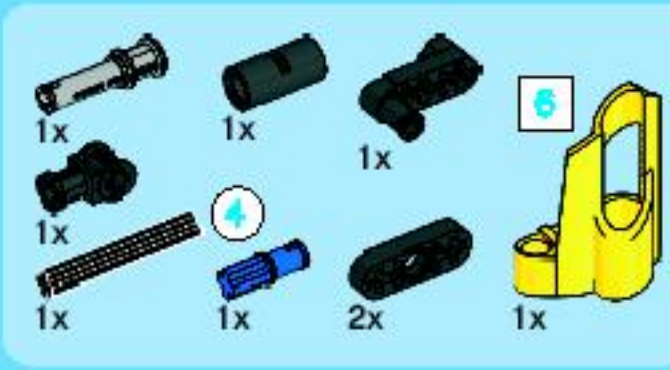
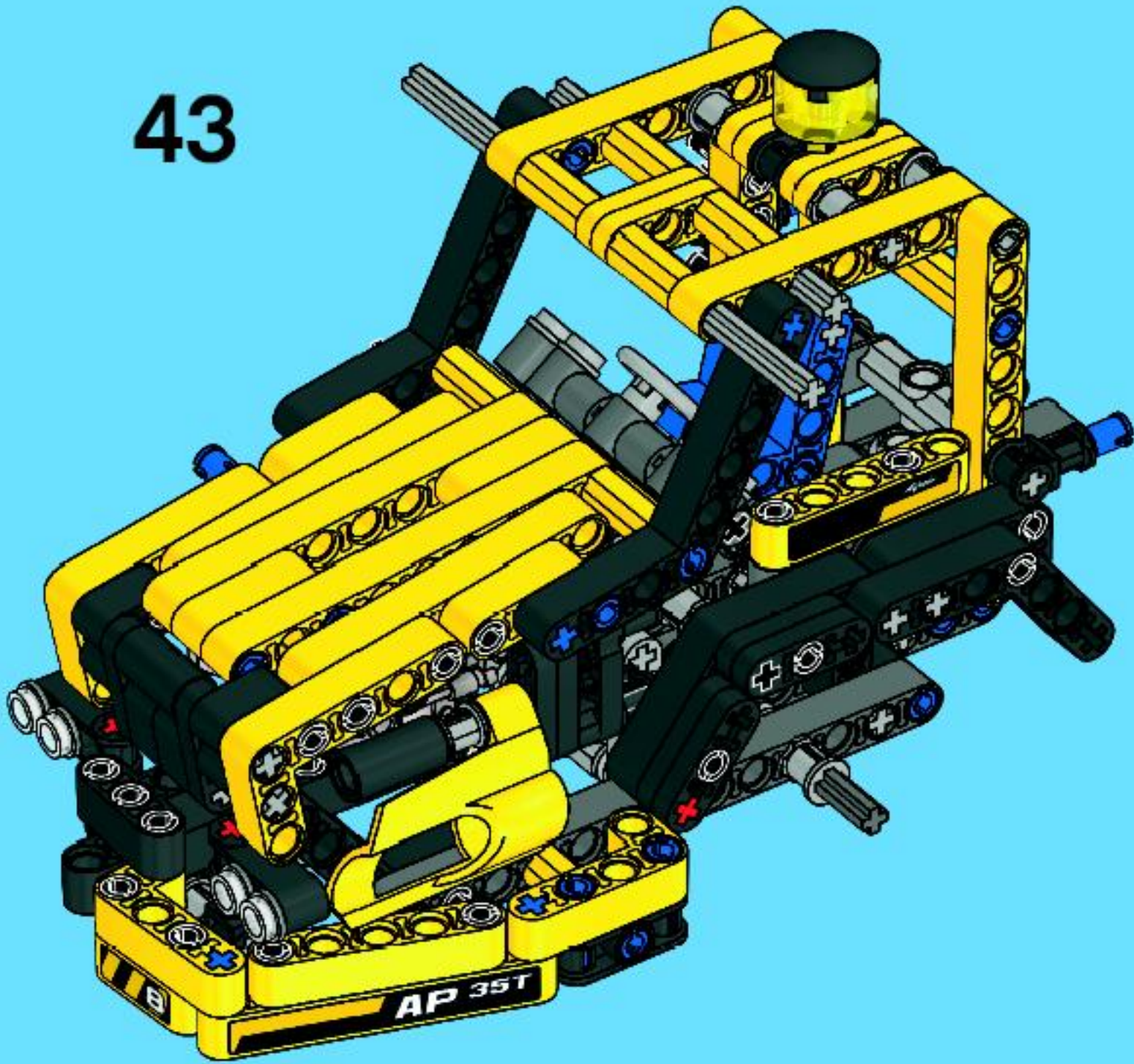

44

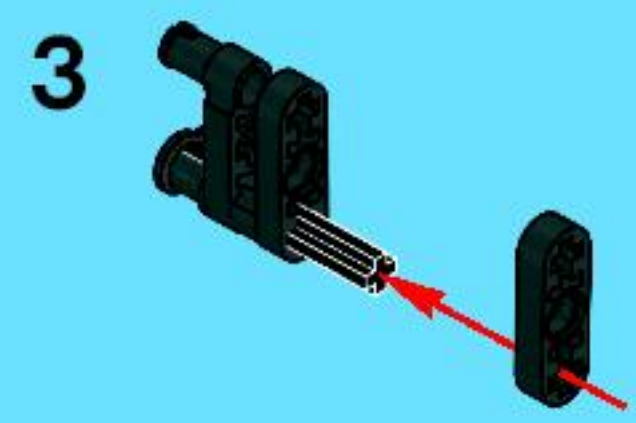

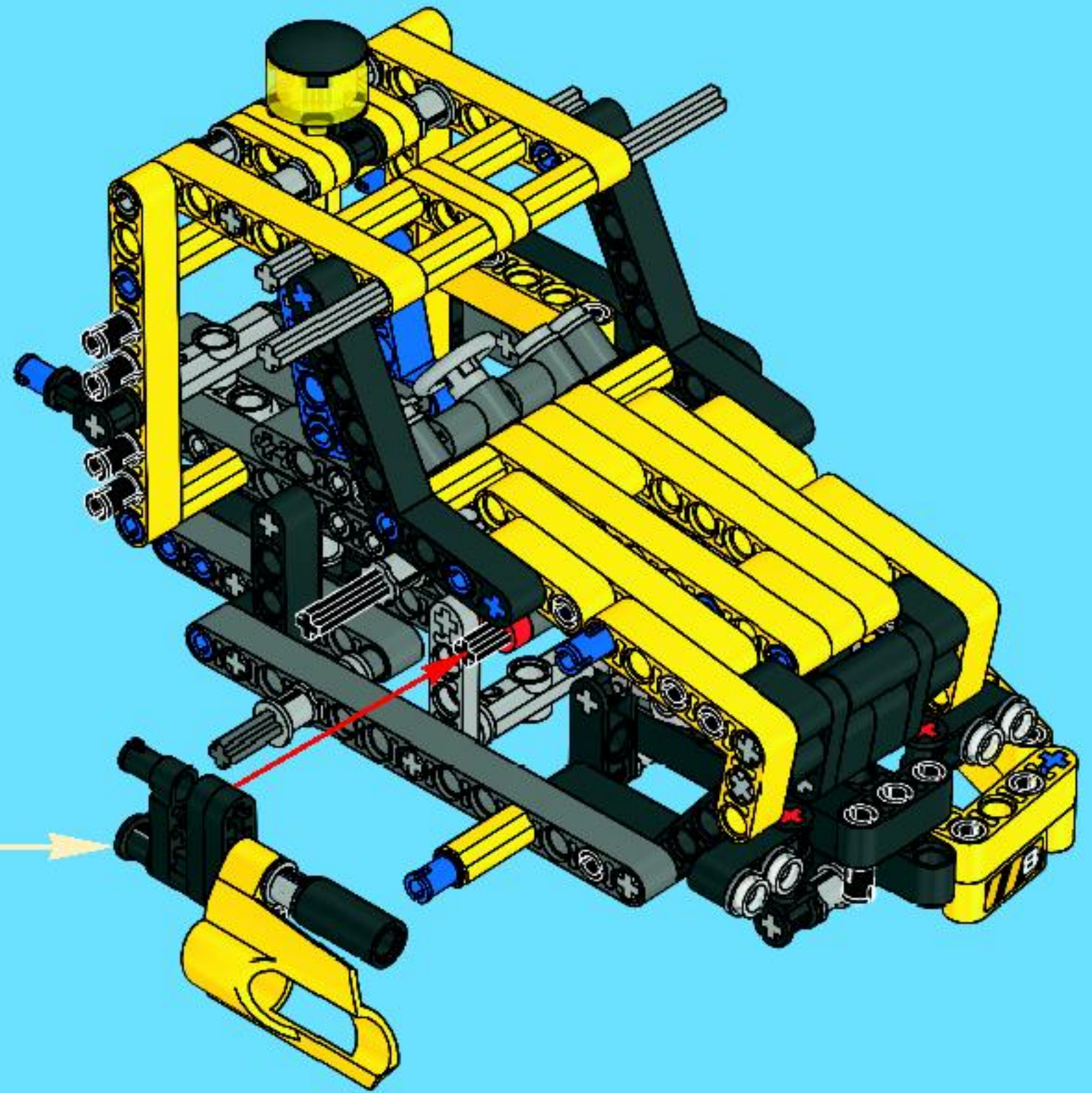
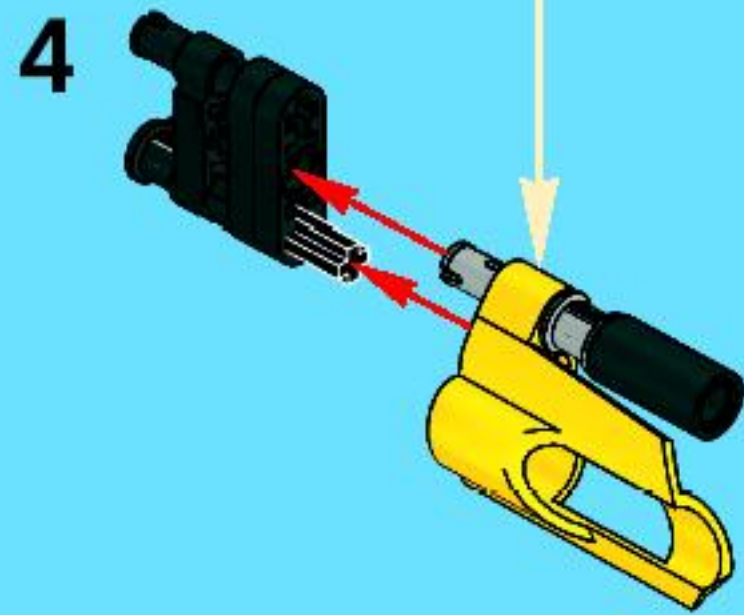
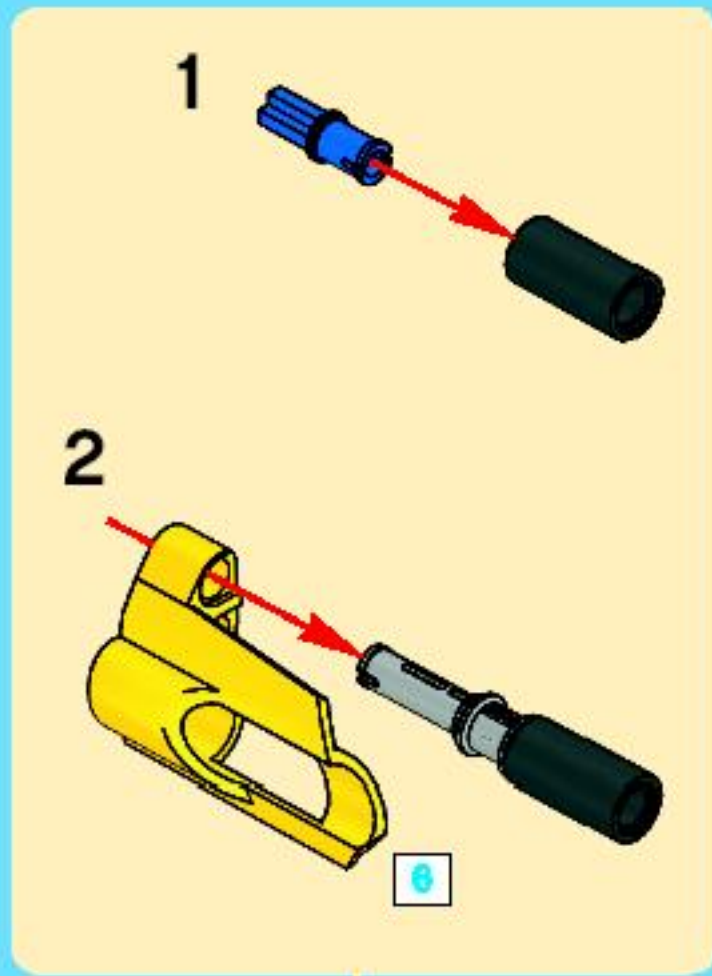

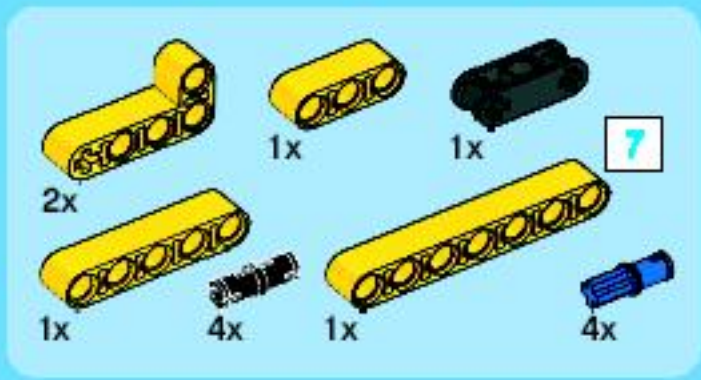

45

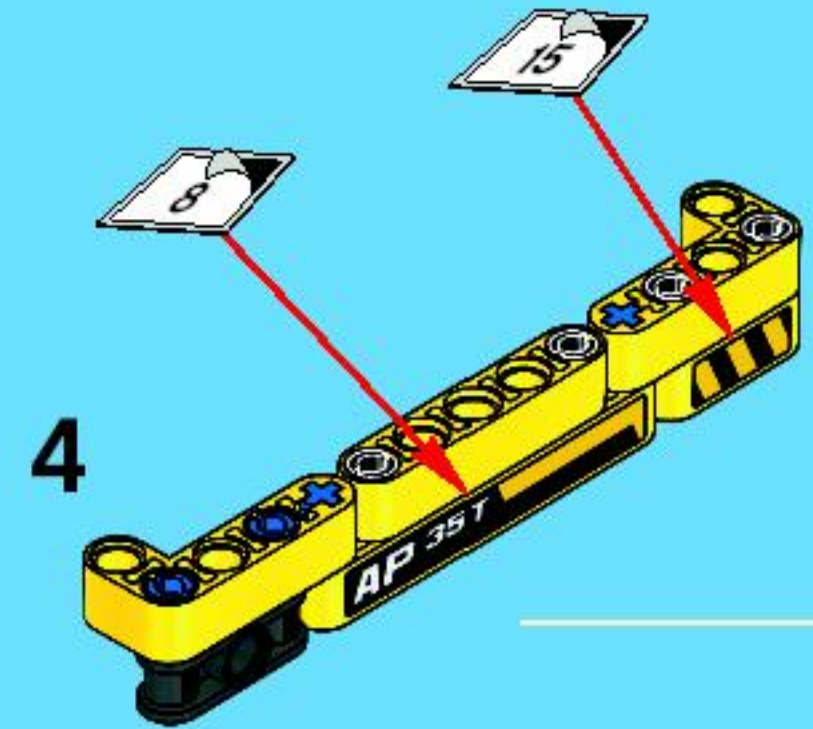
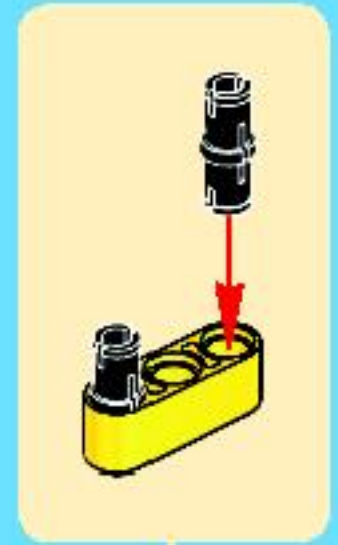
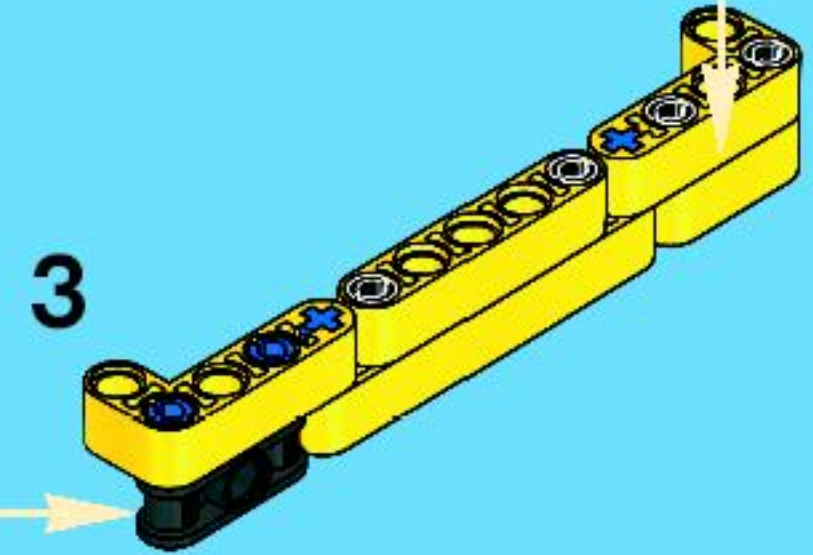
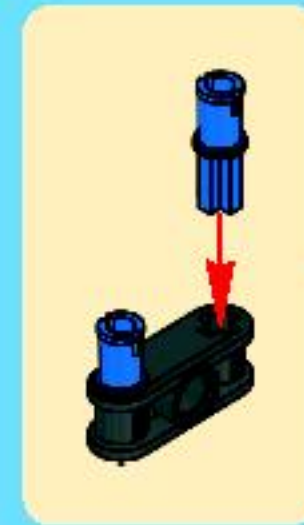
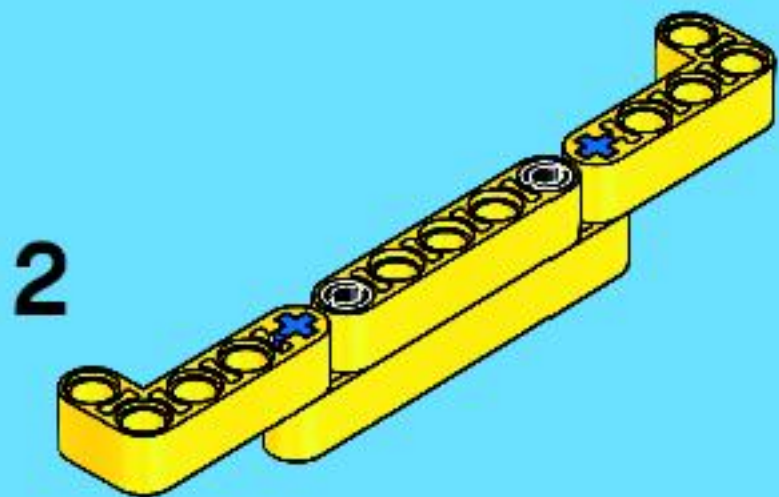
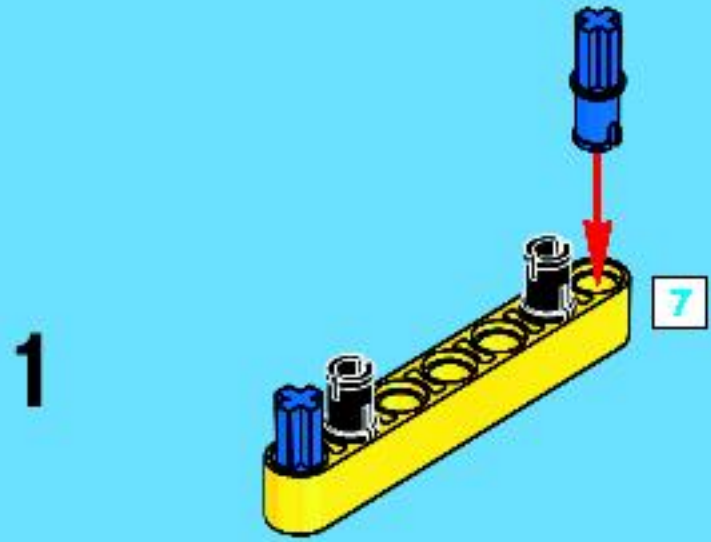

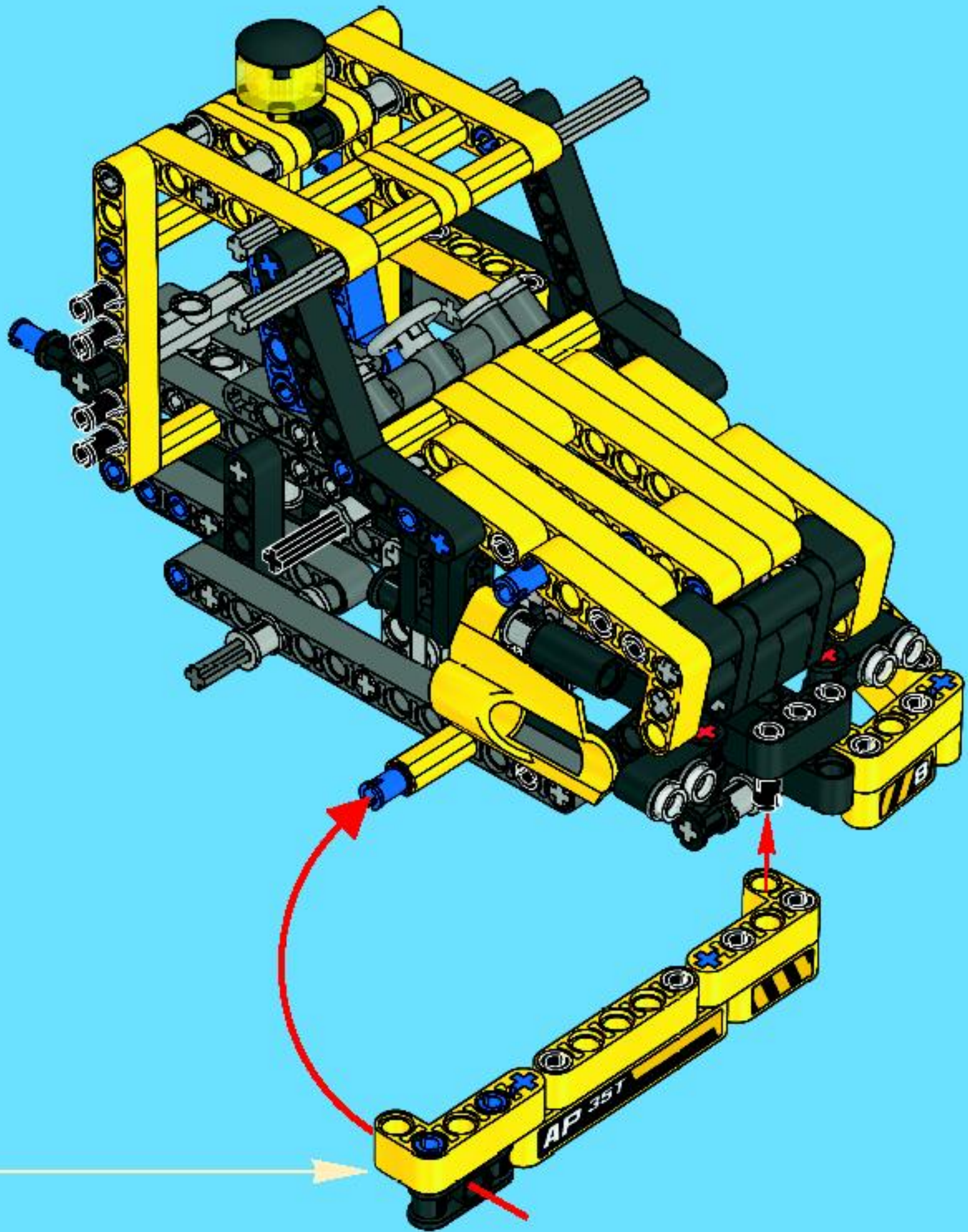

46

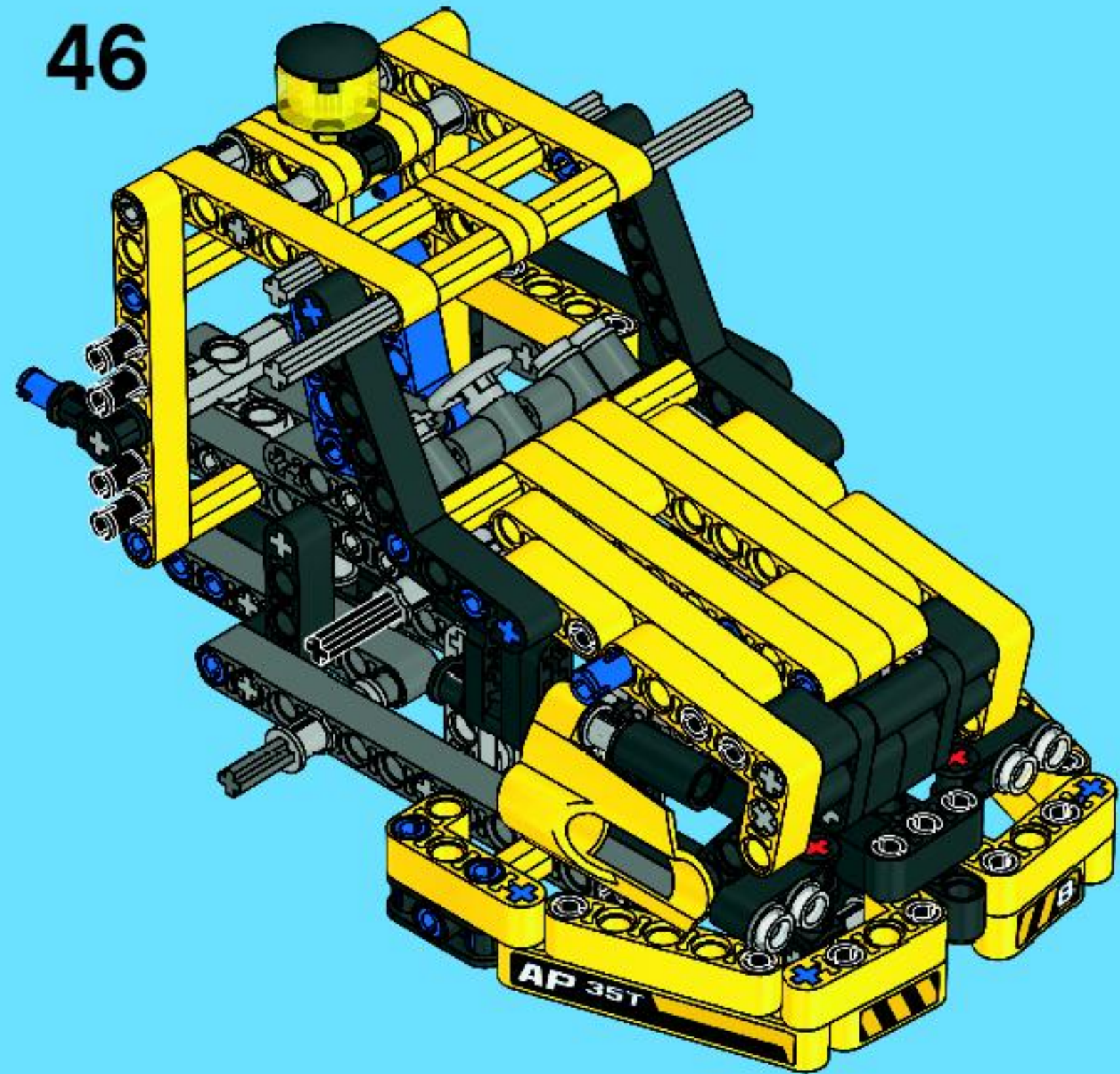

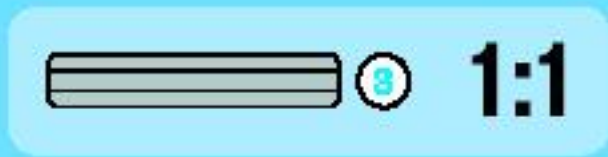
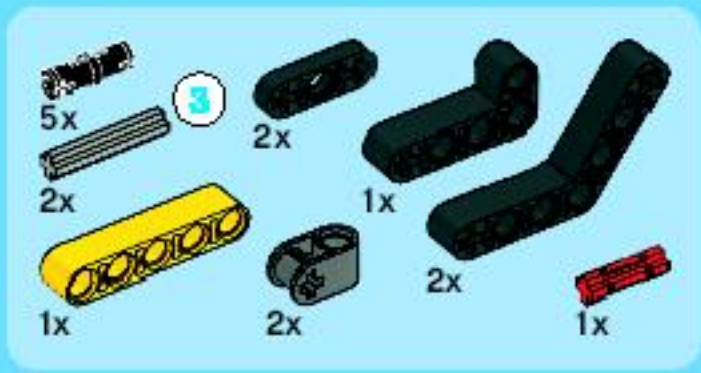

47

1



2

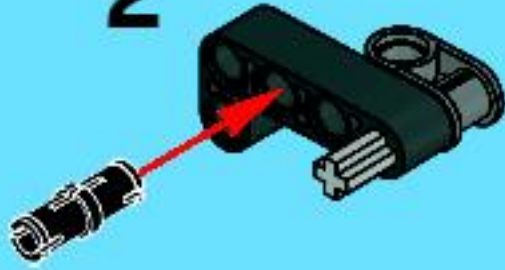

3

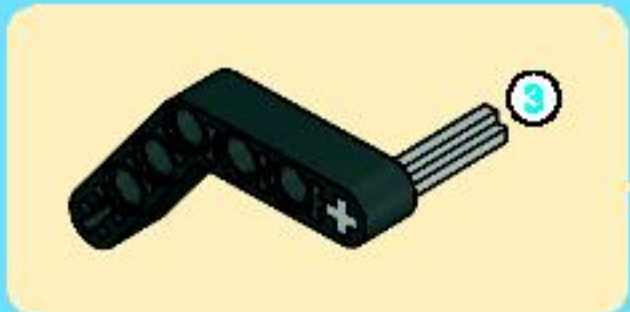

4

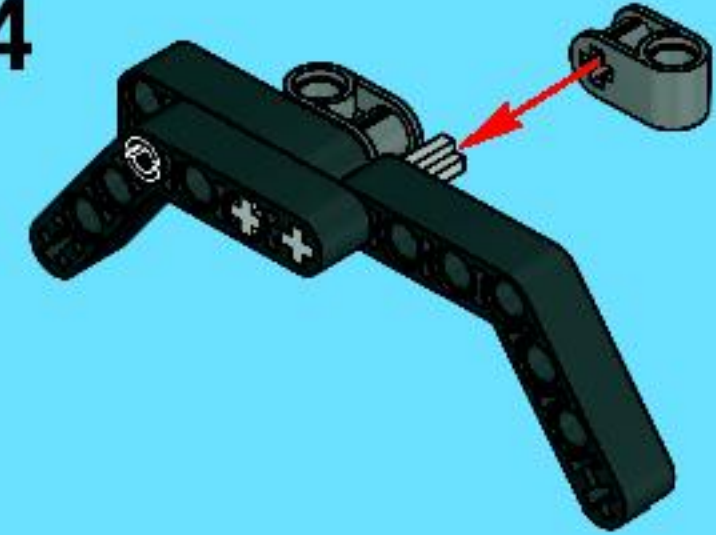

5

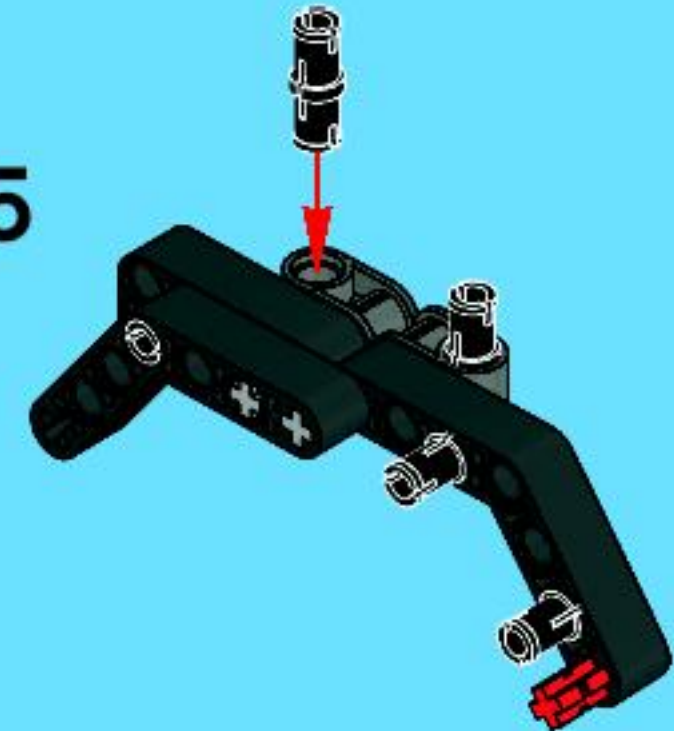

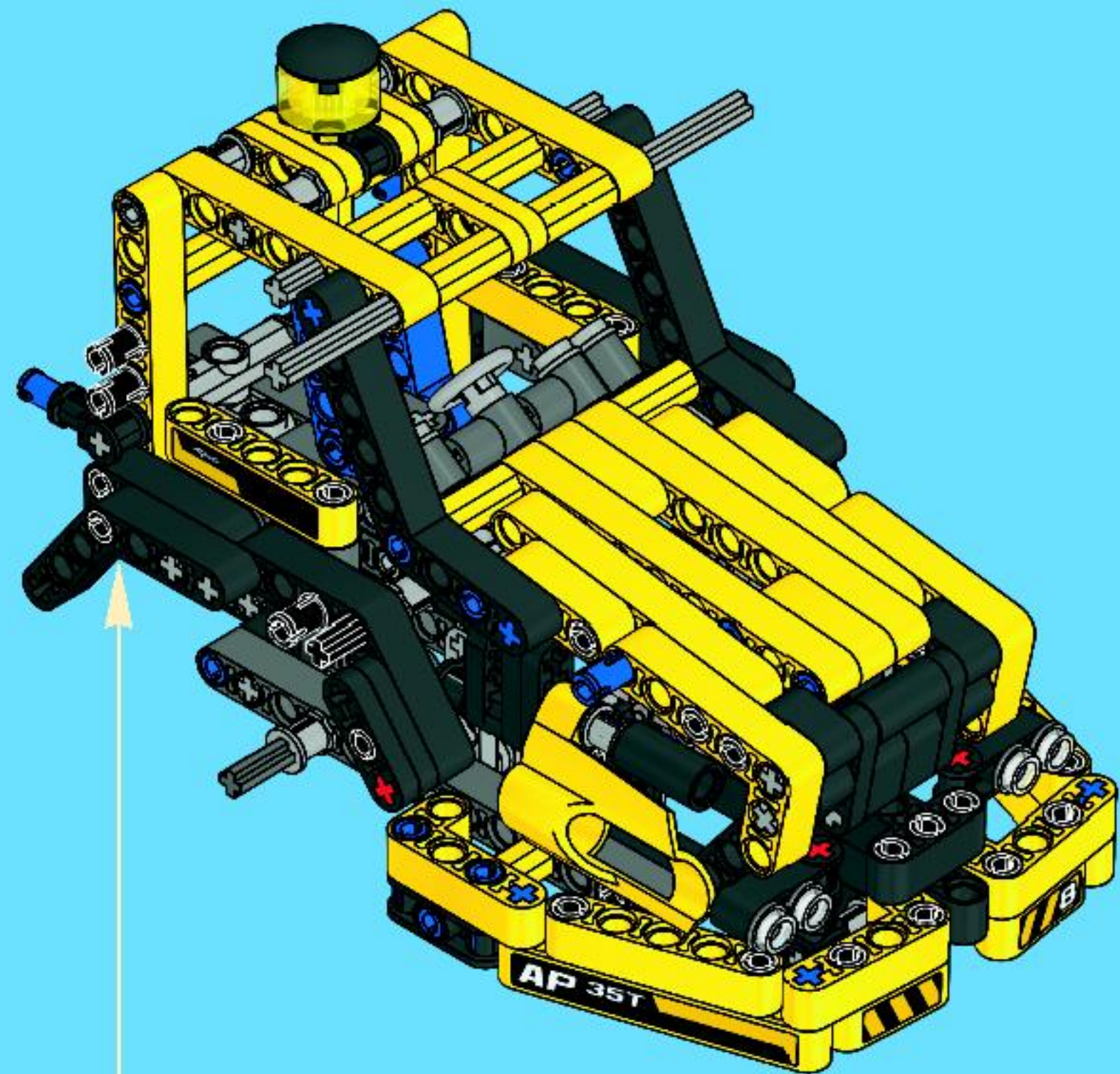
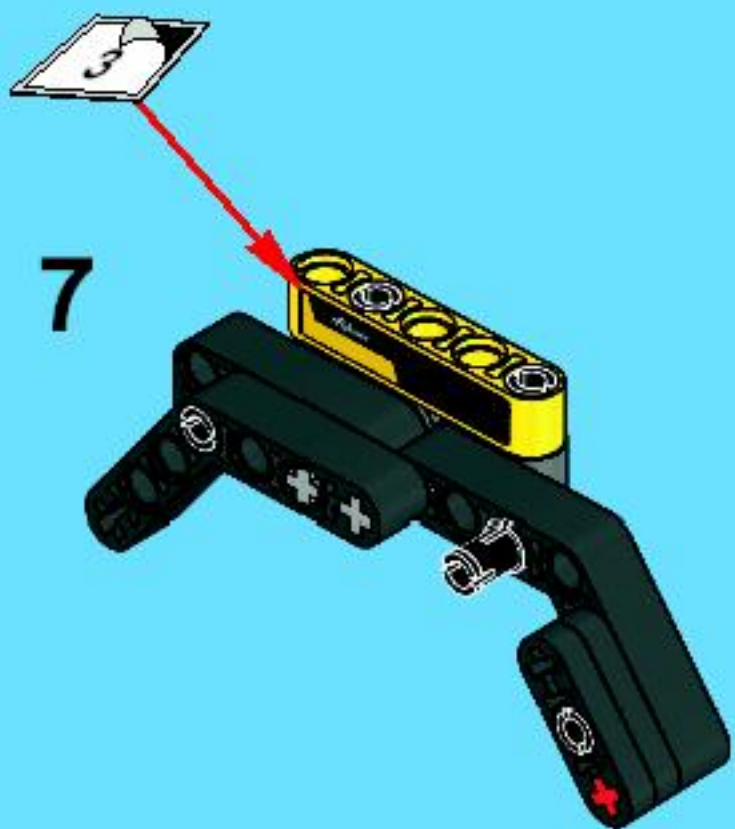
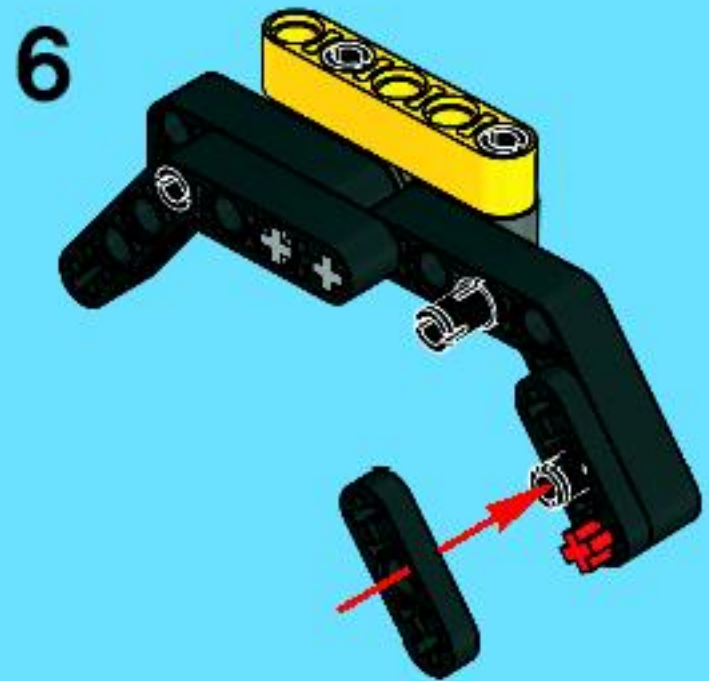



2x

48

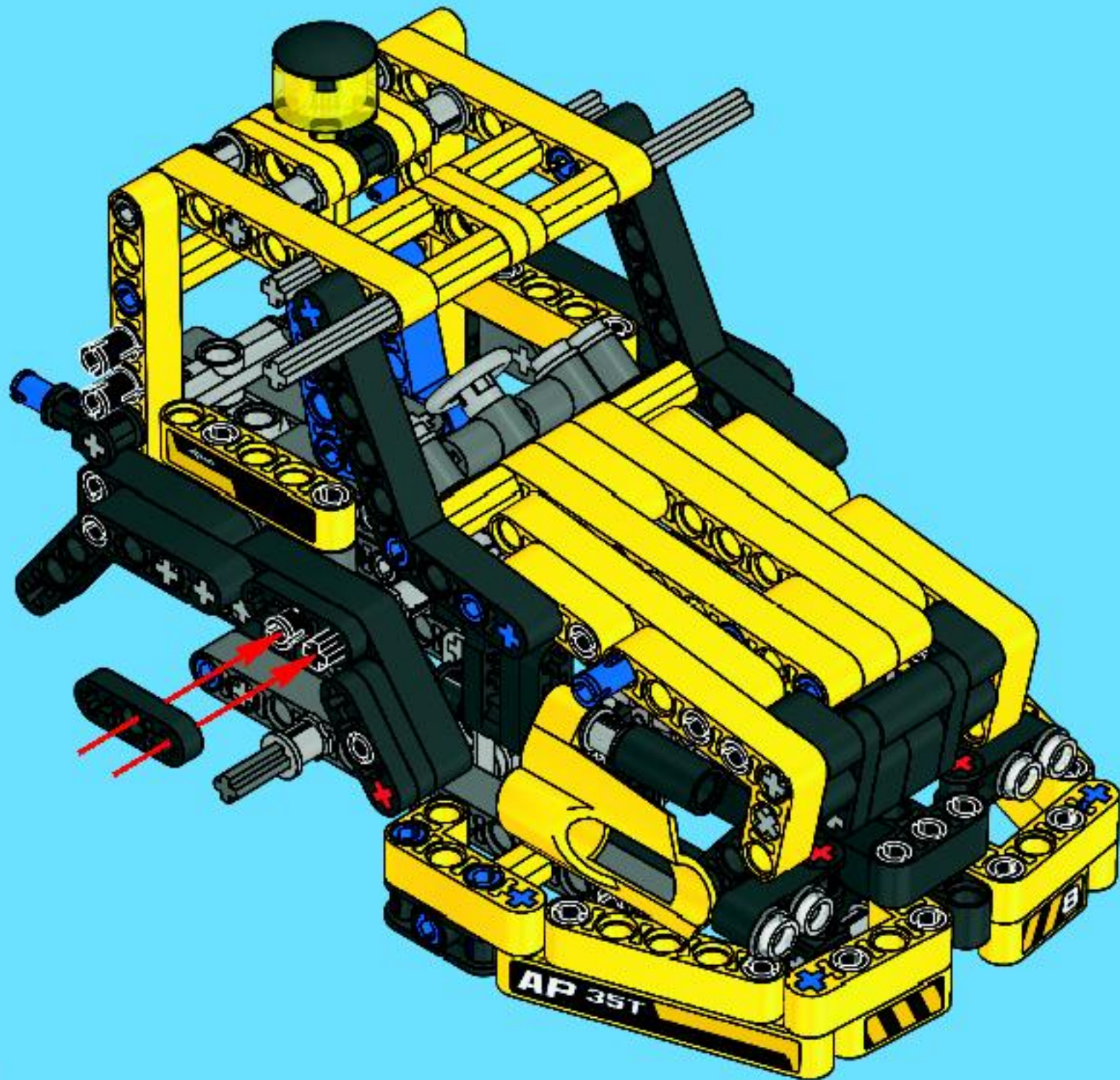

1x



1x



1x

49

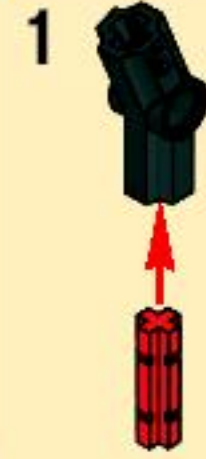

1



2

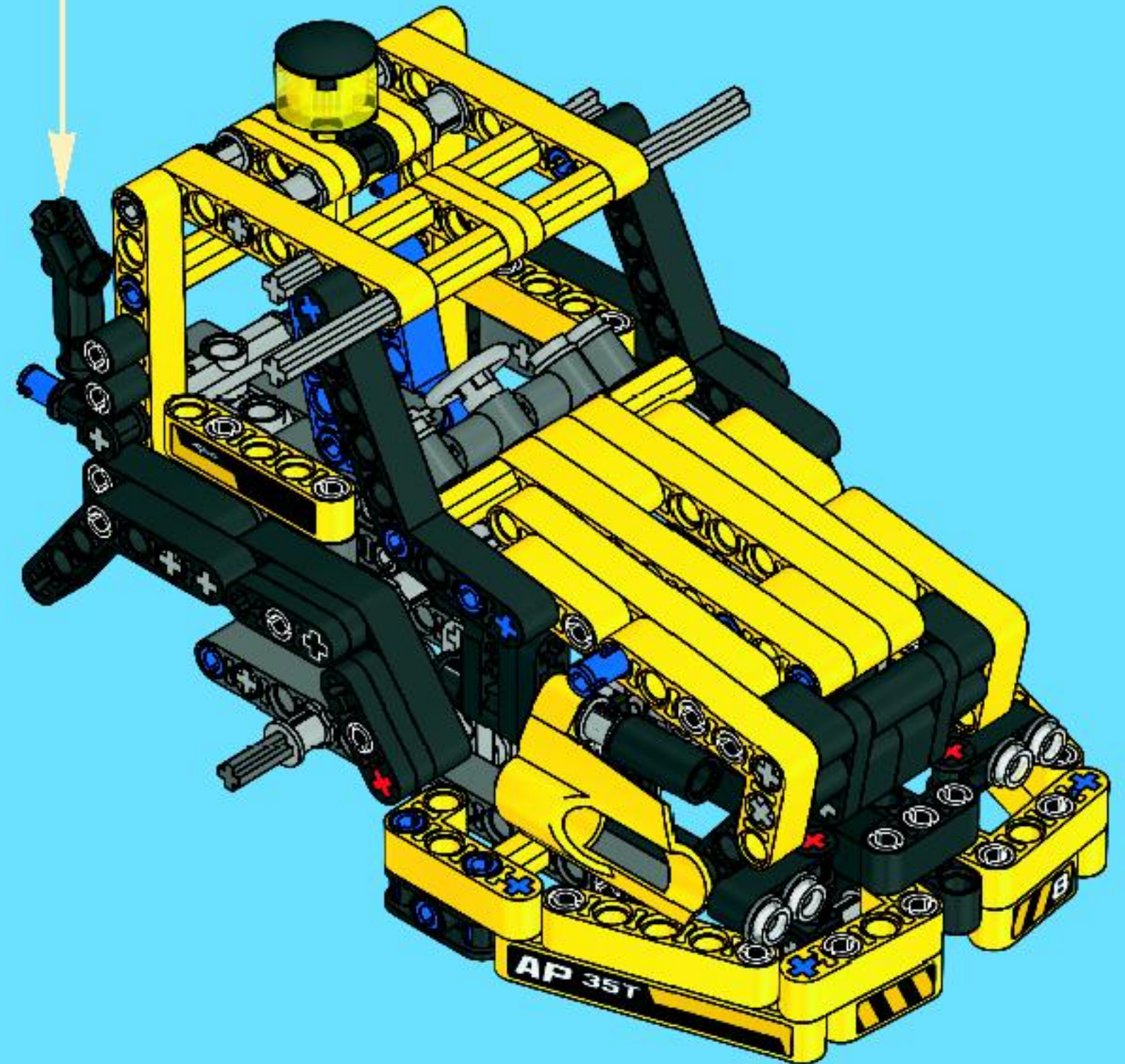

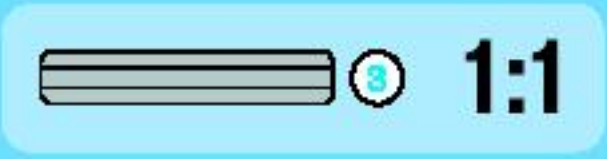
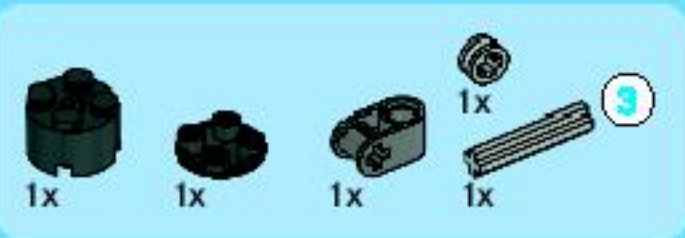

50

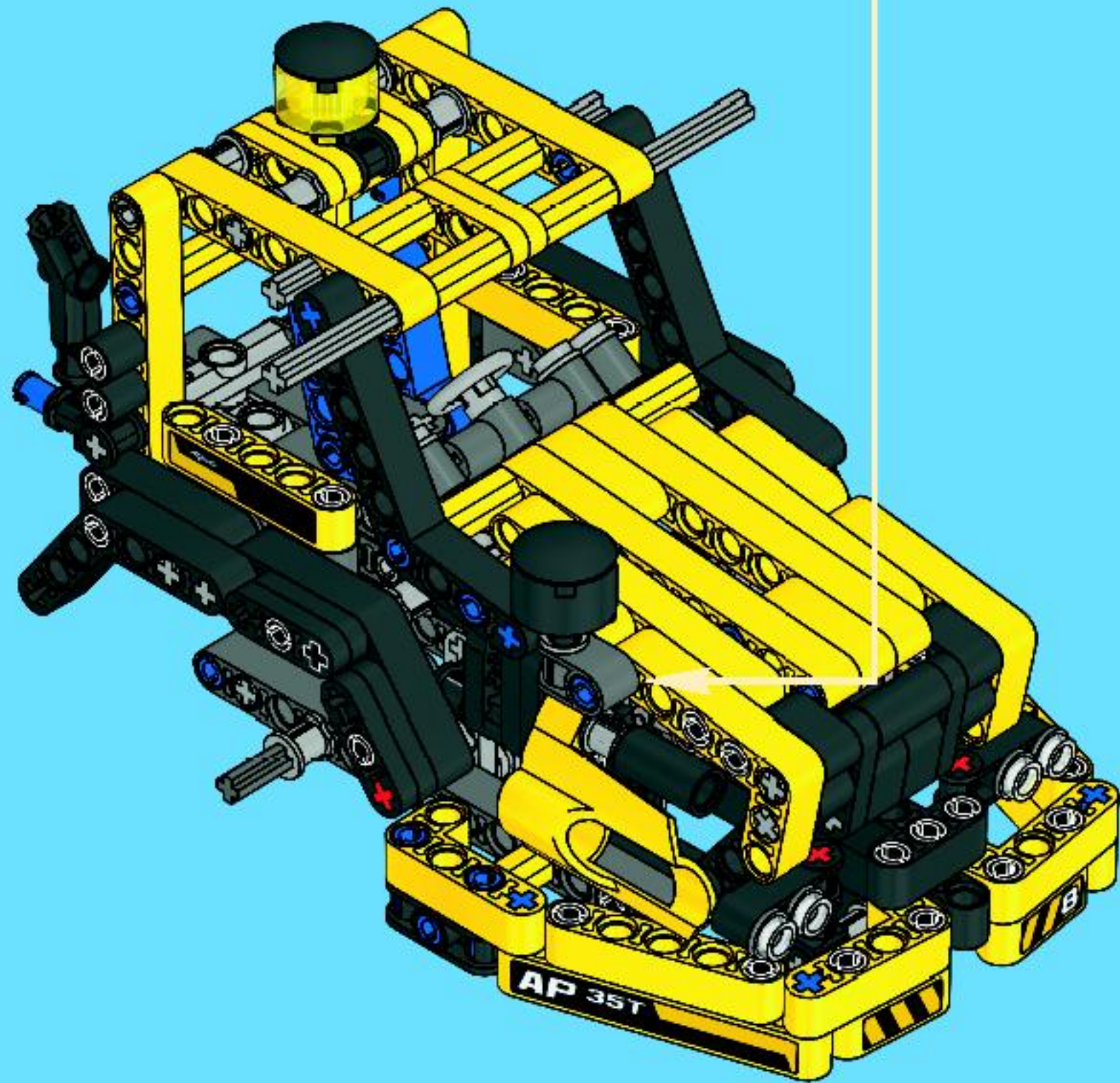
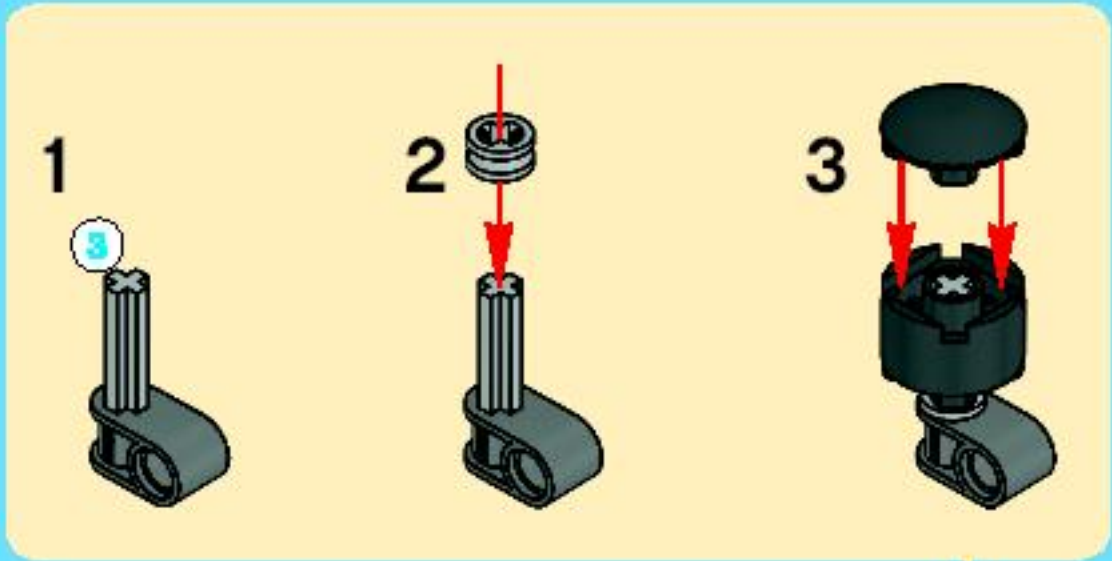

51

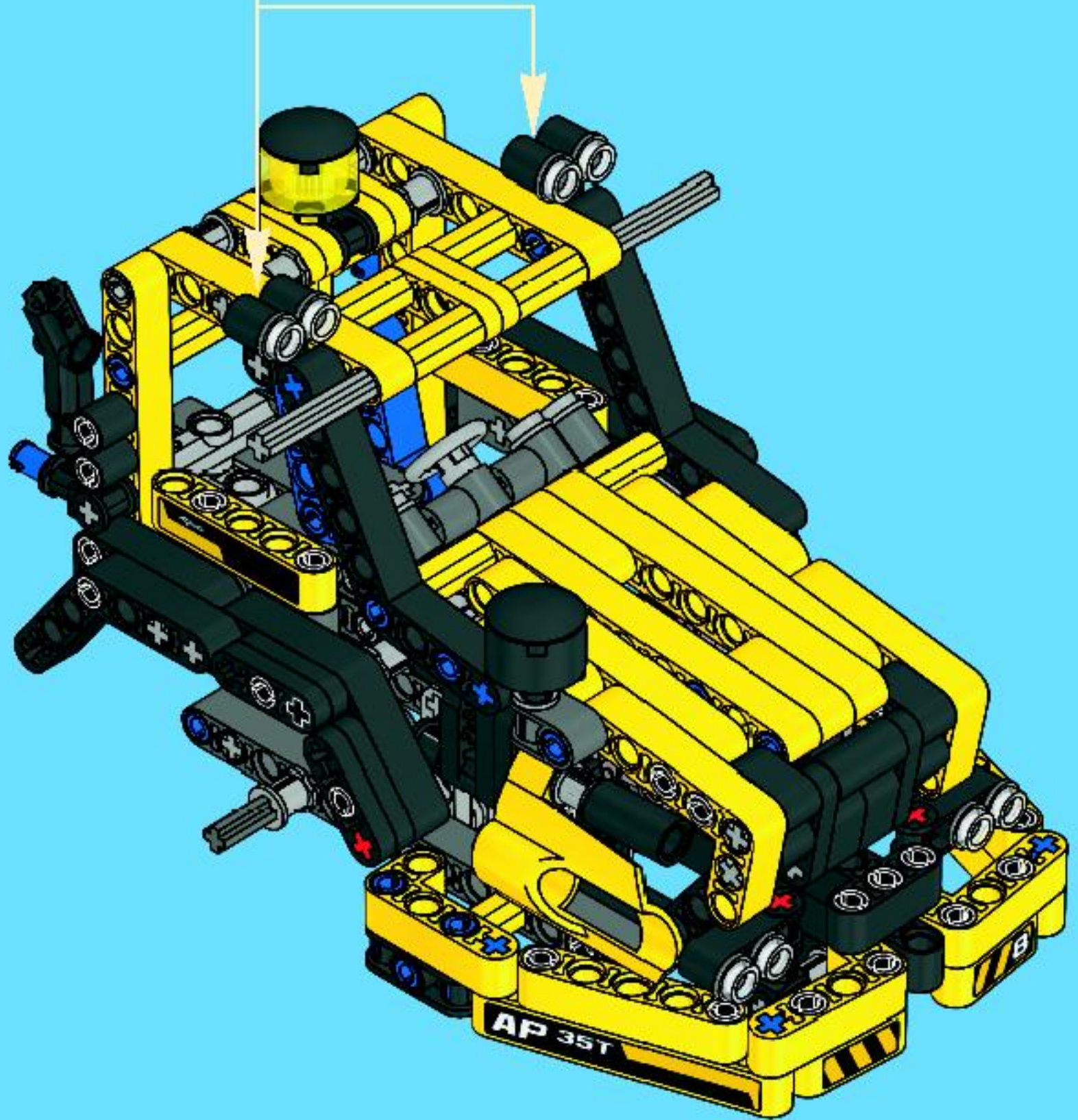
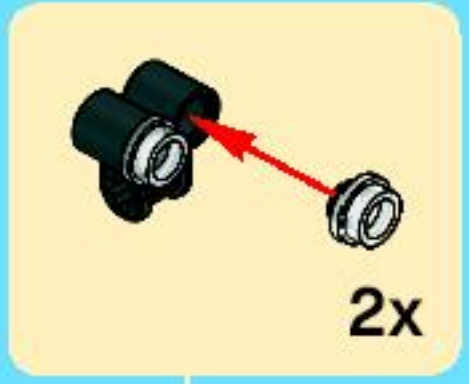



52

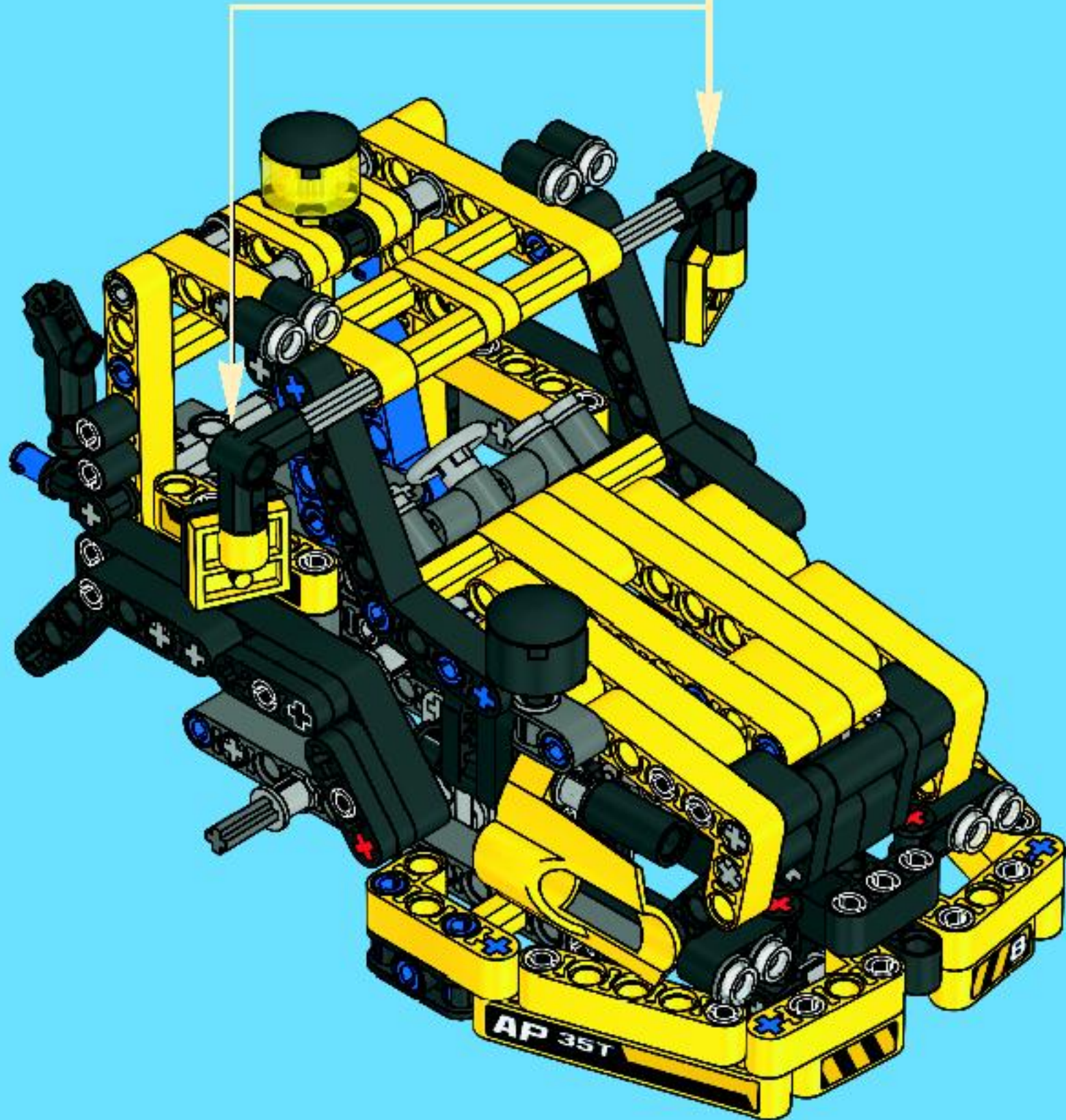
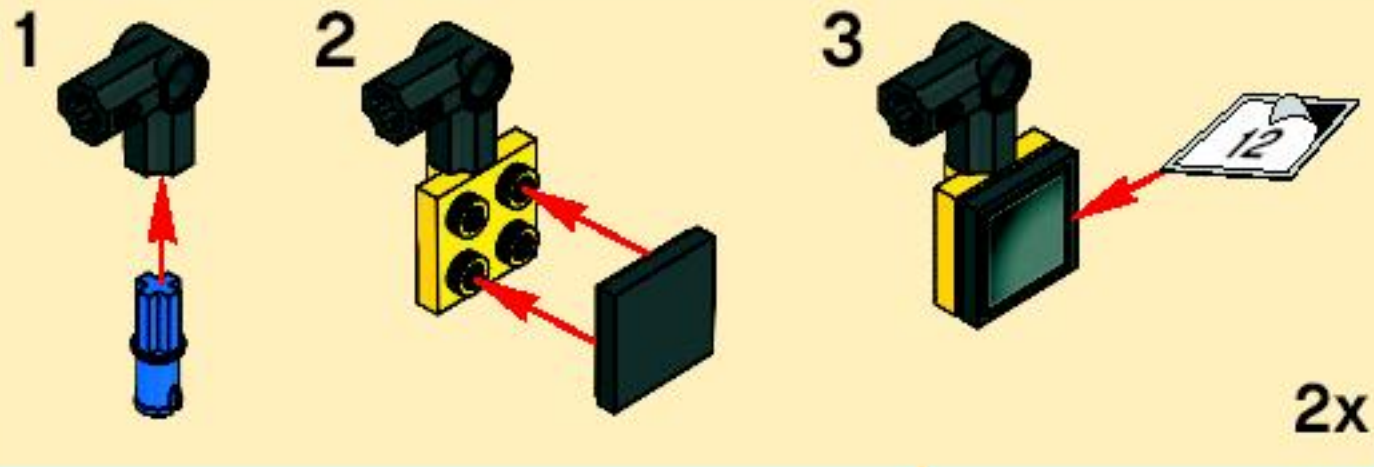

53

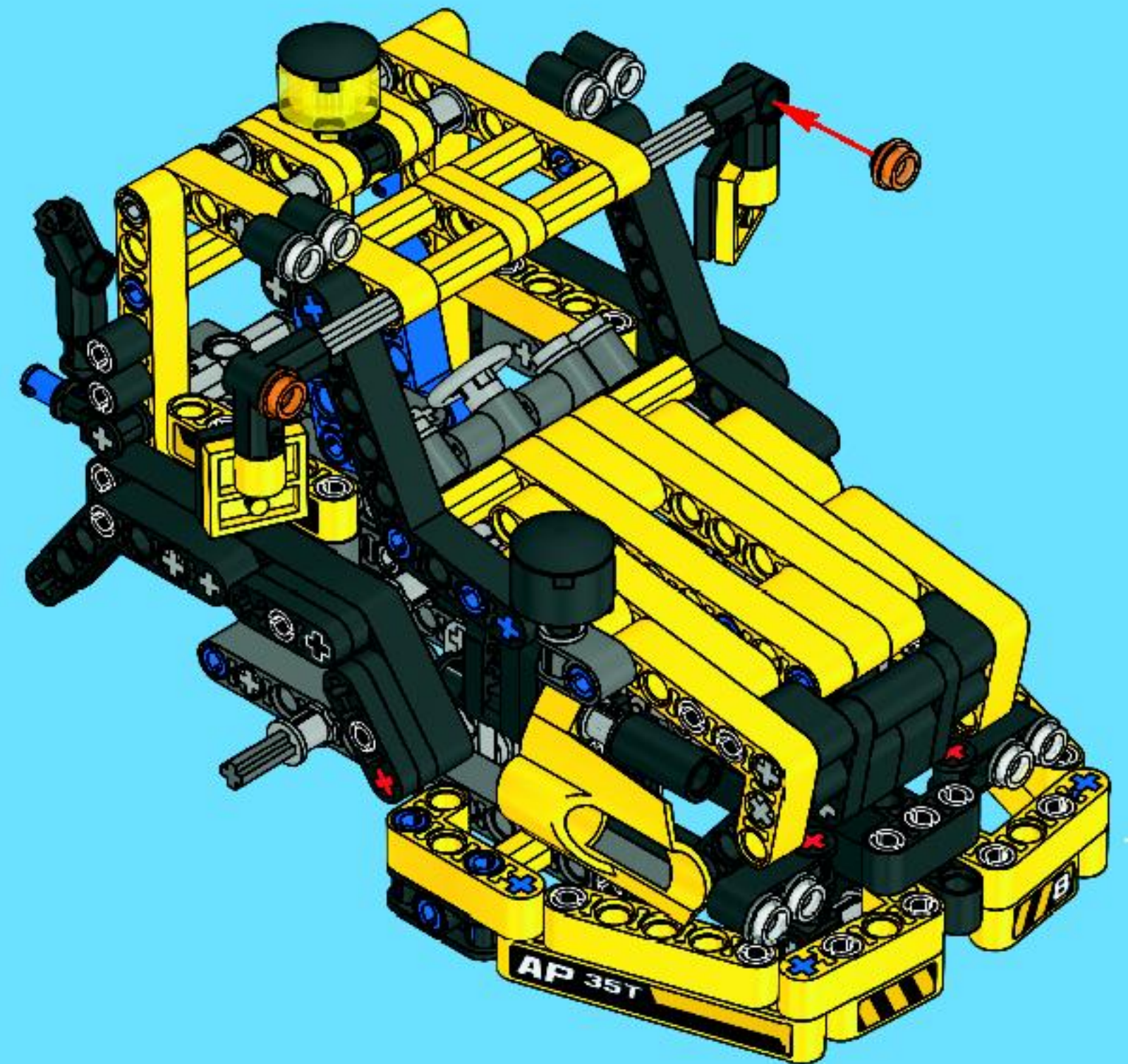

54

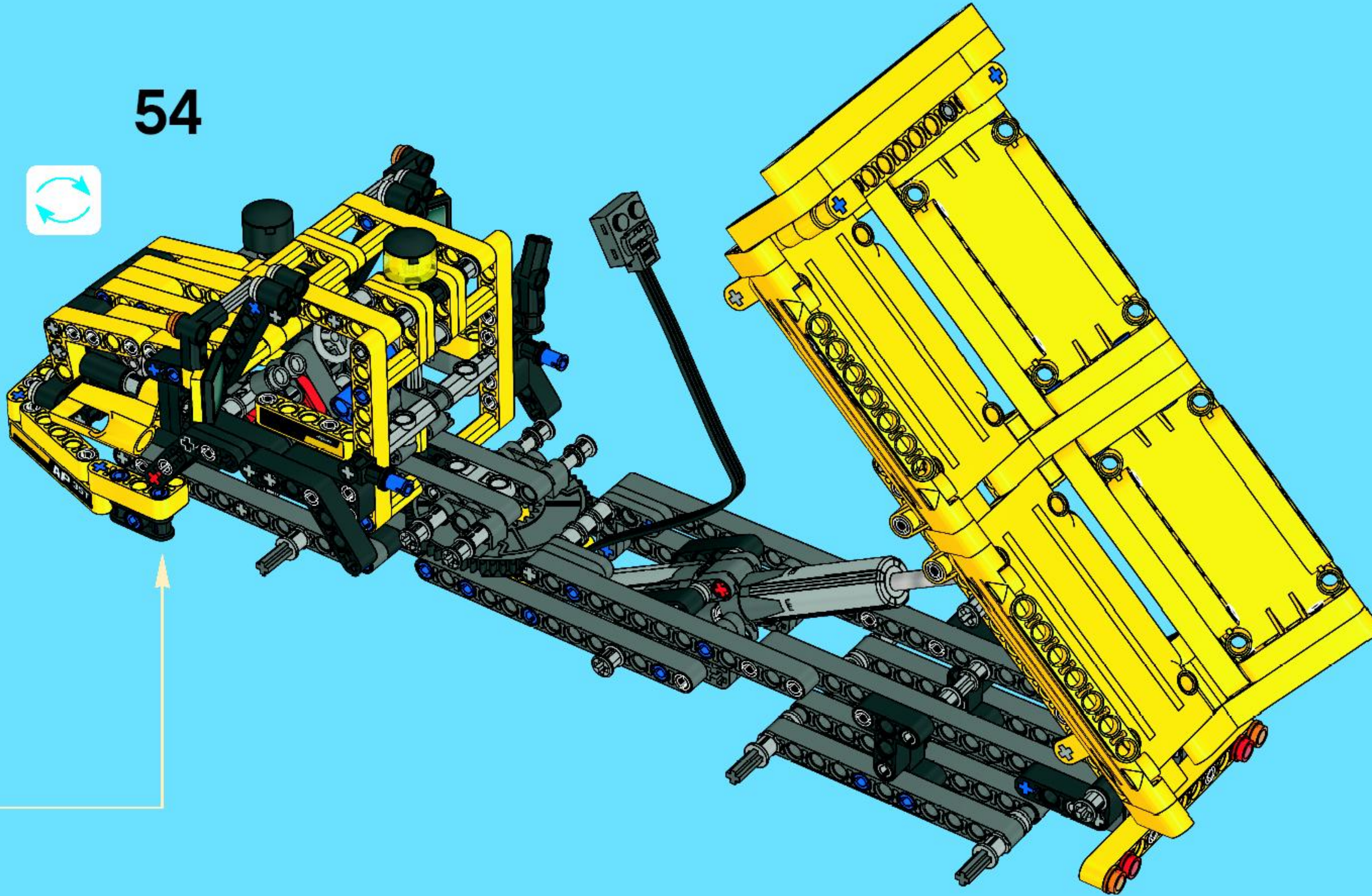

55

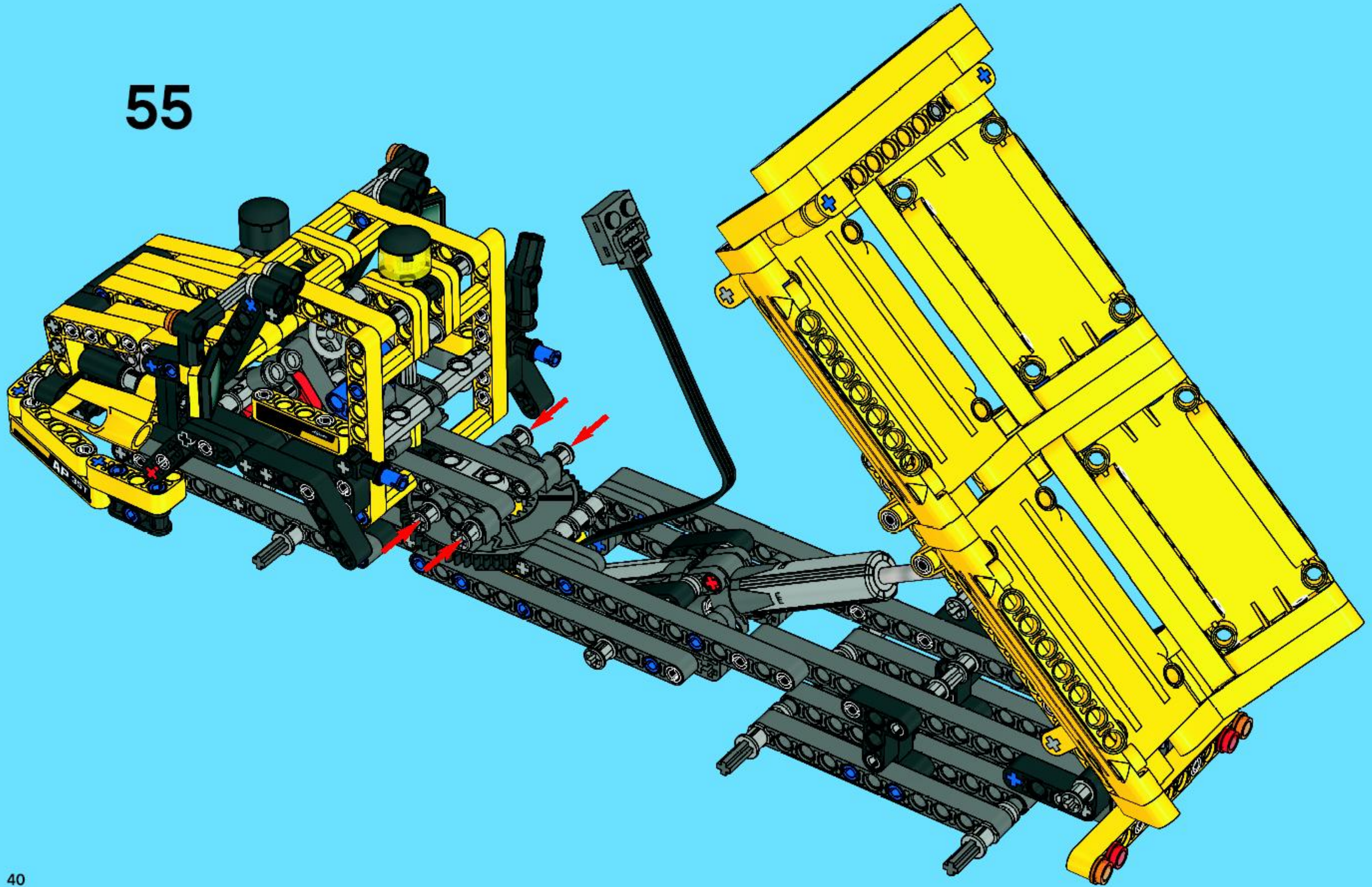



56

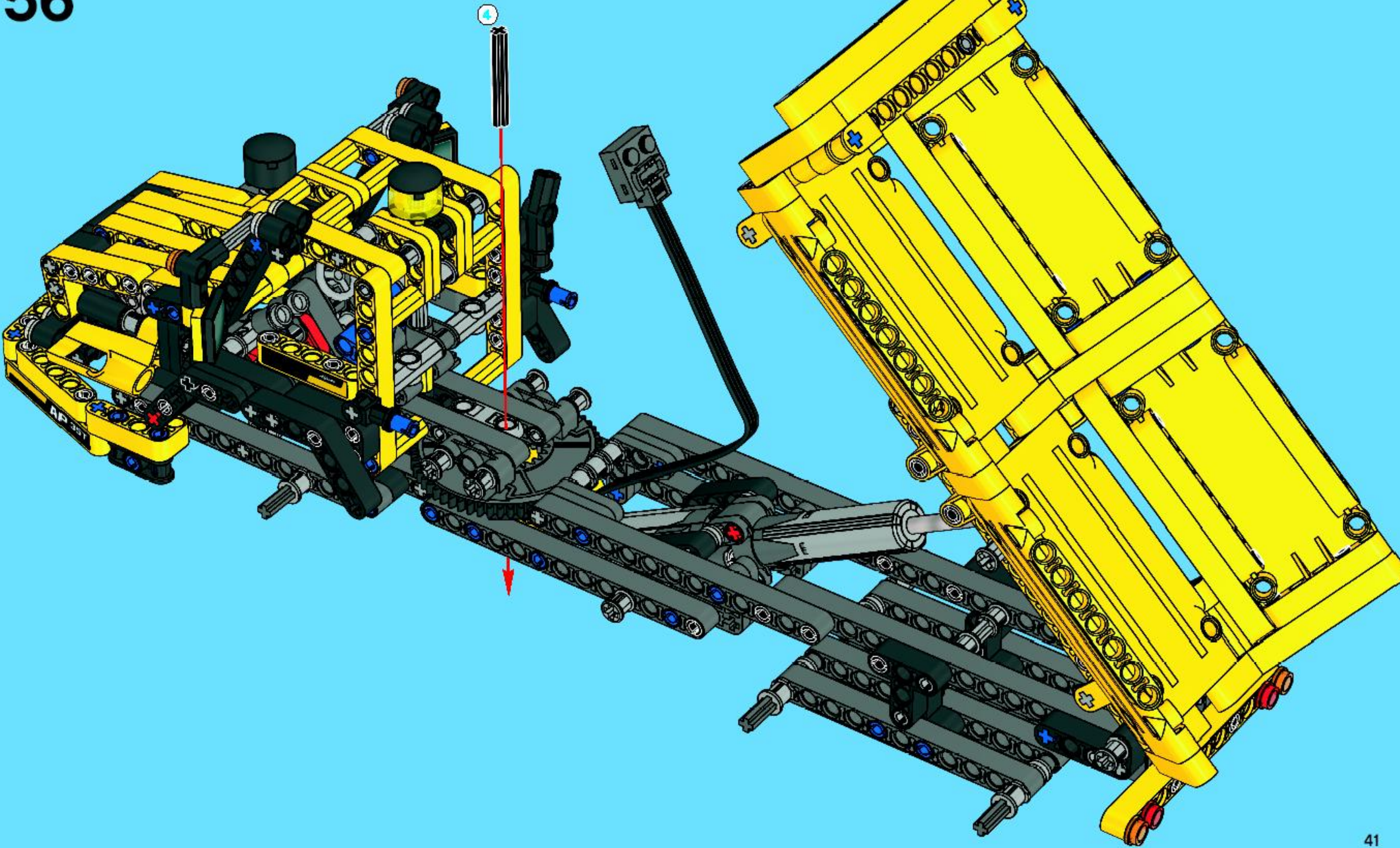

57

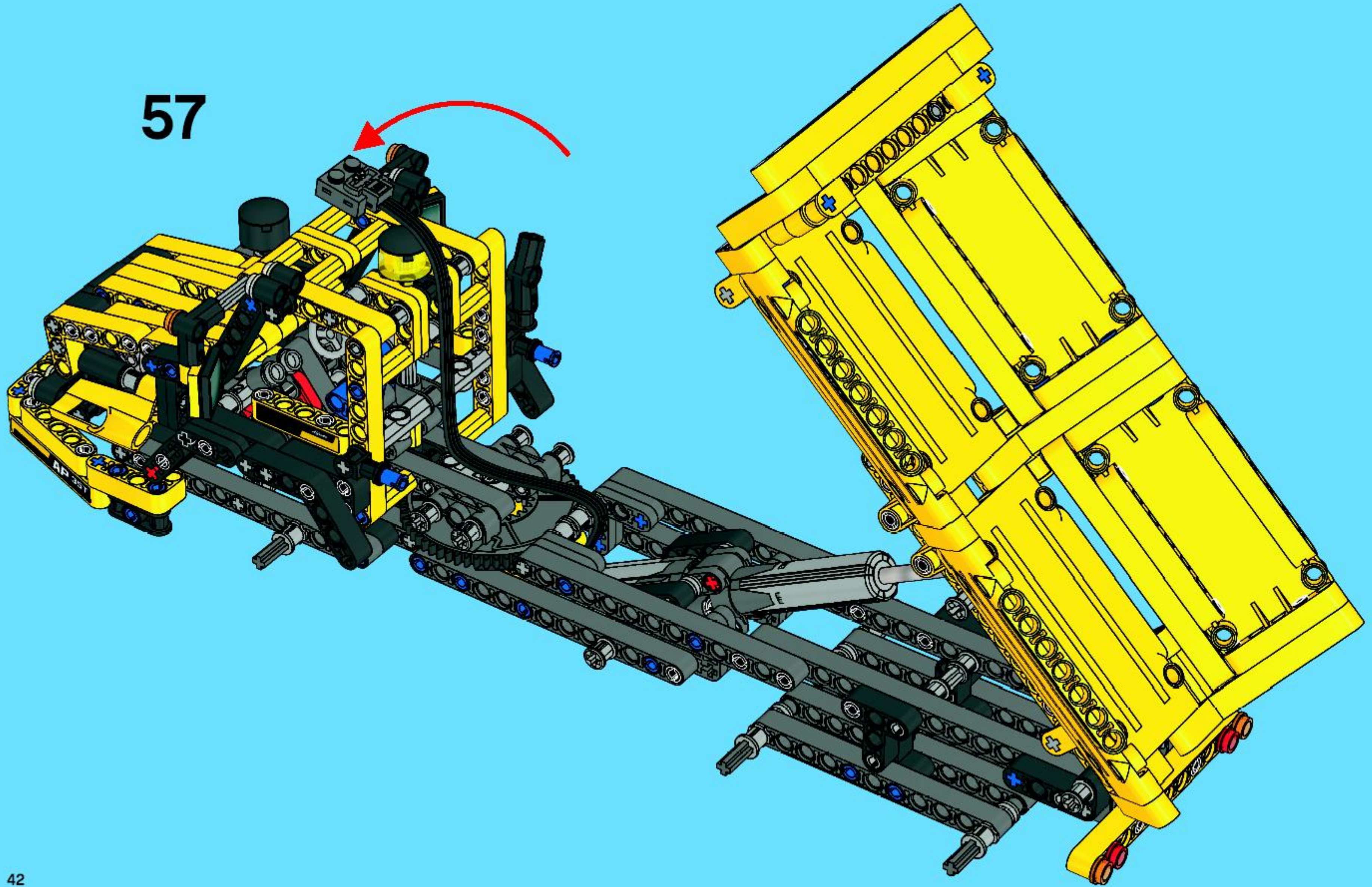

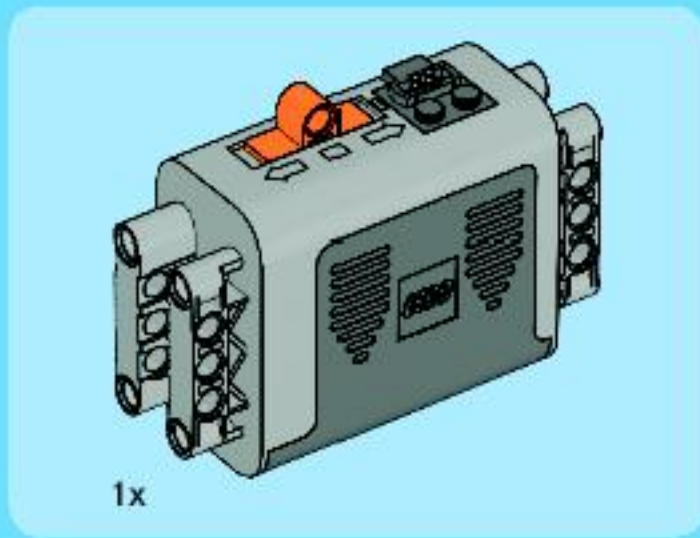

58

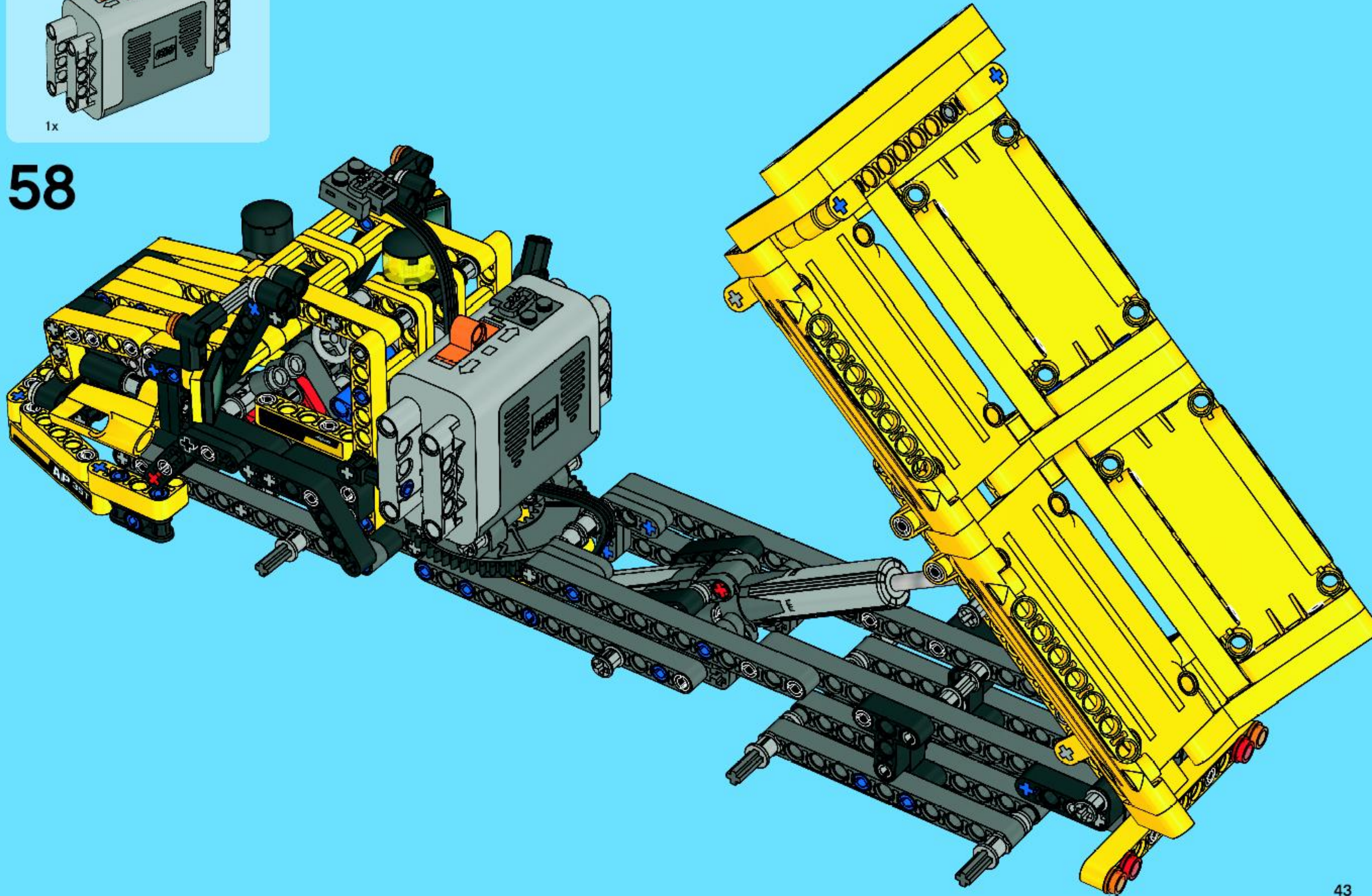

59

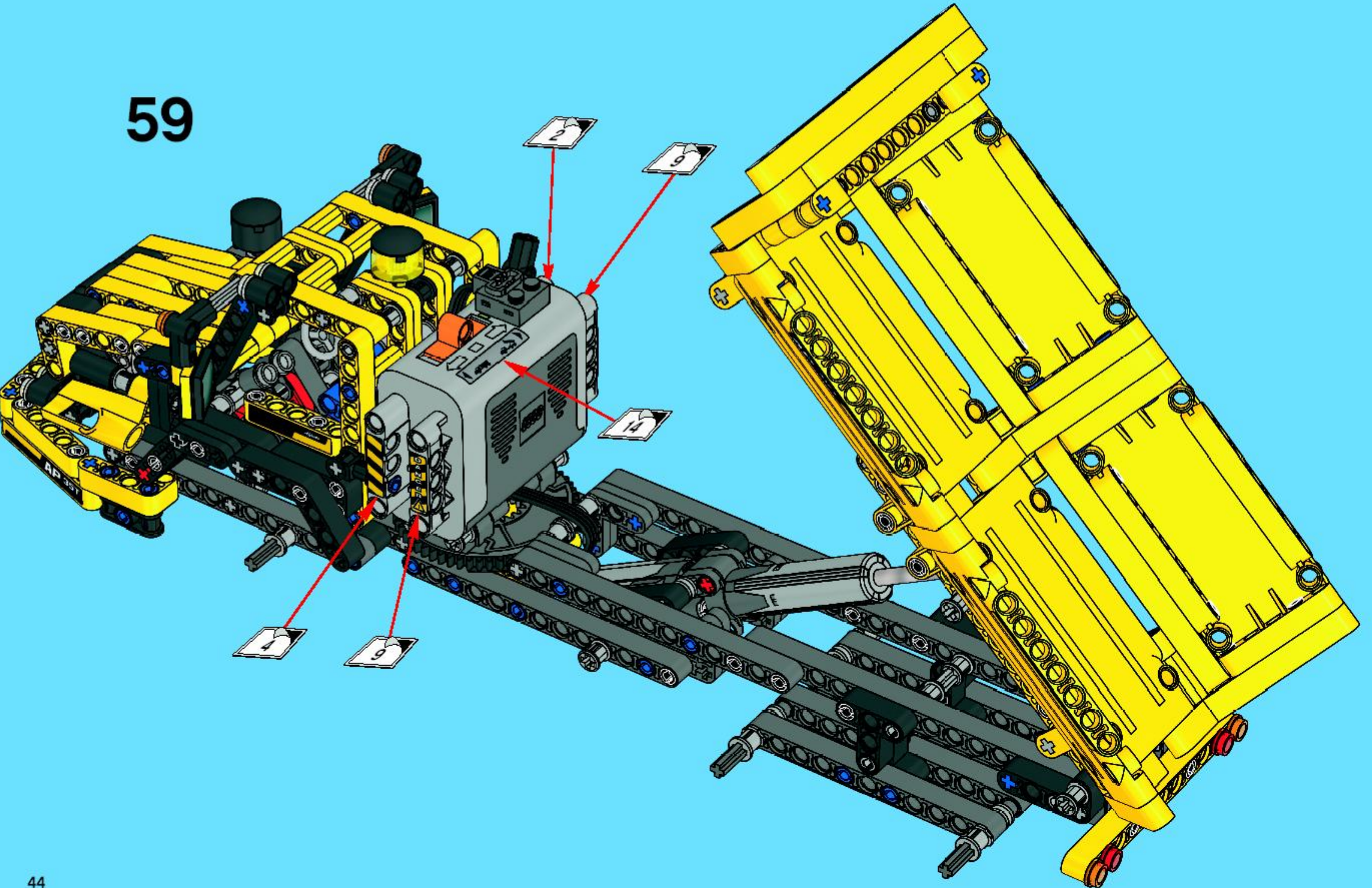

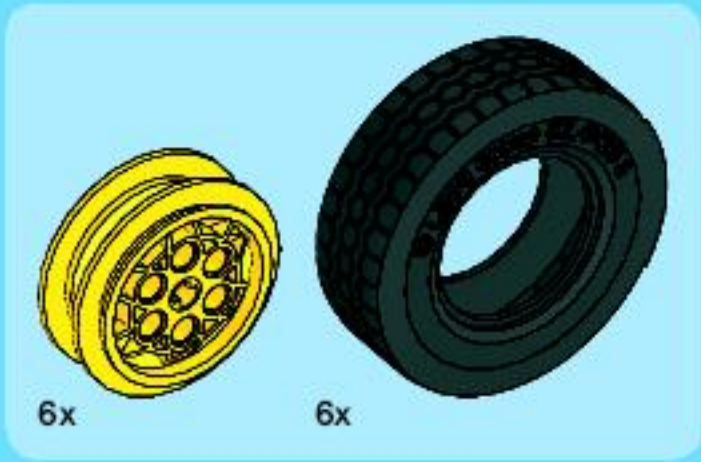

60





Customer Service
 Kundenservice
 Service Consommateurs
 Servicio Al Consumidor
www.lego.com/service or dial
 00800 5346 5555 :     
 1-800-422-5346 :  

FREE! GRATIS! GRATUIT!



club
MAGAZINE™

www.LEGOclub.com



00800 5346 5555*



1-866-534-6258 • 1-877-518-5346

US & Canada only

Canada seulement

VISIT THE WORLD'S
BIGGEST LEGO® SHOP!

www.LEGOshop.com

* Freephone. Mobile charges may apply. * Numéro sans frais. Des frais peuvent s'appliquer avec les téléphones cellulaires. * Gebührenfrei, kostenpflichtig für Mobilfunknetze können abweichen. * Gratiskaldtalaftalningur er aðskiljanleg. * Kostnadsgratis numéris, vanda ringer frá þóttakafni. * Kostnadsgratis, náðu ringer frá þóttakafni.

WIN LEGO® PRODUCTS

Fill out a survey and you might WIN a cool LEGO product!
NO PURCHASE NECESSARY
Open to all residents where not prohibited
Go to www.acnielsen.aim.dk/LEGO to fill out a survey for a chance to win a LEGO product.

WIN LEGO® PRODUCTEN

Vul een enquêteformulier in en maak kans op een cool LEGO® product!
Kopen niet nodig
Iedereen uit landen waar geen enquêteverbod geldt mag deelnemen.
Ga naar www.acnielsen.aim.dk/LEGO, vul een enquêteformulier in en maak kans op een LEGO product.

GEWINNE LEGO® PRODUKTE

Nimm an der Umfrage teil und GEWINNE ein tolles LEGO® Produkt!
Die Teilnahme am Gewinnspiel führt zu keinerlei Kaufverpflichtungen
Teilnahme in allen nicht ausgeschlossenen Ländern möglich
Wir verlosen unter allen Teilnehmern der Umfrage auf www.acnielsen.aim.dk/LEGO LEGO Produkte.

GAGNE DES PRODUITS LEGO®

Réponds à un questionnaire et tu pourras GAGNER un produit LEGO® très cool !
Aucune obligation d'achat.
Ouvert à tous les résidents des pays autorisés.
Visite www.acnielsen.aim.dk/LEGO pour répondre à un questionnaire et avoir une chance de gagner un produit LEGO.

レゴ®製品を「当てよう」

アンケートに記入して、カッコいいレゴ®製品を当てよう！
お買い上げの必要はありません。禁止されていない限り、すべての皆様にご利用いただけます。
www.acnielsen.aim.dk/LEGOにアクセスして、アンケートにご記入ください。当選者にはレゴ®製品を差し上げます。

www.nielsen.com/LEGO



WIN
WIN
GEWINNE
GAGNE
「当てよう」



 www.LEGO.com

©2009 The LEGO Group. 4549724