

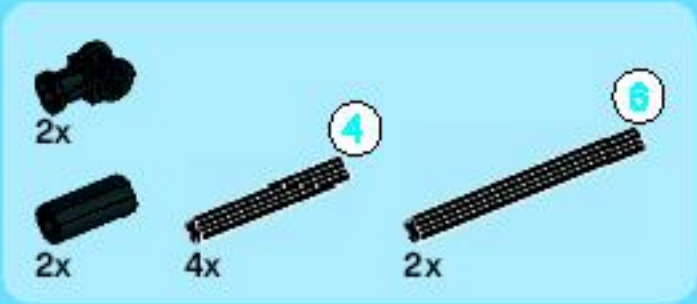

TECHNIC

8265





90

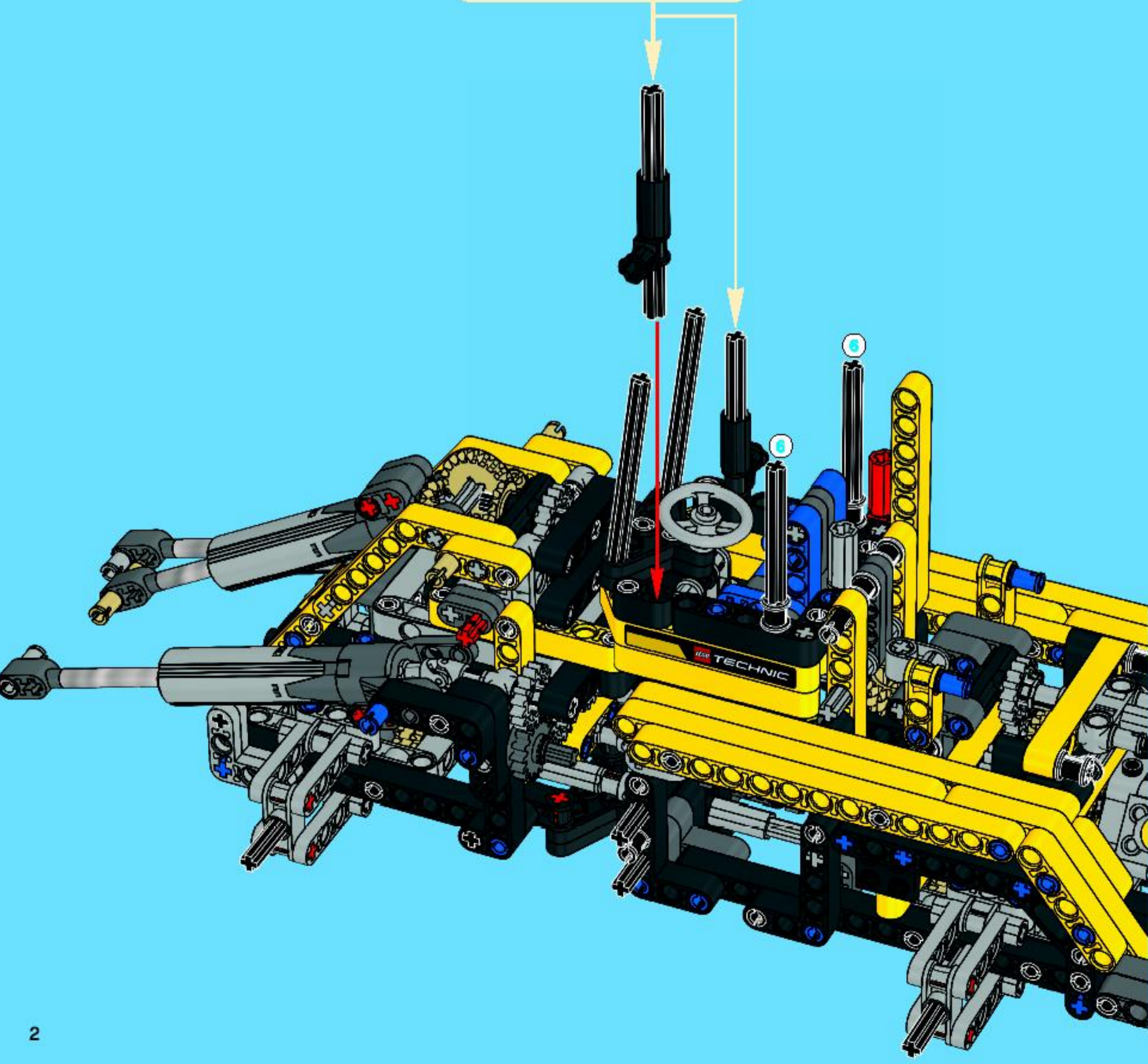
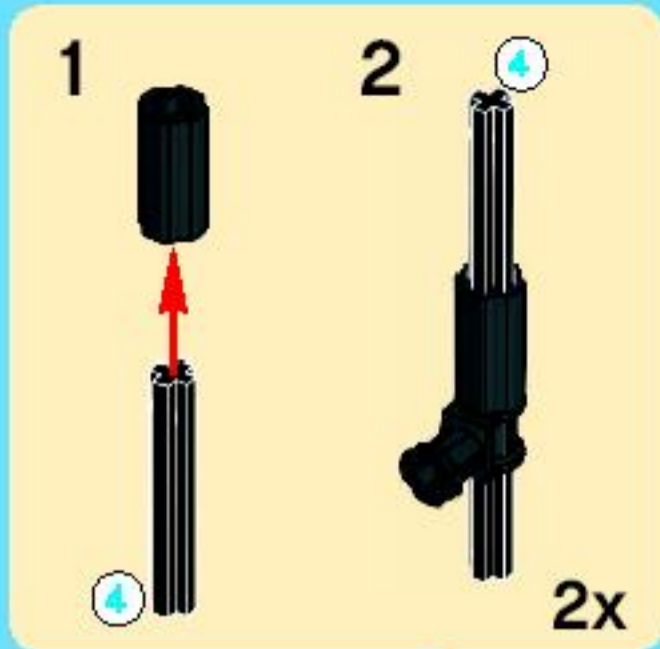

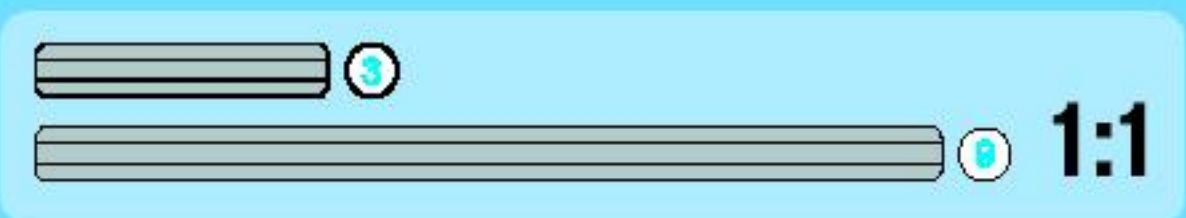
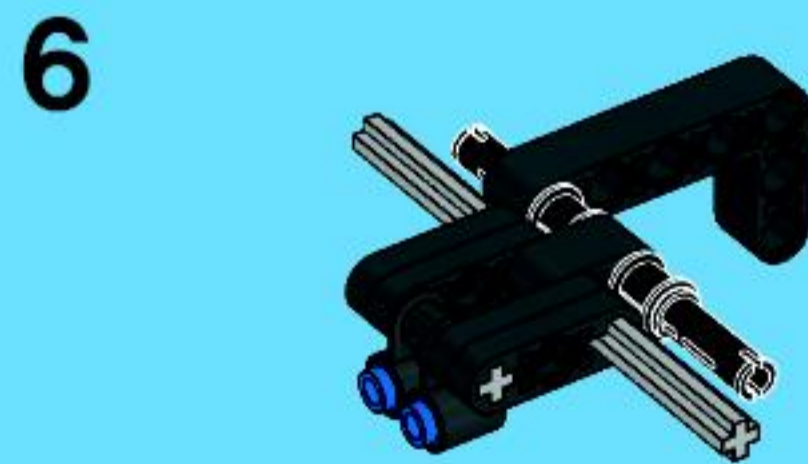
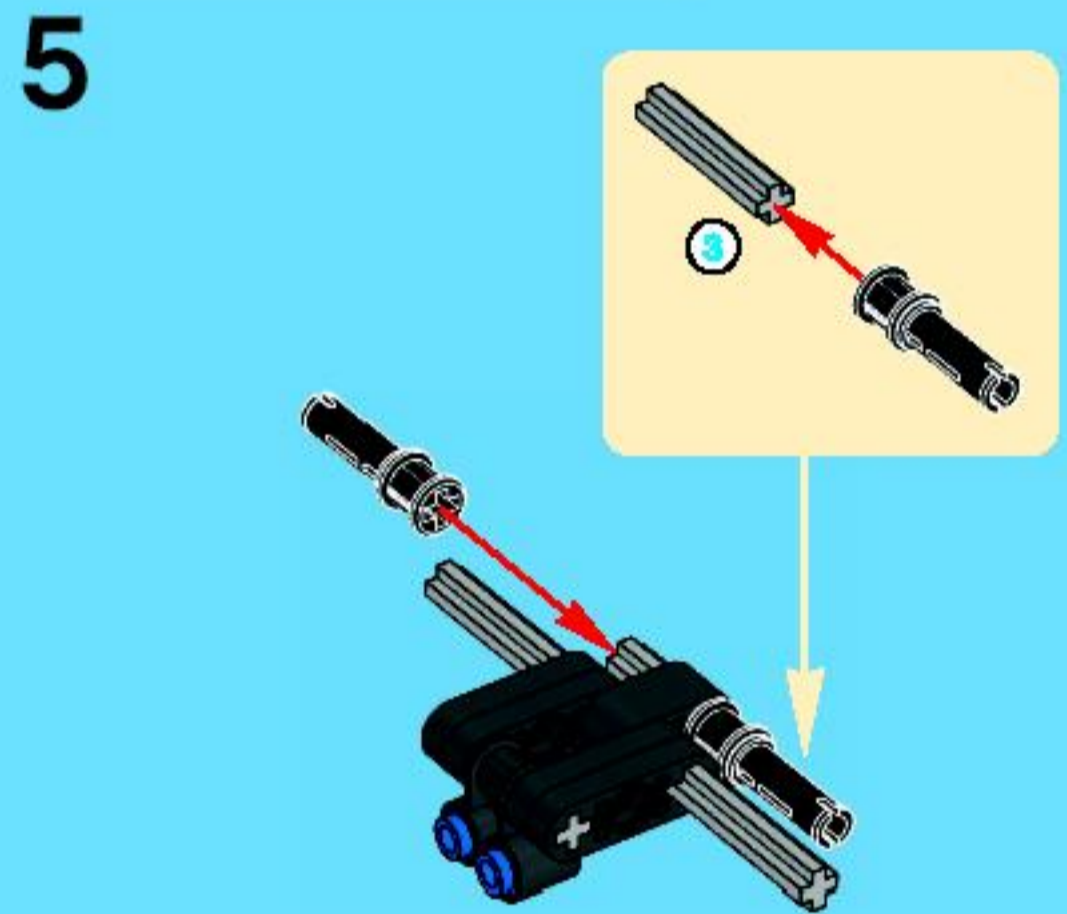
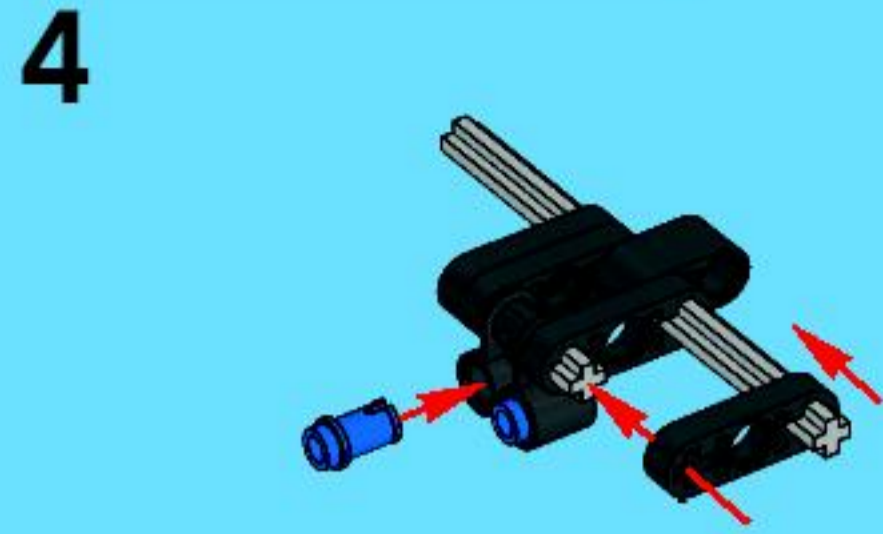
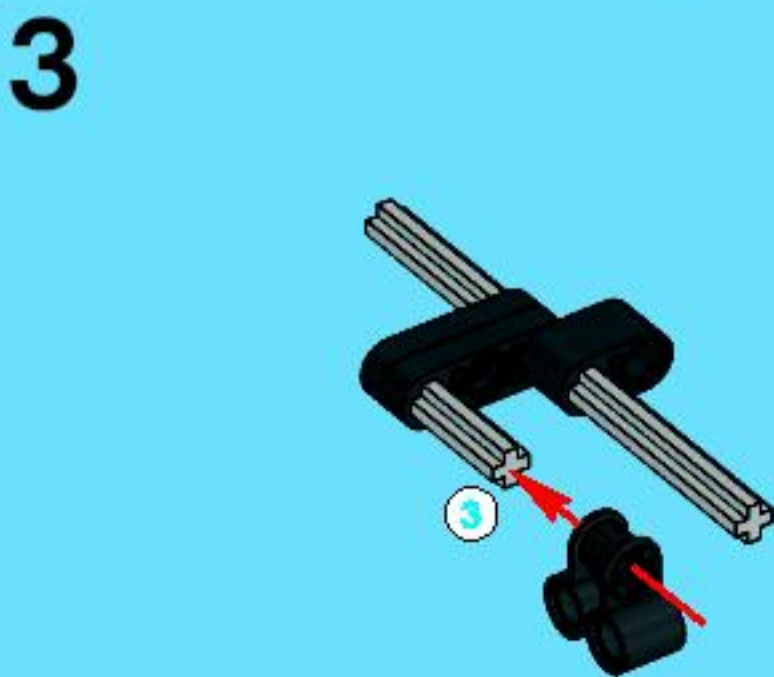
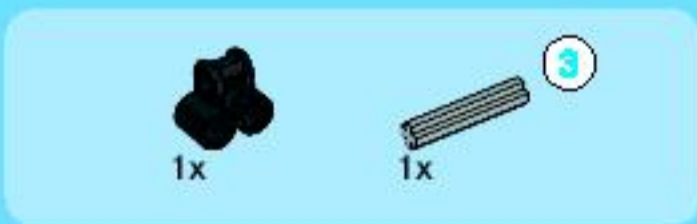
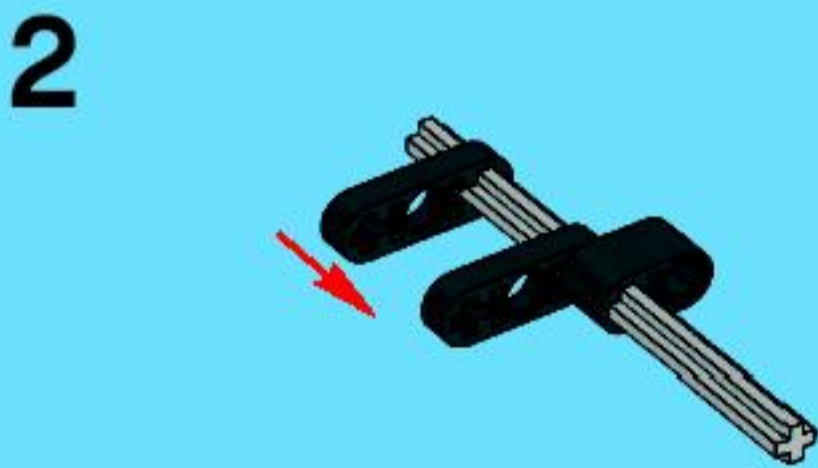
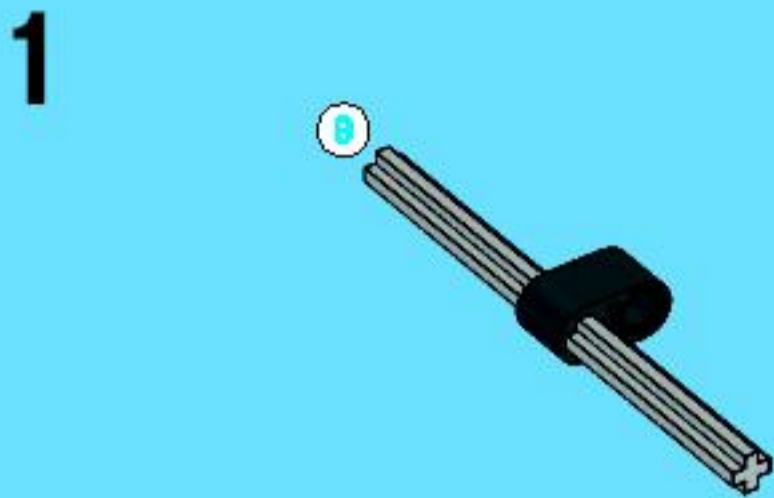
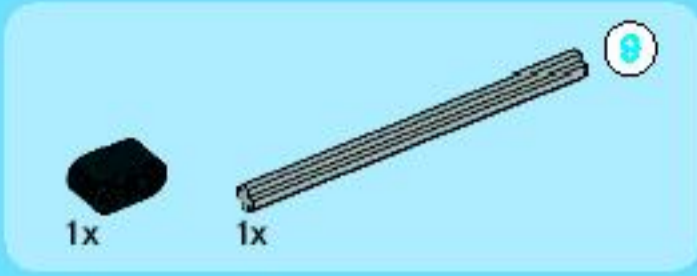



7

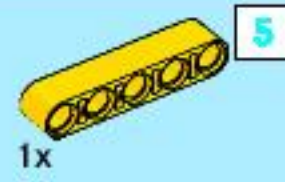
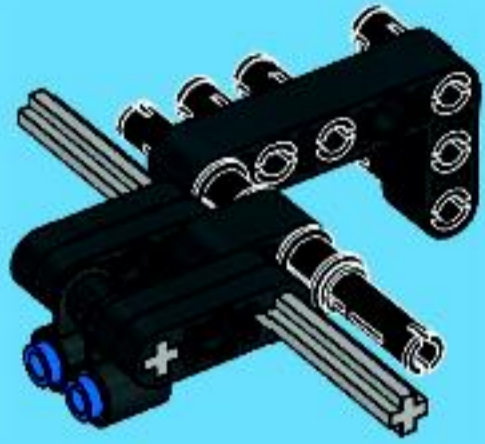

9

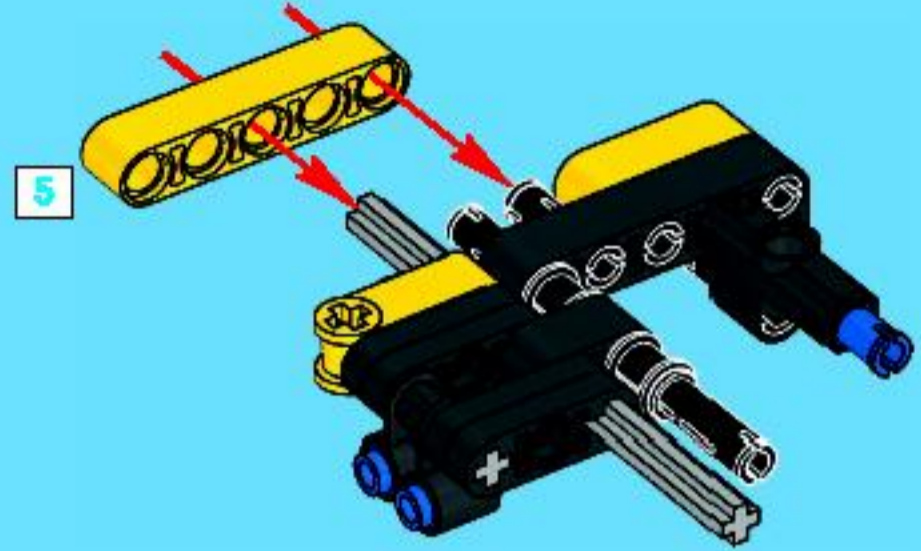

8

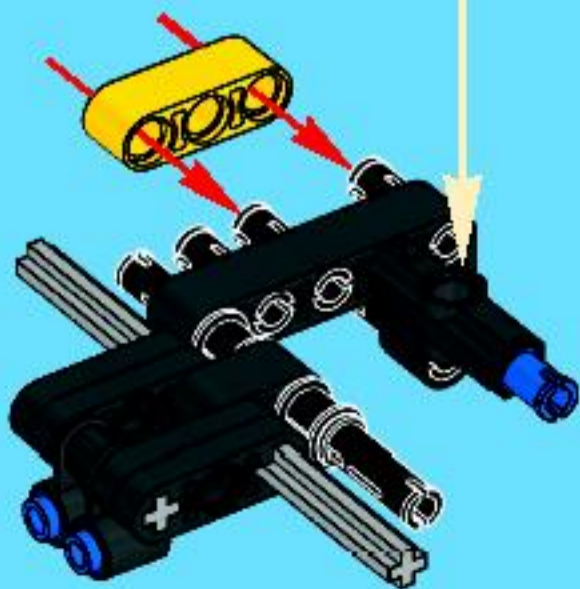

10

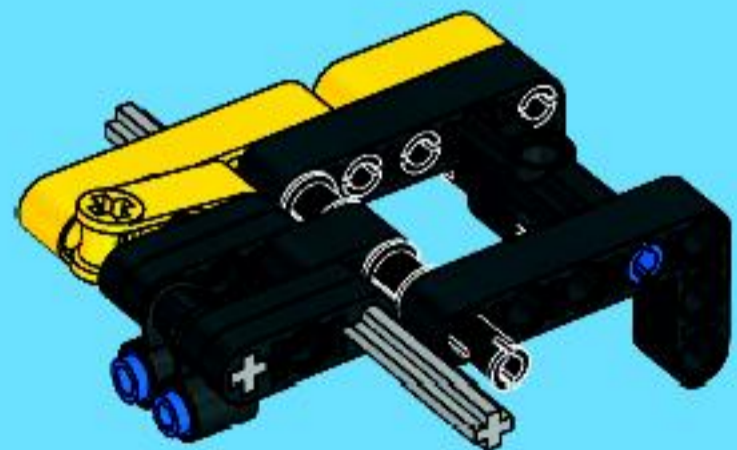

5

1:1

5x



1x

11

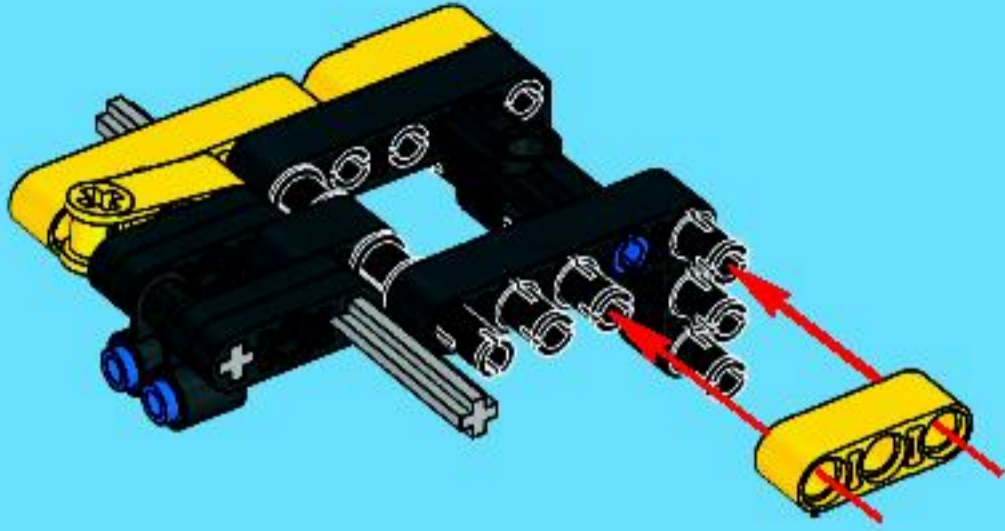

1x



1x

12

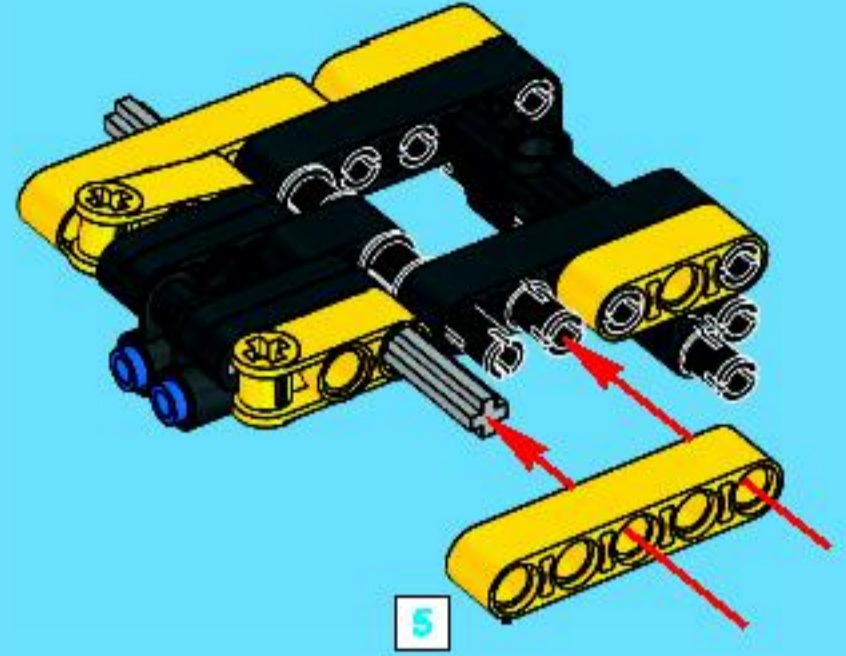

91

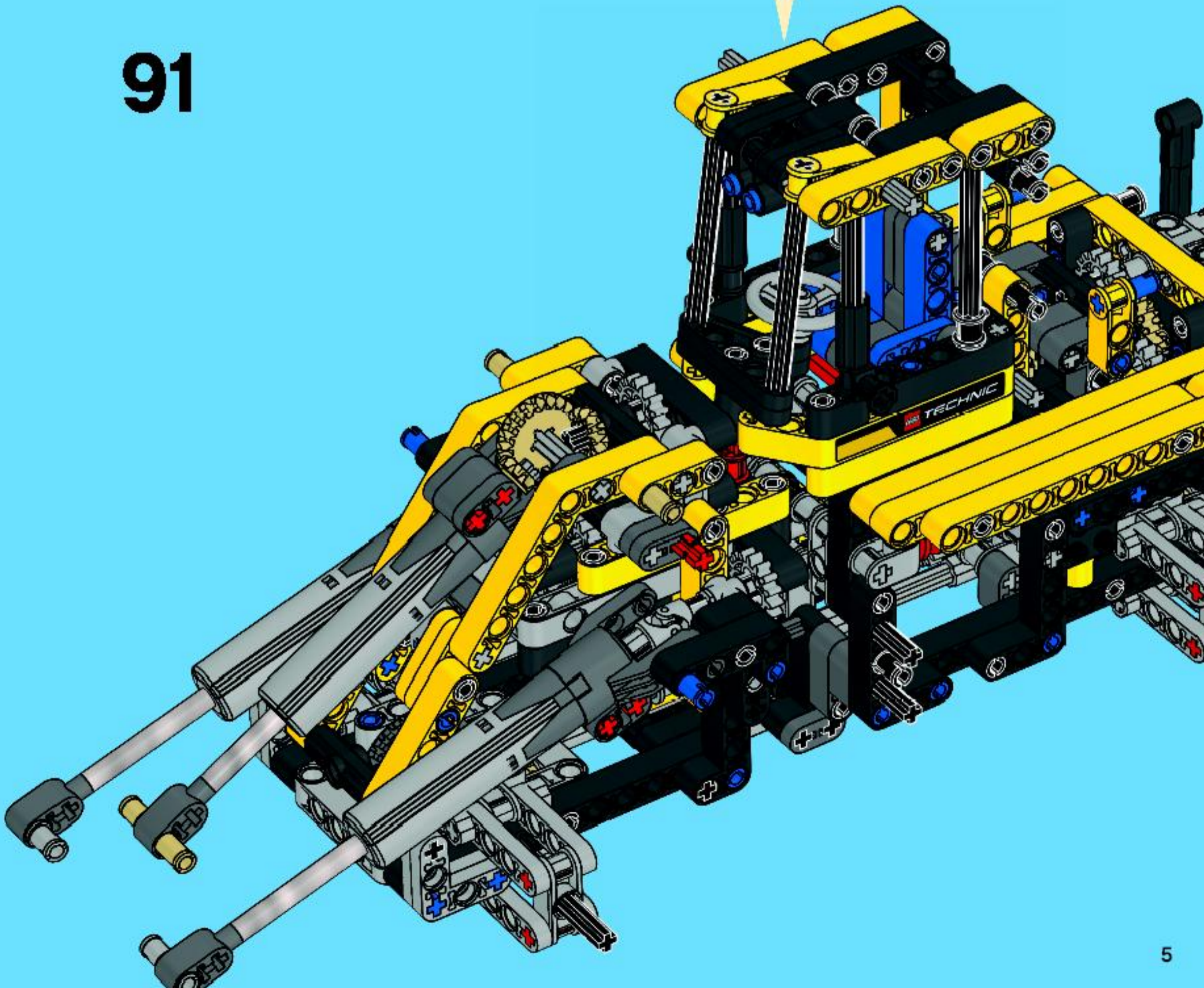

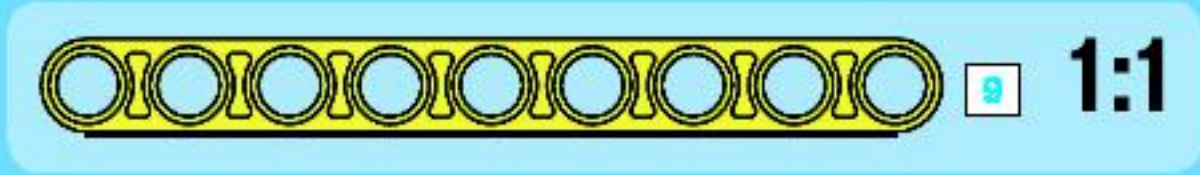
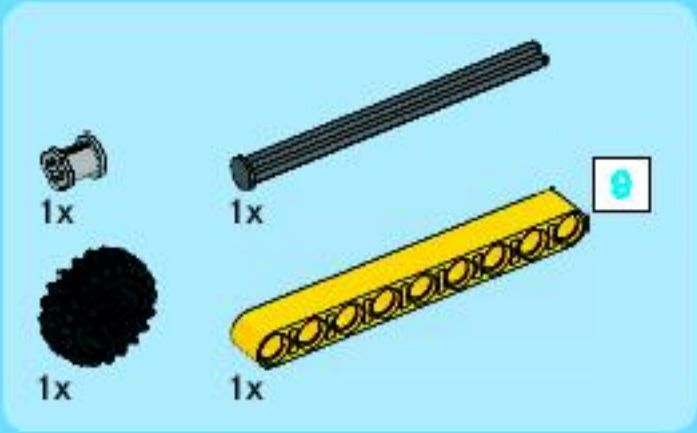

92

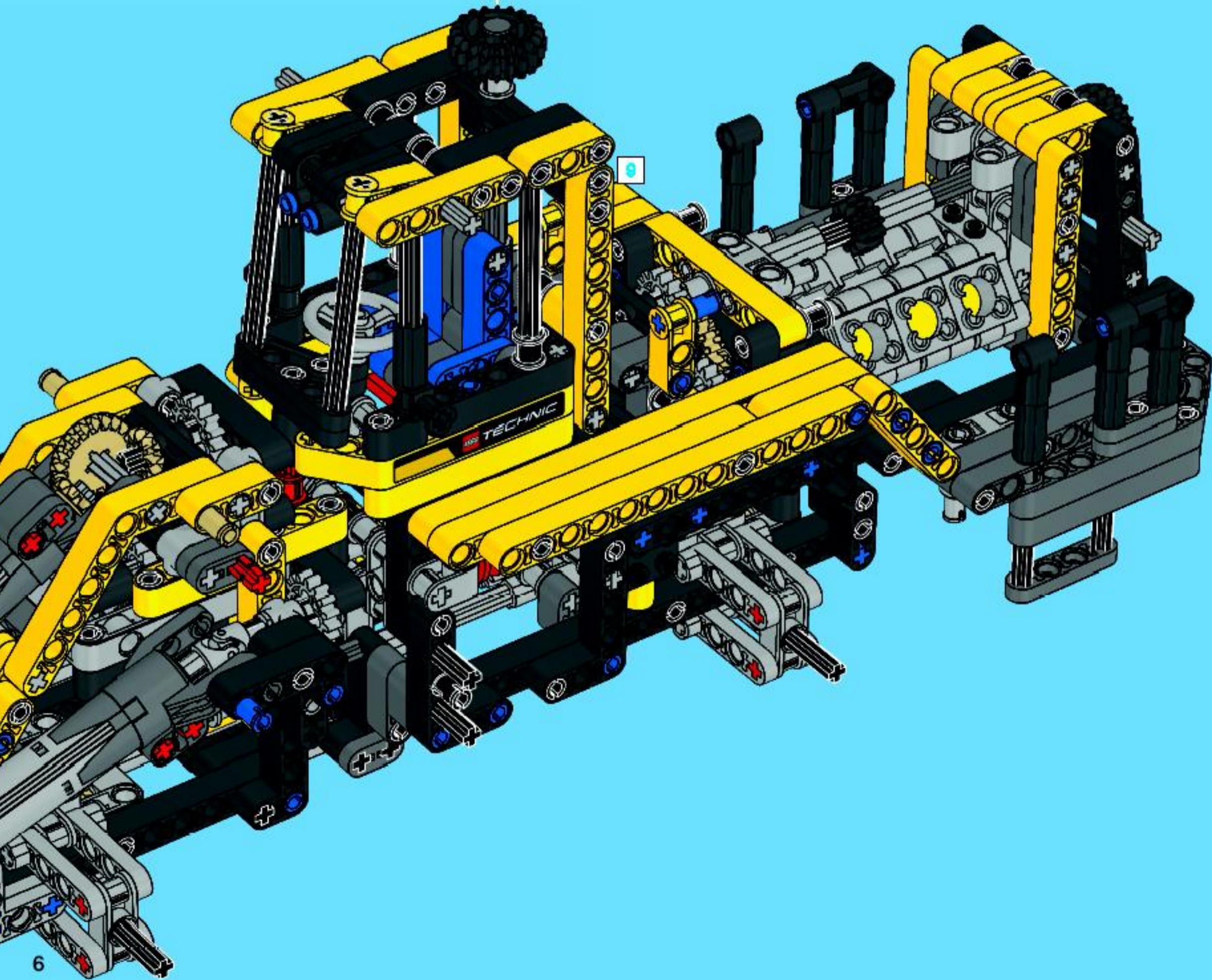
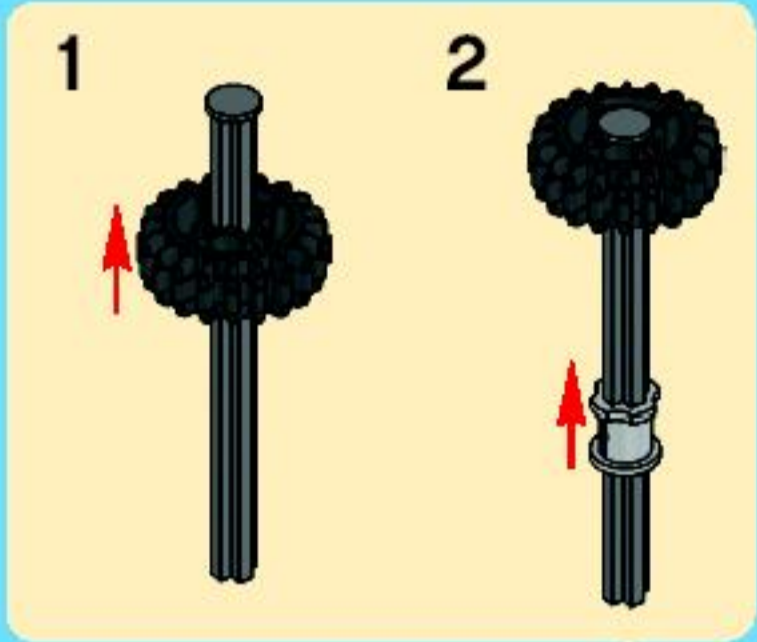



93

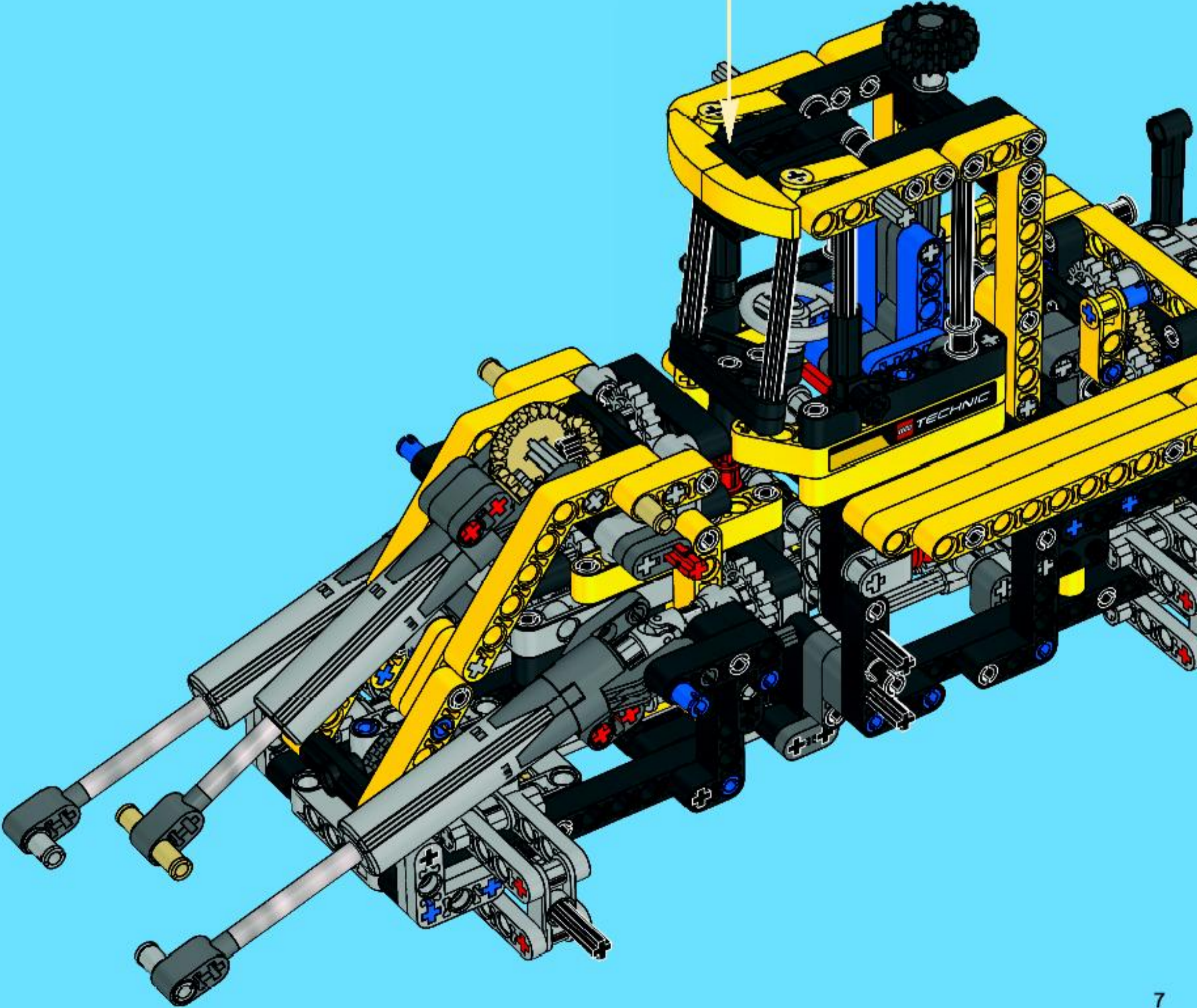
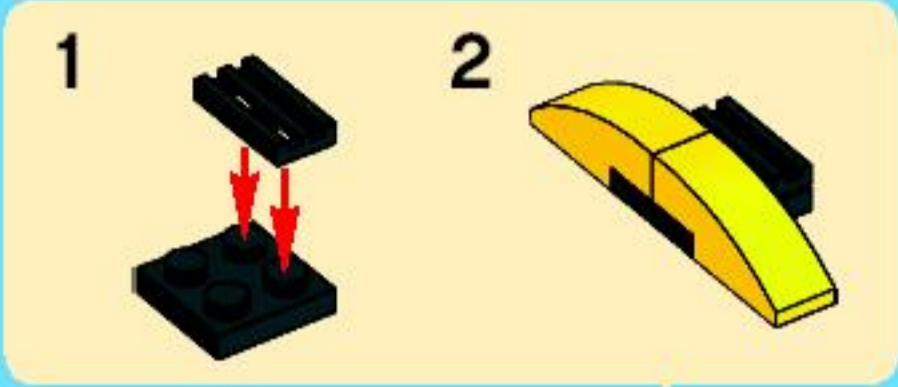

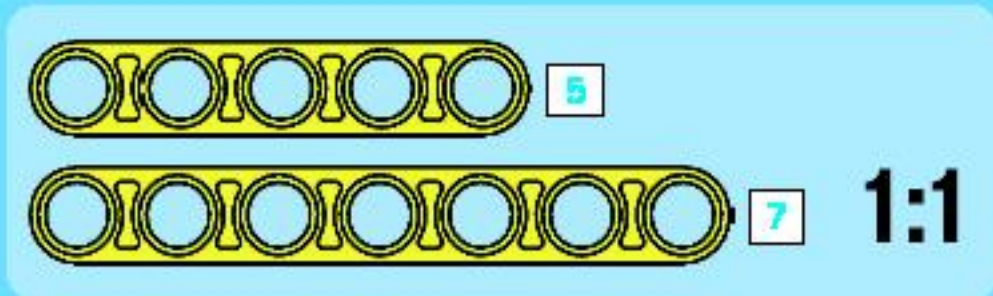
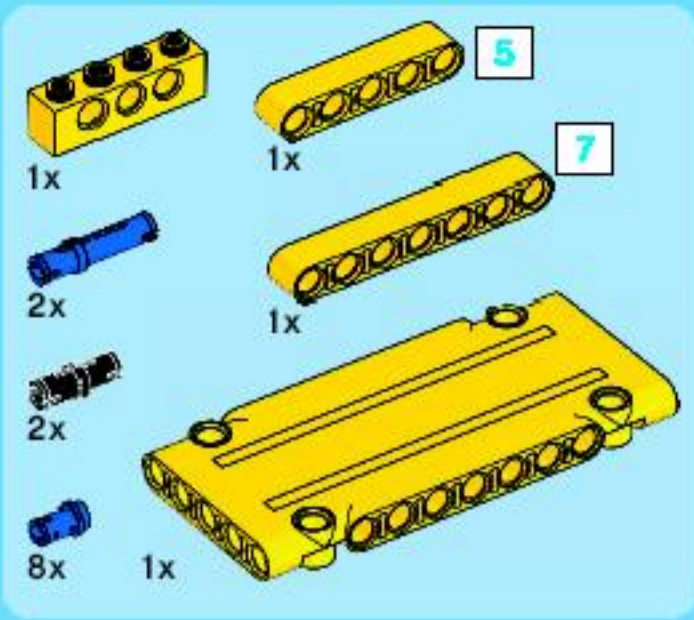

94

1

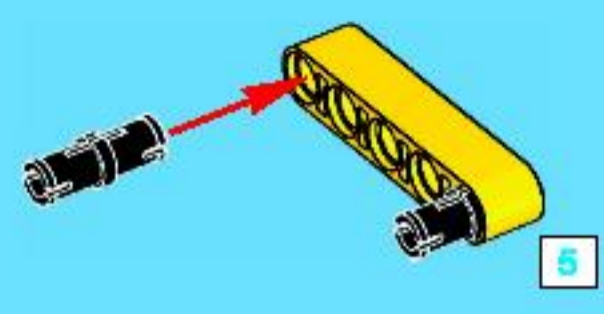

2

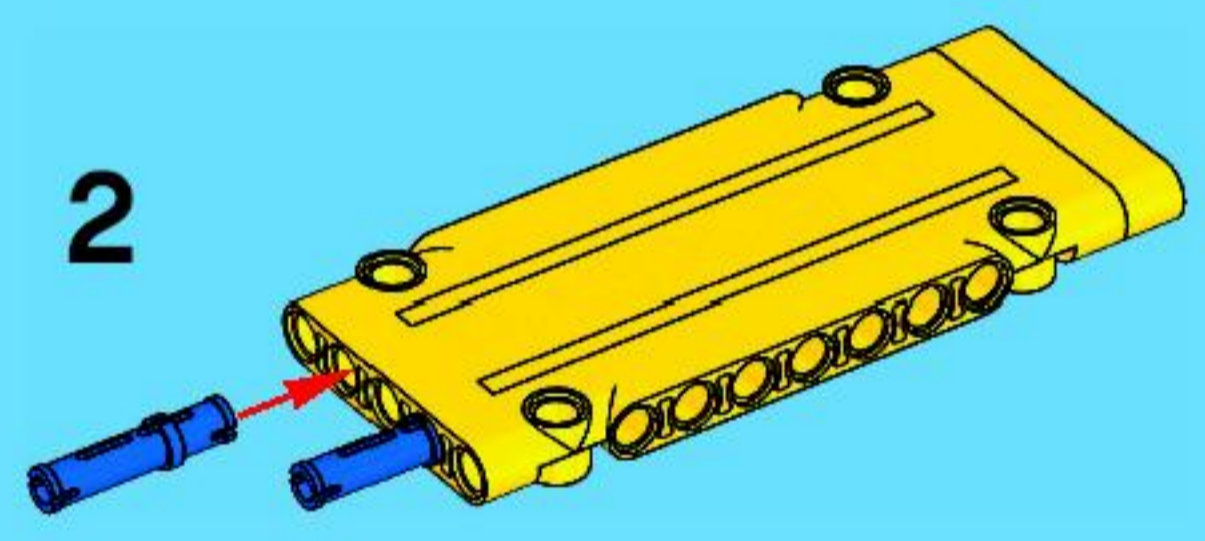

3

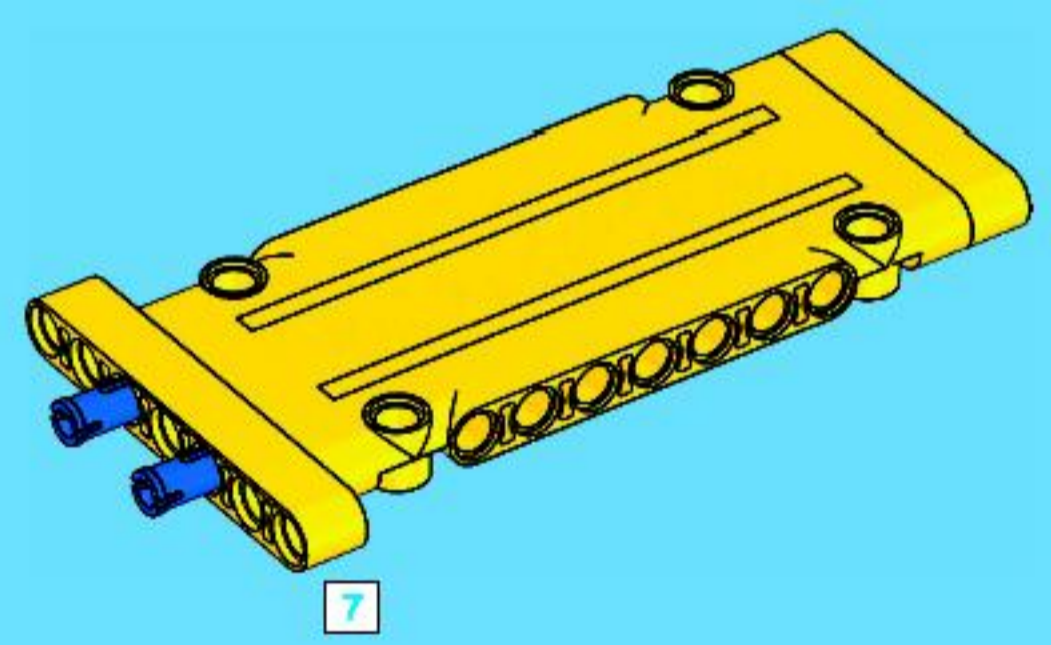

4

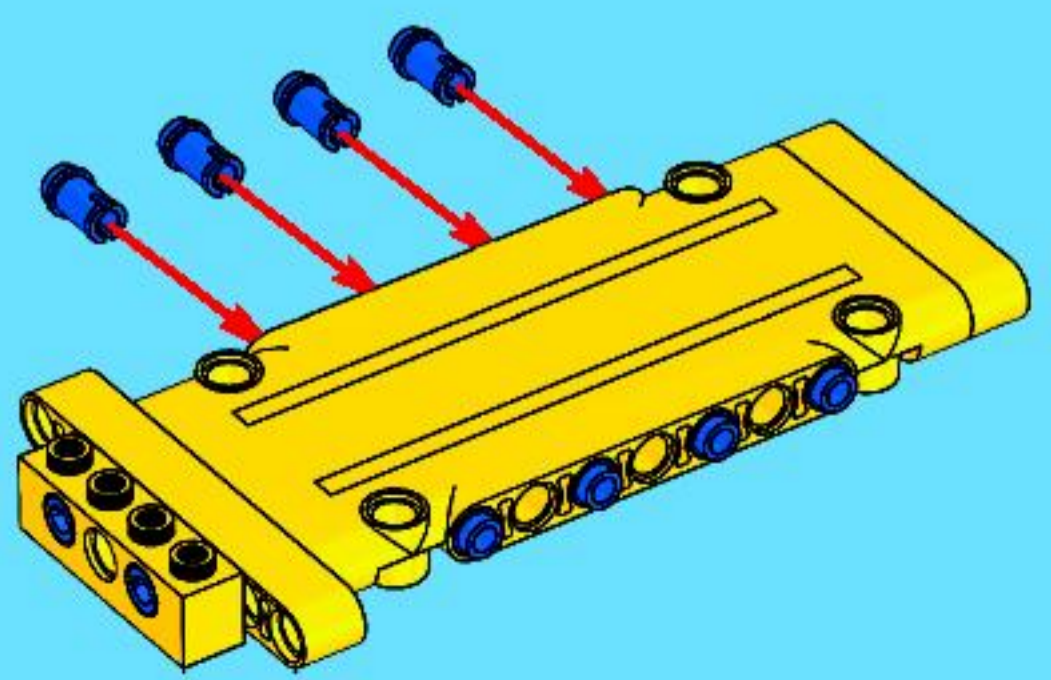

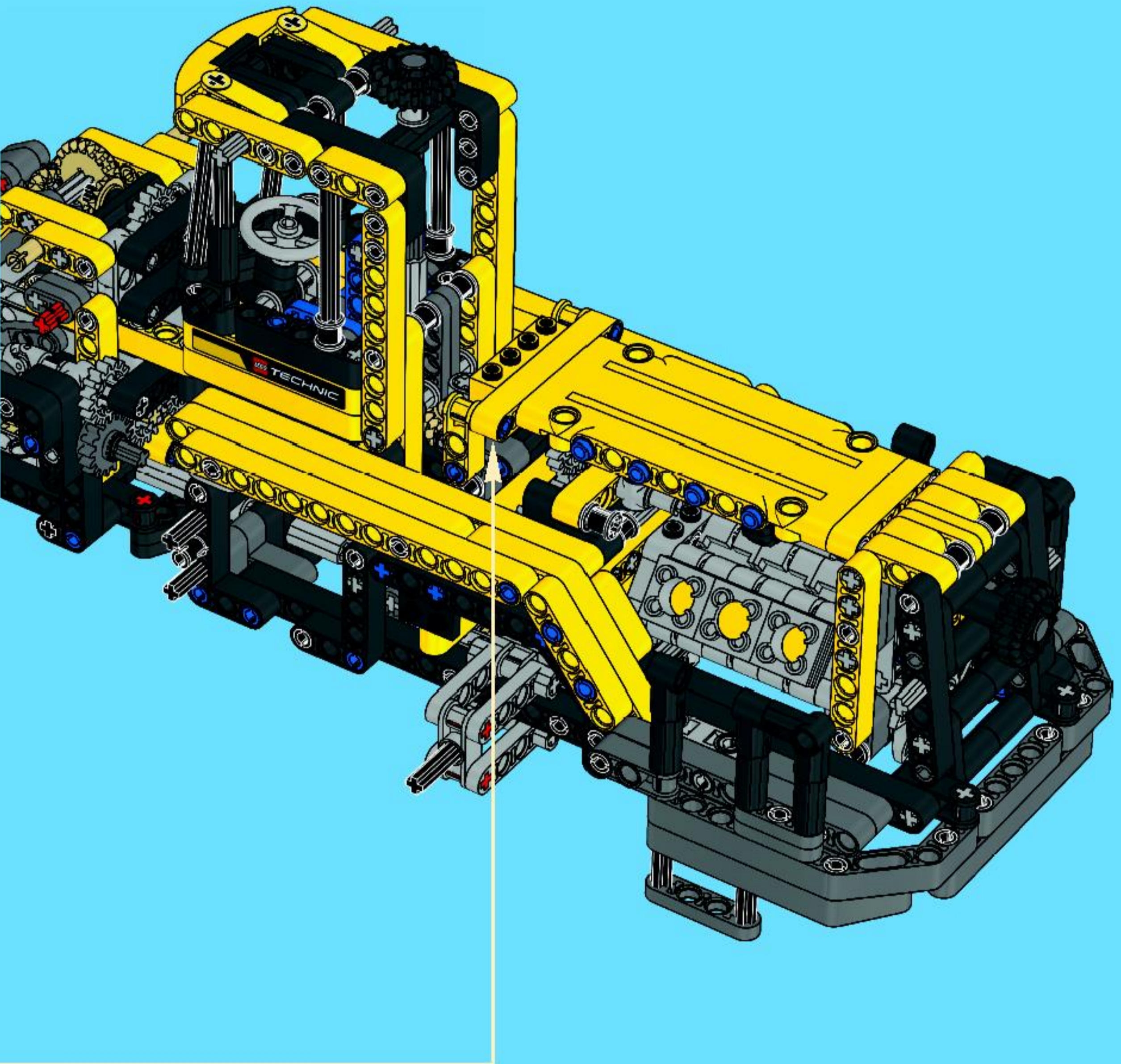



1x

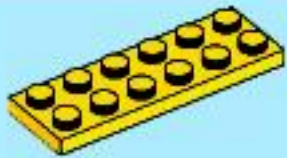

1x

1

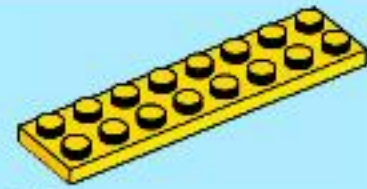
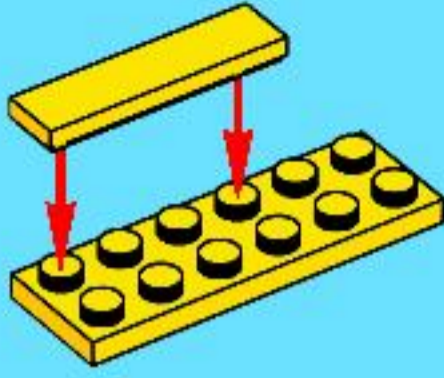

1x

4

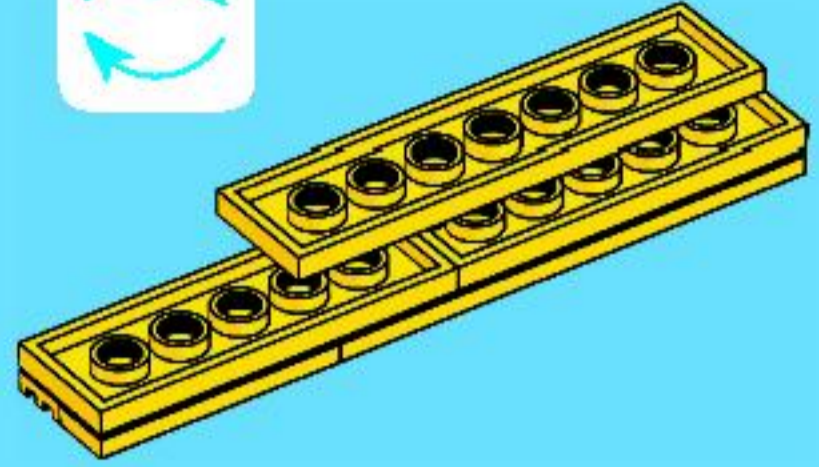

2x

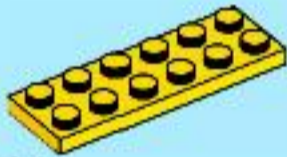

1x

2

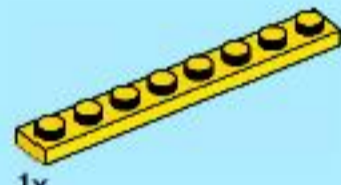
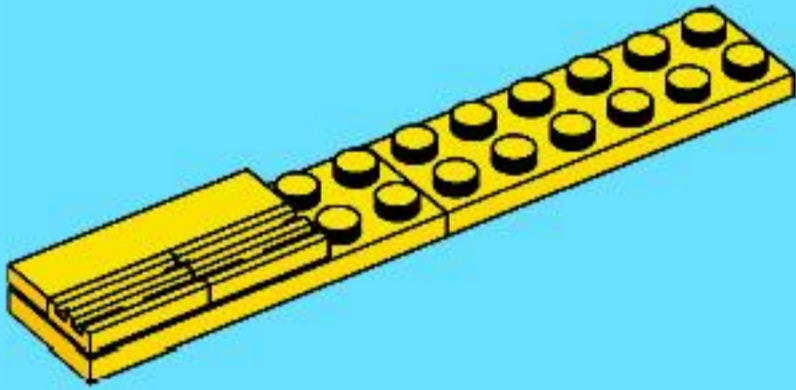

1x

5

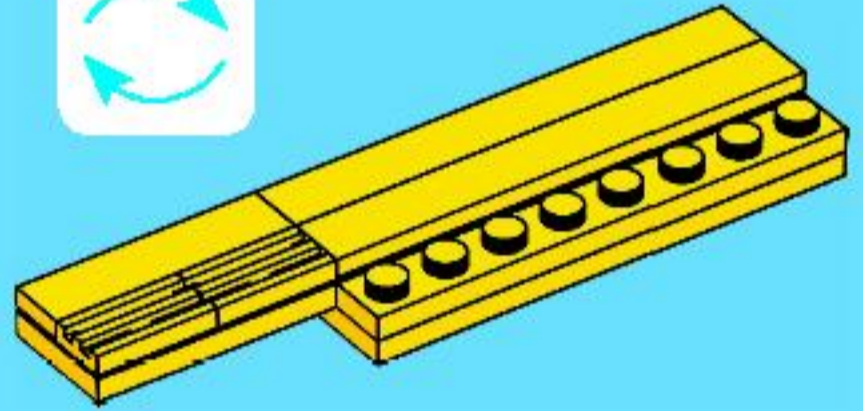

2x

3

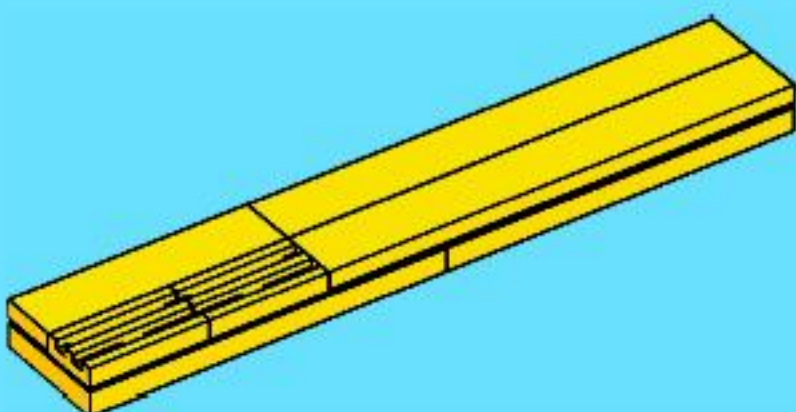

1x

6

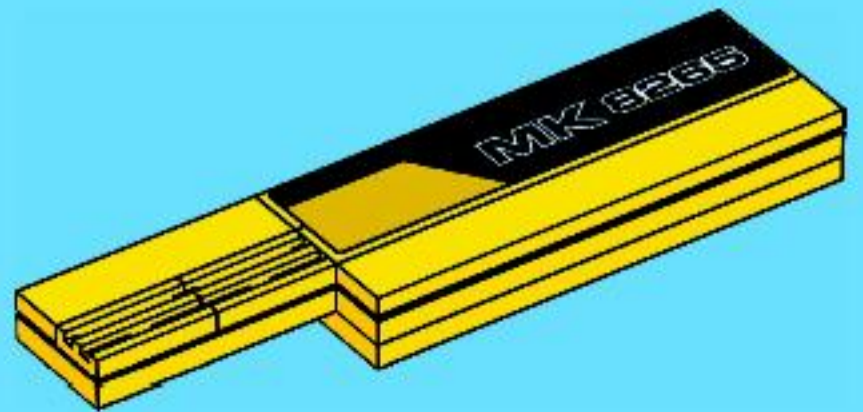

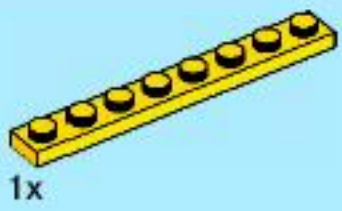

1x

7

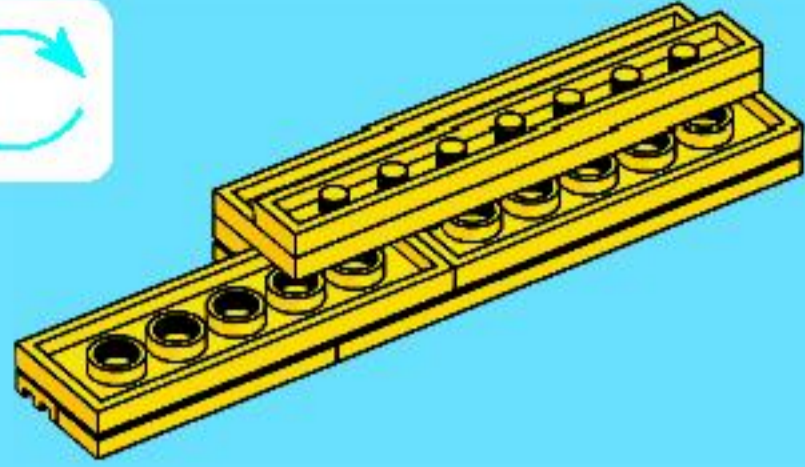

95

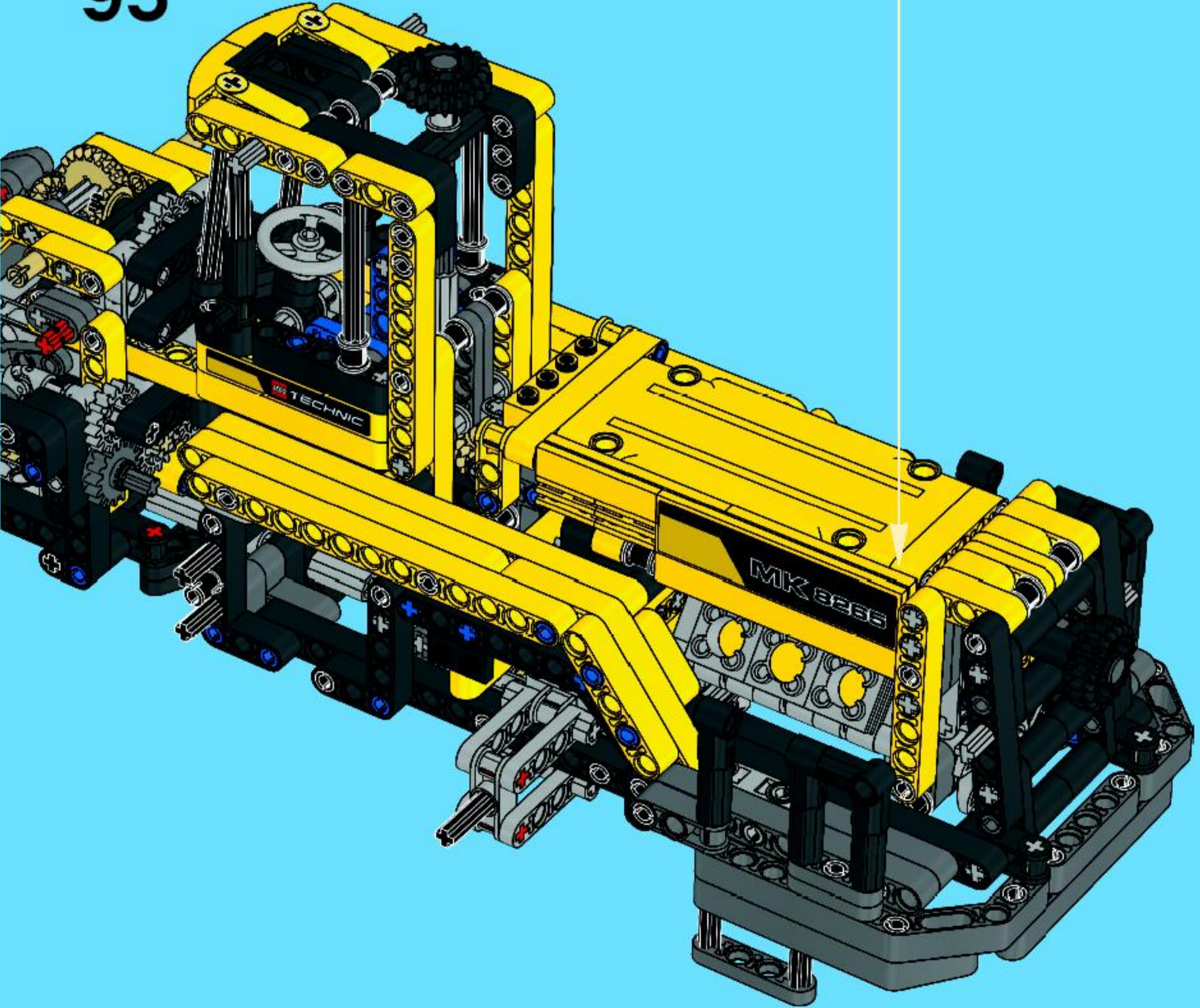



1x

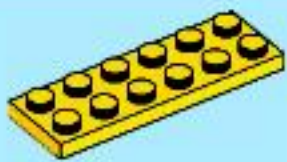

1x

1

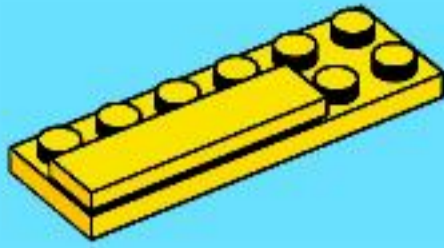

2x



1x

2

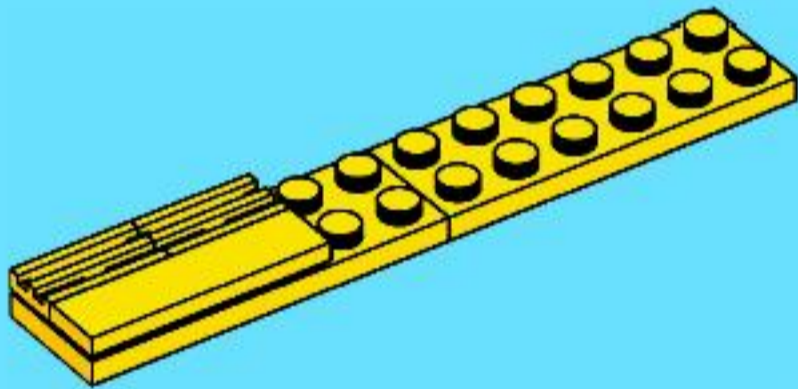

2x

3

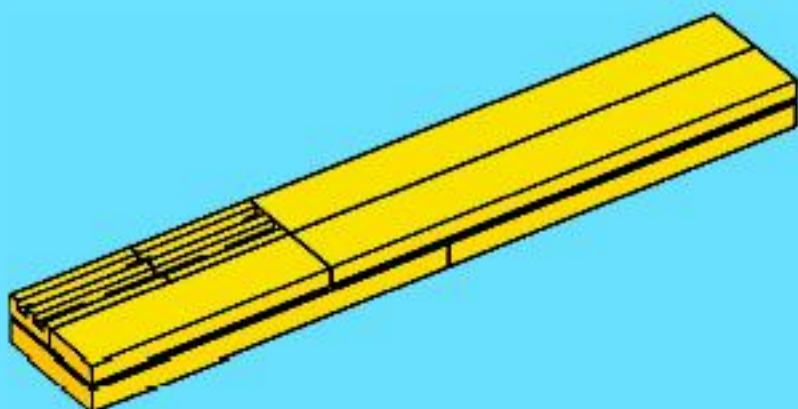

1x

4

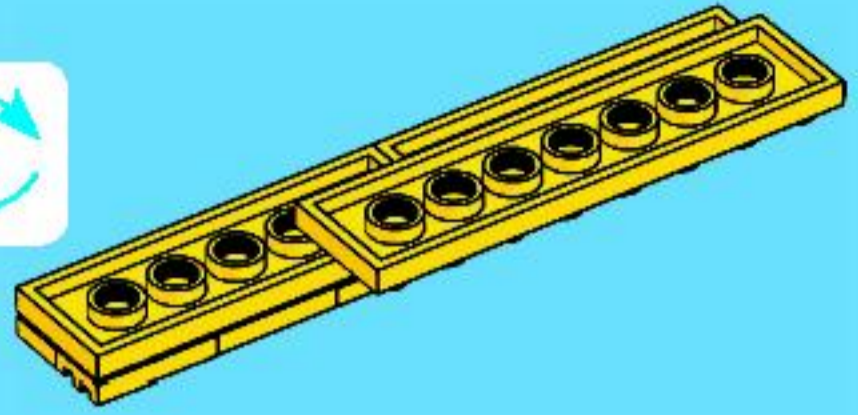

1x

5

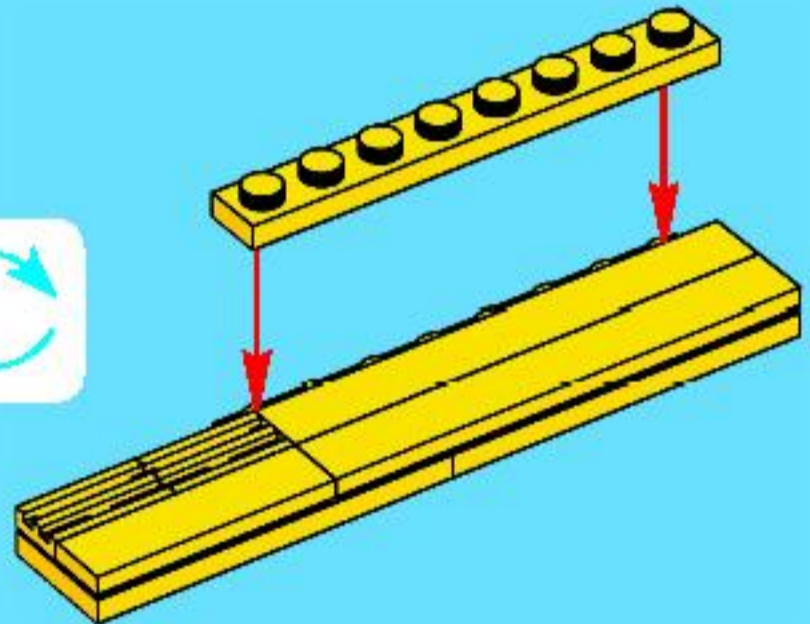

1x

6

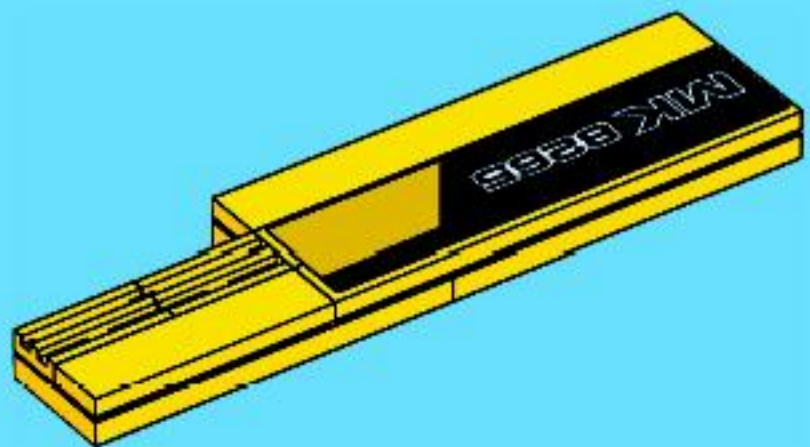



1x

7

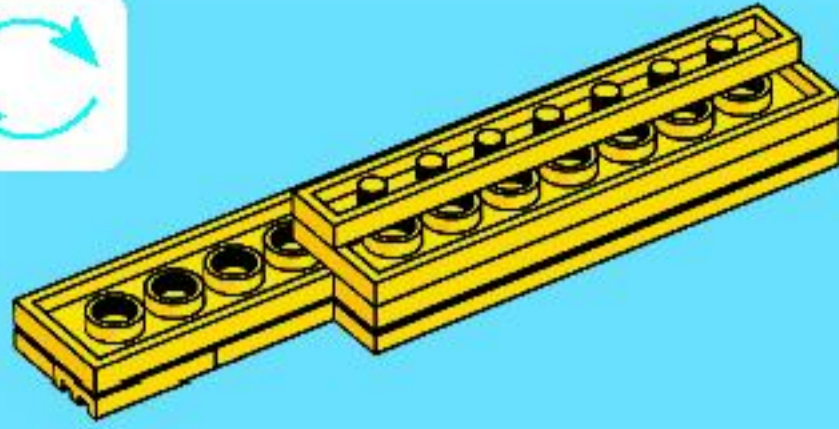

96

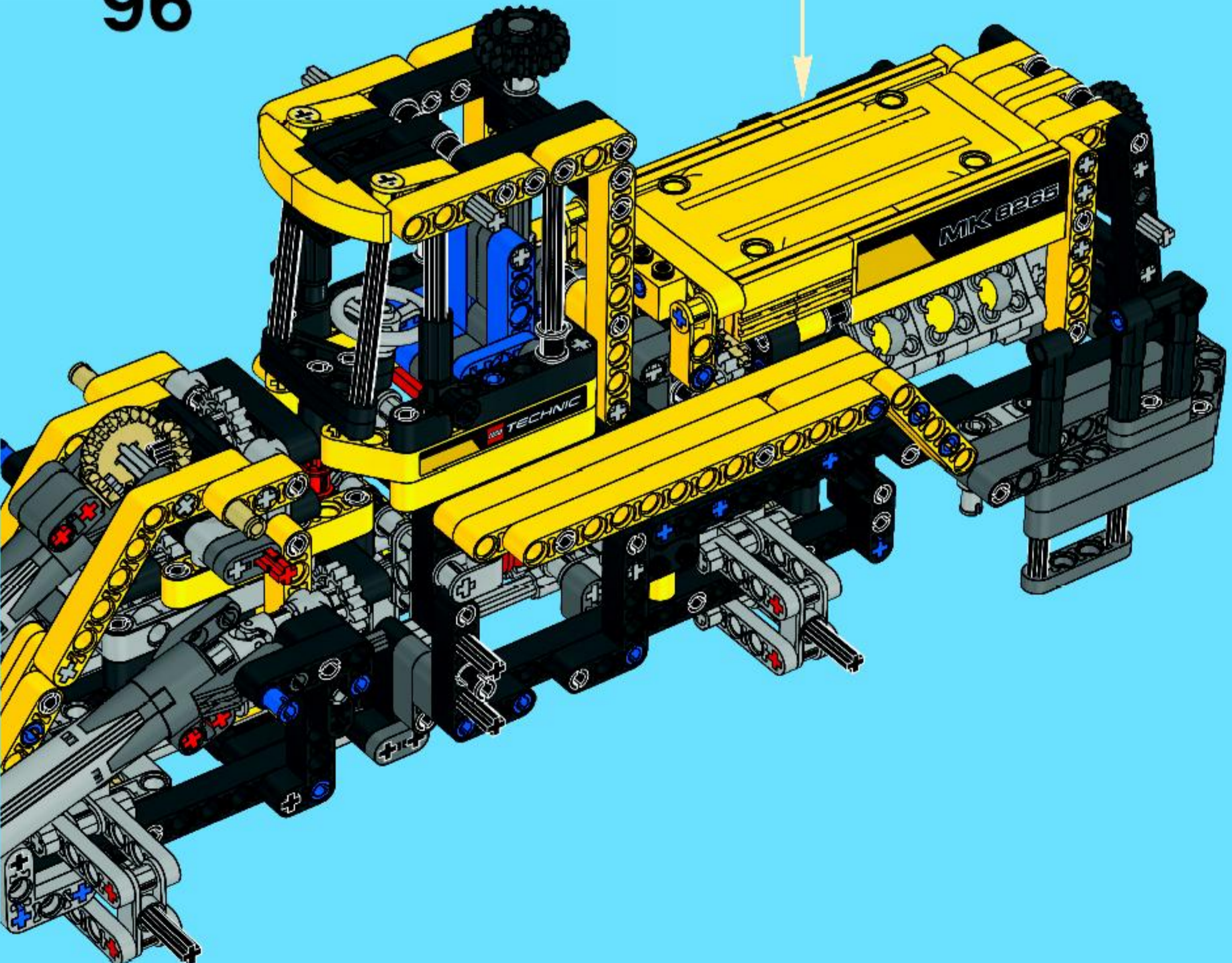

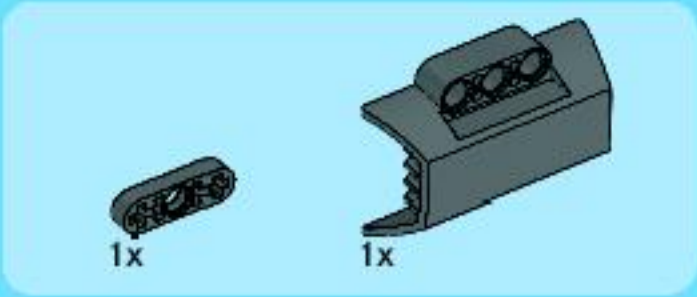

97

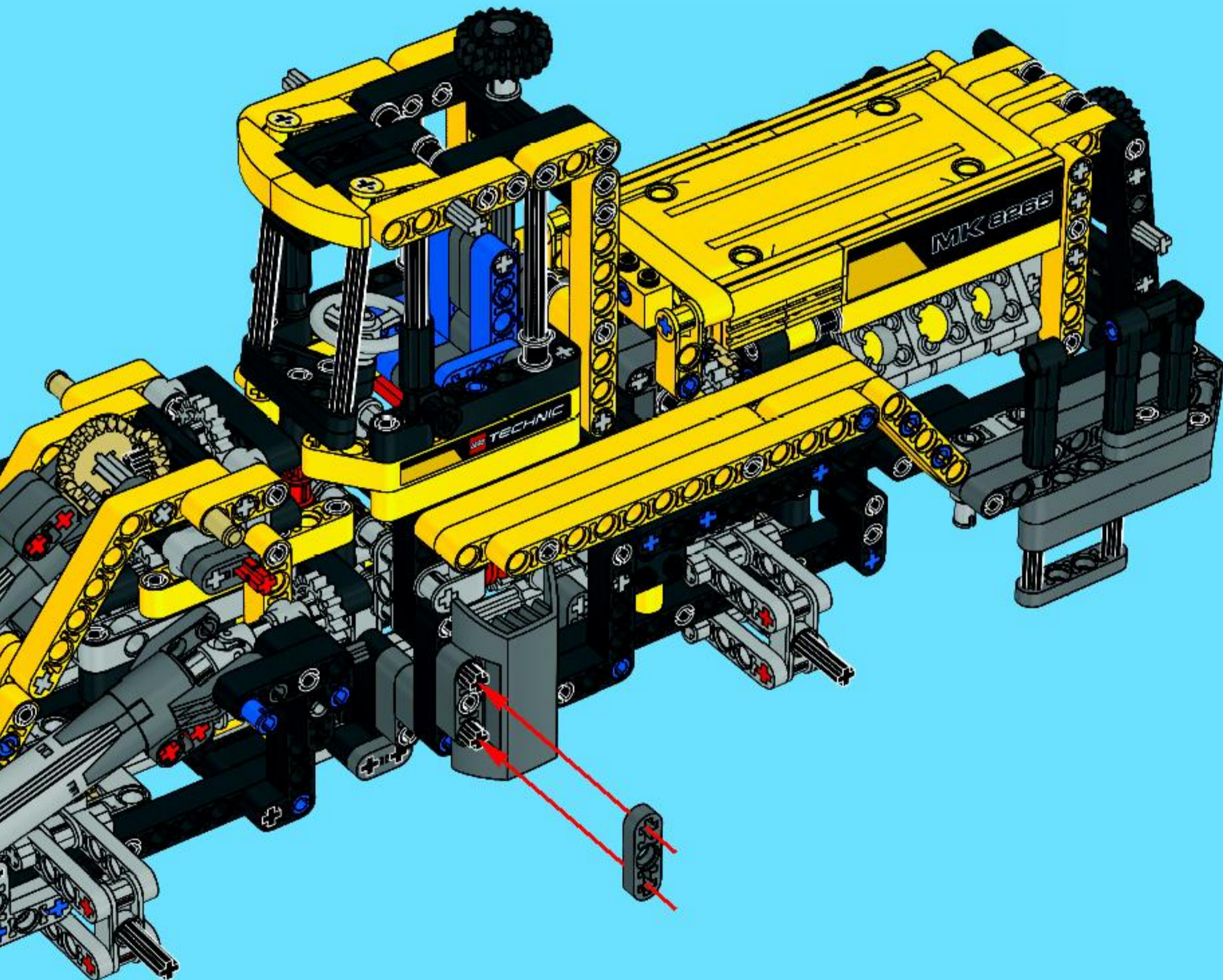



98

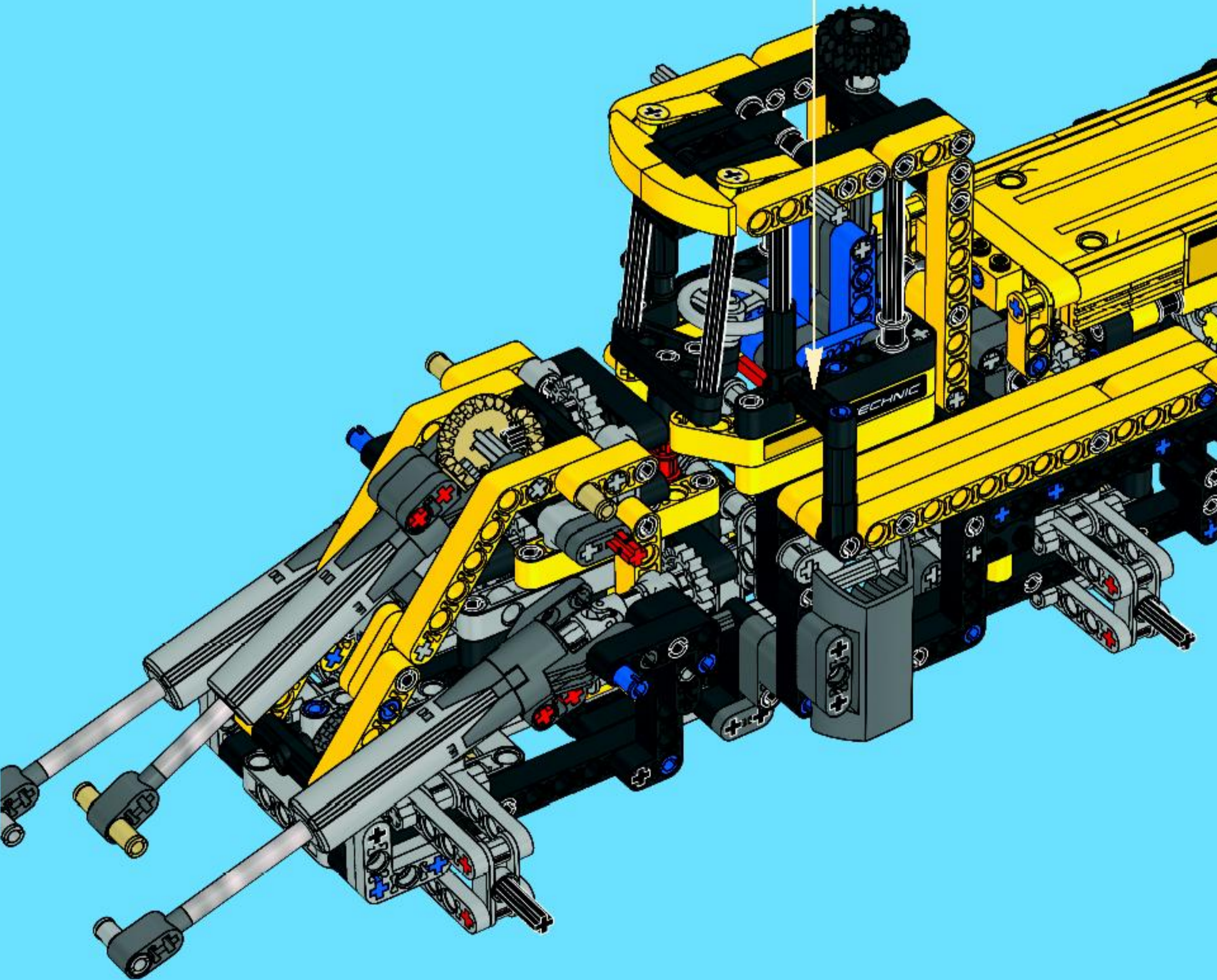
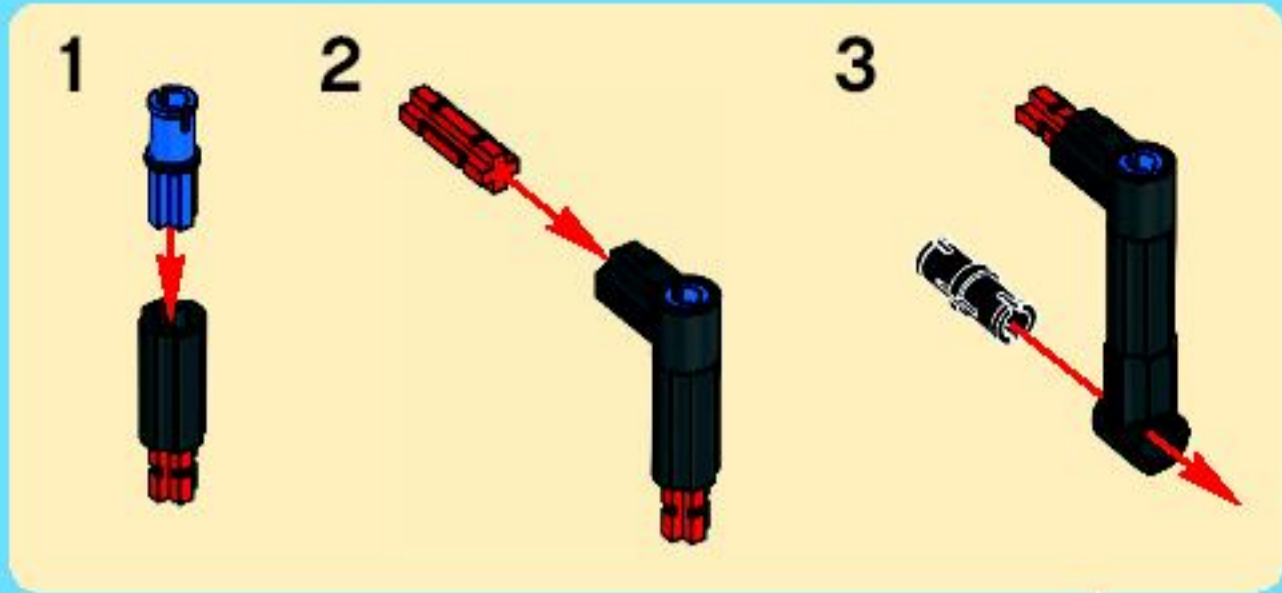

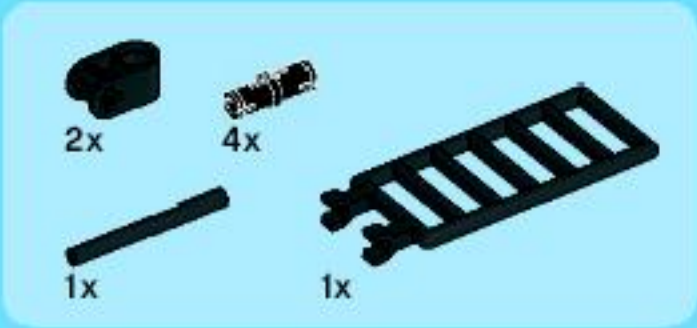

99

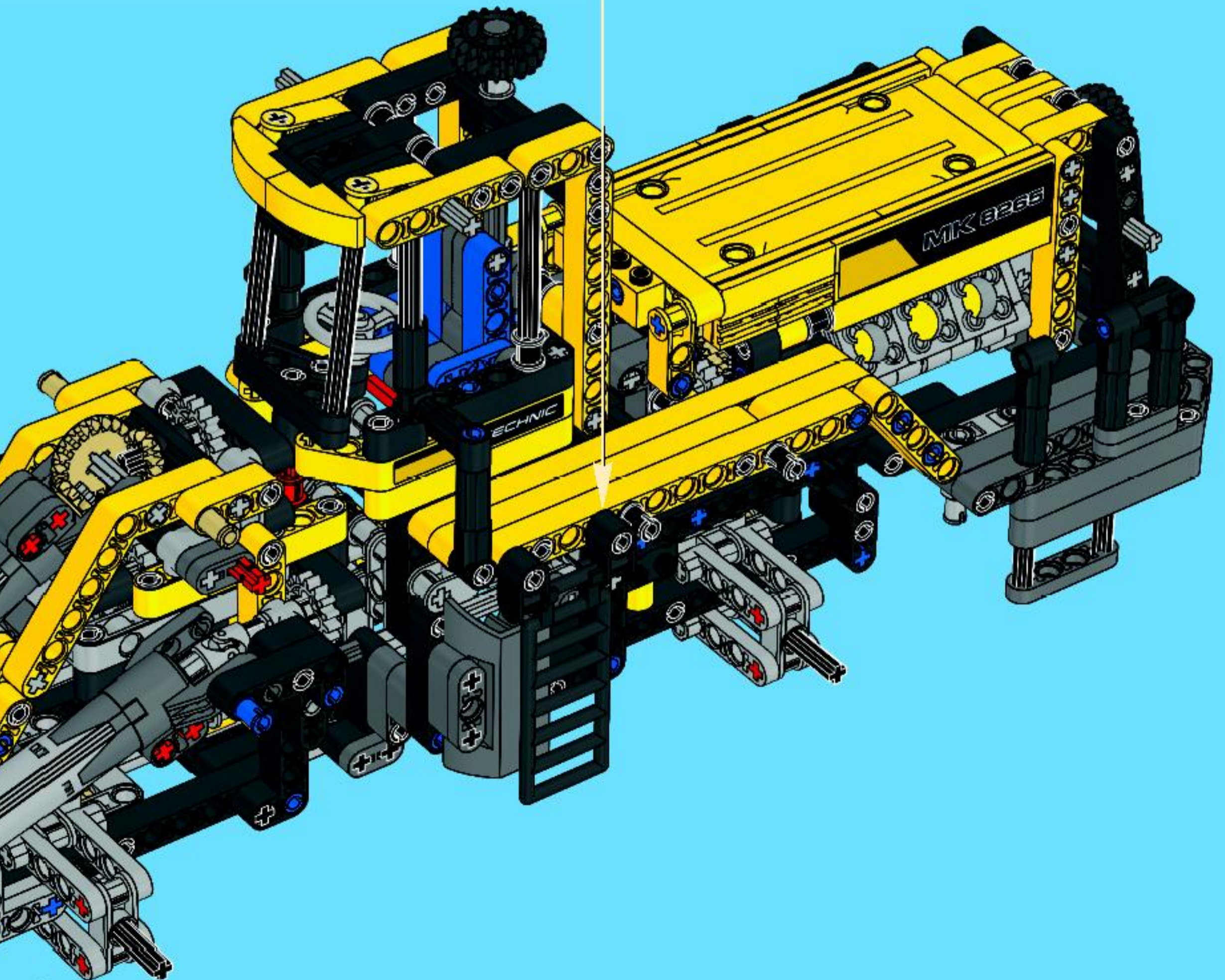
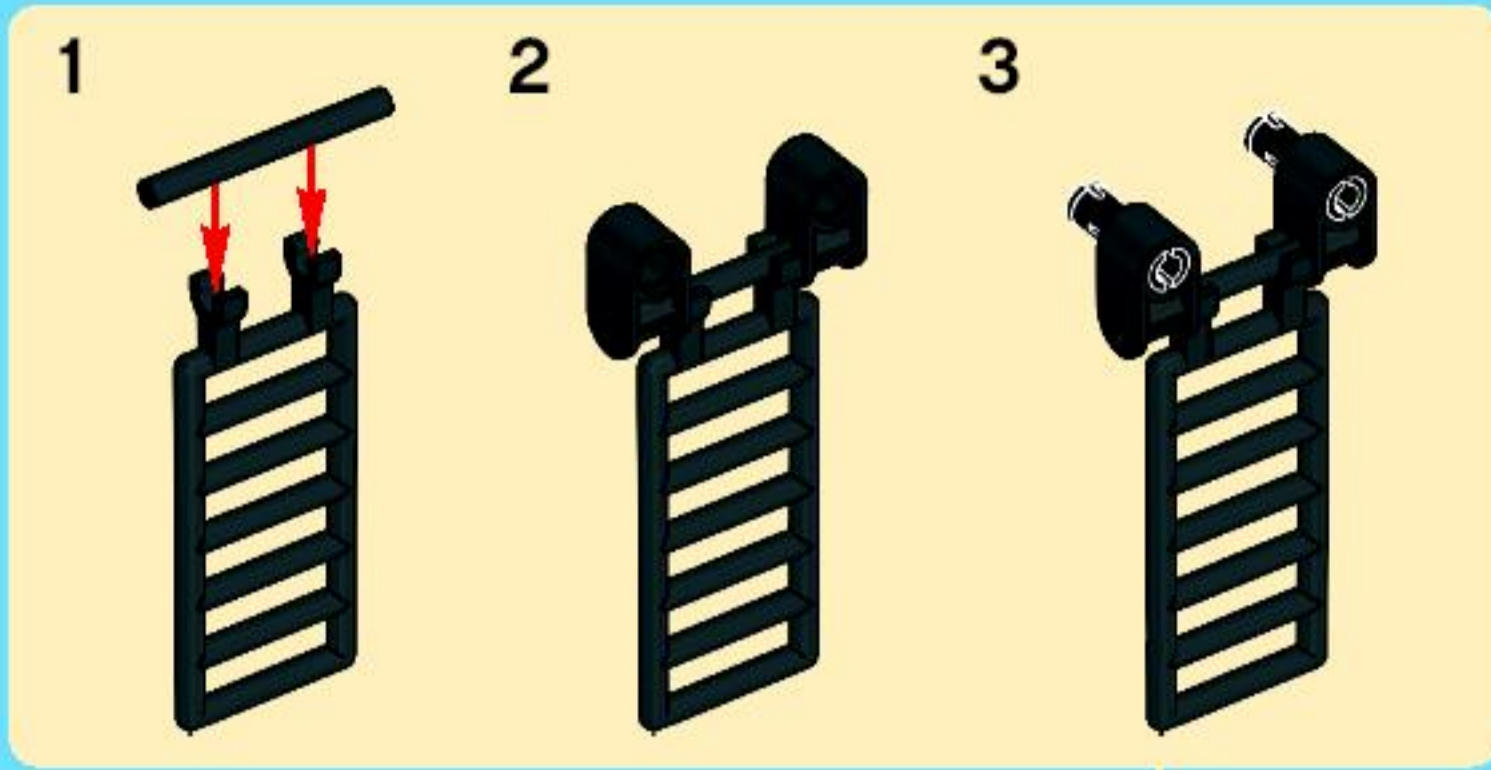

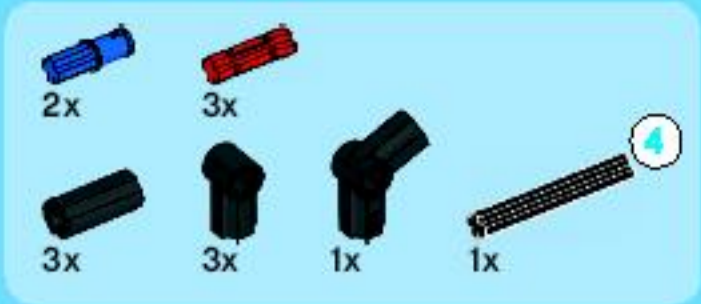

100

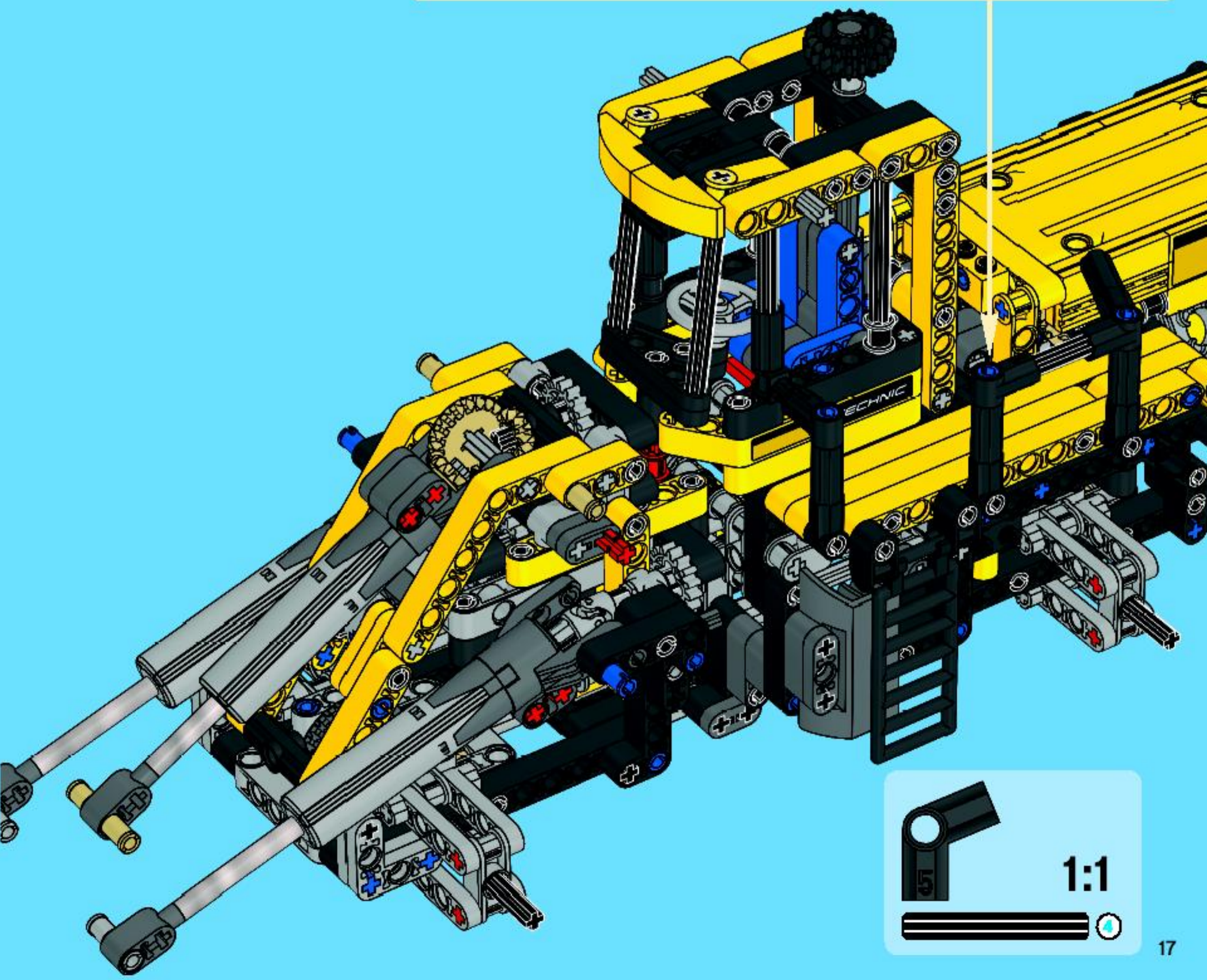
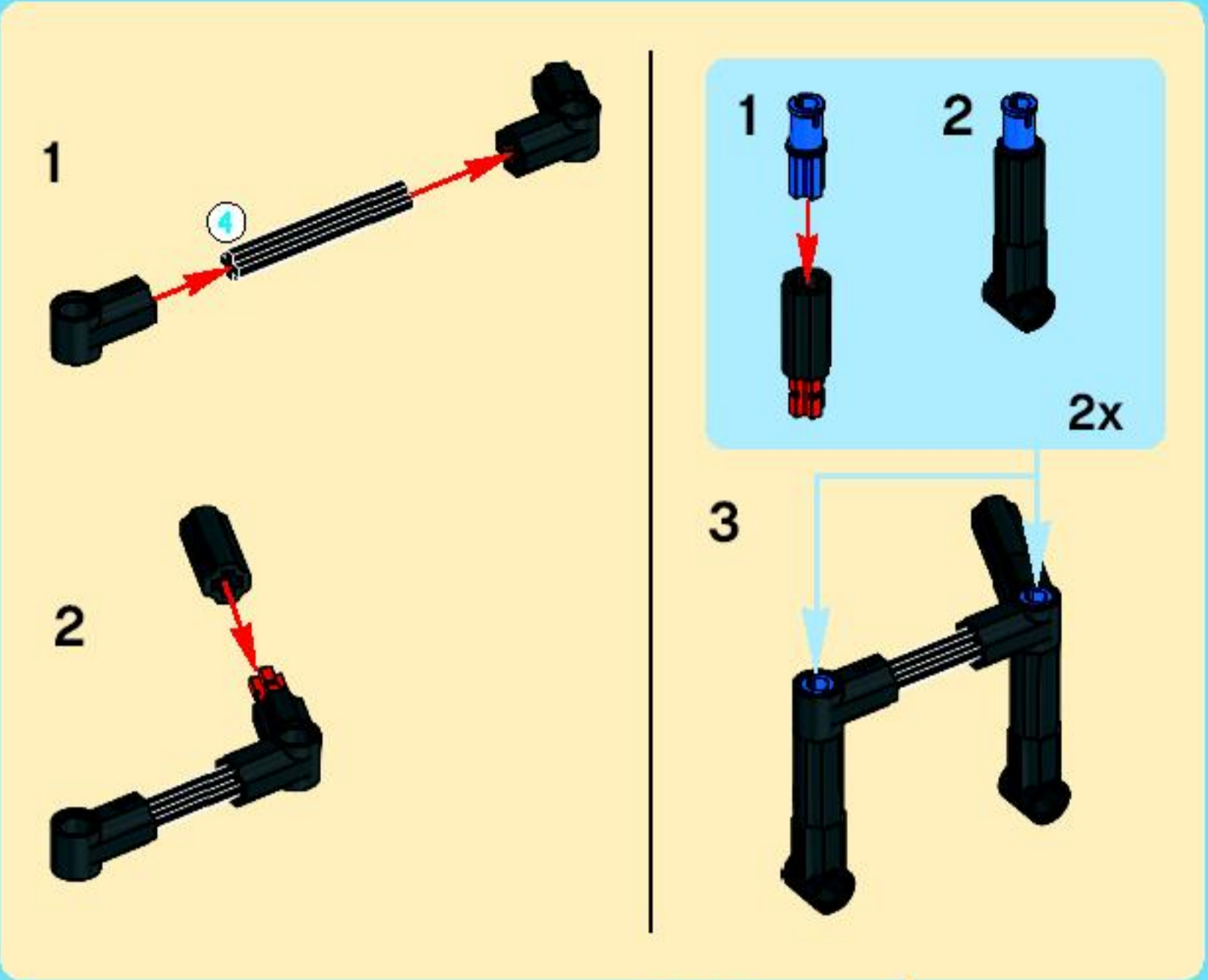

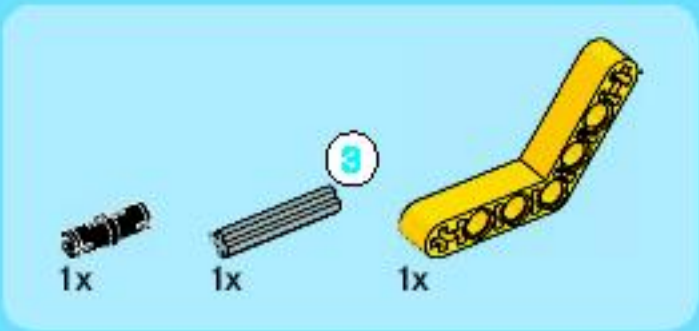

1

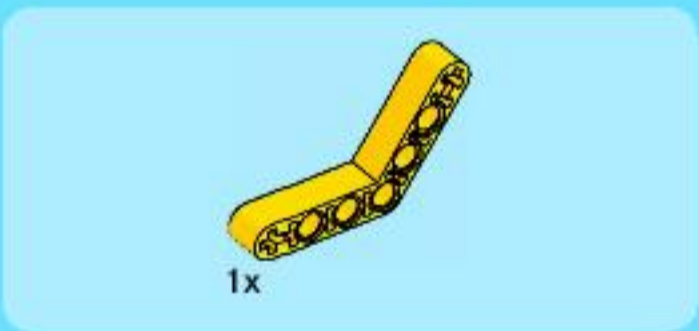
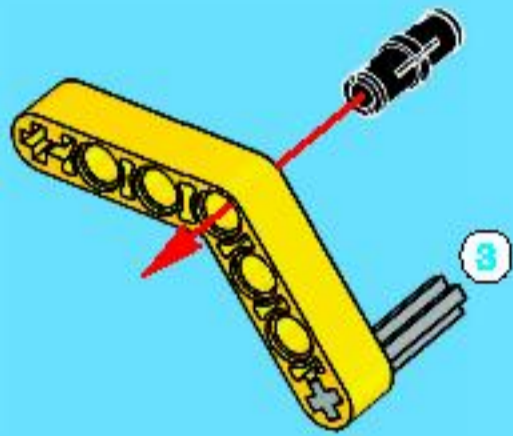

2

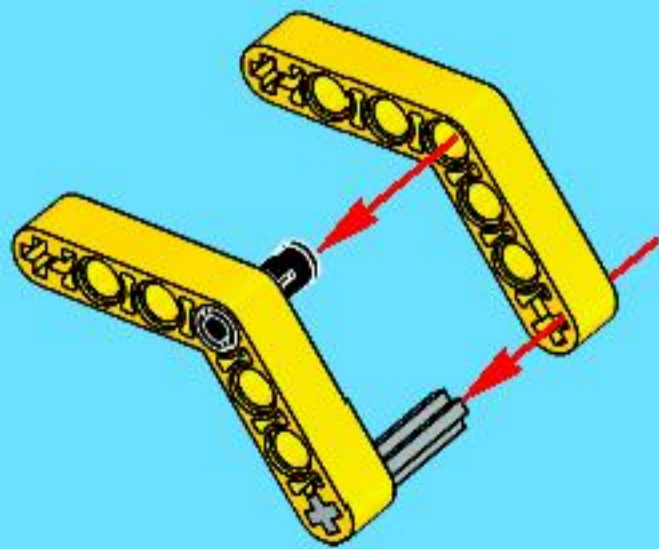

3

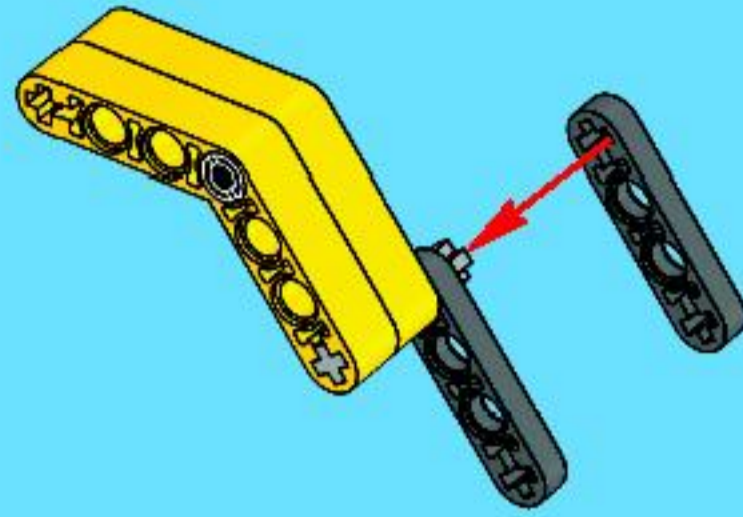

4

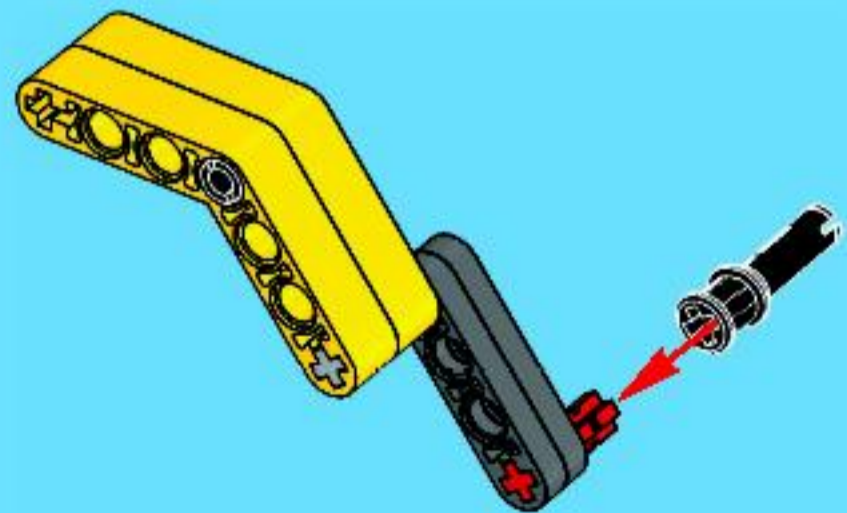

101

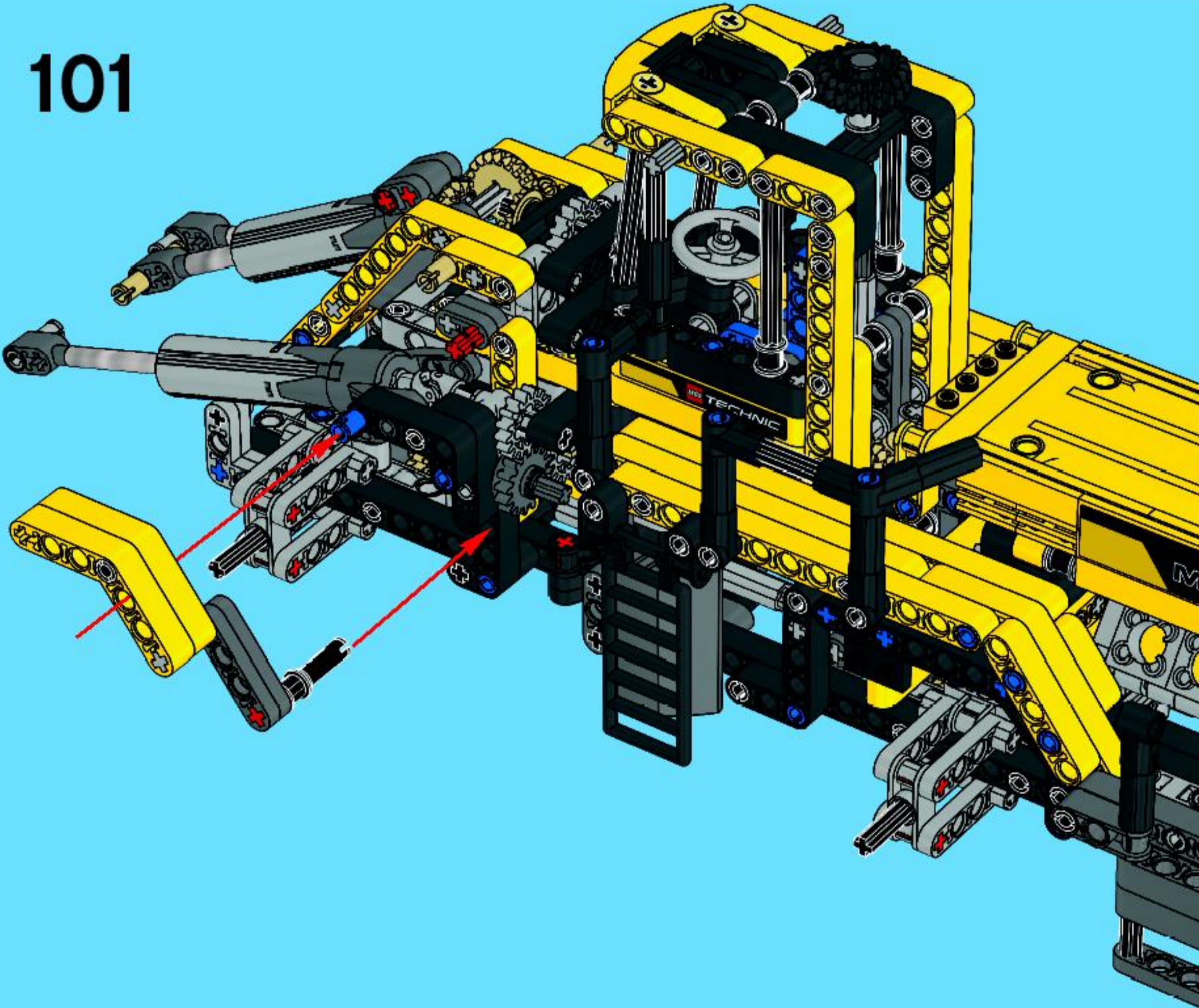



102

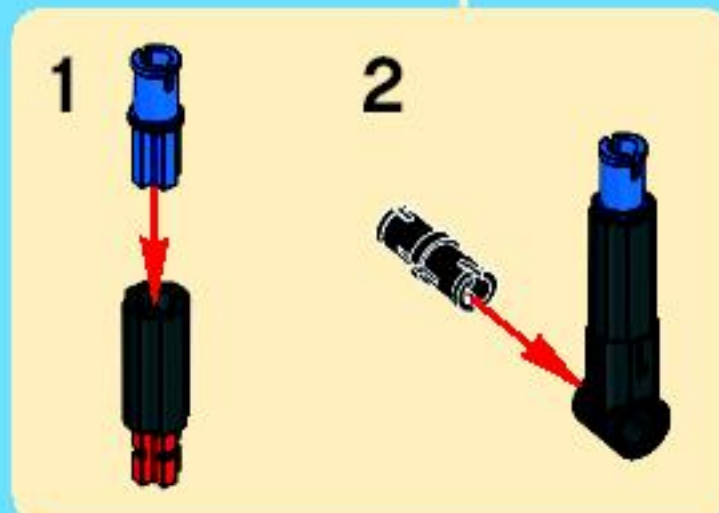
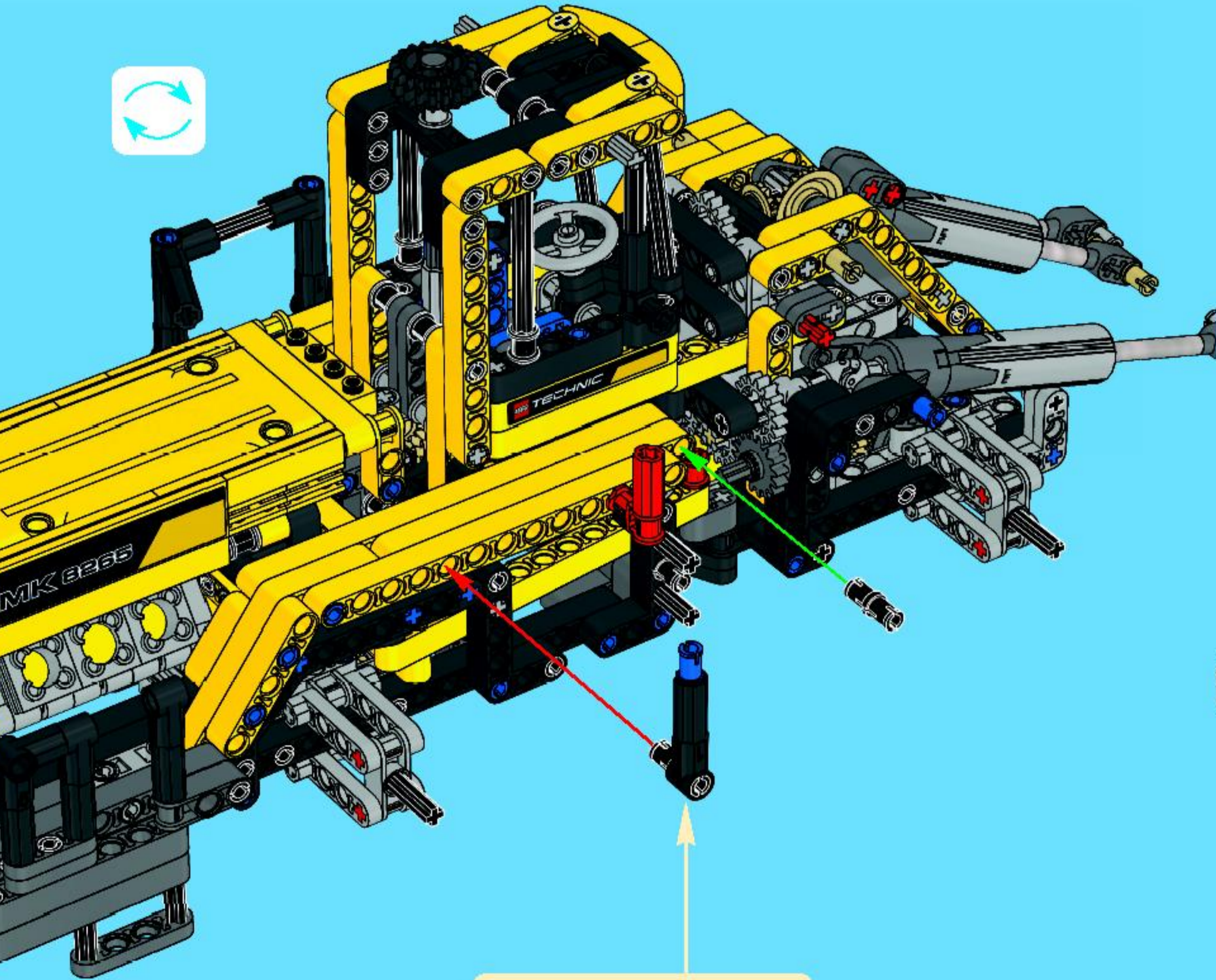

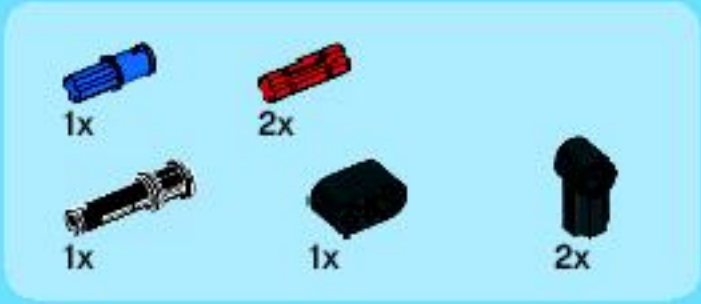

103

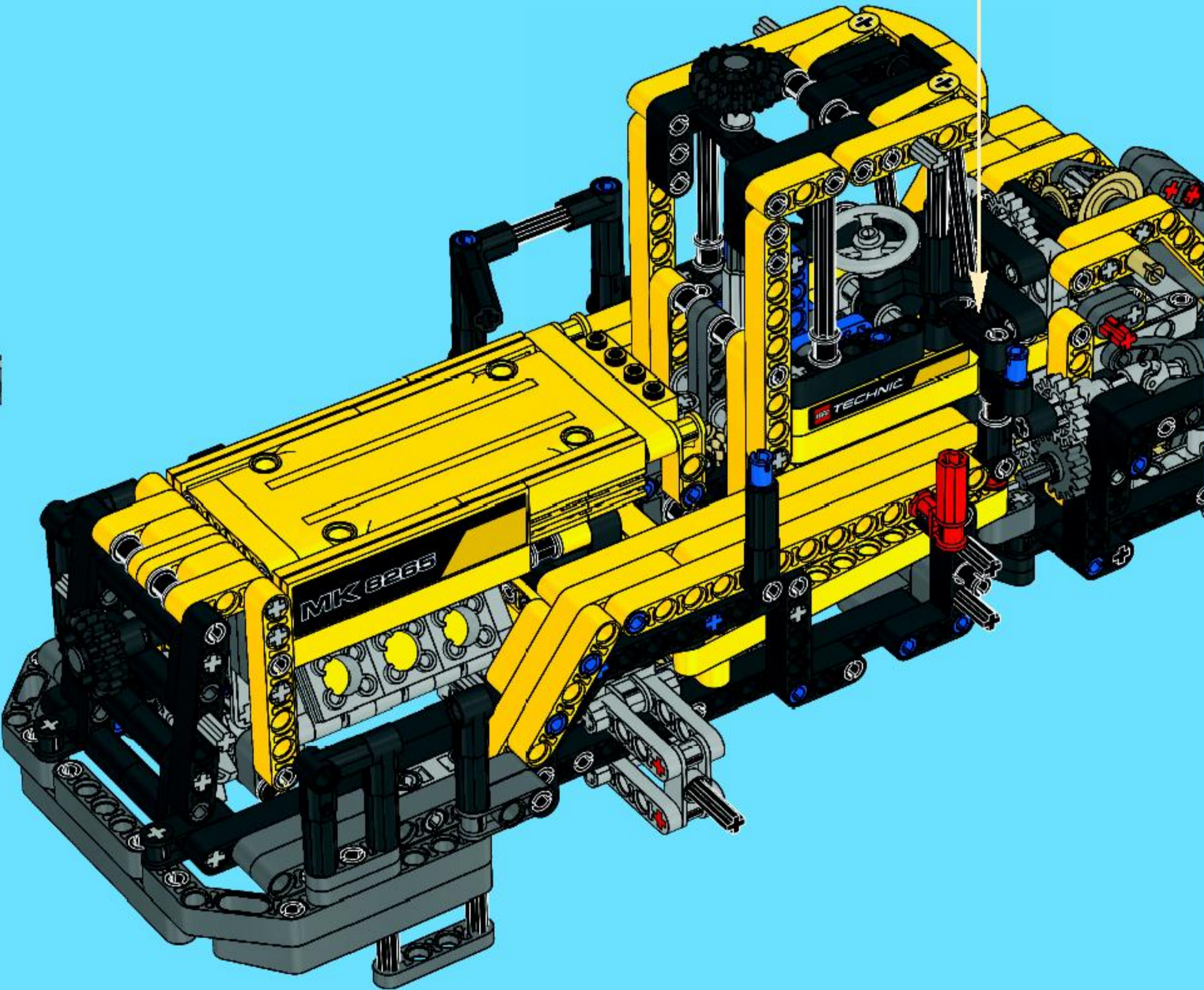
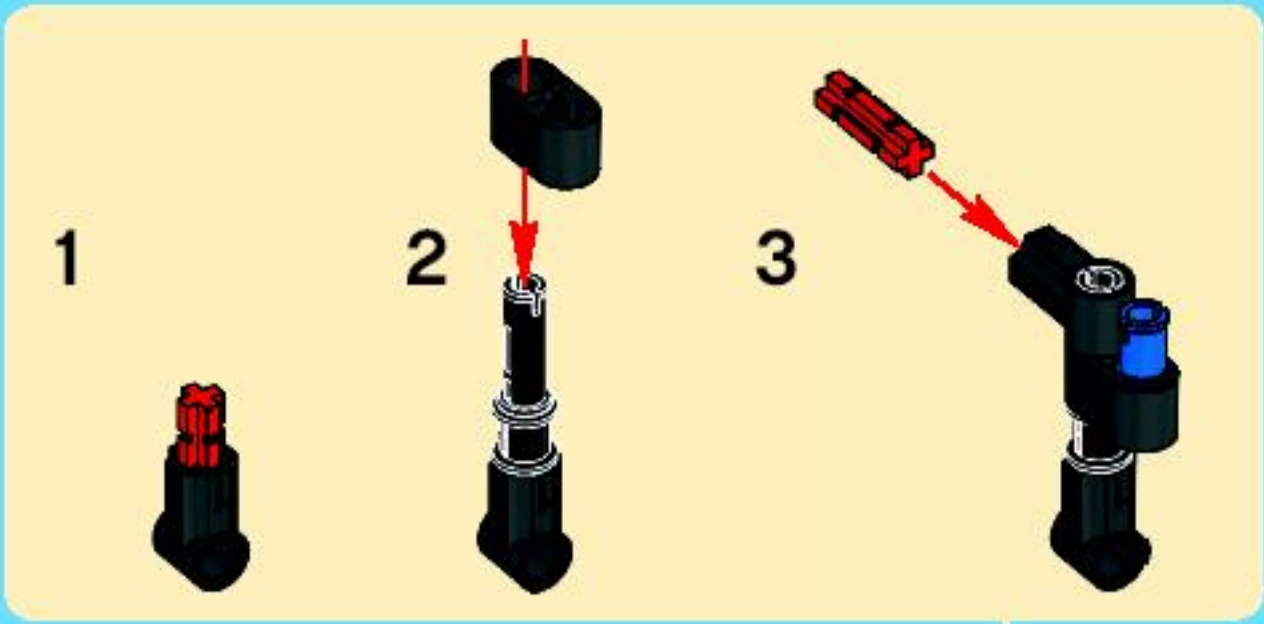

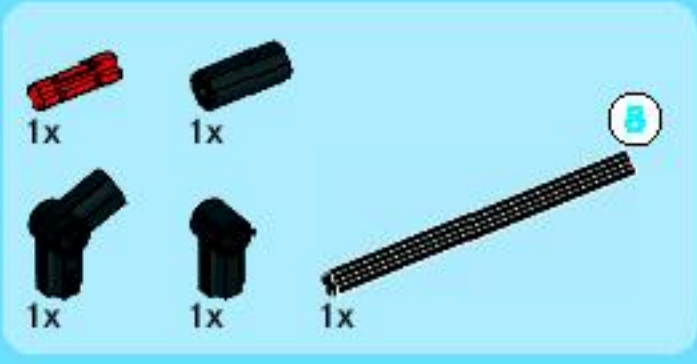

104

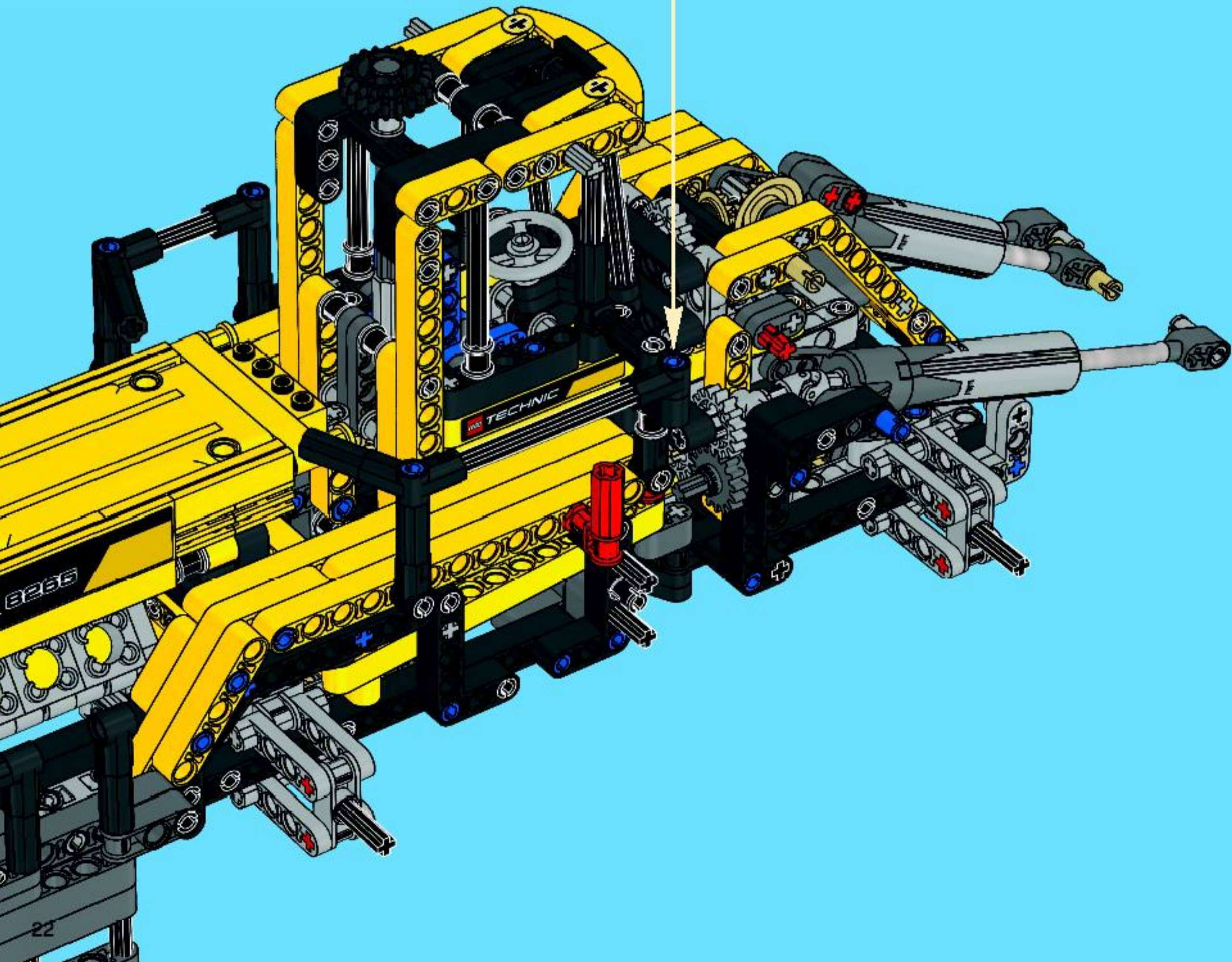
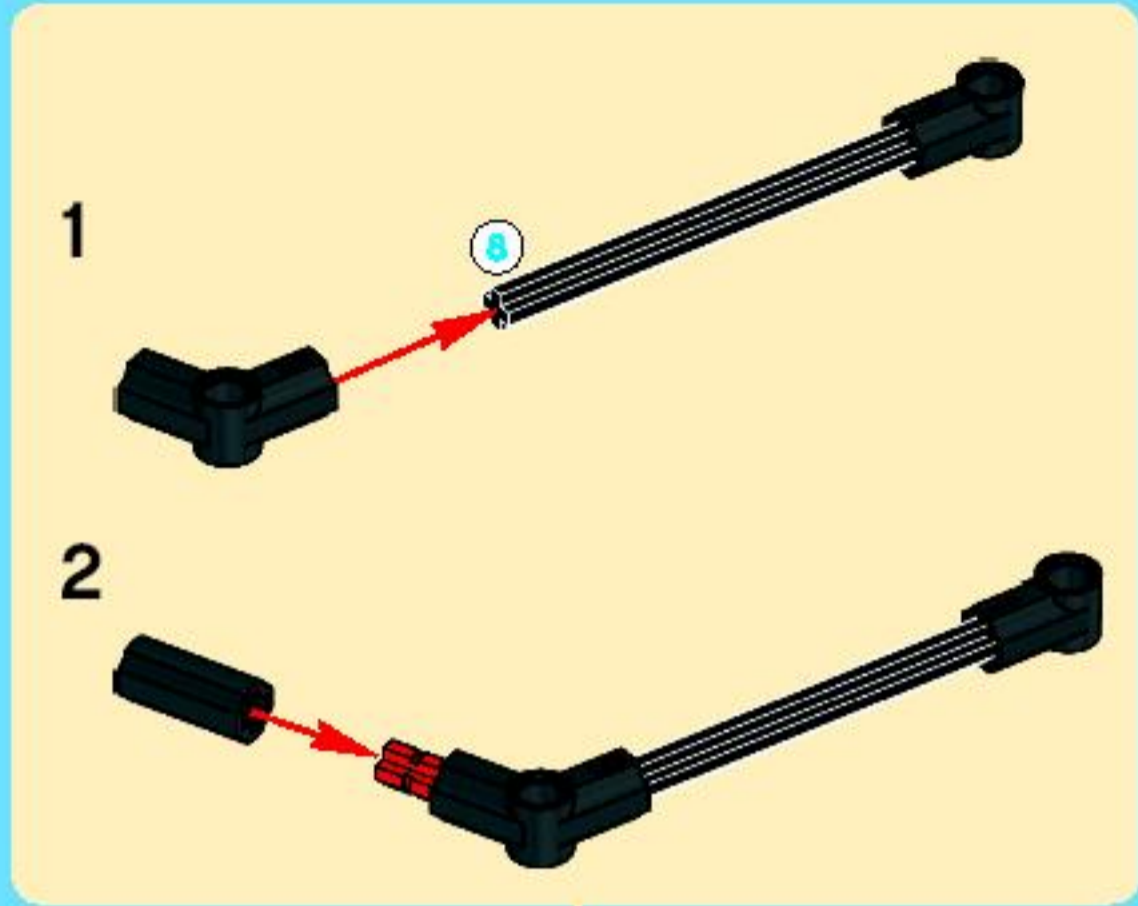

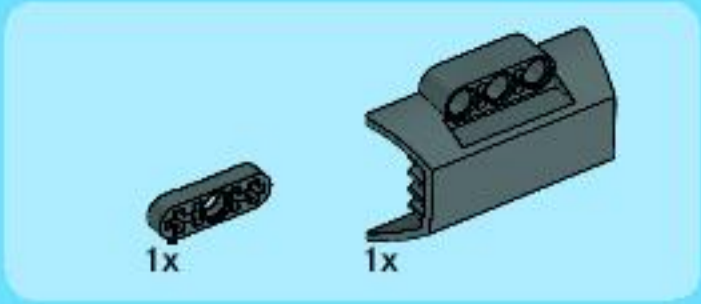

105

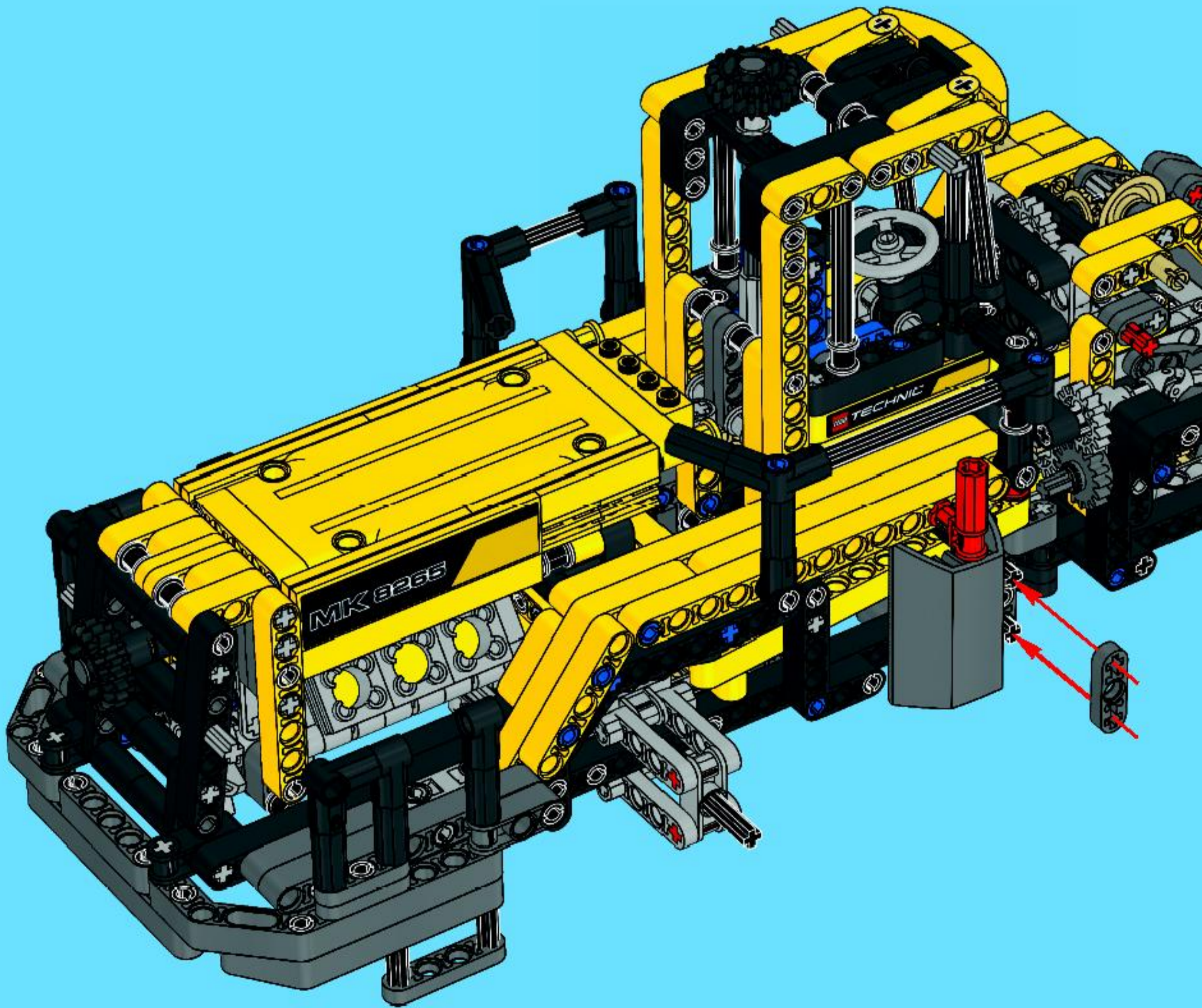

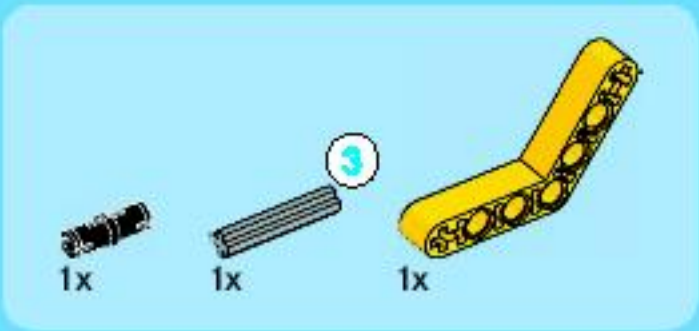

1

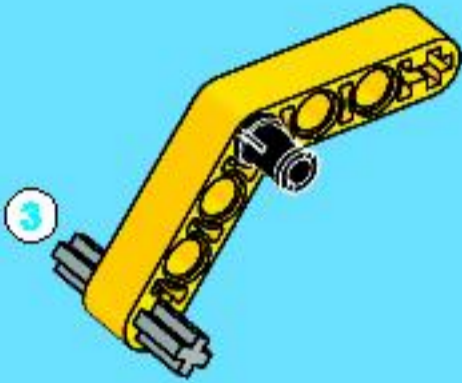

2

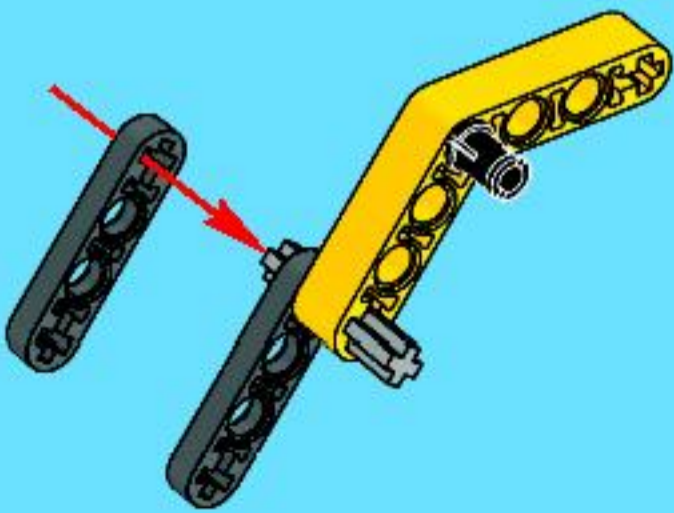

3

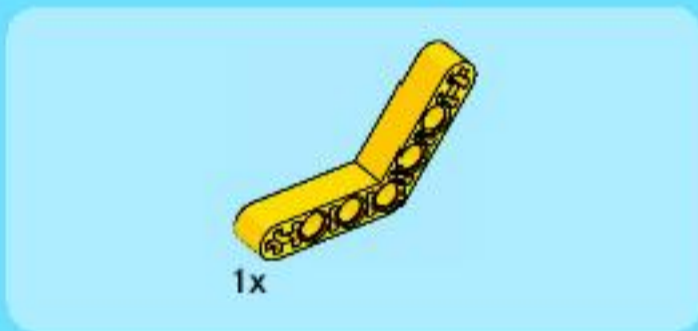
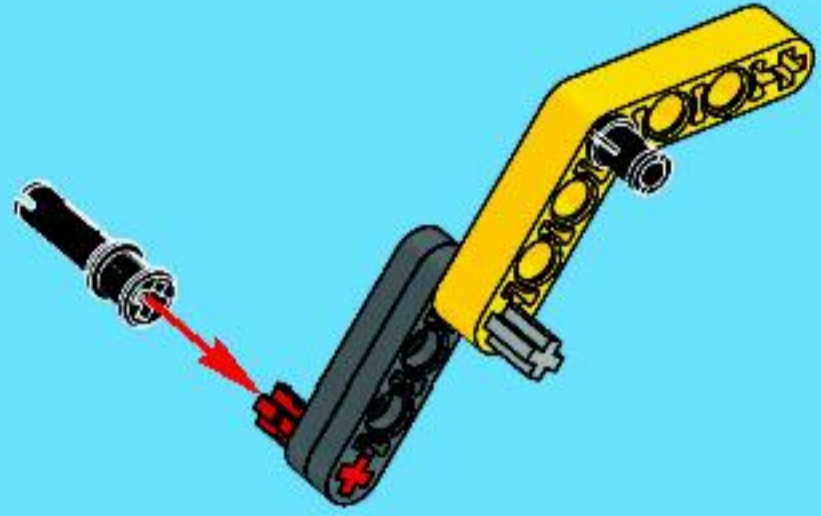

4

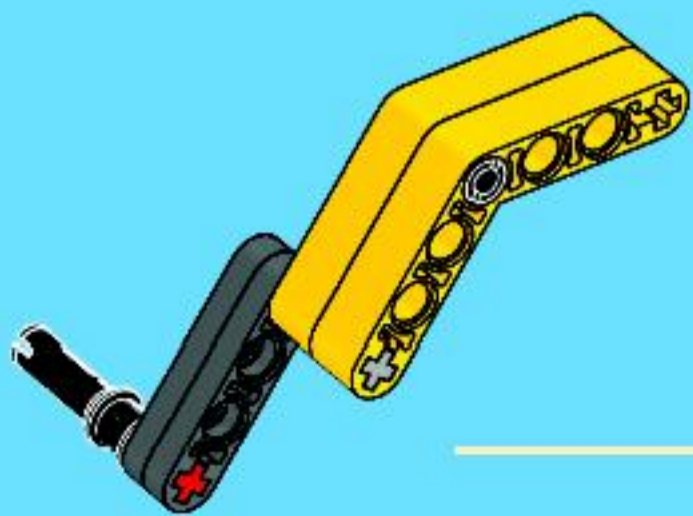

106

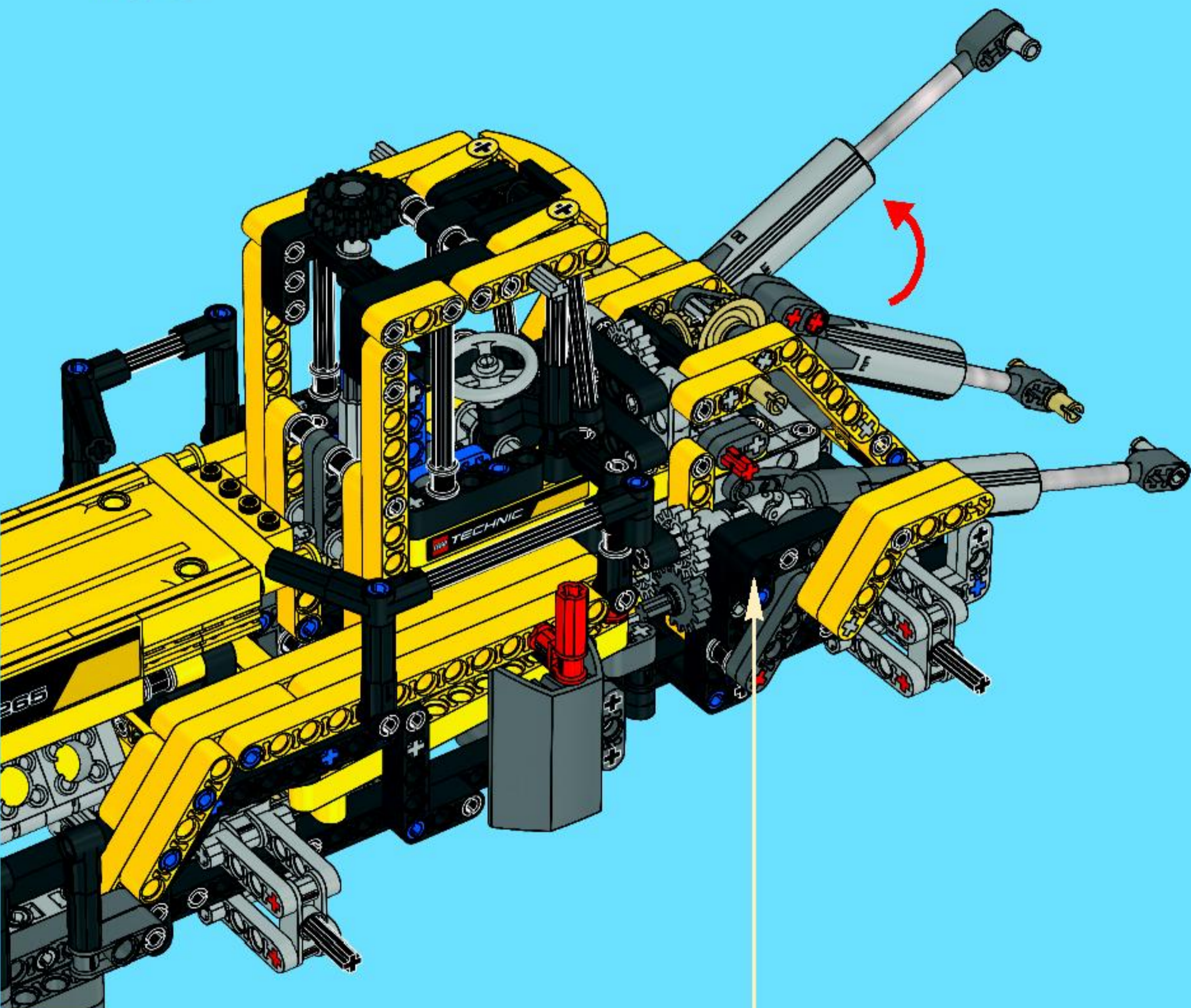

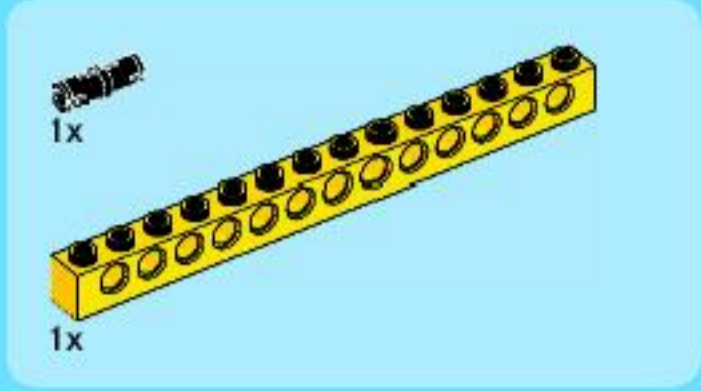
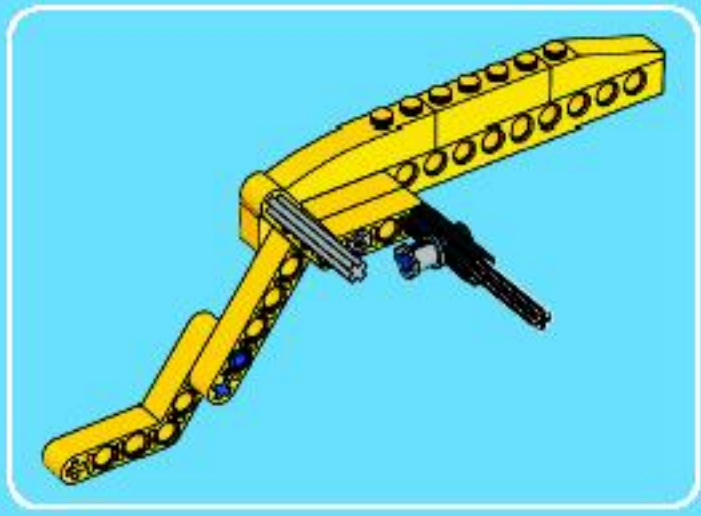

1

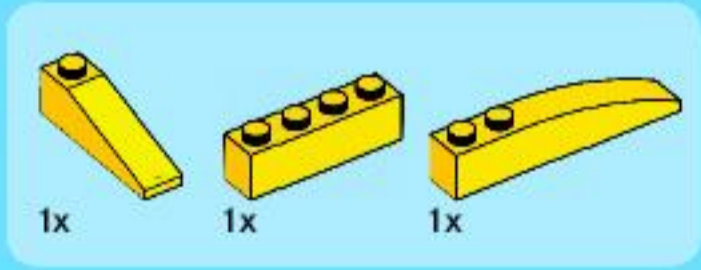
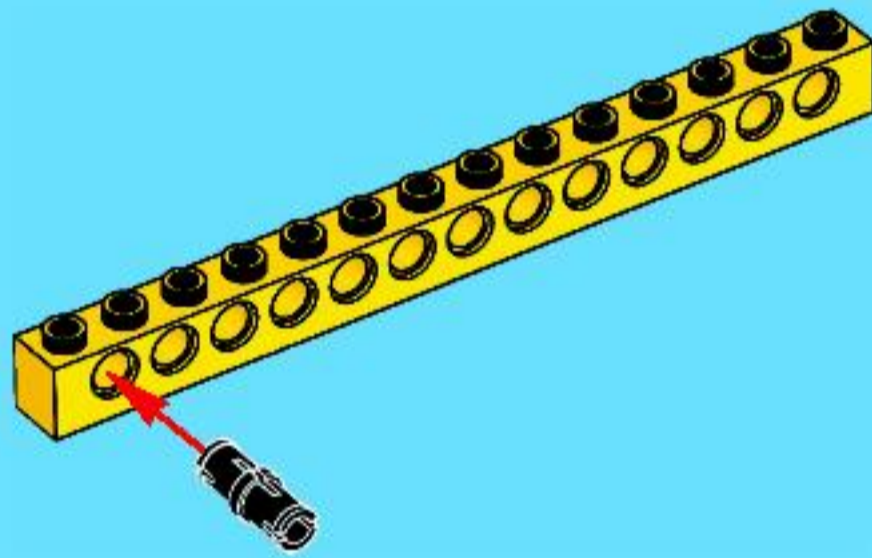

2

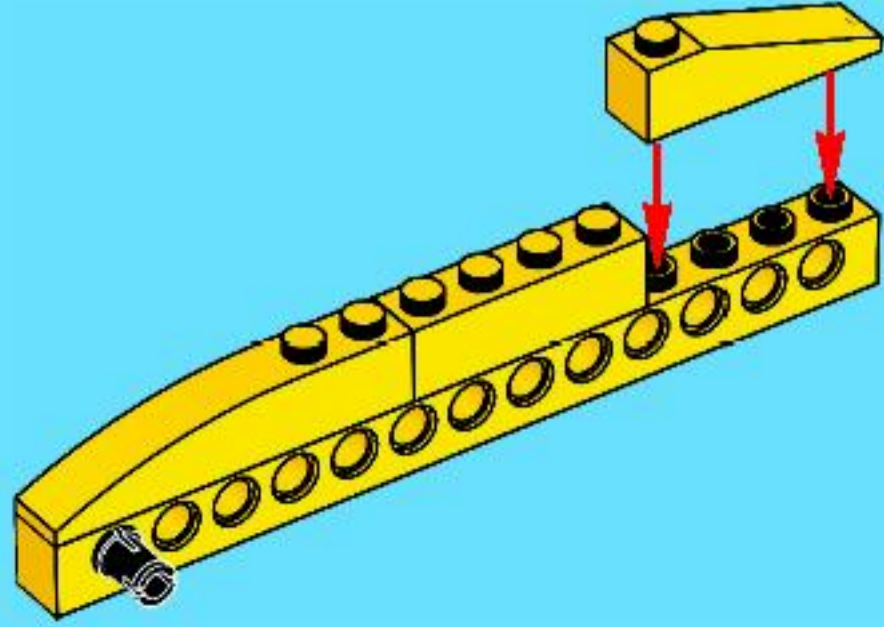

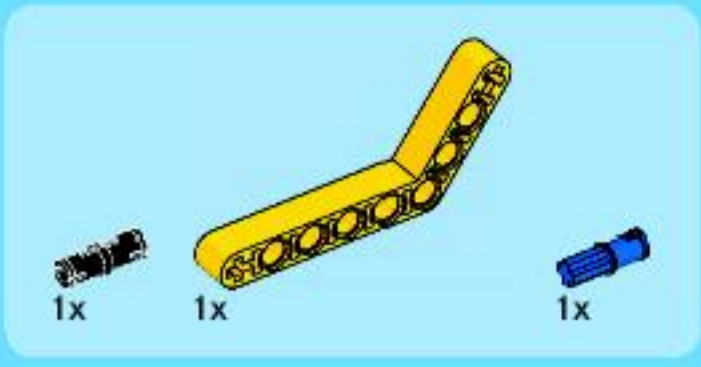

3

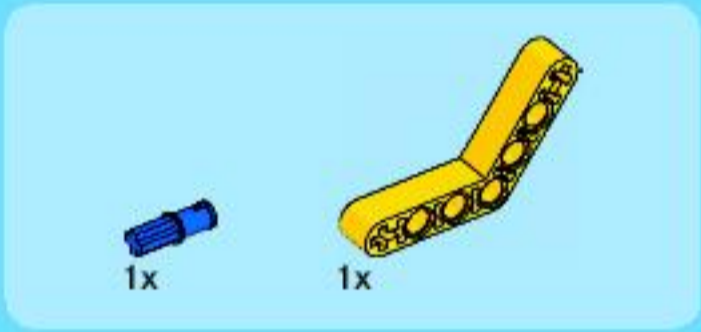
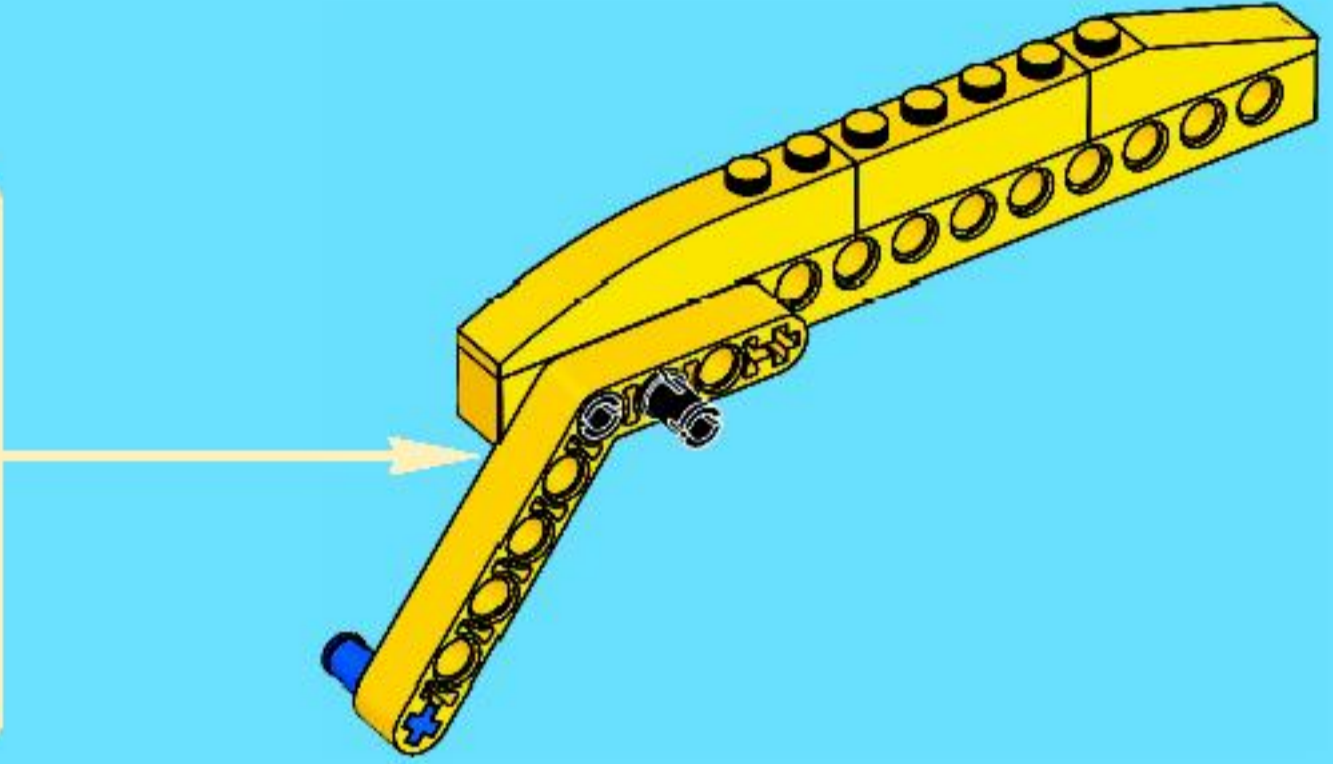
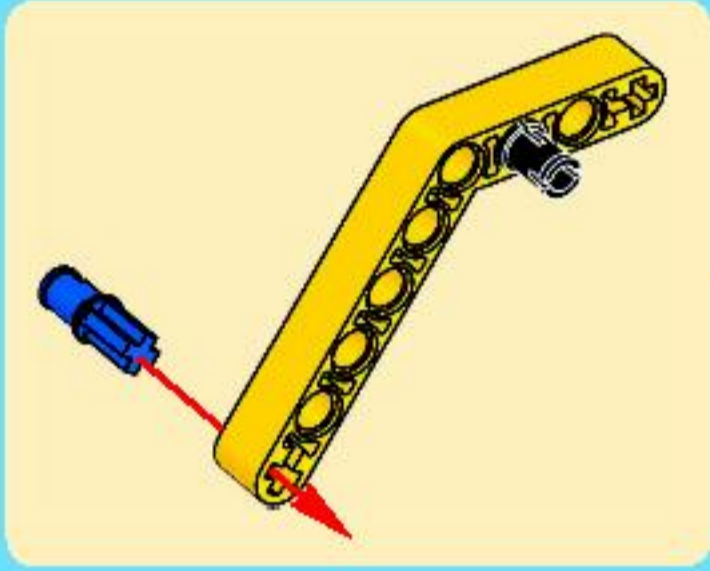

4

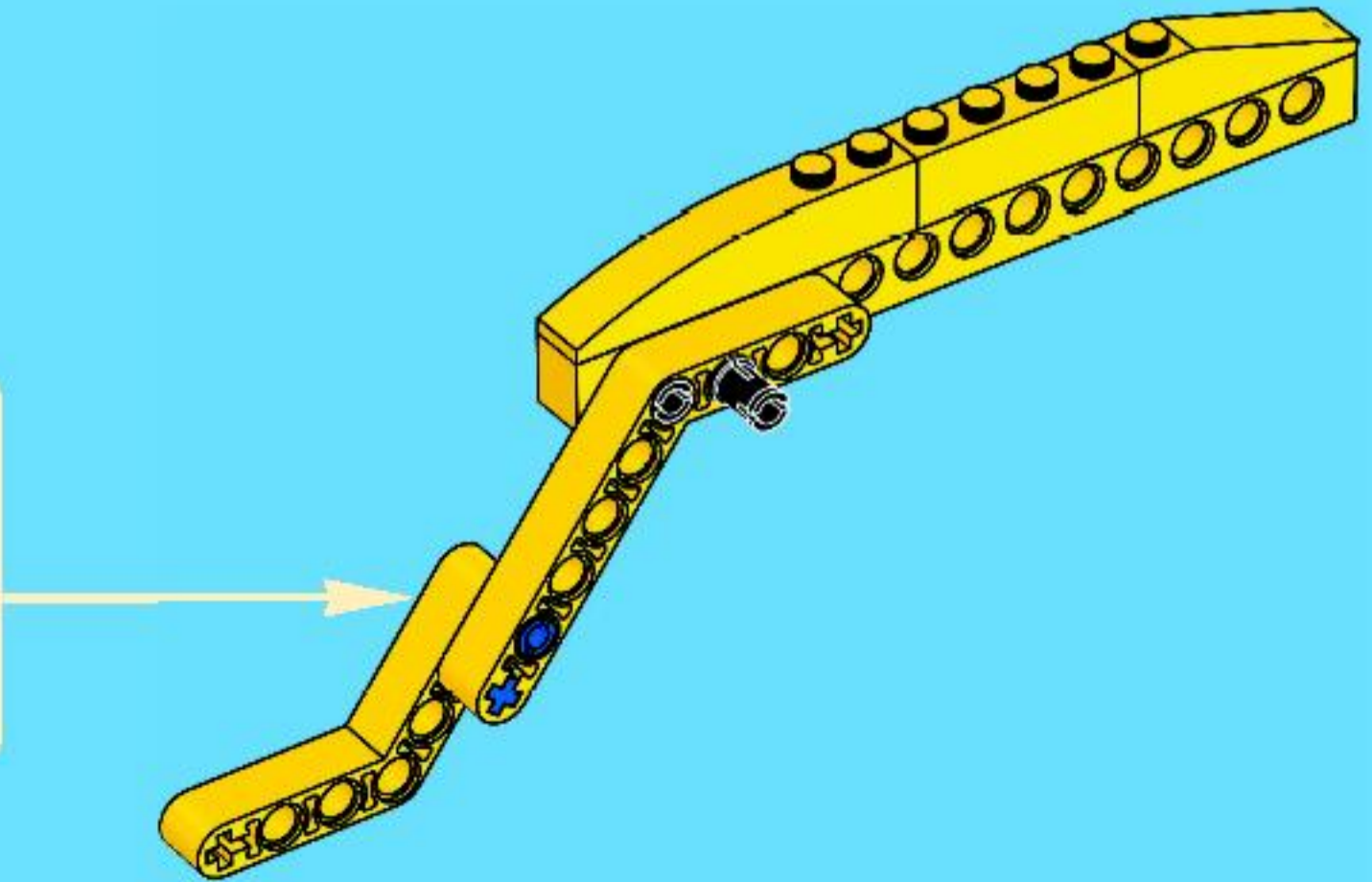
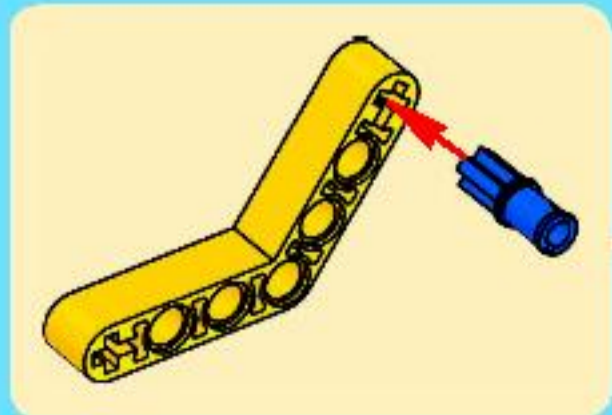

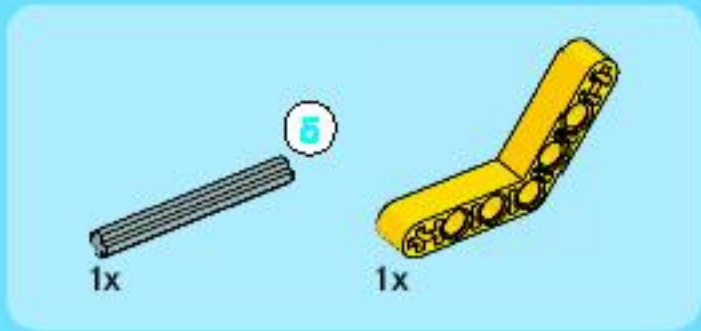

5

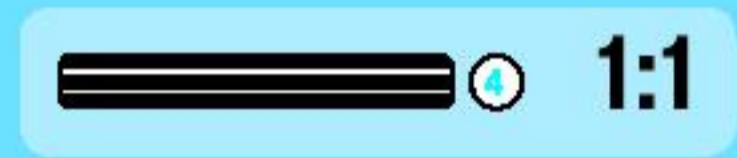
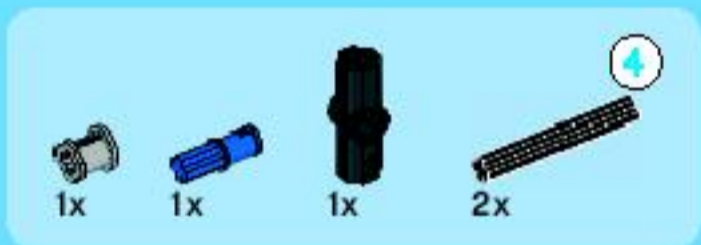
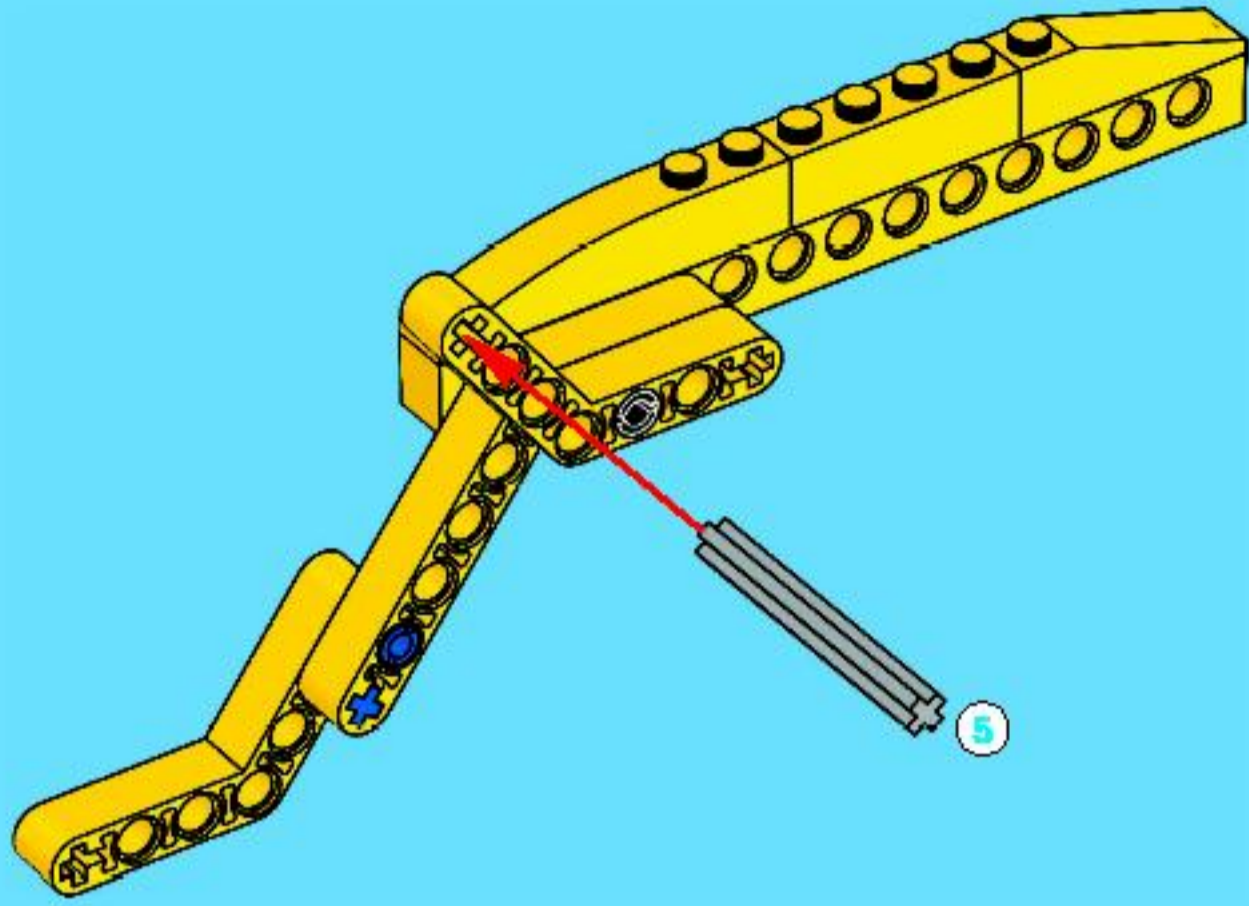

6

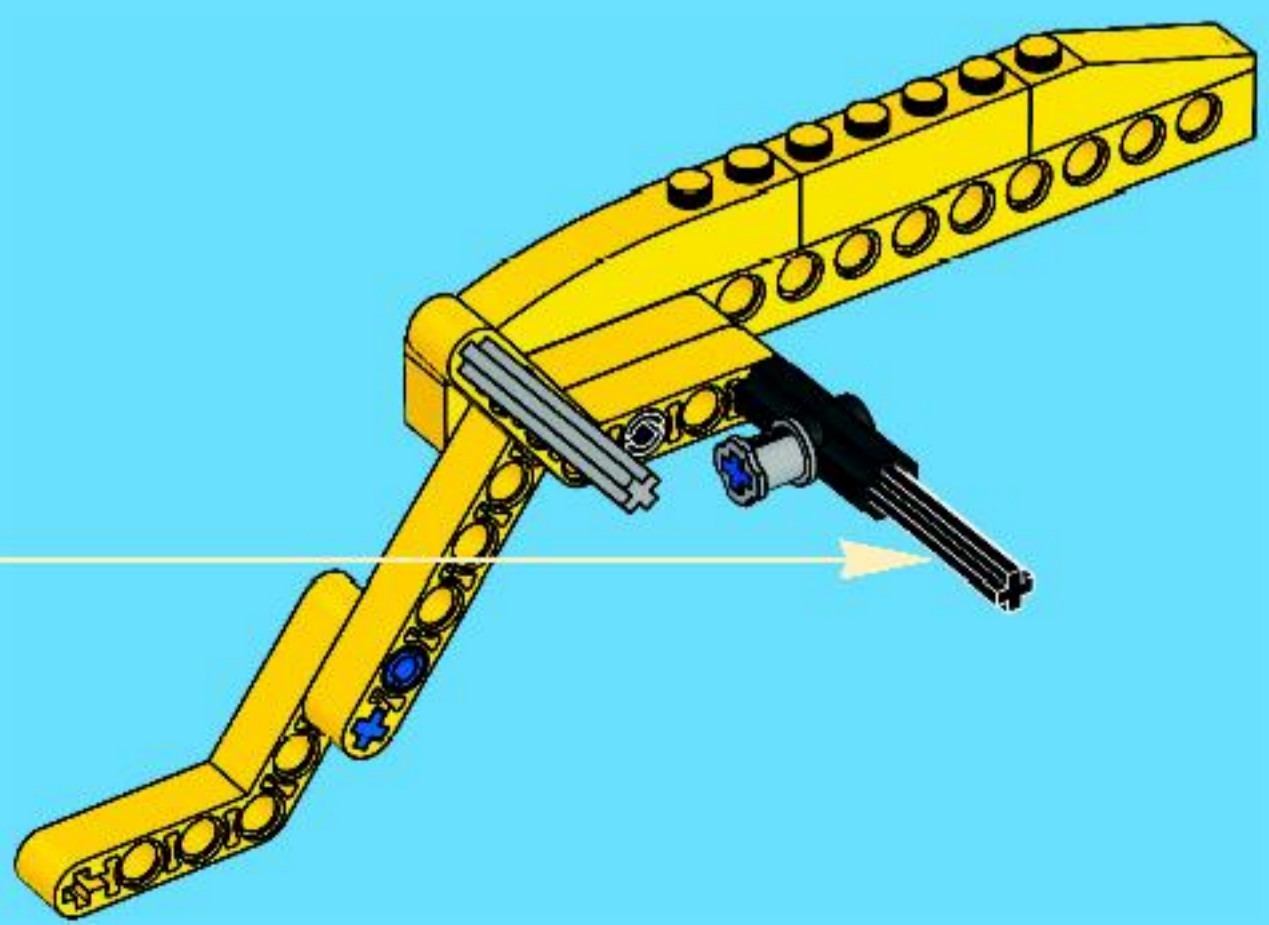
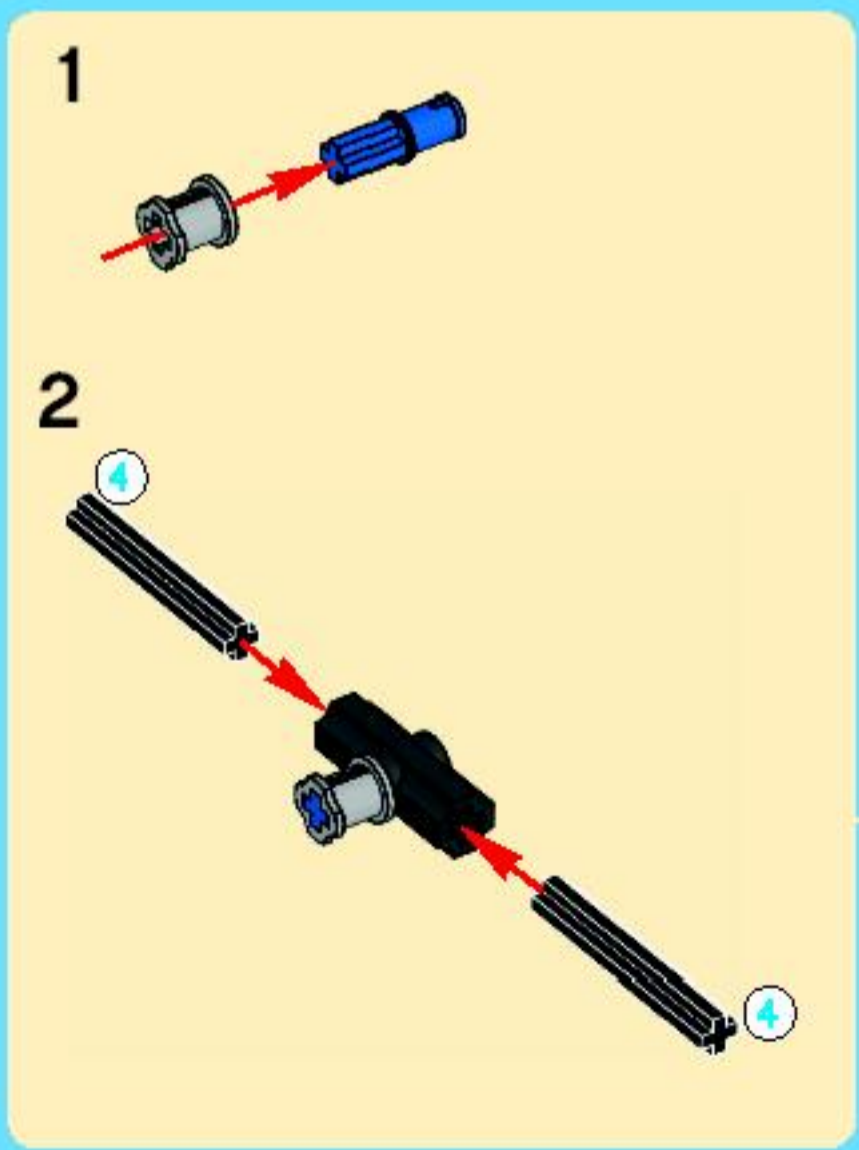

107

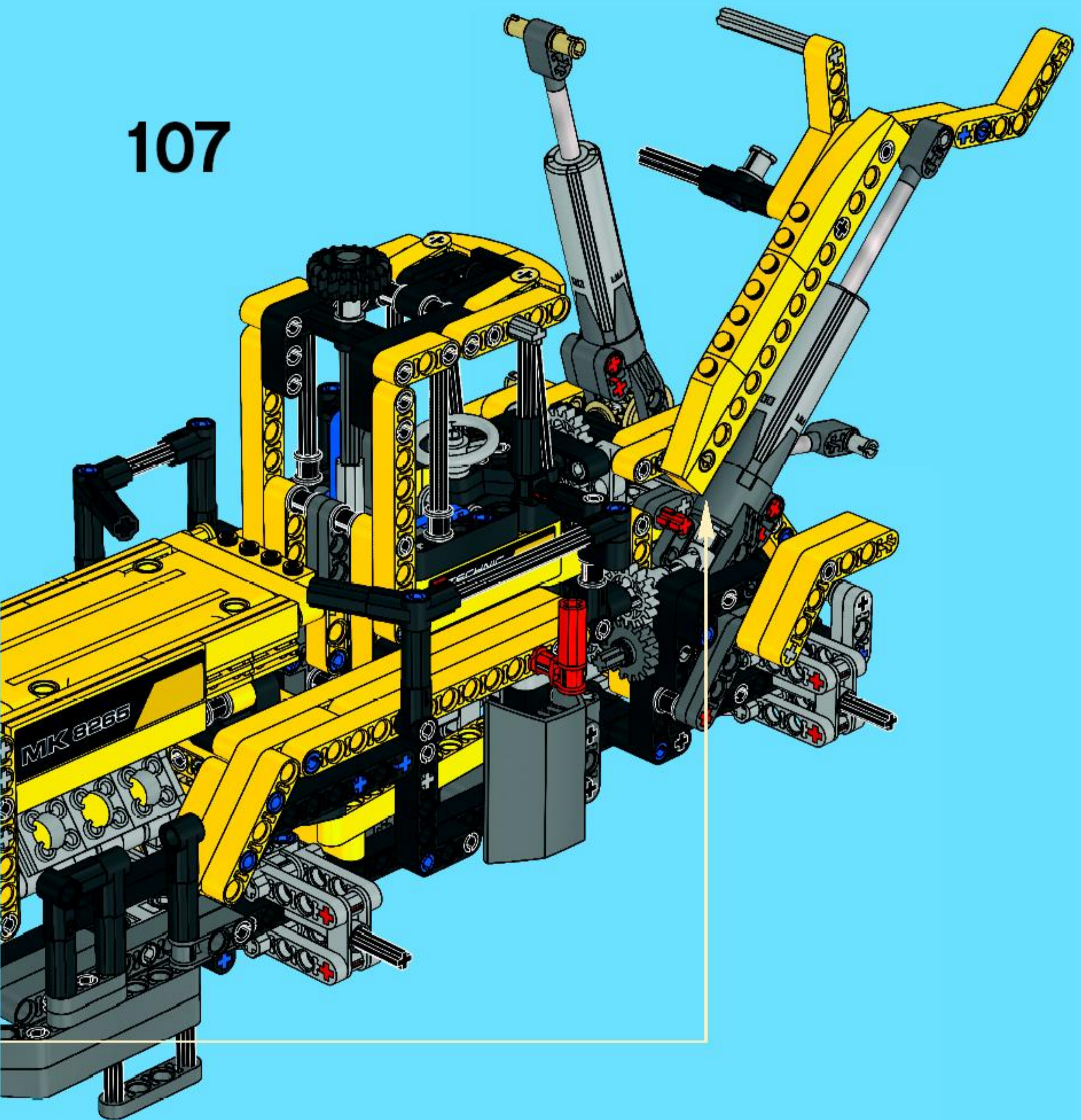

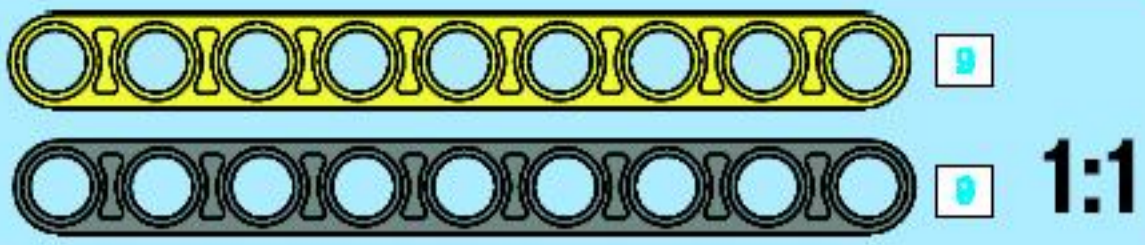
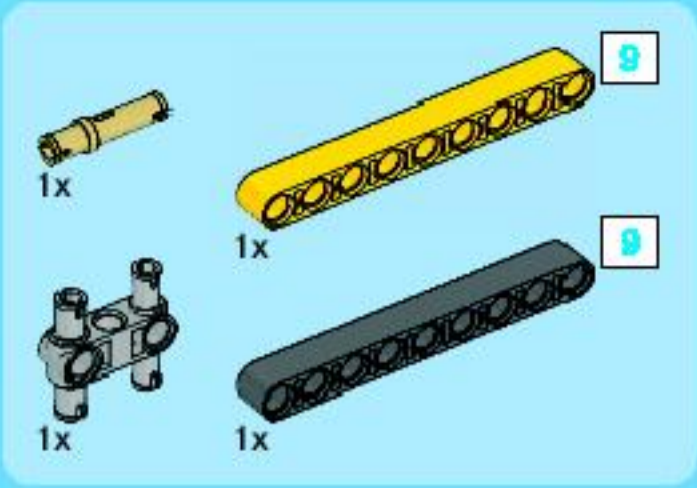

108

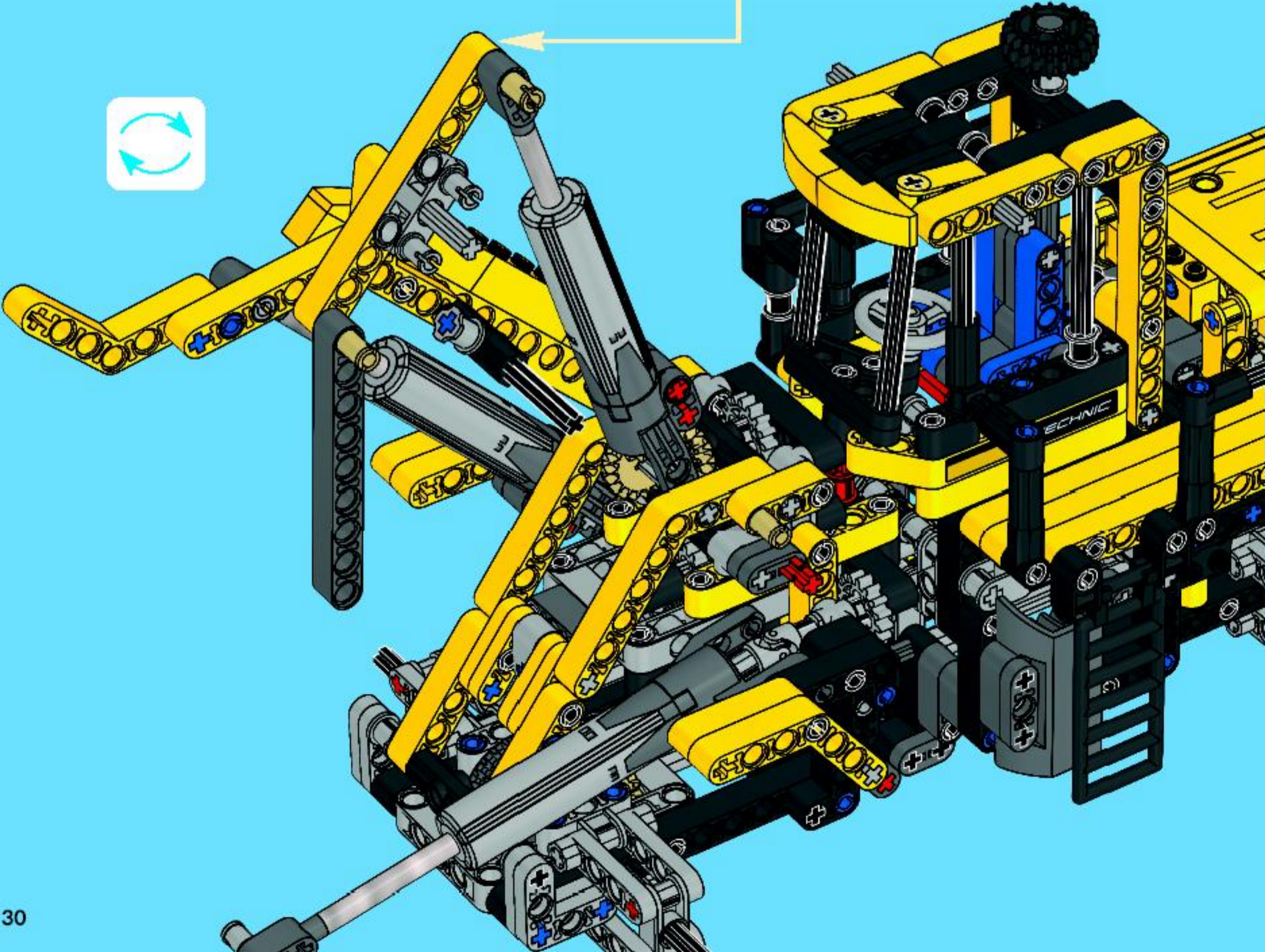
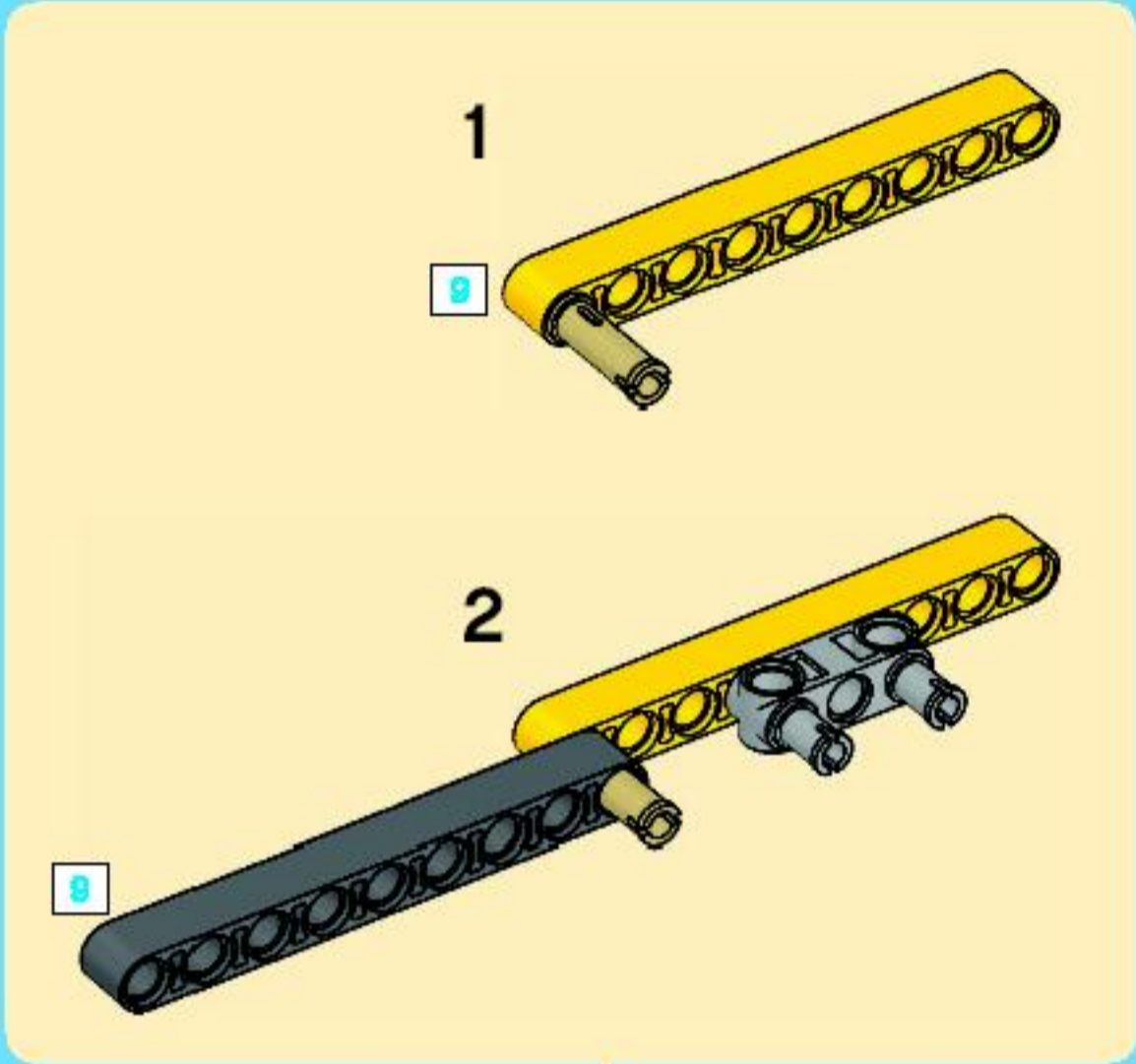

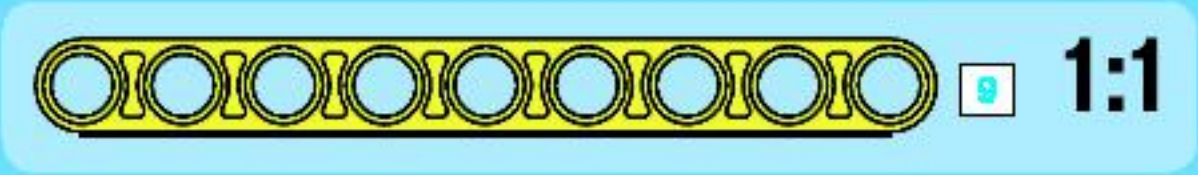
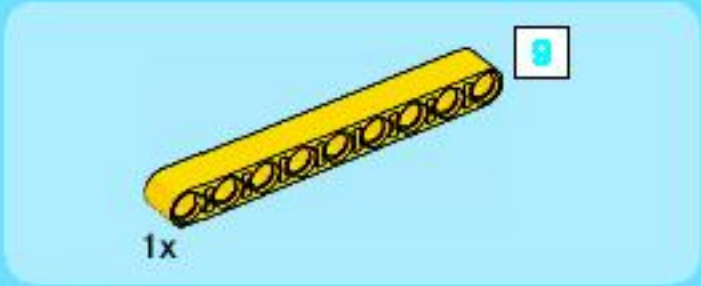

109

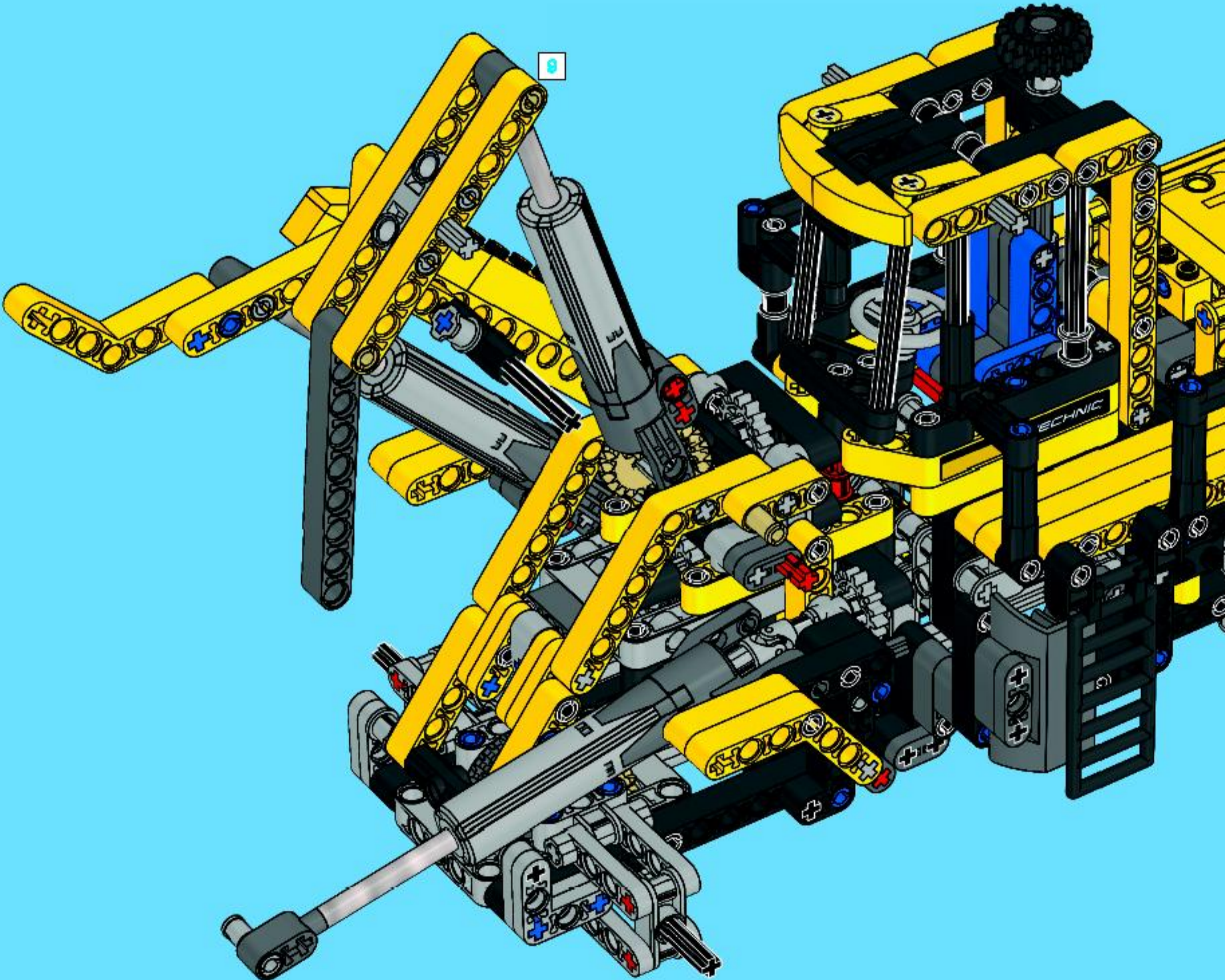

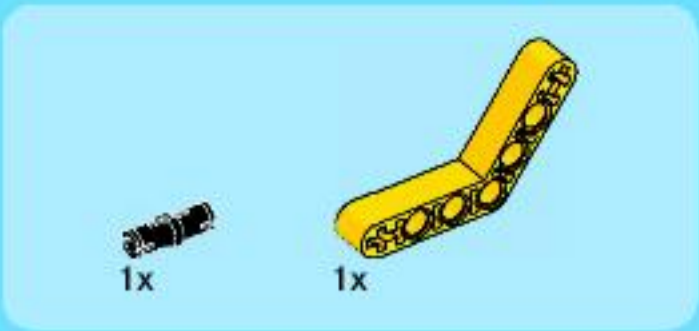

110

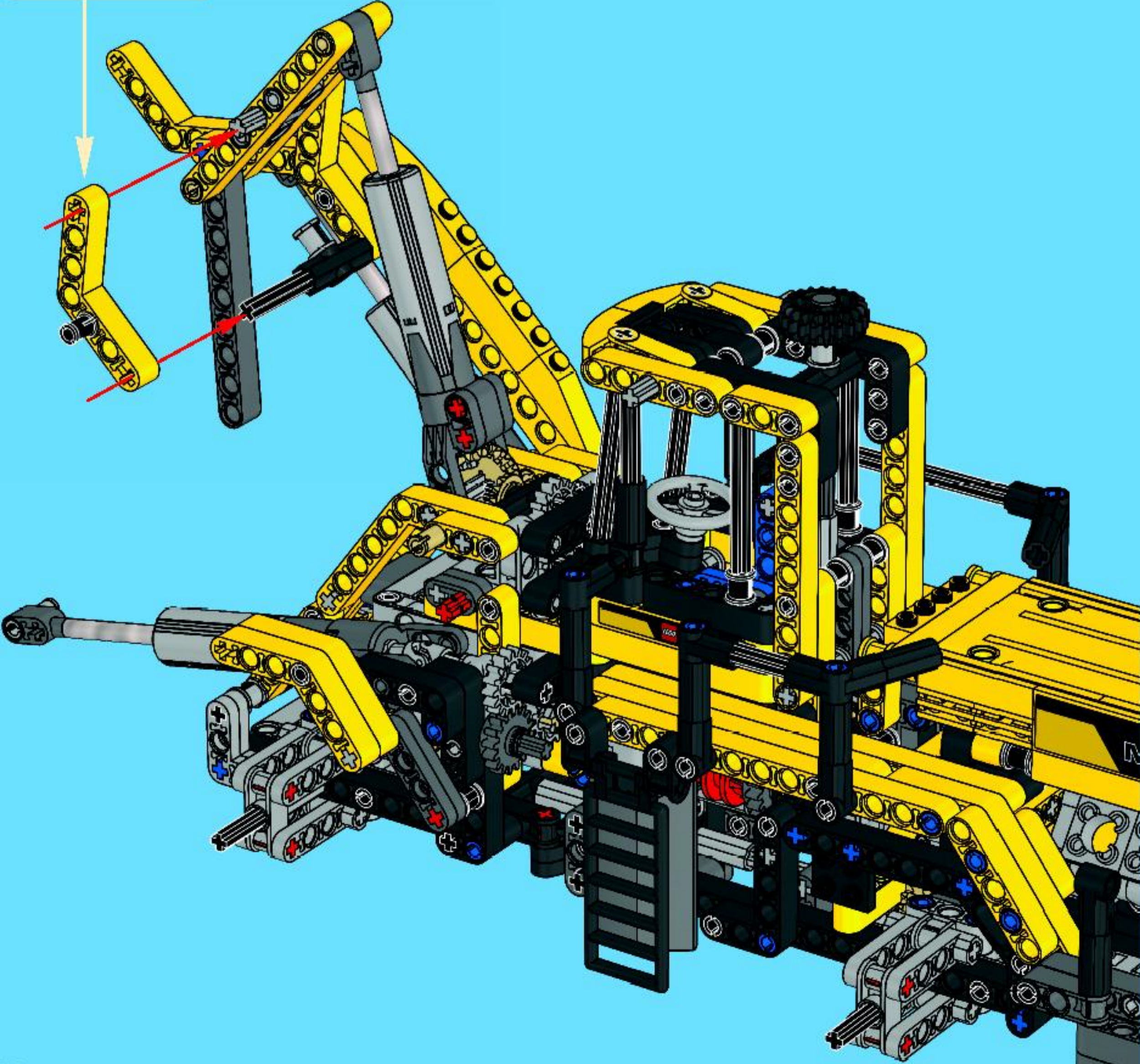

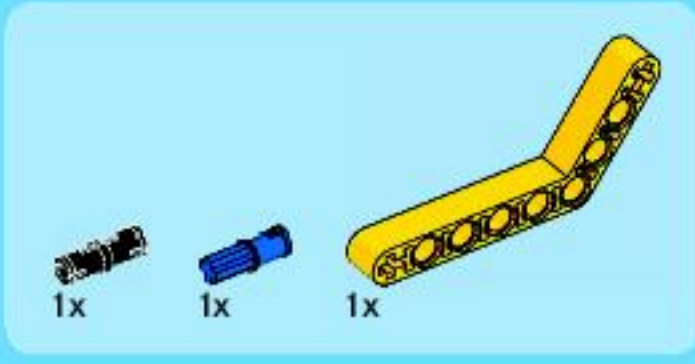

111

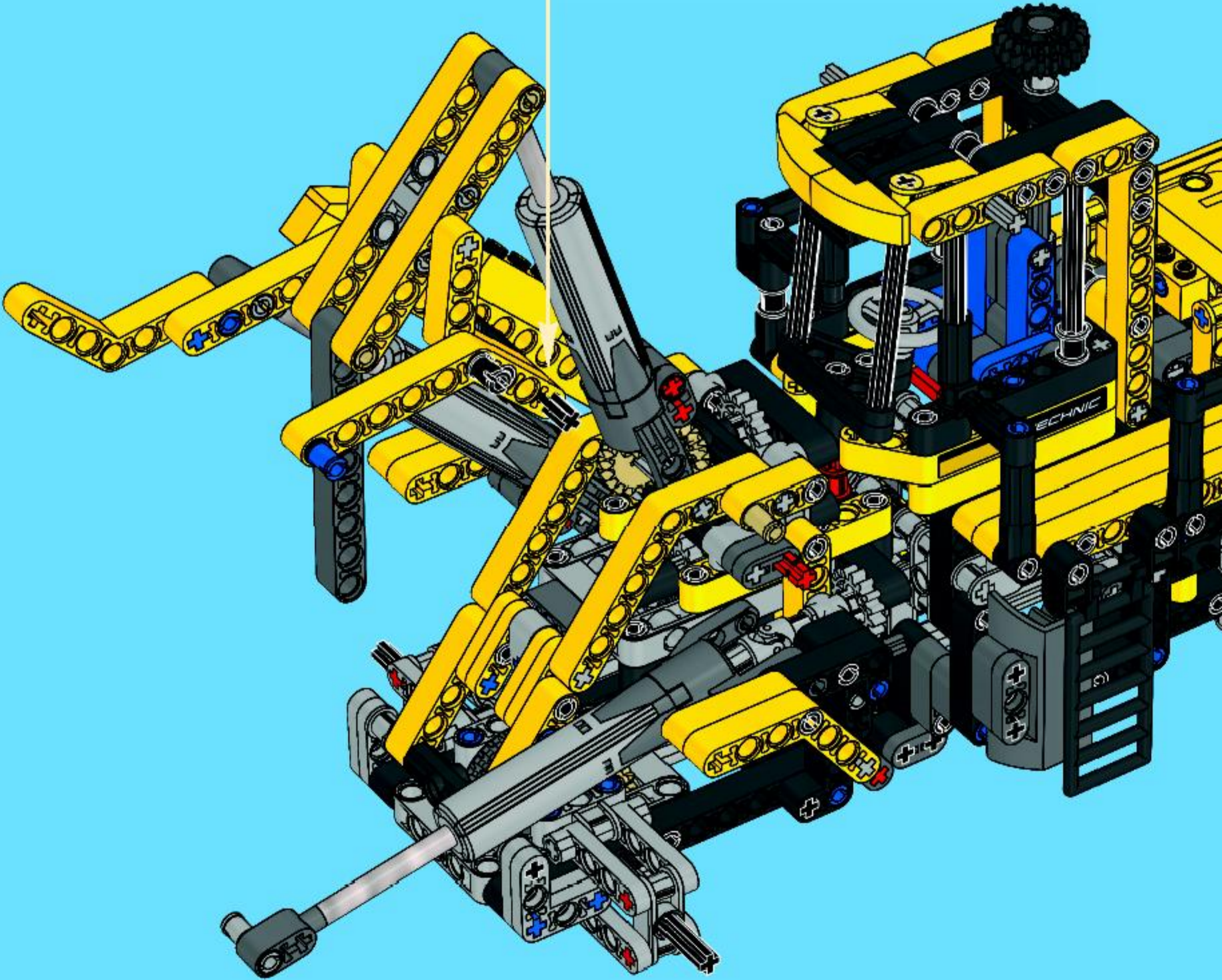
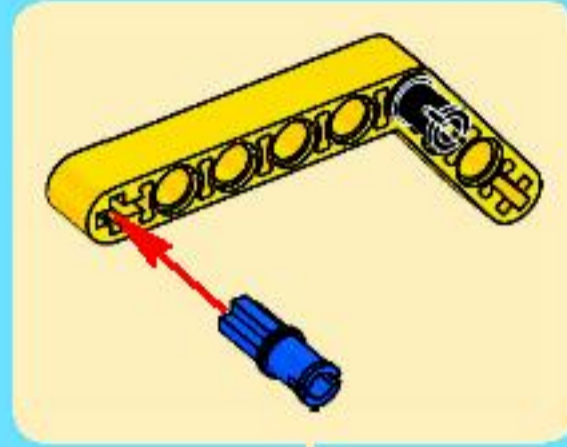

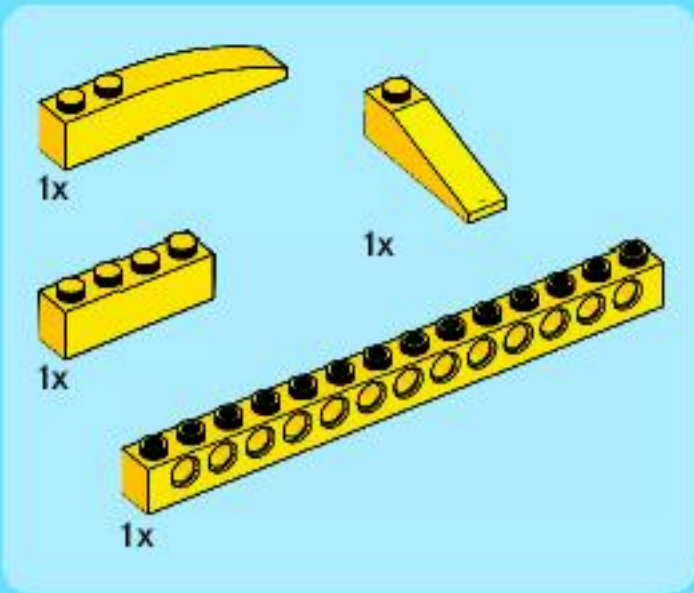

112

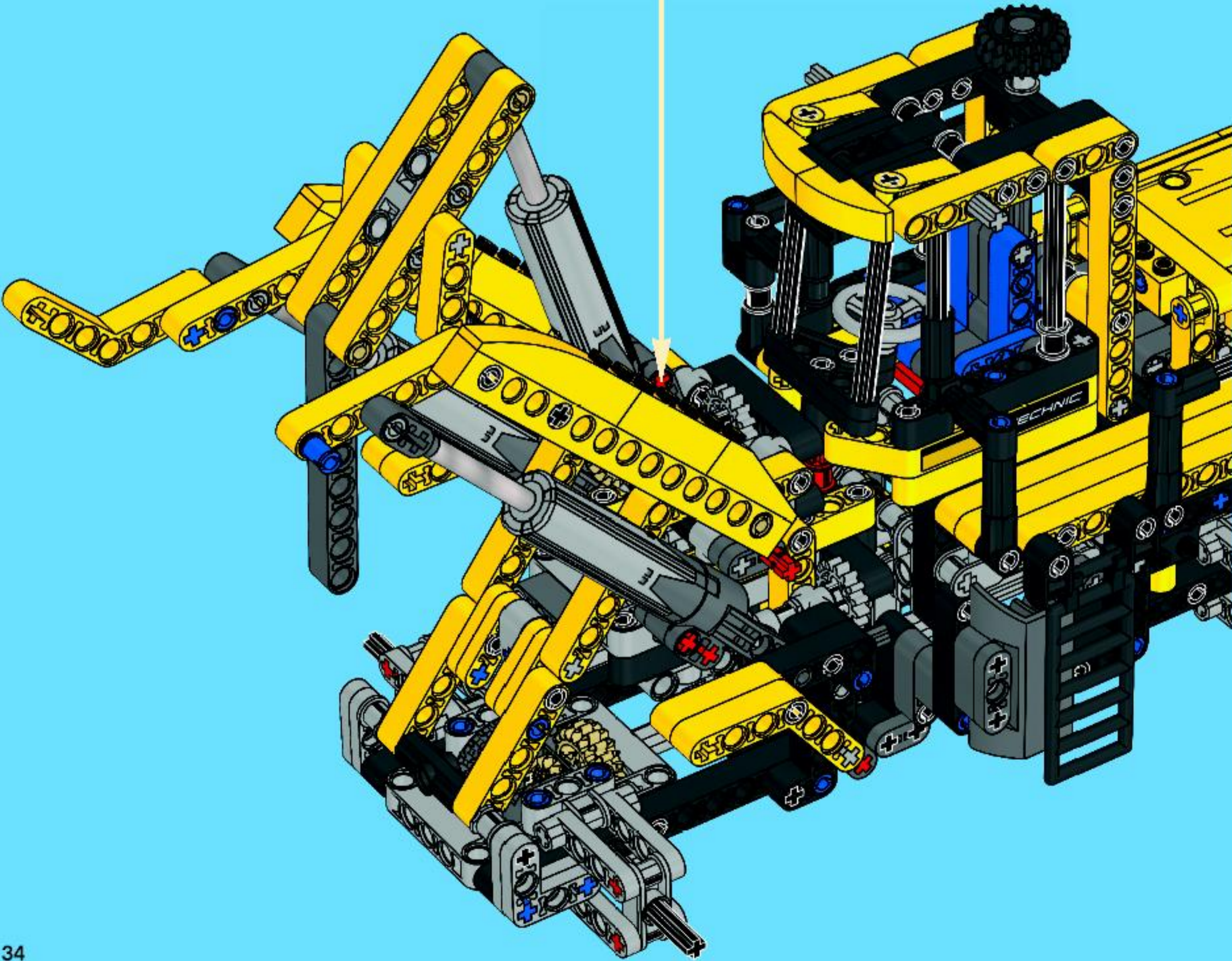
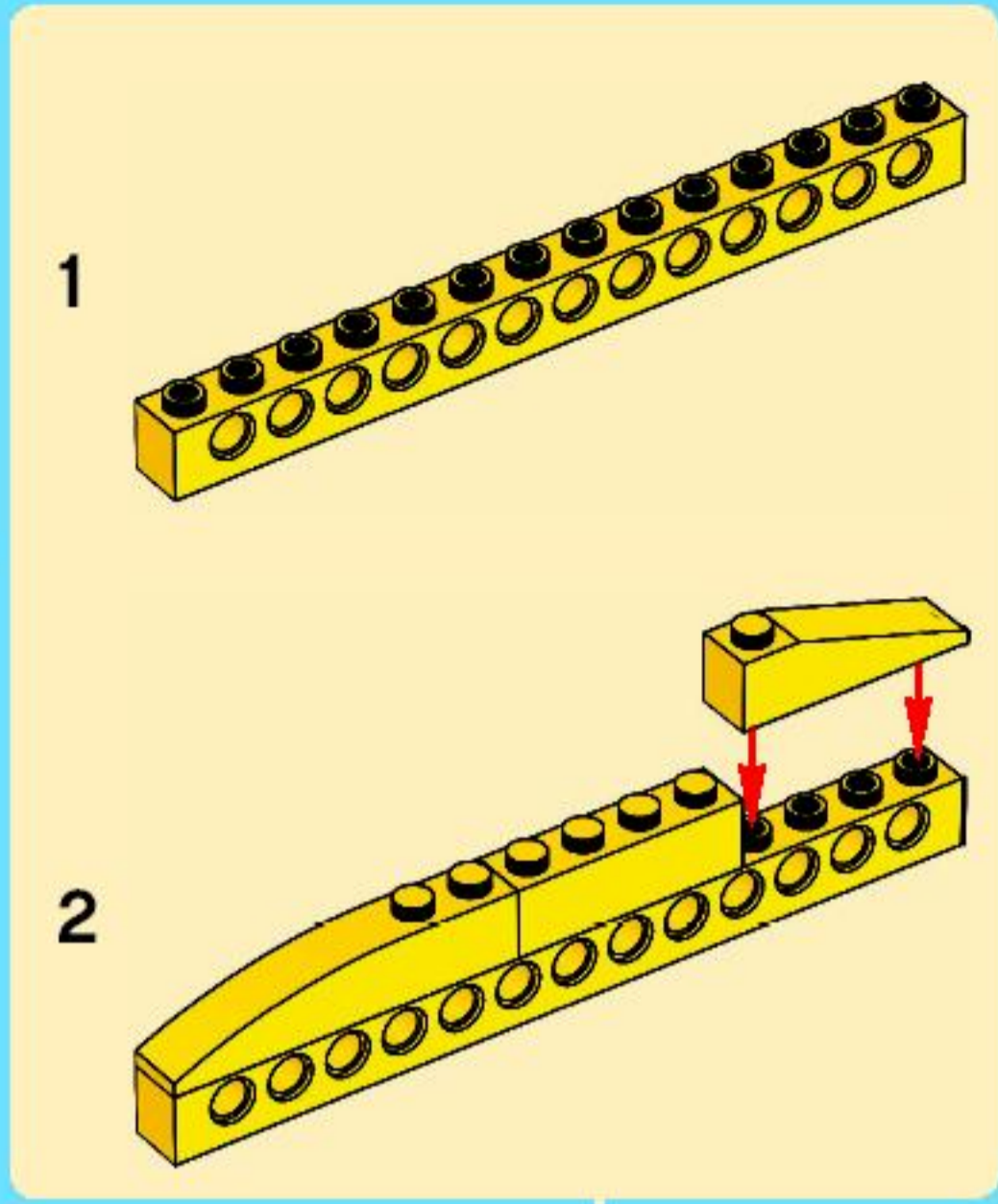

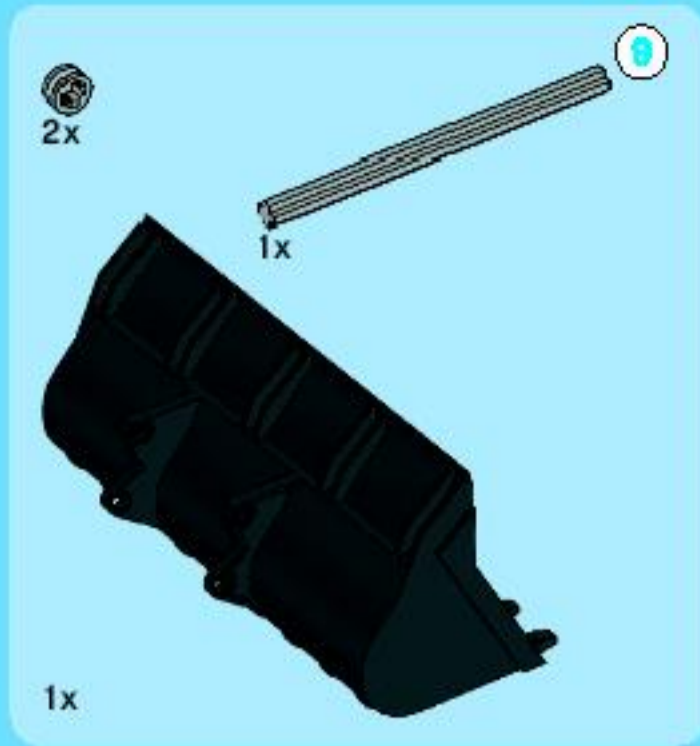

113

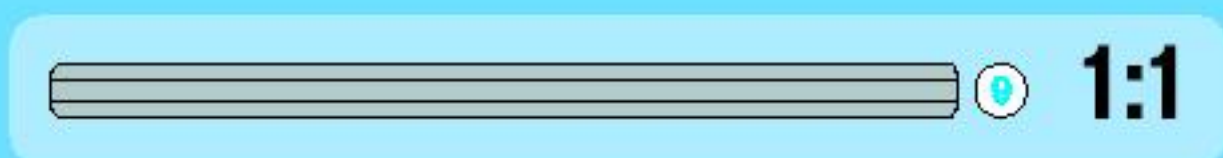
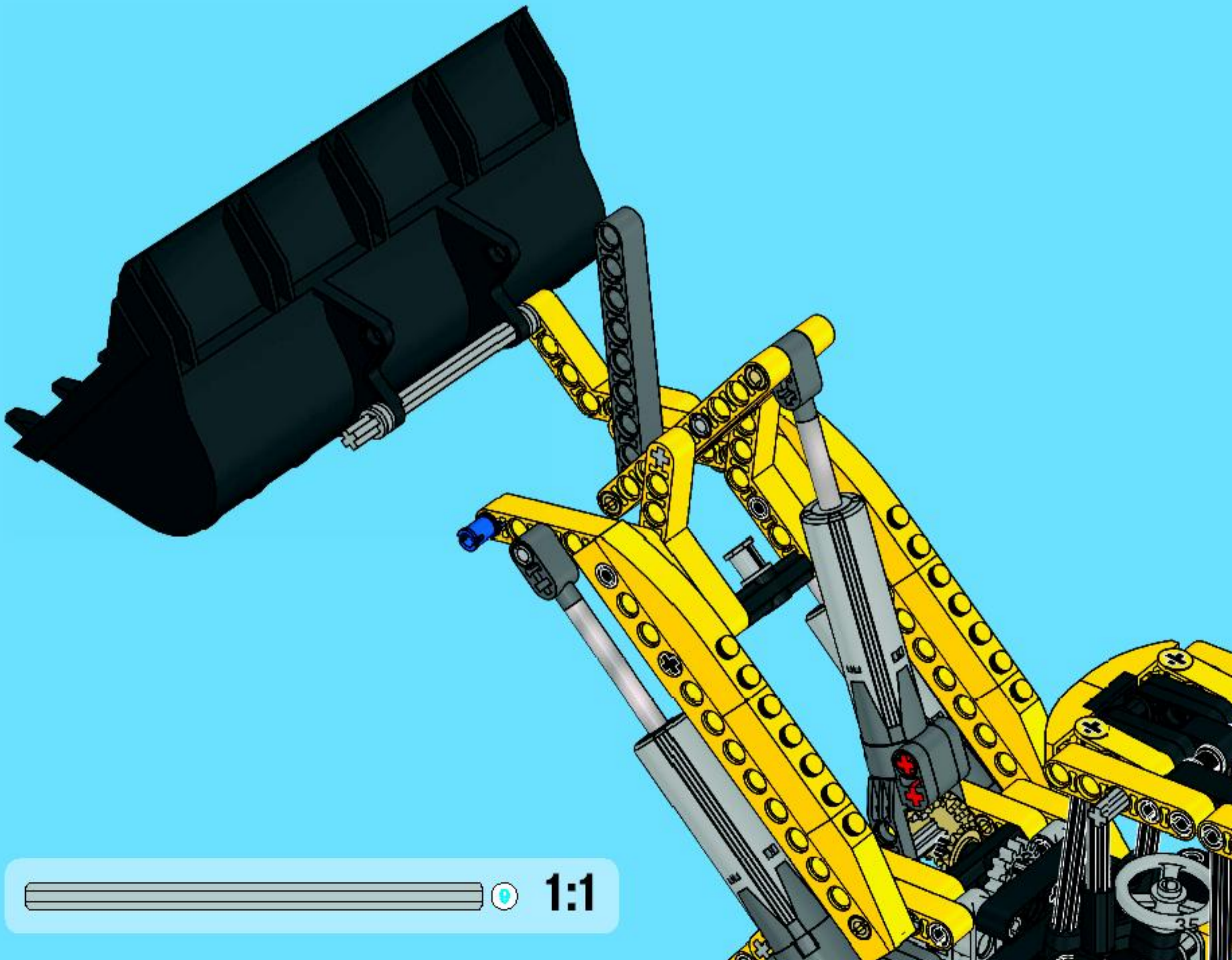
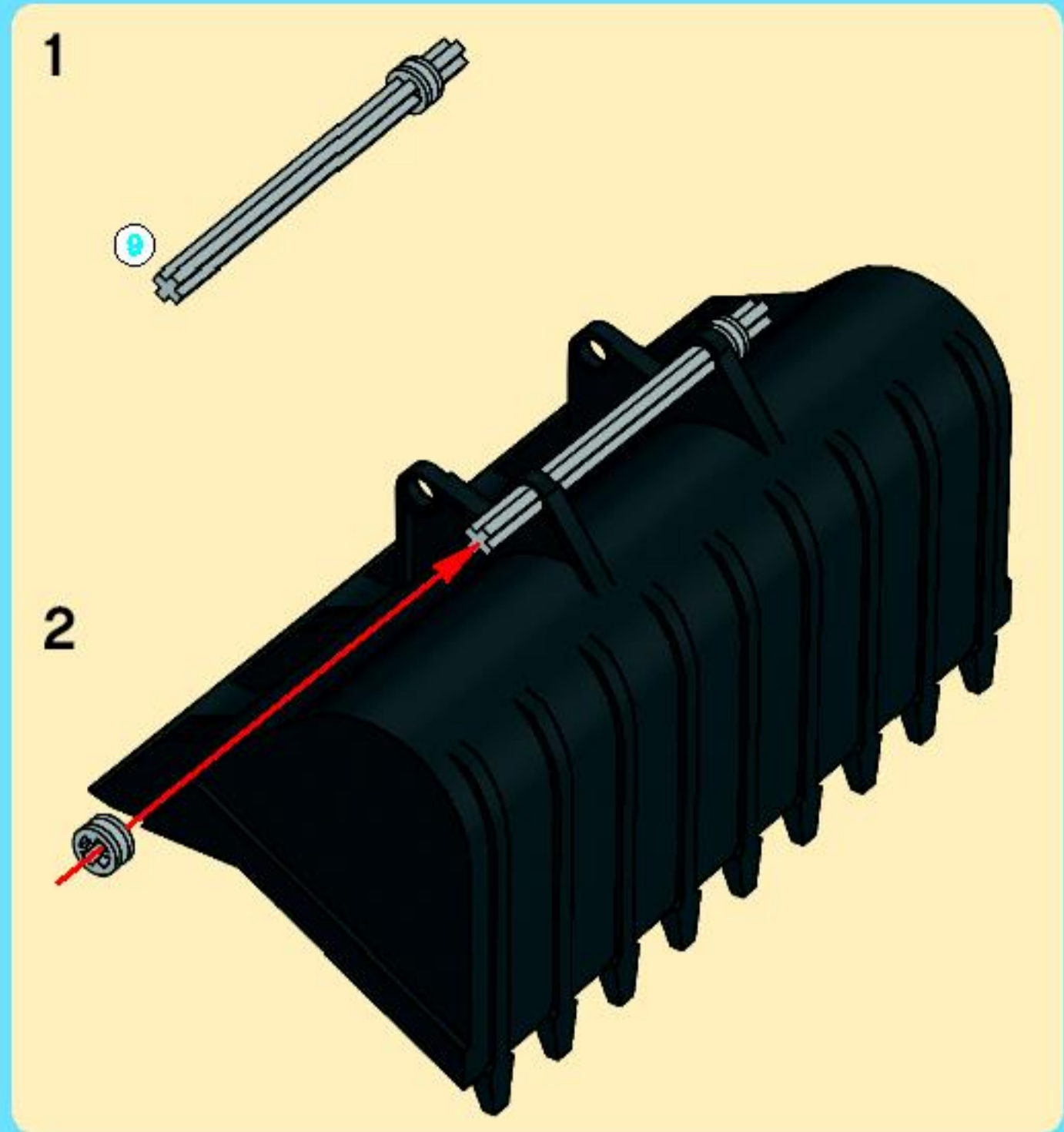

2x

1x

8



1:1

114

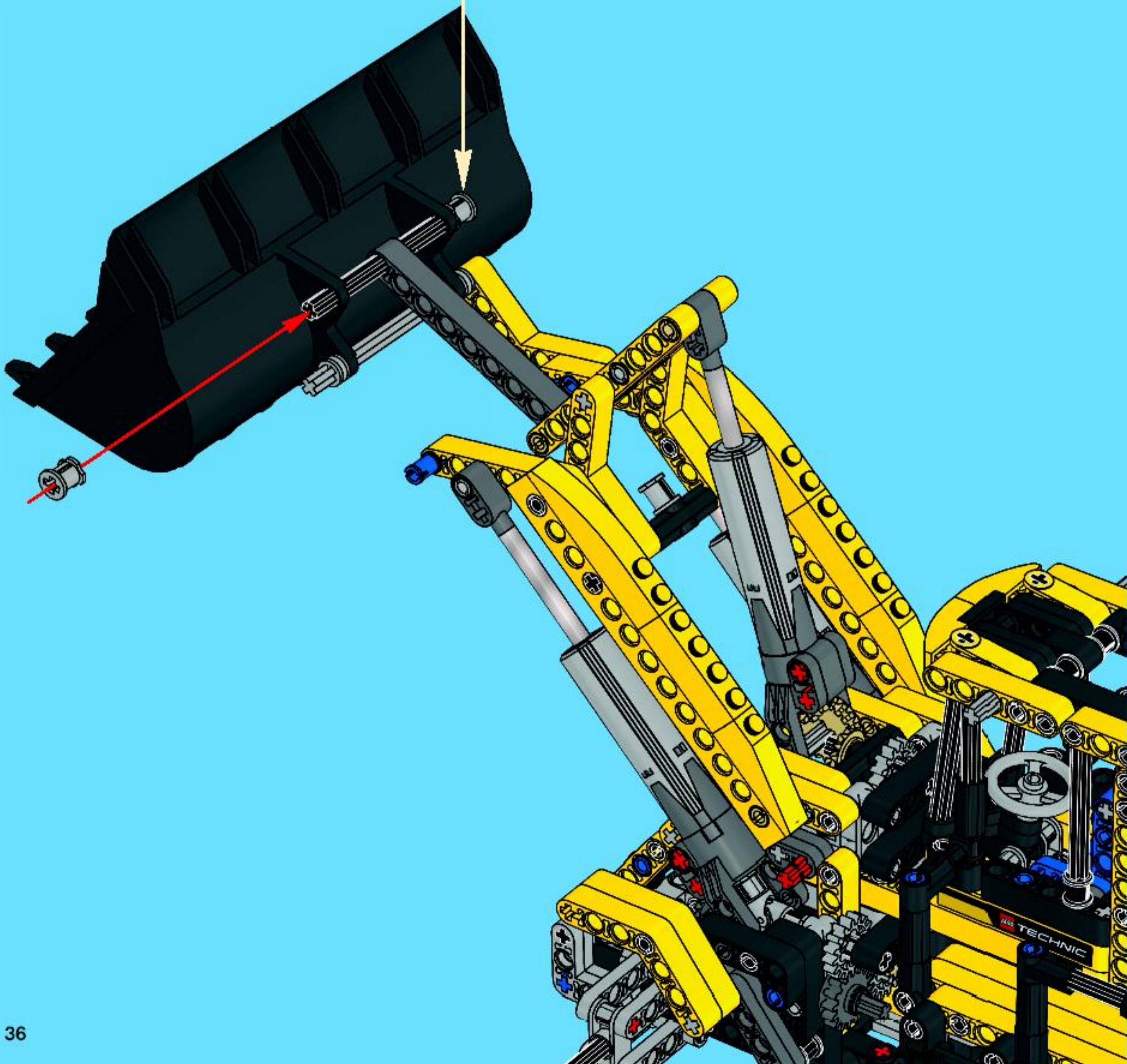
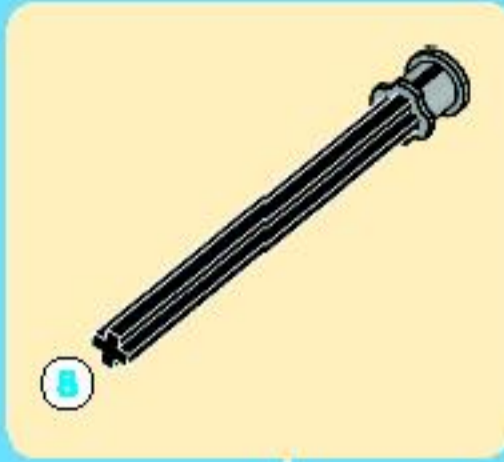

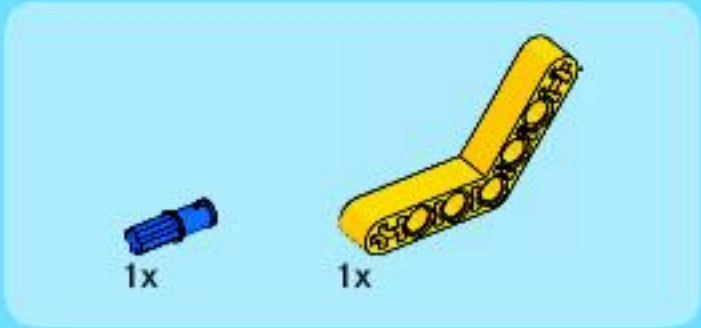

115

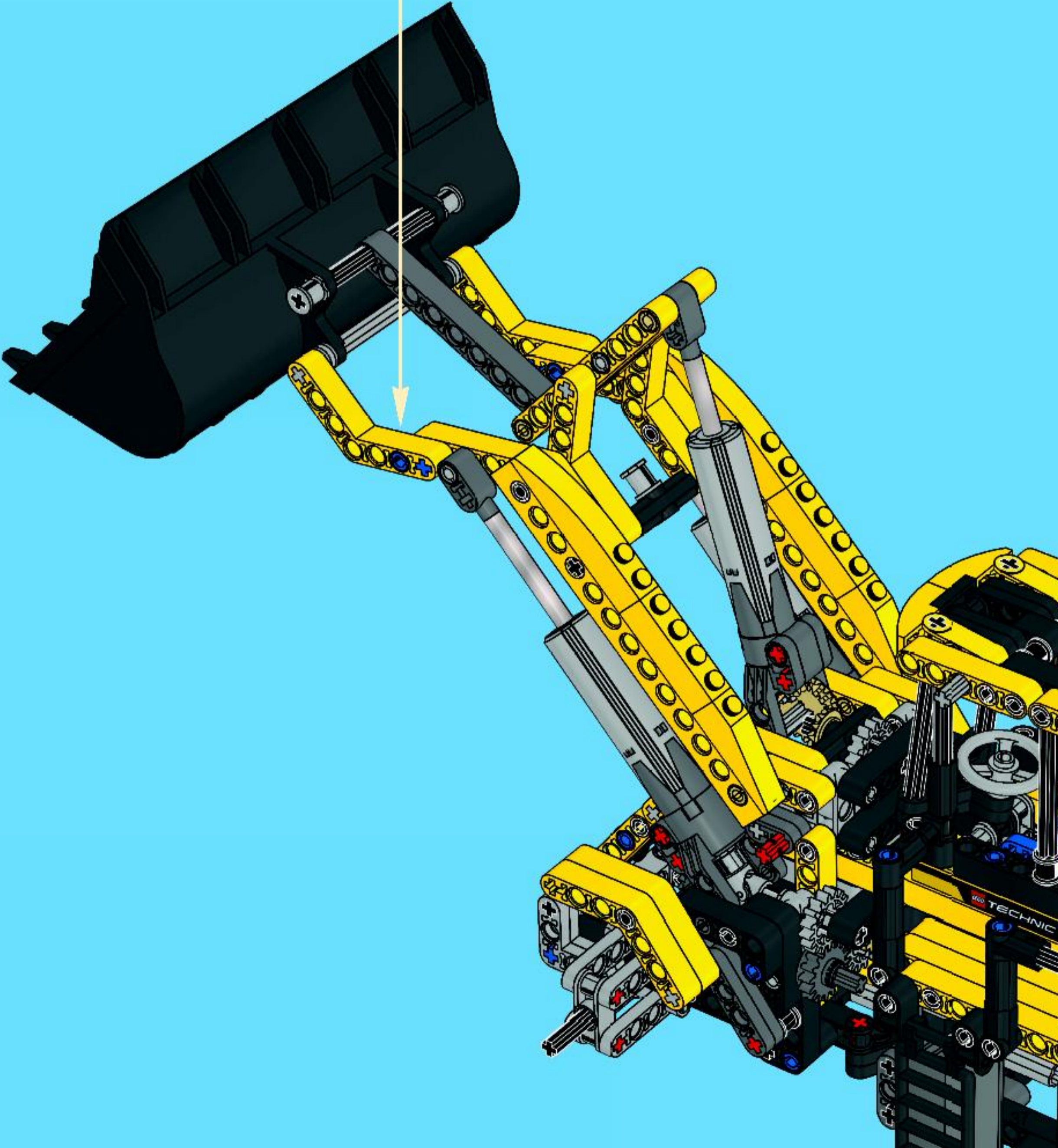
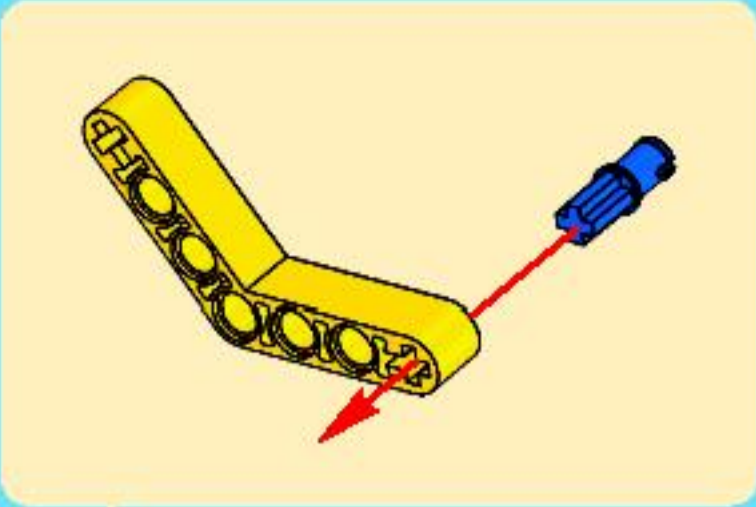



116

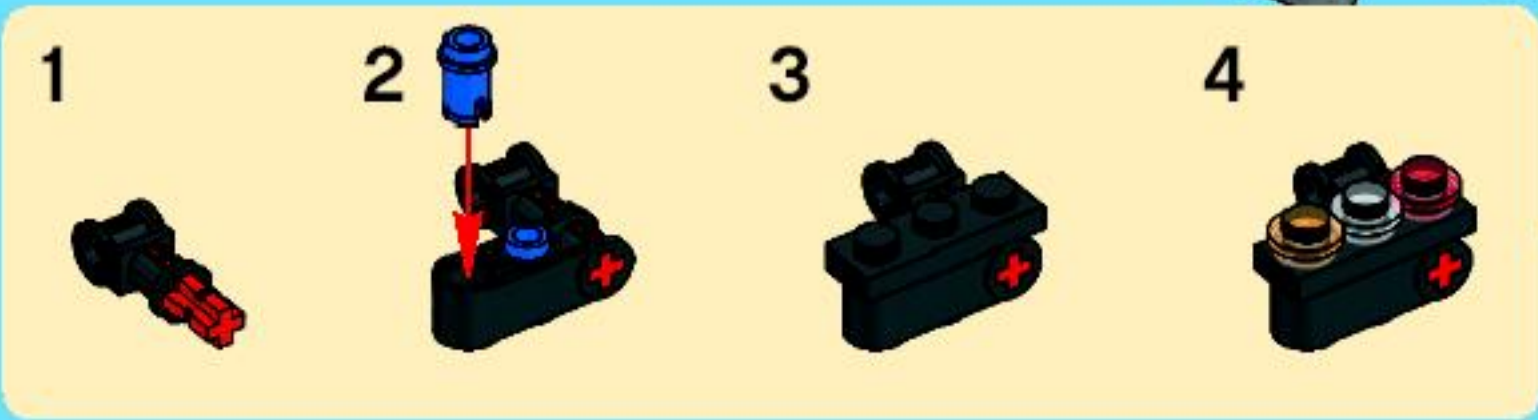
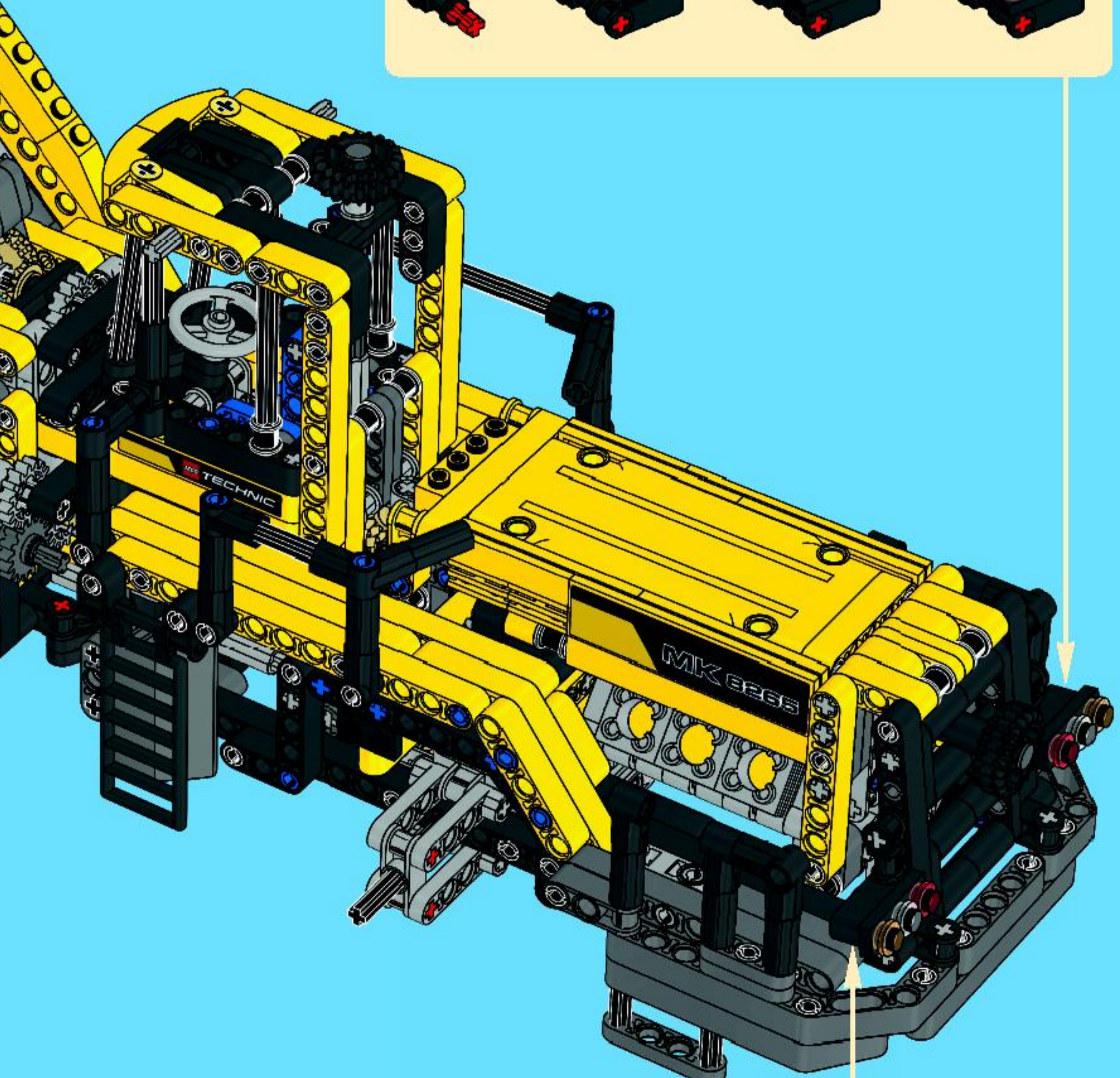
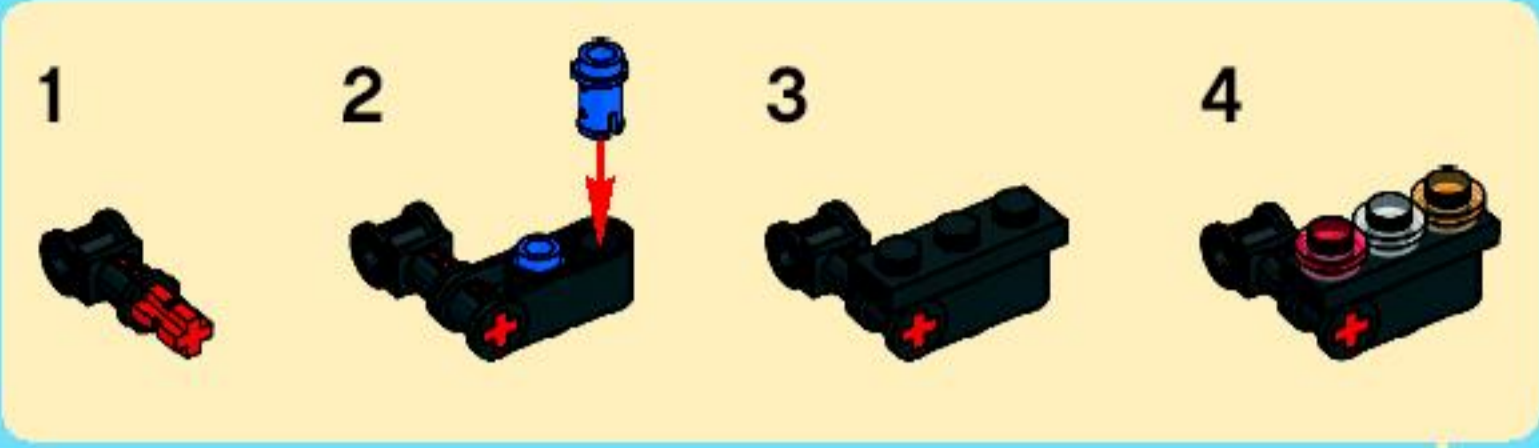



117

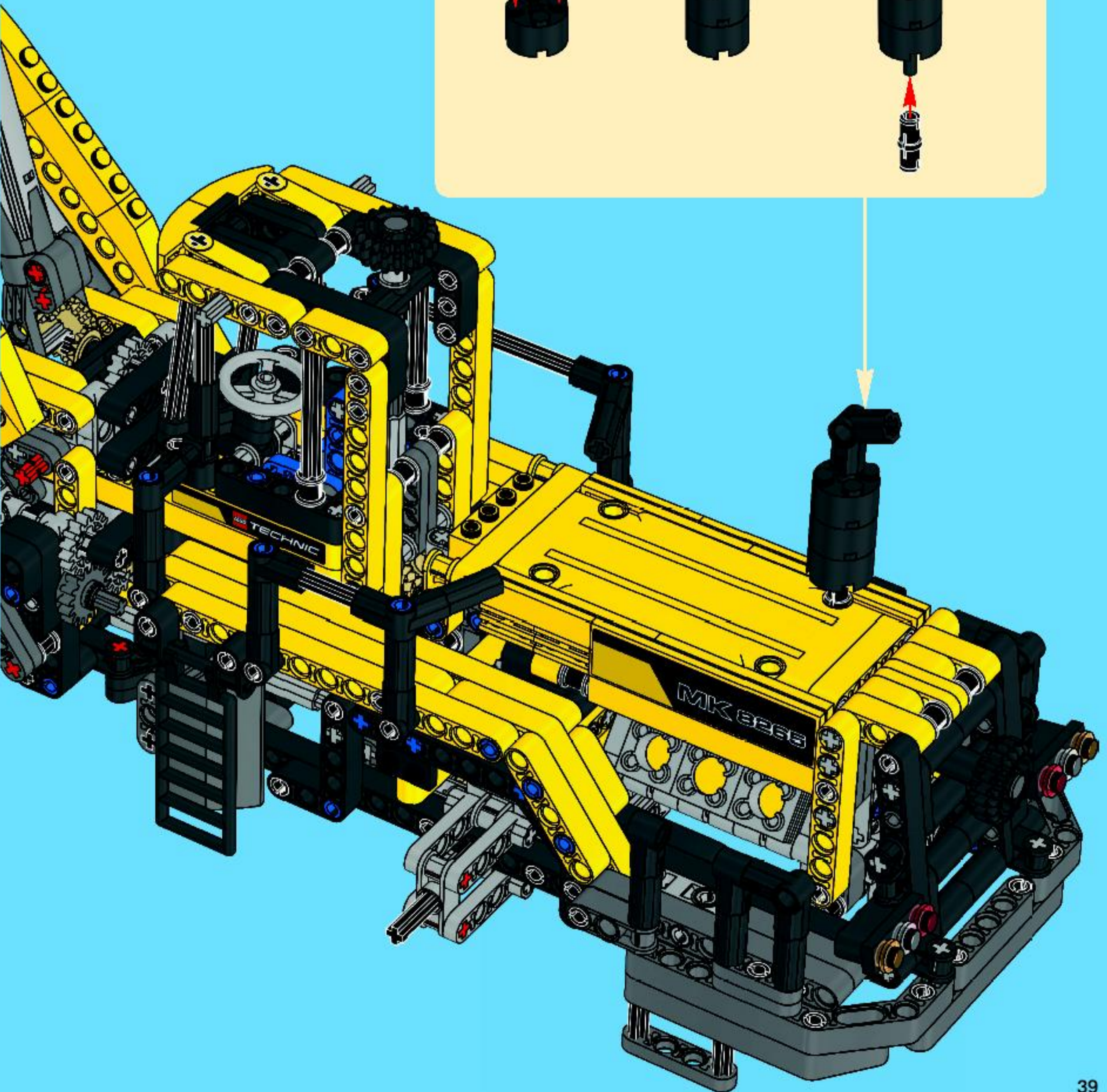
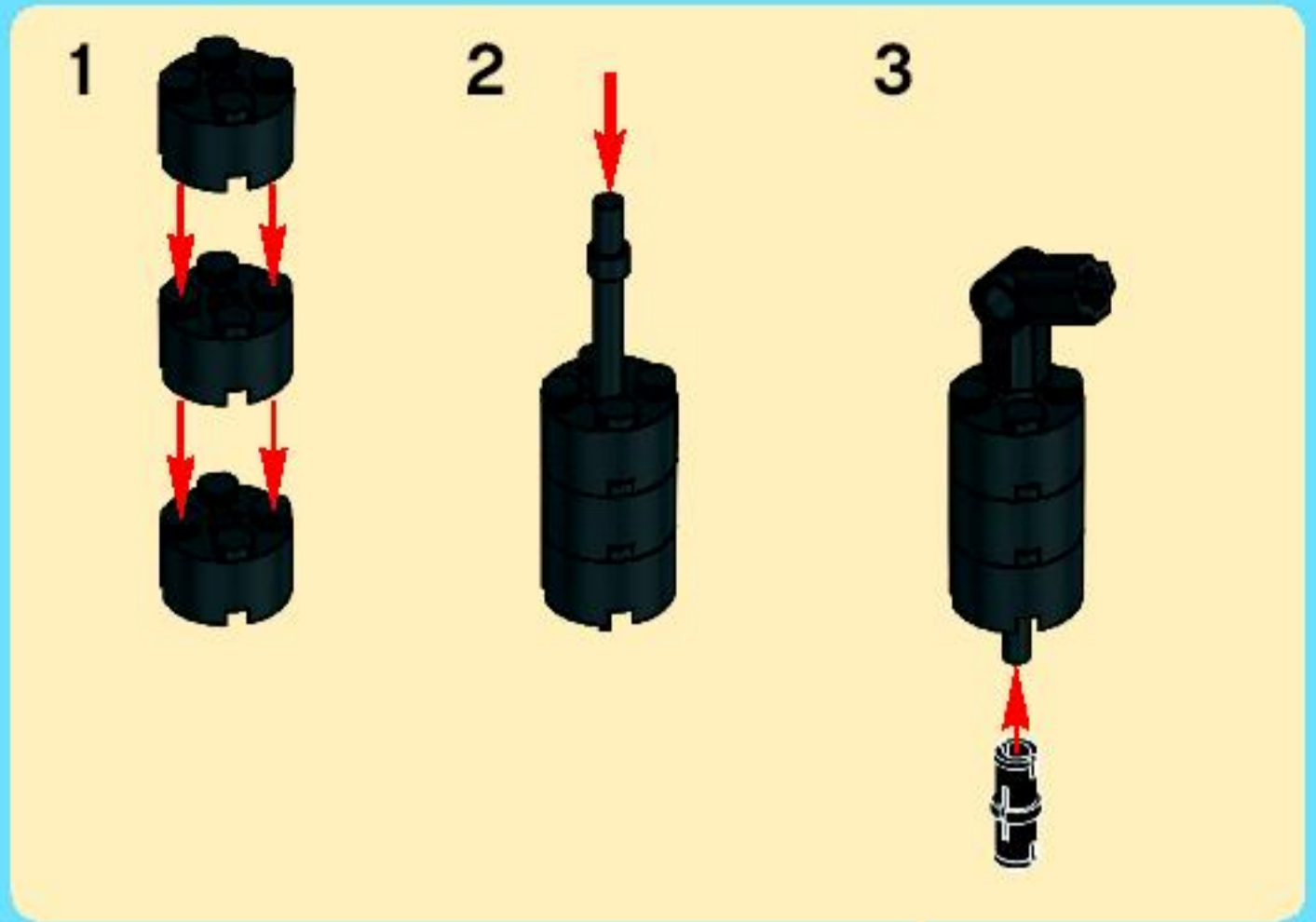



118

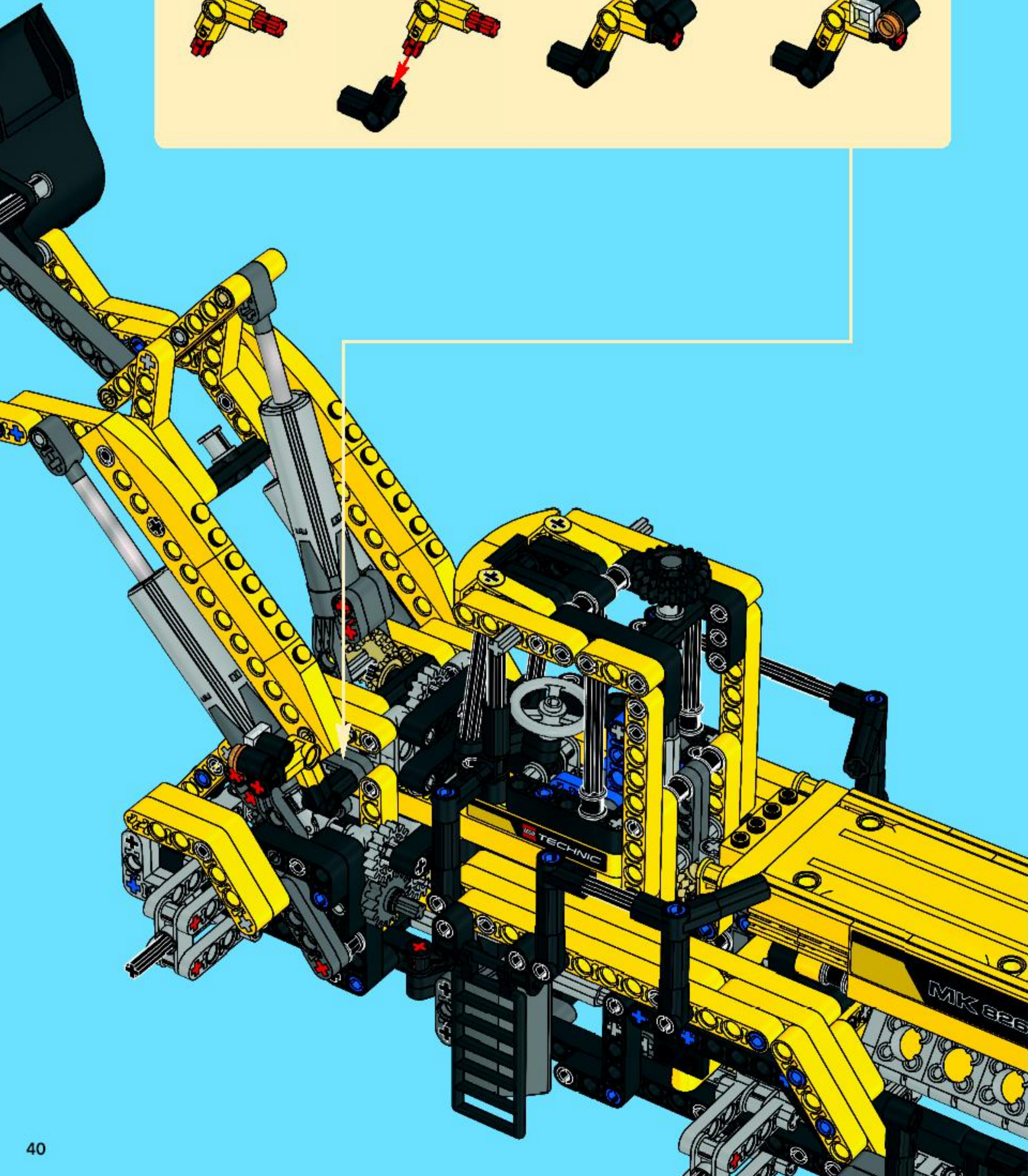
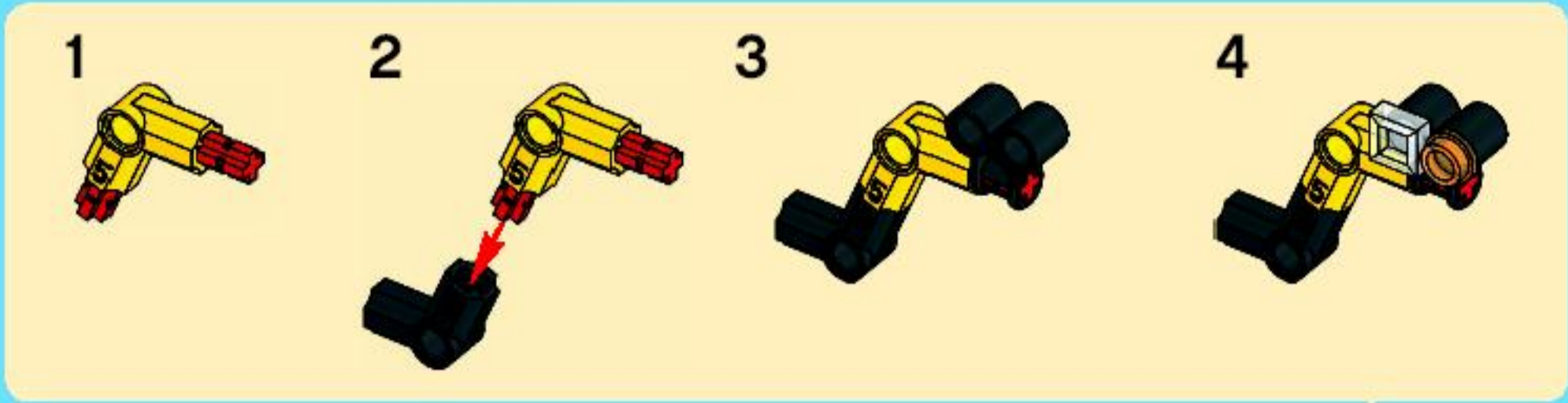



119

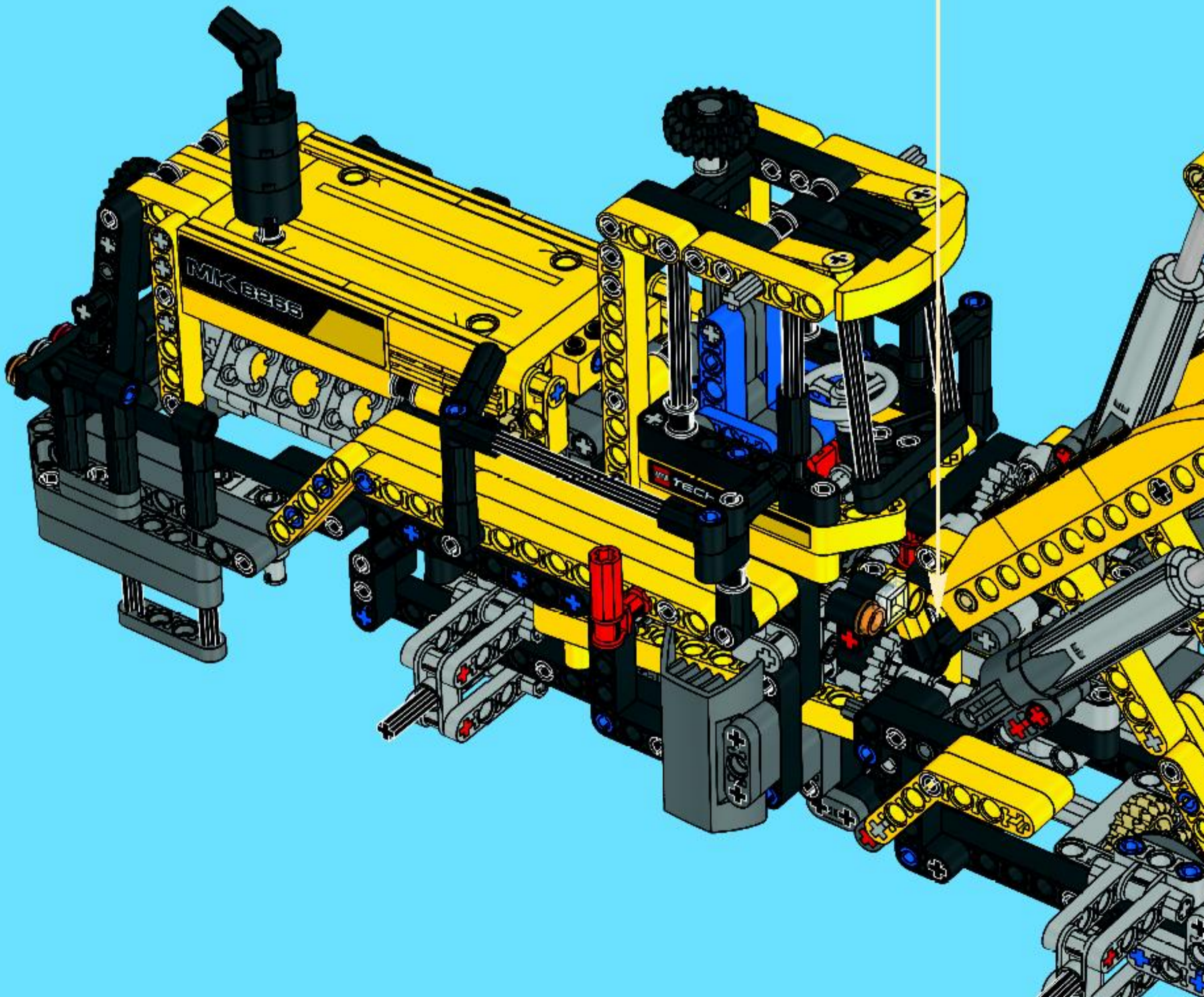
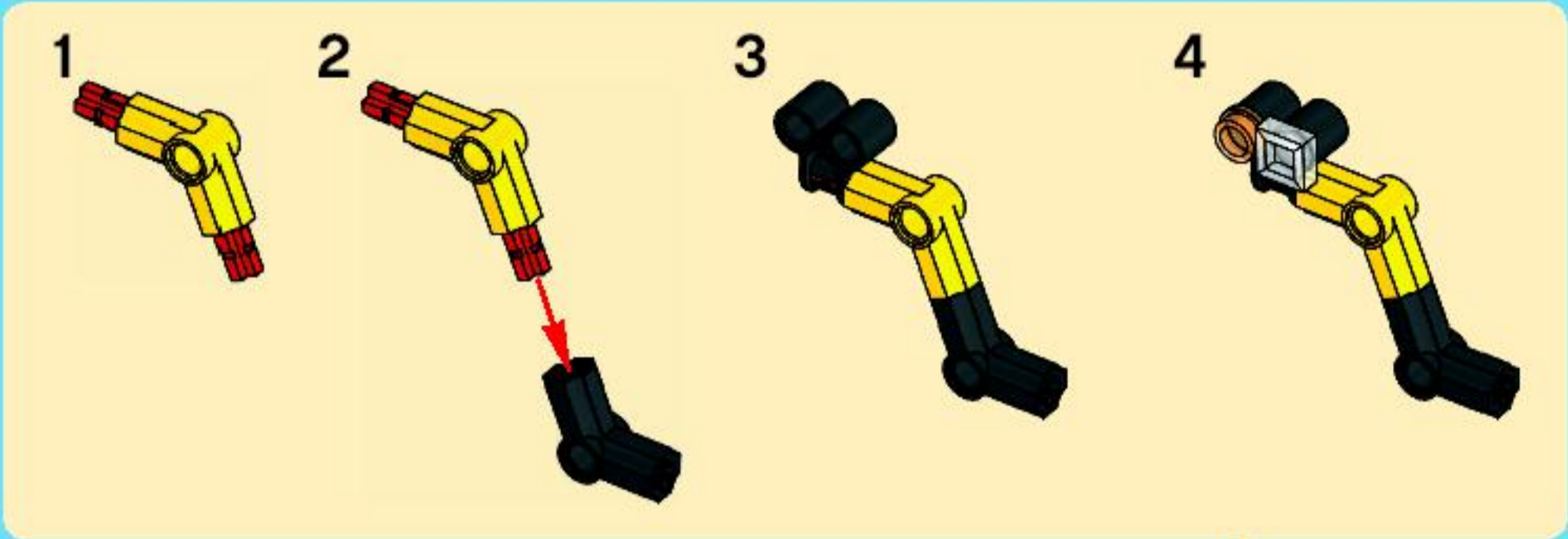



120

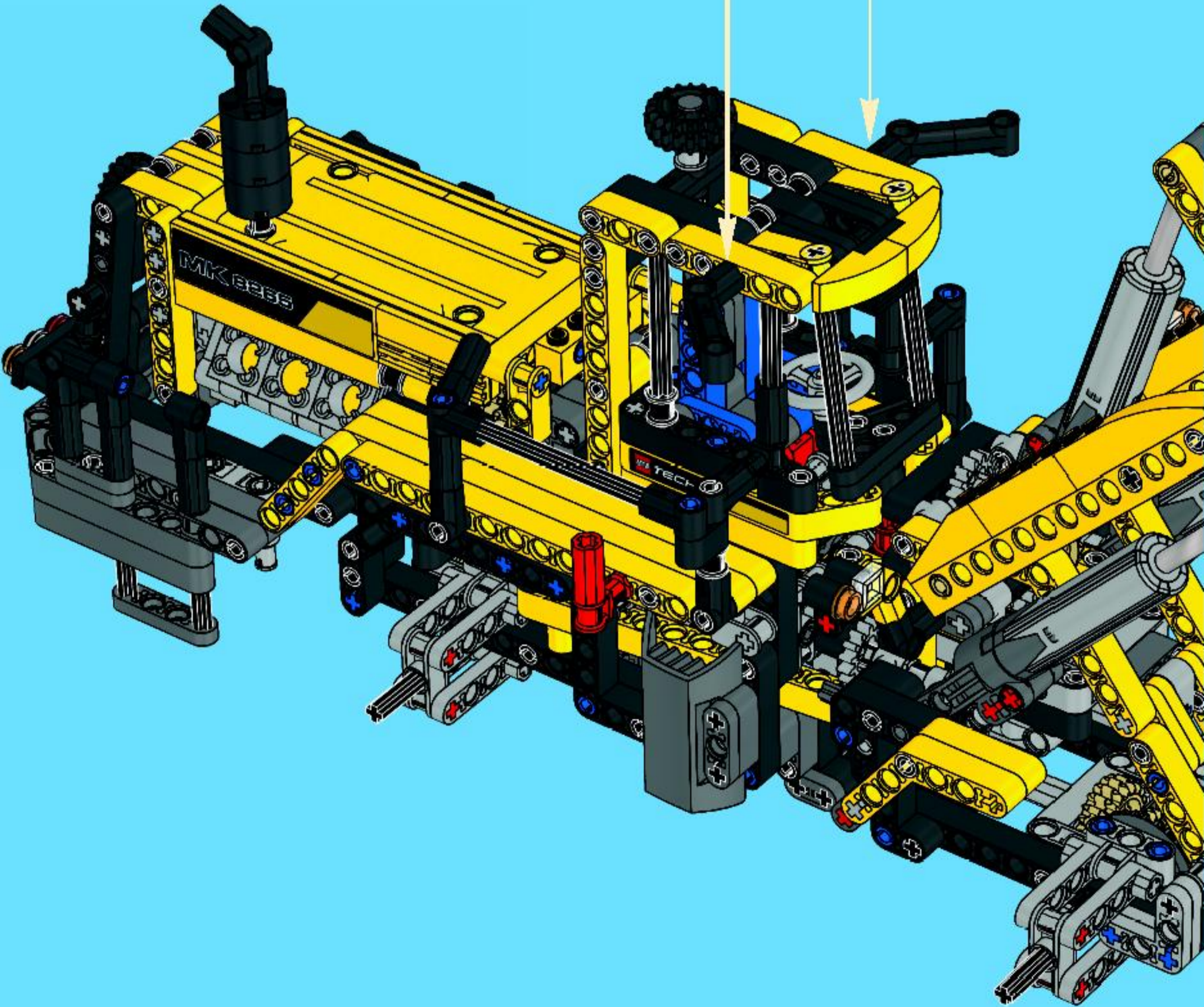
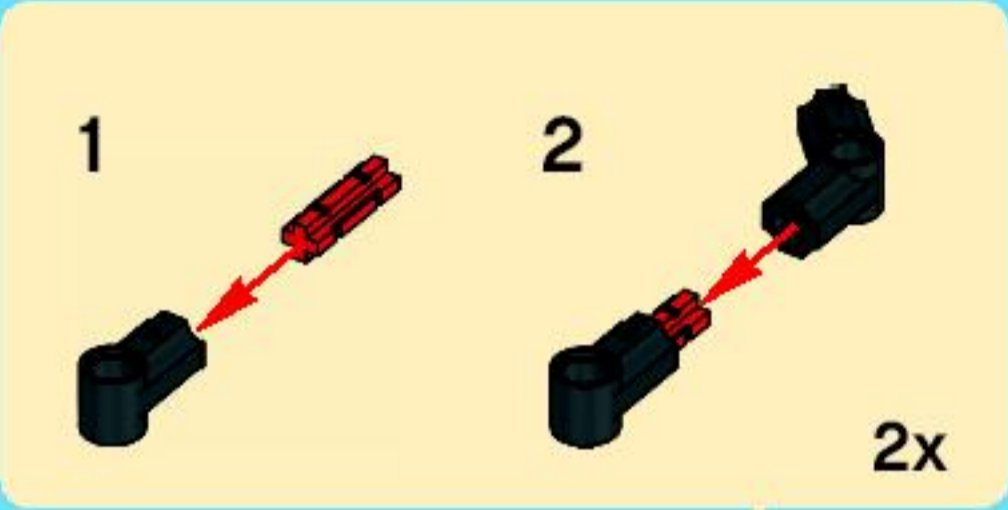



121

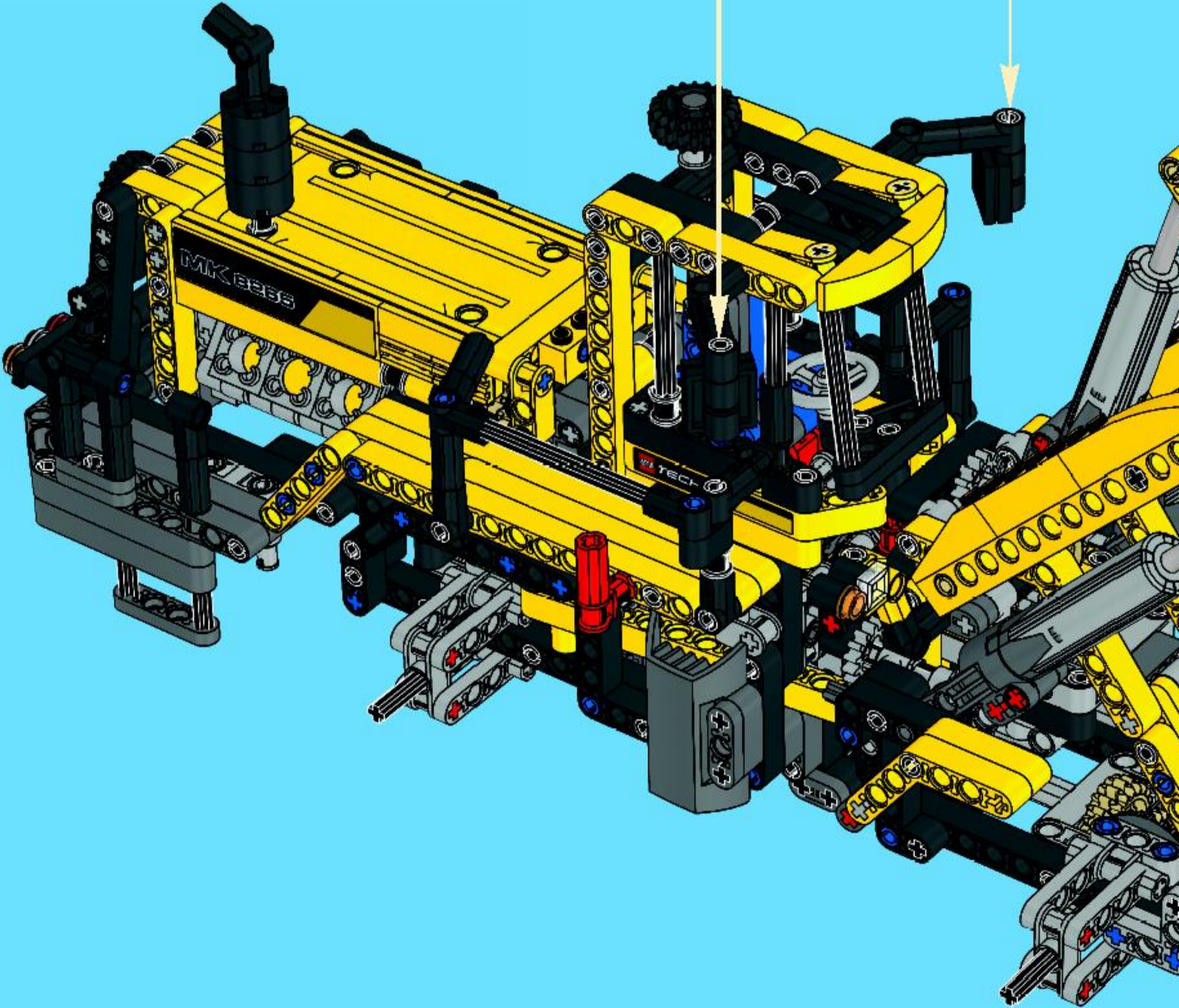
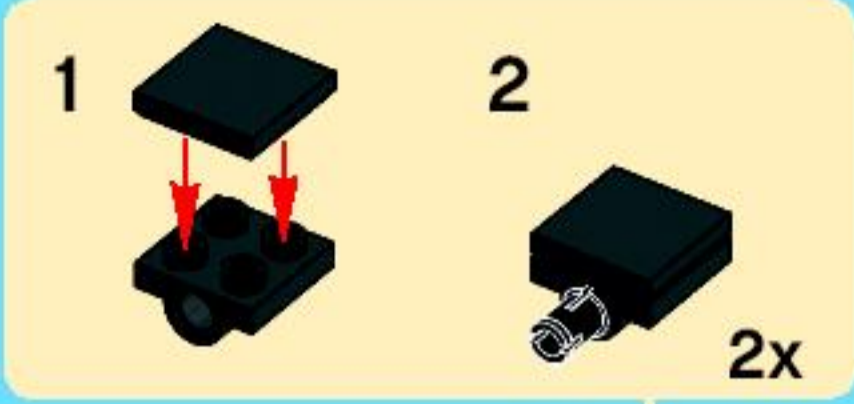



4x



4x

122

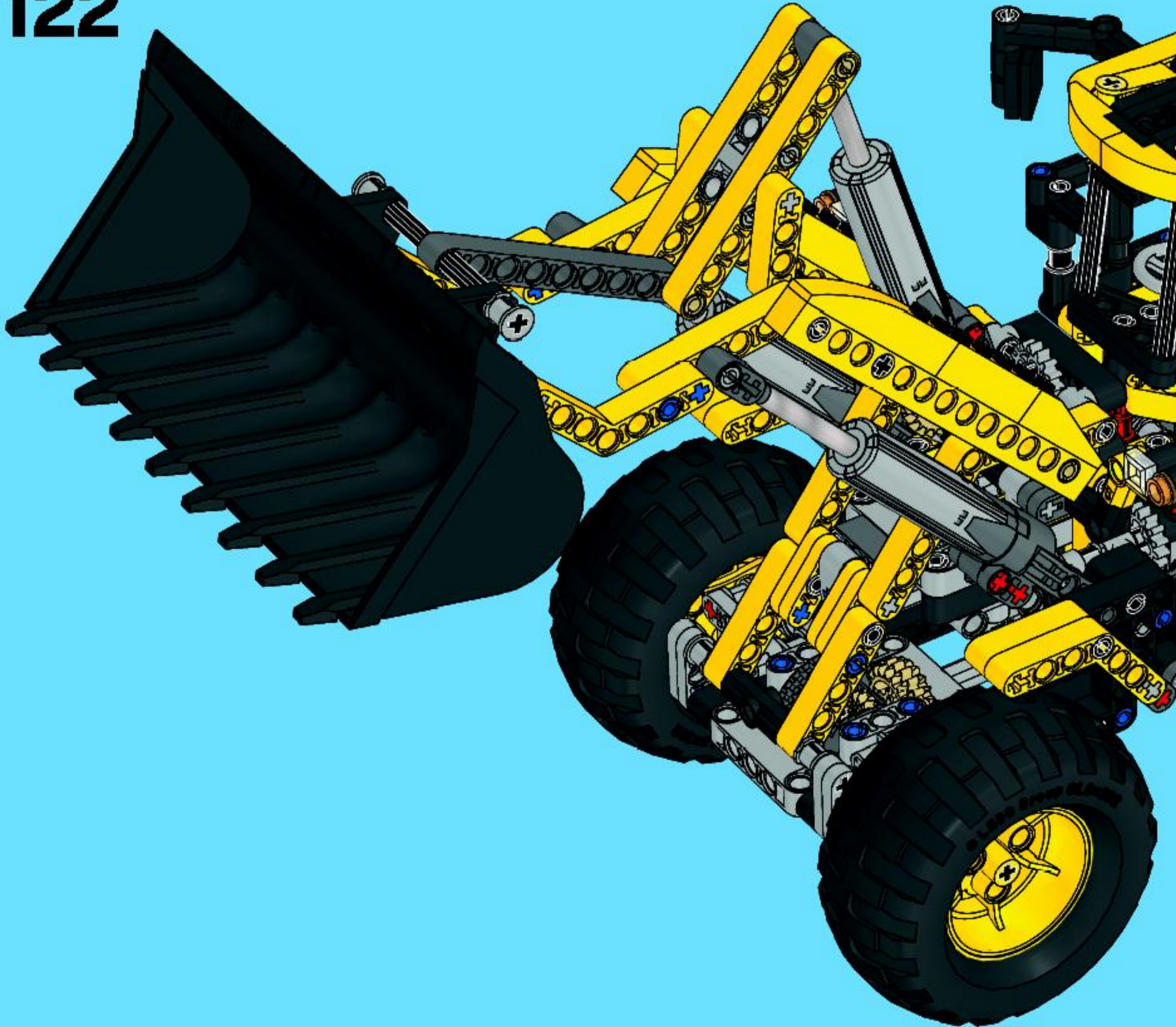

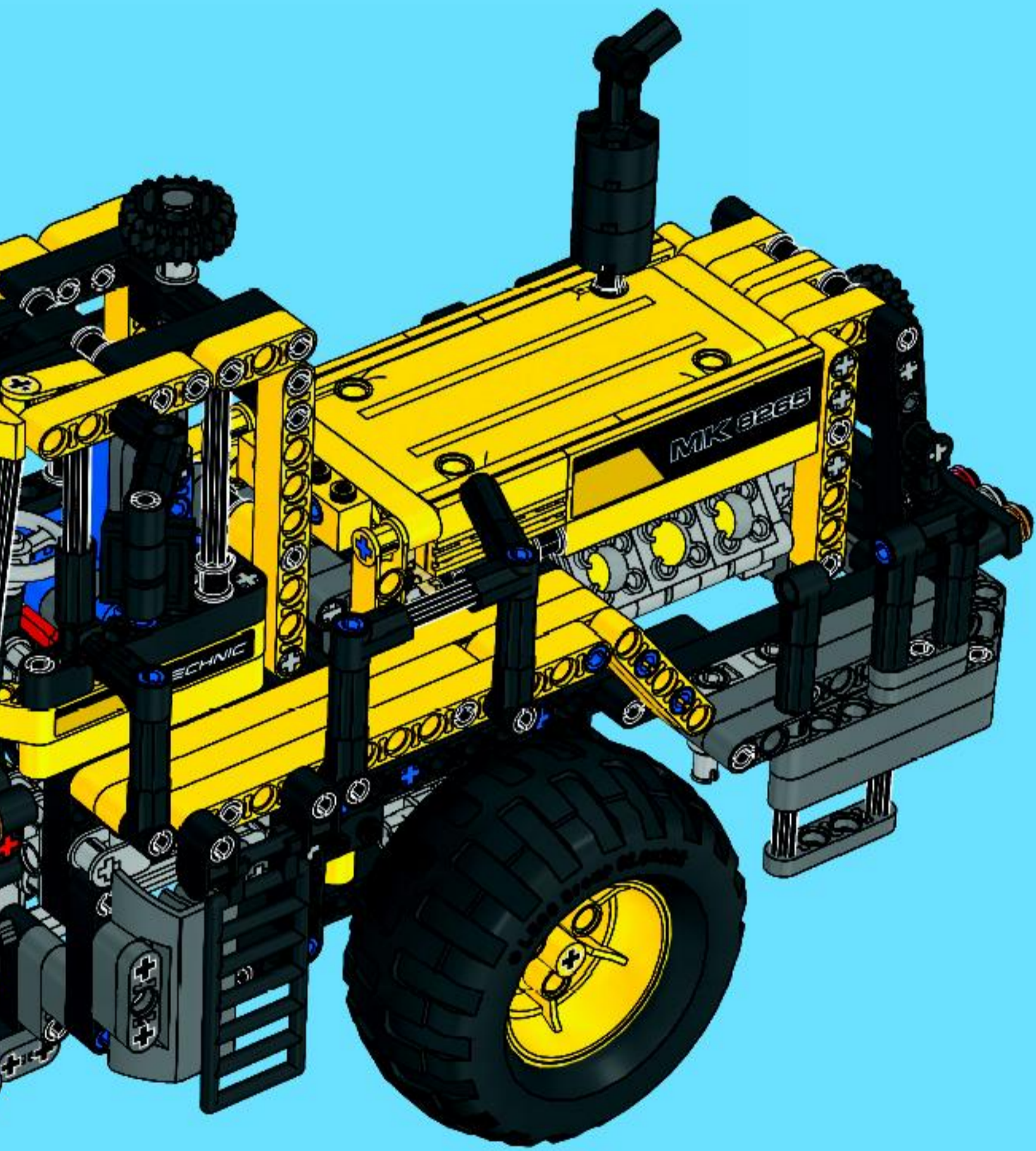



8265

+



8293

=



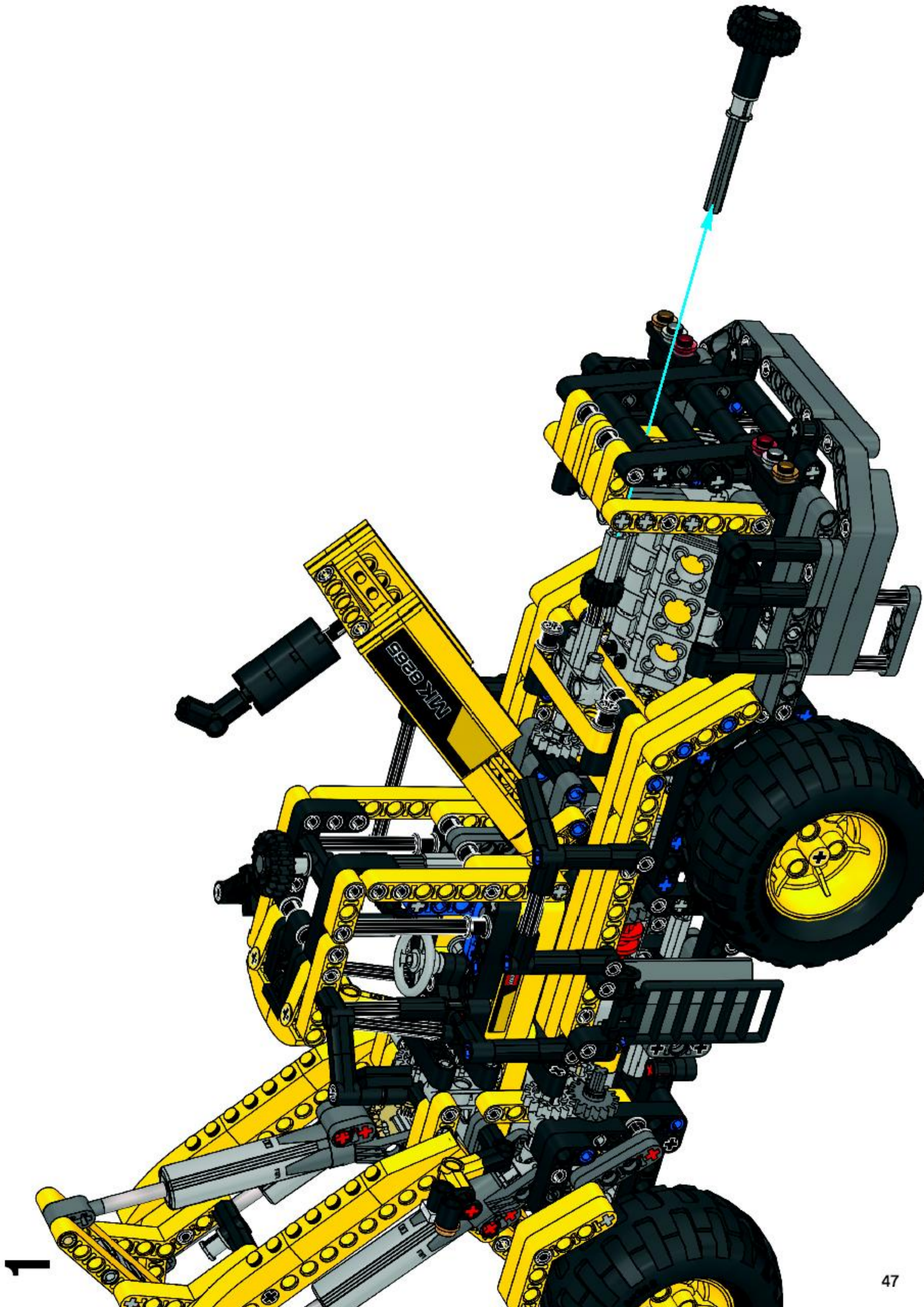





3





5

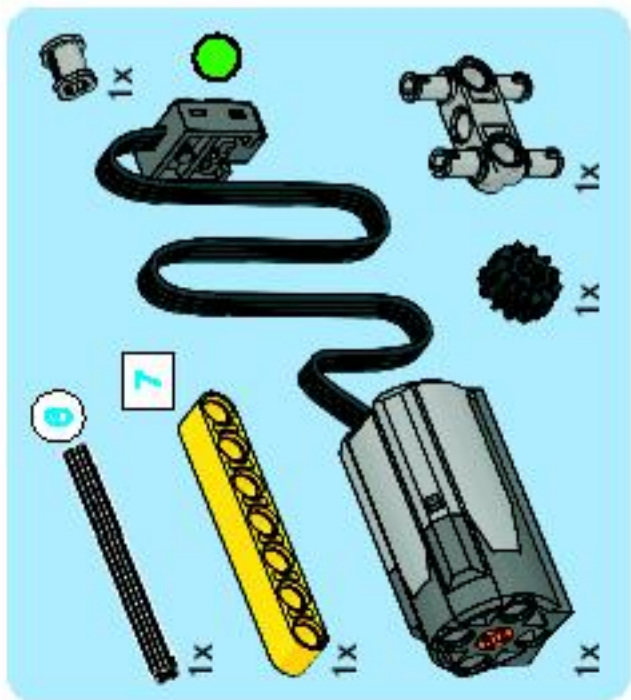

6

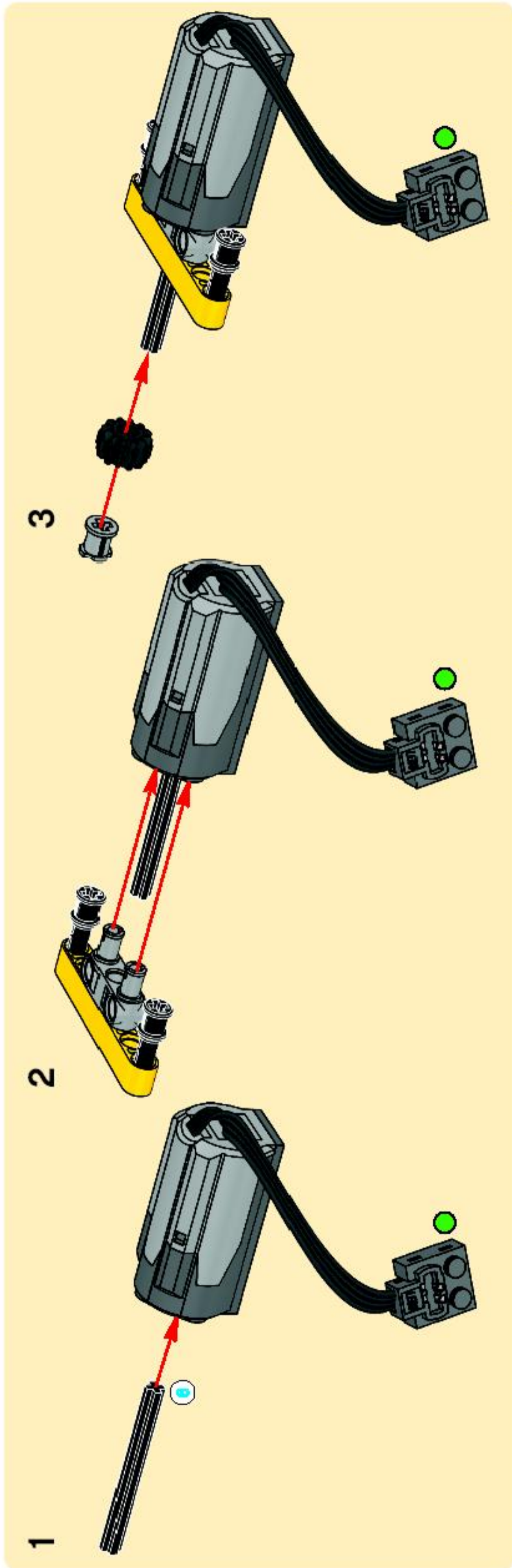



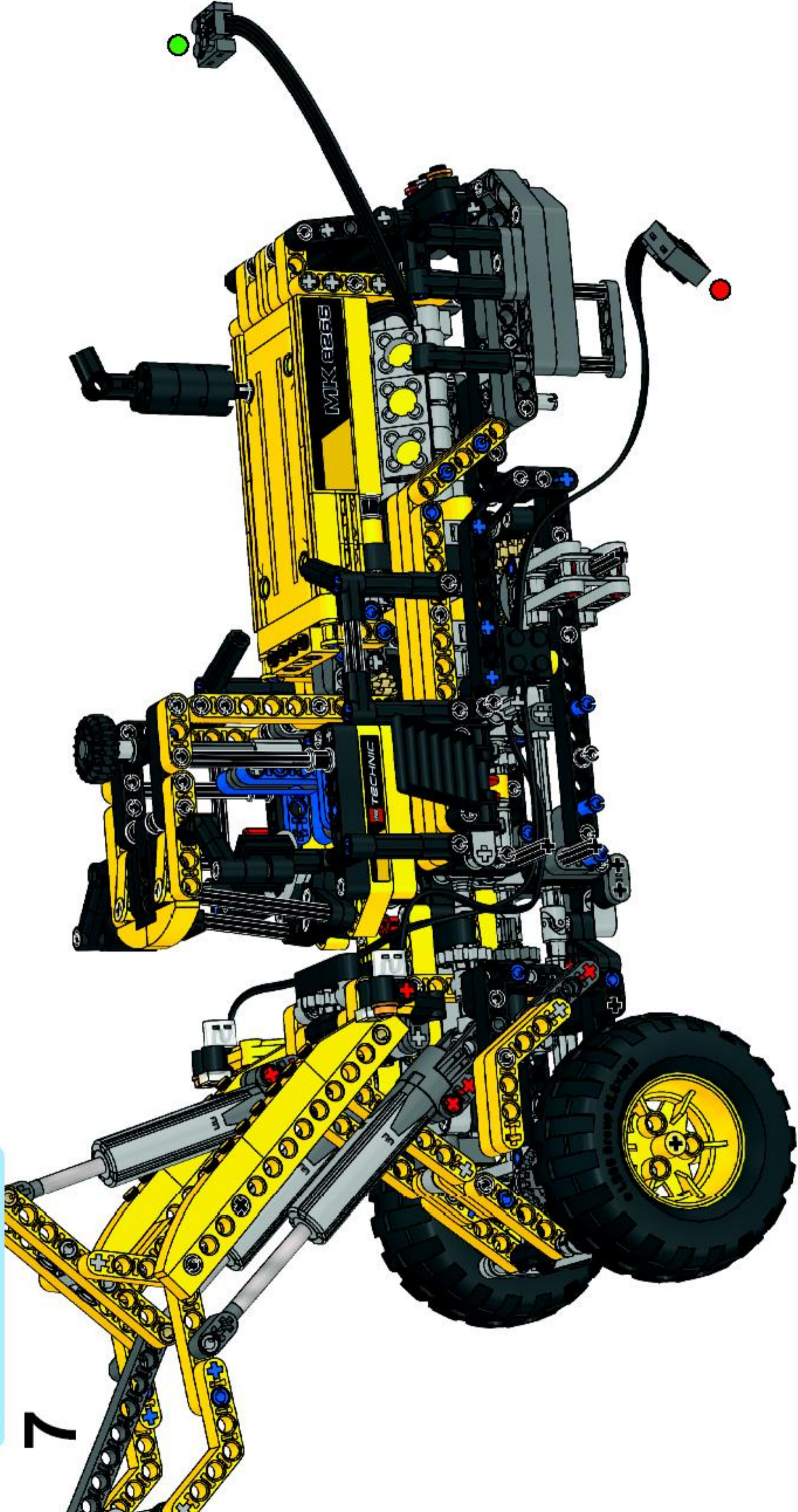

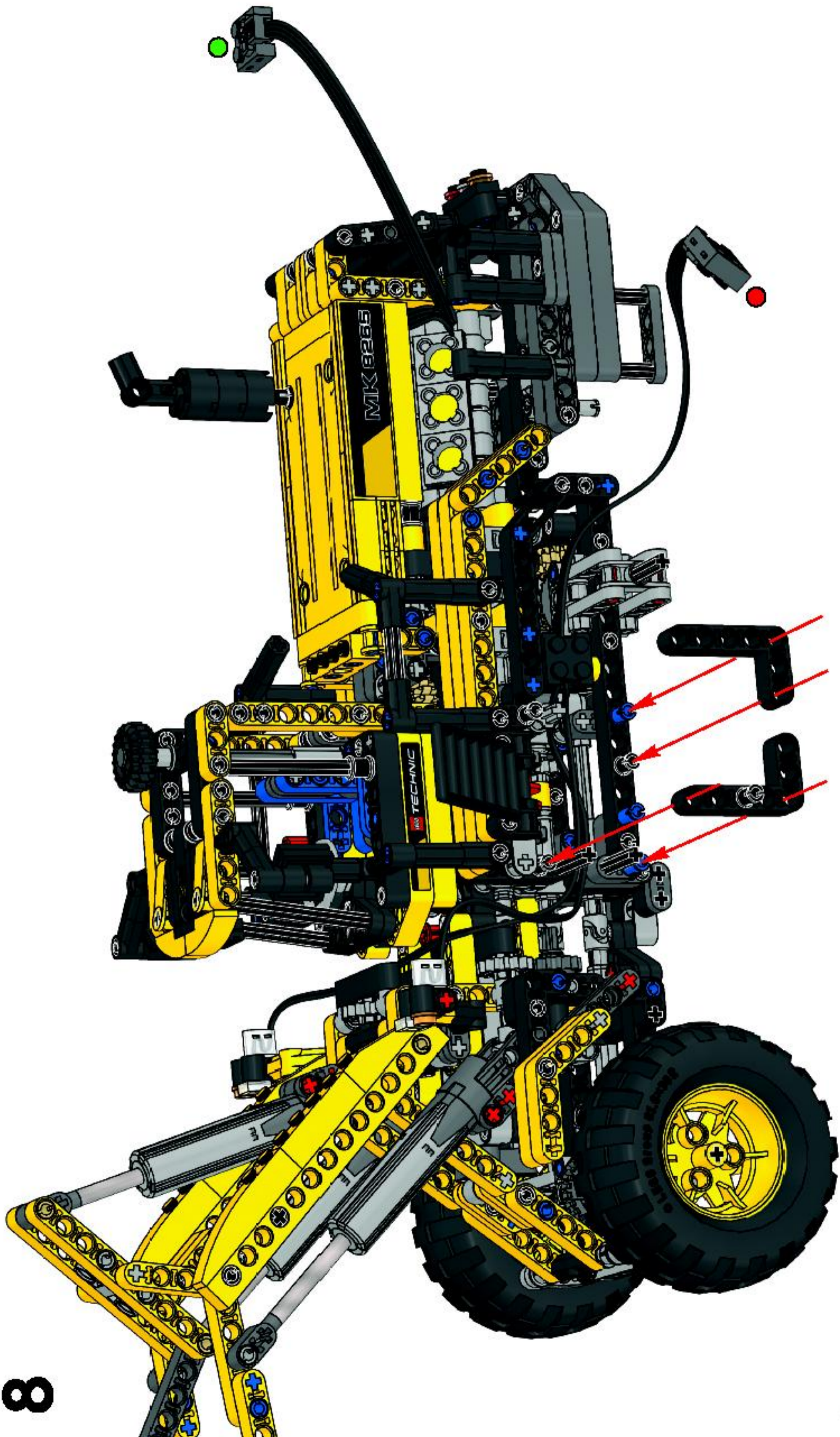

8

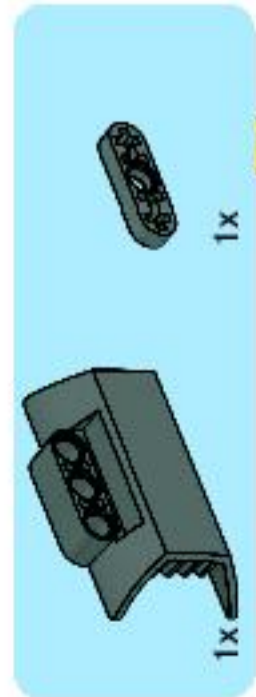

9

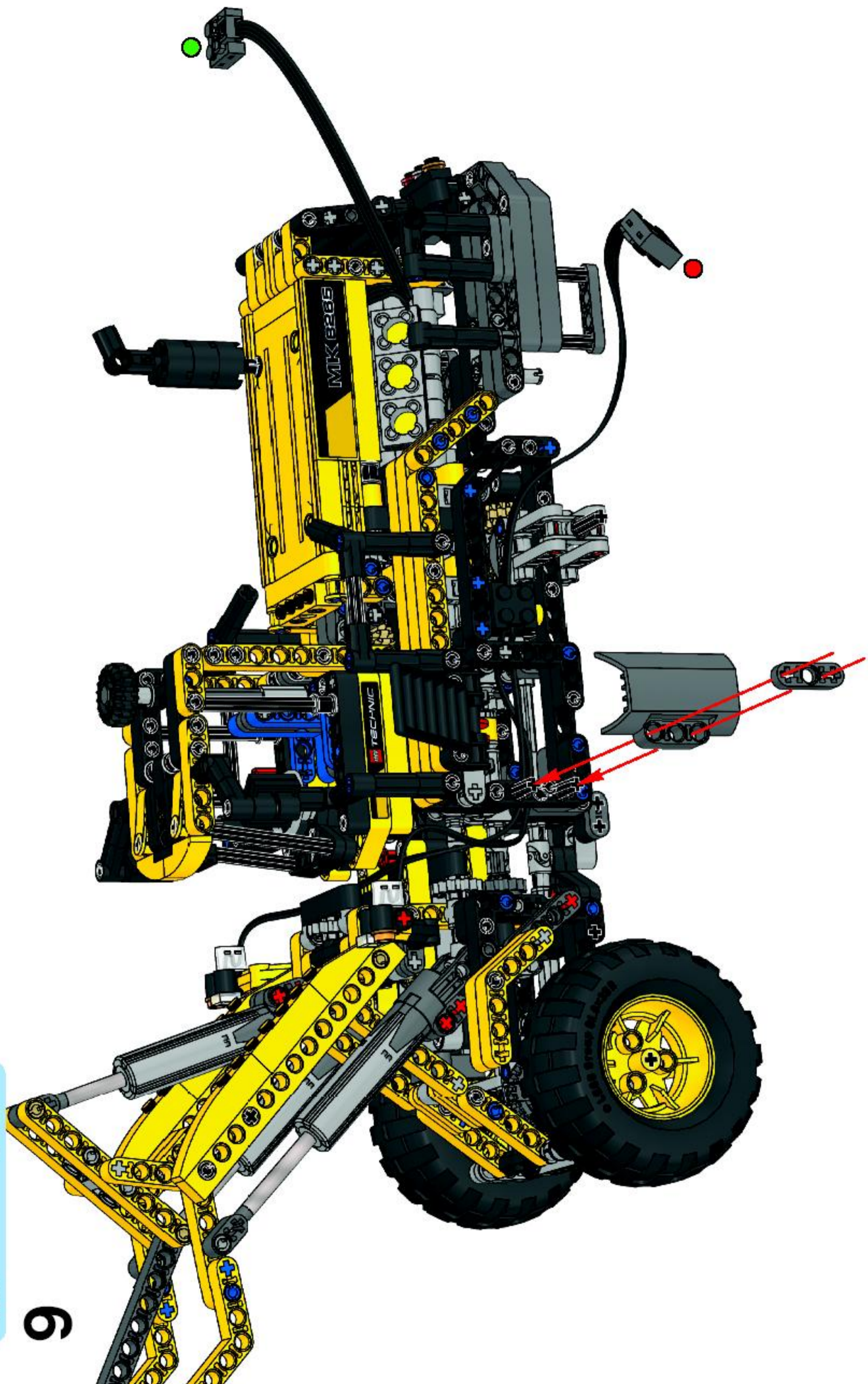



10

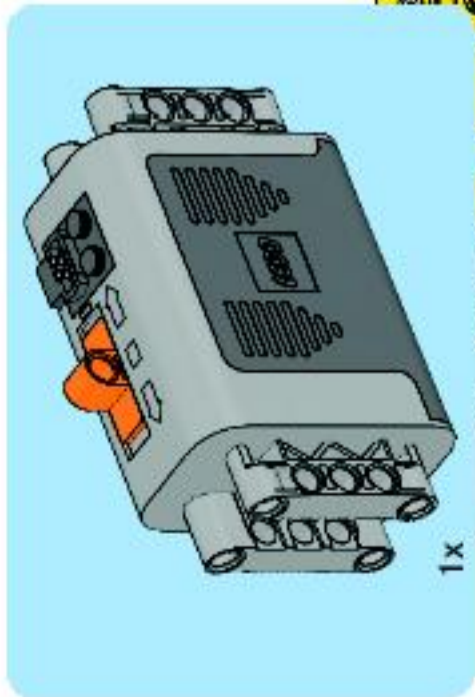
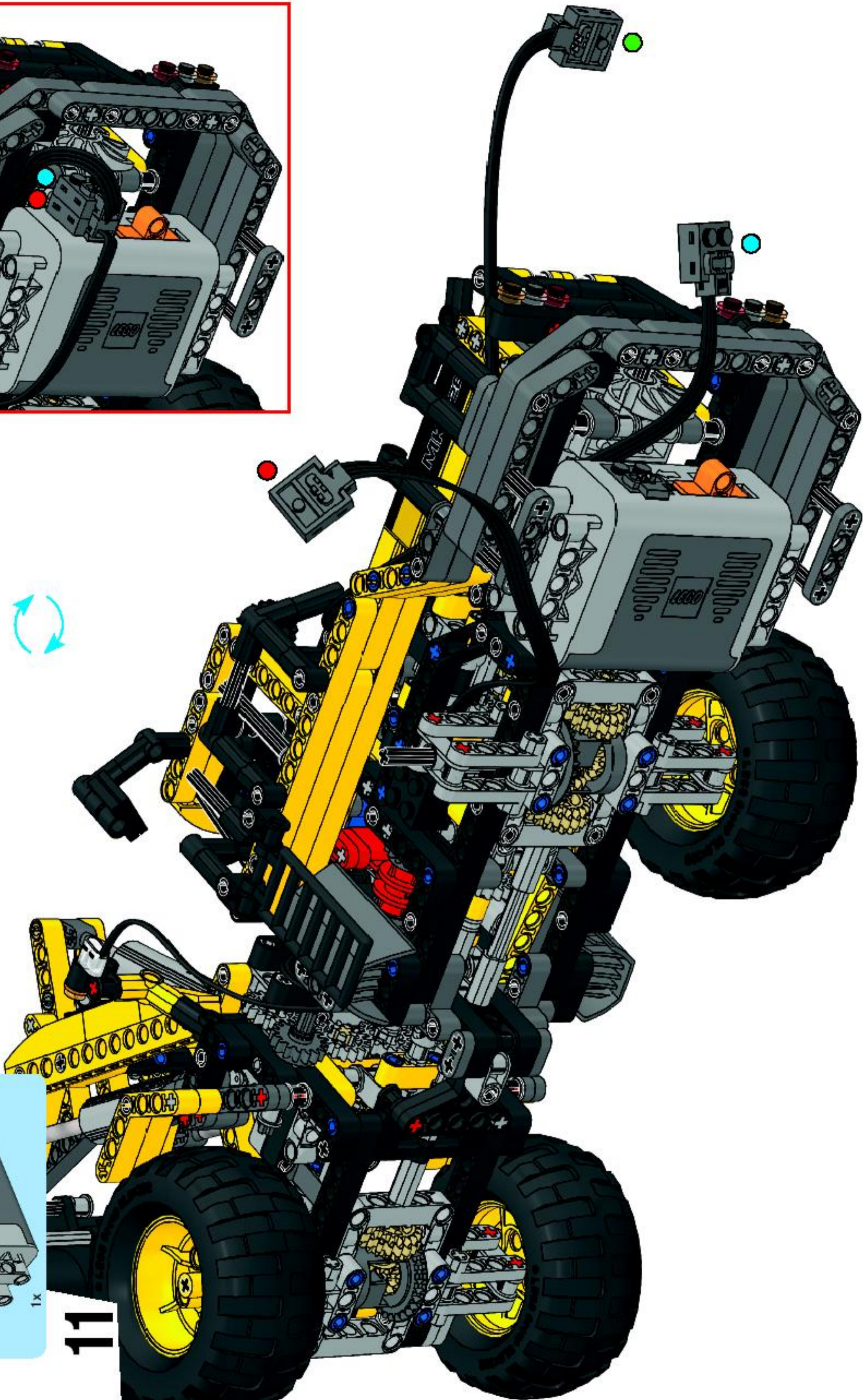
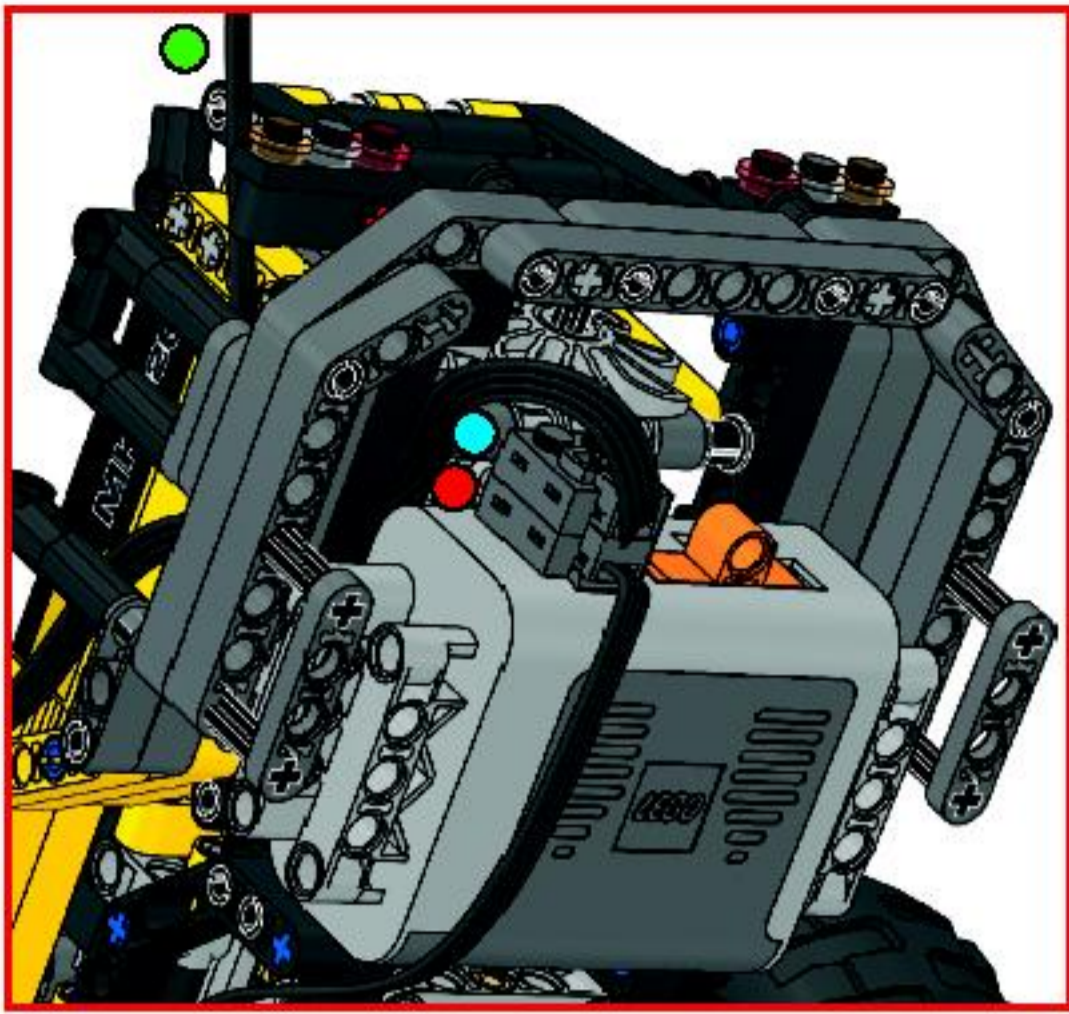



- 47x 4142865
- 2x 4140806
- 1x 4118897
- 3x 4513174
- 1x 4278957
- 1x 4270473
- 4x 4186678
- 28x 4140801
- 139x 4121715
- 2x 4121610
- 19x 4107085
- 5x 4107084
- 7x 4107783
- 2x 4107767
- 4x 4515185
- 3x 614326
- 4x 4107081
- 14x 4512363
- 2x 4173668
- 9x 4173970
- 3x 4140430

- 2x 370826 12
- 1x 373726 10
- 5x 370726 8
- 8x 370626 6
- 29x 370526 4
- 1x 602026
- 3x 281726
- 8x 4107828
- 4x 4177431
- 2x 4177430
- 2x 306826
- 1x 4140303
- 2x 362326
- 1x 302226
- 1x 241226
- 1x 4538722
- 10x 4526982
- 4x 4142543

- 10x 4142135 5
- 2x 4495935 7
- 3x 4154767 8
- 4x 4156150 11
- 2x 4542573 15
- 11x 4142823
- 13x 4120017
- 2x 4111998
- 4x 4198613
- 1x 4537990
- 1x 4211578
- 4x 4211574
- 16x 4211561
- 1x 4159341

- 6x 4211573
- 4x 4296059
- 3x 4539880
- 29x 4211622
- 3x 4211807 8
- 6x 4535768 7
- 10x 4211805 5
- 17x 4211639 3
- 38x 4211815
- 1x 4211510
- 15x 4512360
- 8x 4538007
- 17x 4211775
- 12x 4225033
- 17x 4211621
- 2x 4211609
- 6x 4234251
- 6x 4211379
- 5x 4525904
- 2x 4205761
- 15x 4562487

- 2x 4542579 15
- 3x 4522935 13
- 2x 4174709 11
- 4x 4187136 9
- 17x 4495934 7
- 10x 4142133 5
- 12x 4153707
- 2x 4187122
- 2x 4544005
- 6x 4188311
- 8x 4500485
- 6x 4107823
- 2x 4503425
- 2x 301024
- 1x 370124
- 2x 4544376
- 1x 4539112
- 4x 4543714

- 2x 4521998
- 2x 4515361
- 2x 4160392
- 2x 4247771
- 2x 243124
- 6x 4189400
- 4x 241224
- 4x 346024
- 4x 379524
- 2x 303424
- 4x 4175441
- 6x 4112203
- 53x 4206482
- 46x 4514553
- 16x 4143005
- 2x 4158923
- 2x 4240084
- 3x 4528037

- 2x 4499858
- 2x 4210857
- 2x 4518854
- 2x 4562210
- 1x 4514559
- 6x 4237267
- 1x 4514558
- 8x 4210749
- 2x 4210987
- 8x 4552349
- 3x 4210686 5
- 4x 4210757 9
- 2x 4281516
- 2x 4210668

- 10x 4211050
- 9x 4515183
- 3x 4528038
- 5x 4508553
- 6x 4210980
- 14x 4223767
- 7x 4514555
- 4x 4514554
- 2x 4514557
- 8x 4565452
- 7x 4186017
- 1x 4207456
- 2x 3000840
- 2x 3005740
- 4x 4222960
- 2x 3005741

Customer Service
Kundenservice
 Service Consommateurs
 Servicio Al Consumidor
www.lego.com/service or dial
 : 00800 5346 5555
 : 1-800-422-5346

FREE! GRATIS! GRATUIT!



club
MAGAZINE™

www.LEGOclub.com



00800 5346 5555*



1-866-534-6258 • 1-877-518-5346

US & Canada only

Canada seulement

* FreePhone. Minicall charges may apply. ** Numéro sans Frais. Des Frais peuvent s'appliquer avec les téléphones cellulaires. *** Gebührenfrei, nur bei Fix- und Festnetzen. **** Kostenlos, nur bei Festnetz. ***** Gratís, sólo en líneas fijas. ** Det er et gratis nummer, når du ringer fra Posttelefon. *** Det är gratis, när du ringer från Posttelefon.



**VISIT THE WORLD'S
BIGGEST LEGO® SHOP!**

www.LEGOshop.com

WIN LEGO® PRODUCTS

Fill out a survey and you might WIN a cool LEGO product!

NO PURCHASE NECESSARY

Open to all residents where not prohibited

Go to www.acnielsen.aim.dk/LEGO to fill out a survey for a chance to win a LEGO product.

WIN LEGO® PRODUCTEN

Vul een enquêteformulier in en maak kans op een cool LEGO® product!

Kopen niet nodig

Iedereen uit landen waar geen enquêteverbod geldt mag deelnemen.

Ga naar www.acnielsen.aim.dk/LEGO, vul een enquêteformulier in en maak kans op een LEGO product.

GEWINNE LEGO® PRODUKTE

Nimm an der Umfrage teil und GEWINNE ein tolles LEGO® Produkt!

Die Teilnahme am Gewinnspiel führt zu keinerlei

Kaufverpflichtungen

Teilnahme in allen nicht ausgeschlossenen Ländern möglich

Wir verlosen unter allen Teilnehmern der Umfrage auf

www.acnielsen.aim.dk/LEGO LEGO Produkte.

GAGNE DES PRODUITS LEGO®

Réponds à un questionnaire et tu pourras GAGNER un produit LEGO® très cool !

Aucune obligation d'achat.

Ouvert à tous les résidents des pays autorisés.

Visite www.acnielsen.aim.dk/LEGO pour répondre à un questionnaire et avoir une chance de gagner un produit LEGO.

レゴ®製品を「当てよう」

アンケートに記入して、かっこいいレゴ®製品を当てよう！

お買い上げの必要はありません。

禁止されていない限り、すべての皆様にご利用いただけます。

www.acnielsen.aim.dk/LEGOにアクセスして、アンケートにご記入ください。当選者にはレゴ製品を差し上げます。

www.nielsen.com/LEGO



 www.LEGO.com

©2009 The LEGO Group. 456891